

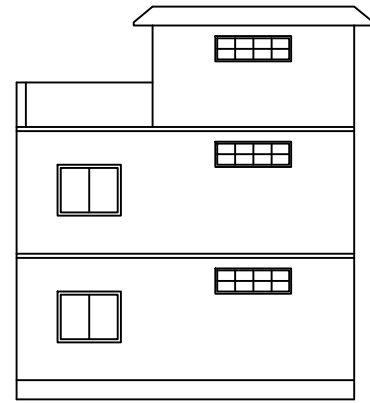

FRONT ELEVATION

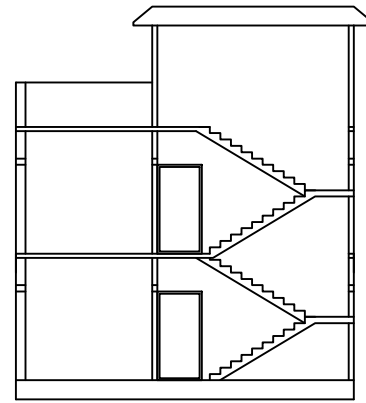

LEFT SIDE ELEVATION



SECTION Y - Y

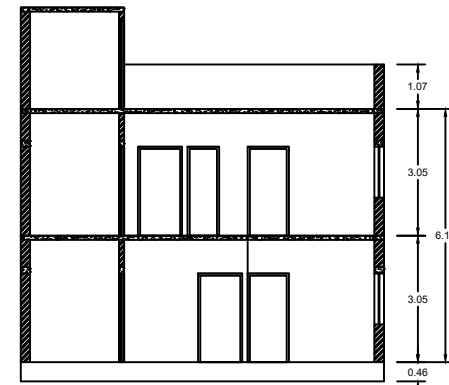

SECTION X - X

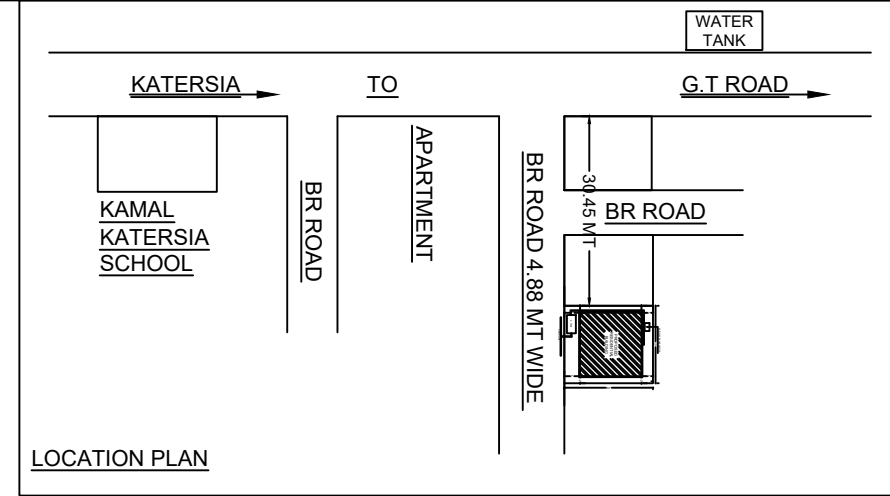

LOCATION PLAN

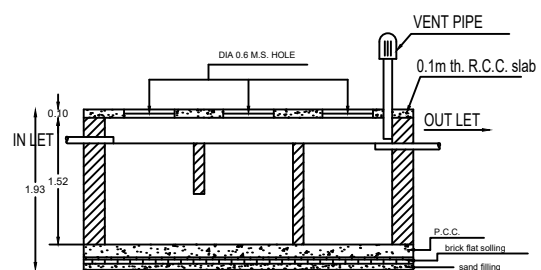

SECTION

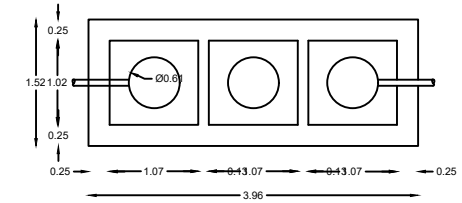

DETAILS OF SEPTIC TANK

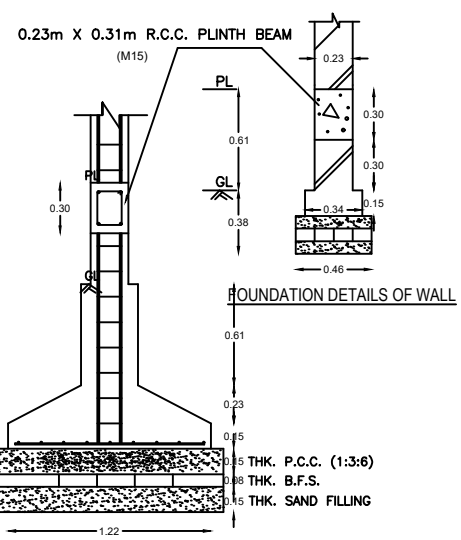

FOUNDATION DETAILS OF WALL

FOUNDATION DETAILS OF COLUMN

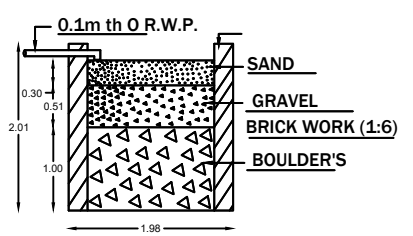

SECTION ON - AA

DETAIL'S OF WATER HARVESTING

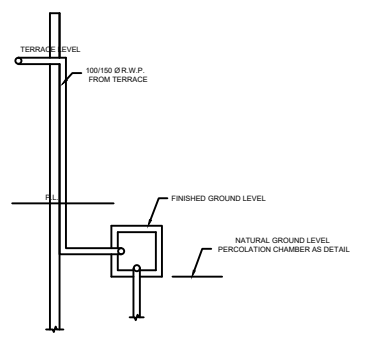

ROOF TOP RAIN WATER COLLECTION SYSTEM
SCALE - 1" = 4'-0"

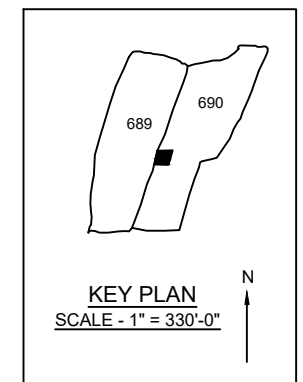
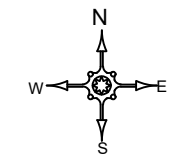

KEY PLAN
SCALE - 1" = 330'-0"

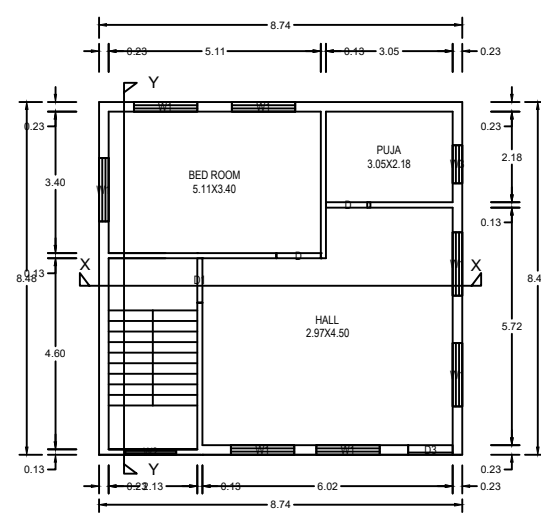

GROUND FLOOR PLAN
SCALE - 1" = 8'-0"

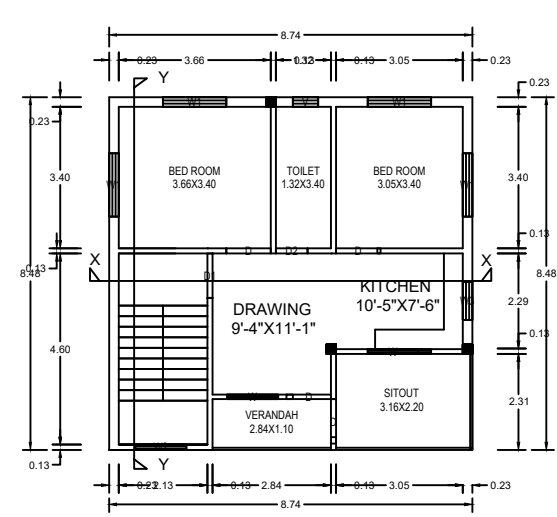

FIRST FLOOR PLAN
SCALE - 1" = 8'-0"

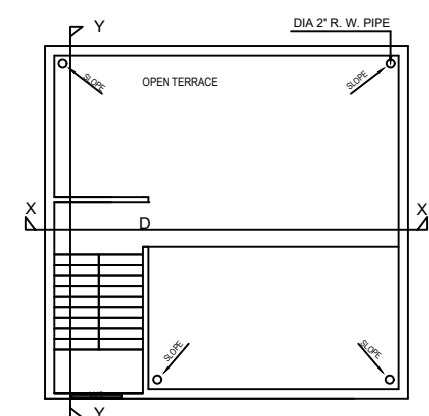

TERRACE FLOOR PLAN
SCALE - 1" = 8'-0"

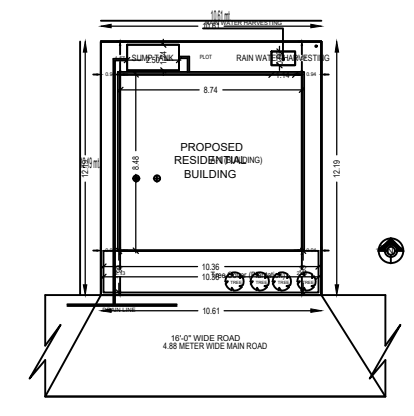

SITE PLAN
SCALE - 1" = 16'-0"

BRIEF SPECIFICATION

FOUNDATION	: 6" th. P.C.C. (1:1:3) foundation bed & first class brick work in cement mortar (1:6) in foundation.
PLINTH	: 1 1/2" th. D.P.C. (1:1:3) all round on the plinth level.
FLOORING	: 1 1/2" th. I.P.S./ Marble flooring over 3" th. P.C.C. (1:3:6).
SUPERSTRUCTURE	: First class brick work in cement mortar (1:6).
SLAB, BEAM & LINTEL	: All R.C.C. works (1:1 1/2:3).
WOOD WORKS	: All doors & windows frames of sal wood.
PLASTERING	: 3/4" th. cement plaster (1:6) in both side.
STAIR CASE	: RISE - 6", TREAD - 10"

SCHEDULE

D	- 3'-6" X 7'-0"	W	- 5'-0" X 4'-0"
D1	- 3'-0" X 7'-0"	W1	- 4'-0" X 4'-0"
D2	- 2'-6" X 7'-0"	W2	- 3'-0" X 4'-0"
		V	- 2'-0" X 2'-0"

DETAILS OF AREA

LAND AREA	: 129.76 Sq.mtr. (AS PER DEED)
LAND AREA	: 129.38 Sq.mtr. (AS PER SITE)
GROUND FLOOR AREA	: 74.13 Sq.mtr.
FIRST FLOOR AREA	: 74.13 Sq.mtr.
COVERED AREA	: 148.26 Sq.mtr.
F.A.R	: 1.15
% OF PLINTH AREA	: 57.30 %

TITLE OF DRAWING

PLAN FOR PROPOSED RESIDENTIAL BUILDING DRAWING OF SRI. BIJAY KUMAR VISHWKARMA S/O LATE BADRI NARAYAN OF BARTAND P. S And Dist. DHANBAD, UNDER MOUZA - BHELATAND, NO. - 89, KHATA NO. - 24, PLOT NO. - 690, DIST. - DHANBAD.

SIG. OF OWNER

SIG. OF ENGINEER