

KEY PLAN

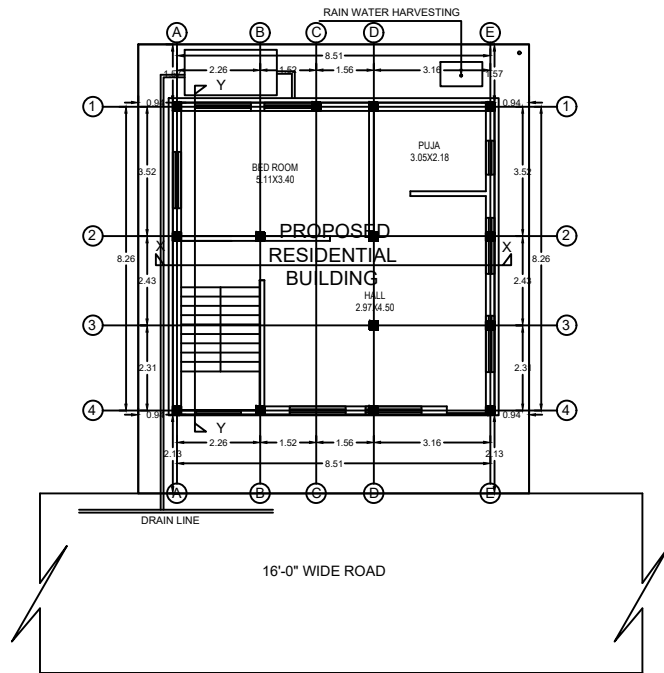

SITE PLAN  
SCALE - 1" = 16'-0"

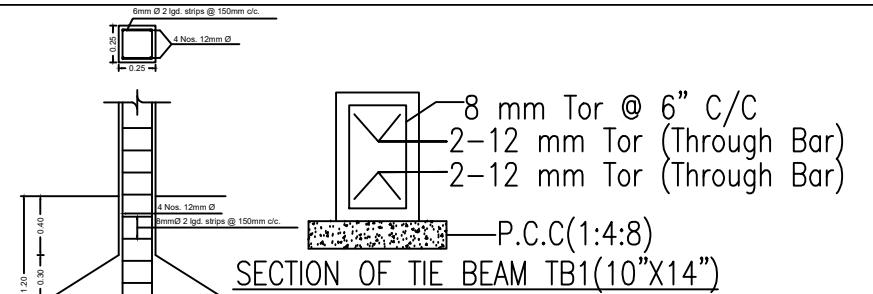

SECTION OF TIE BEAM TB1(10"X14")

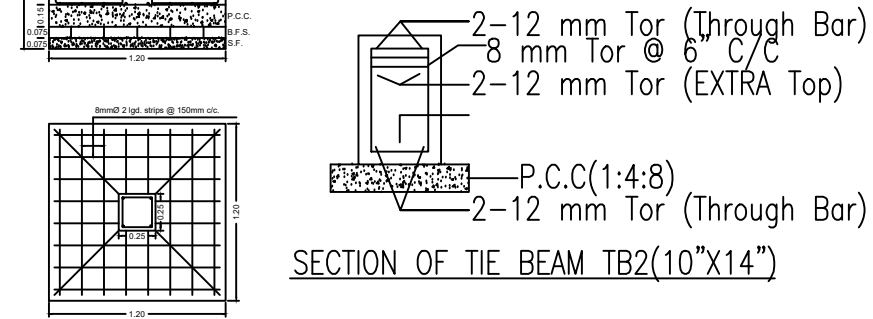

SECTION OF TIE BEAM TB2(10"X14")

DETAILS OF FOUNDATION  
SCALE = 1:25

COLUMN SCHEDULE				
COLUMN SIZE	B	9"	9"	9"
CONCRETE MIX	M20	M20	M20	M20
SECTION WITH MAIN STEEL		4 - 16 mm. Tor	4 - 16 mm. Tor	4 - 16 mm. Tor
		6 - 12 mm. Tor	2 - 12 mm. Tor	6 - 12 mm. Tor
LINKS				
FOUNDATION TO 1ST FLOOR LEVEL				
	8 mm. @ 6" C/C AT SUPPORT & 8 mm. @ 8" C/C AT MIDDLE	8 mm. @ 6" C/C AT SUPPORT & 8 mm. @ 8" C/C AT MIDDLE	8 mm. @ 6" C/C AT SUPPORT & 8 mm. @ 8" C/C AT MIDDLE	8 mm. @ 6" C/C AT SUPPORT & 8 mm. @ 8" C/C AT MIDDLE

DETAILS OF AREA

LAND AREA : 129.76 Sq.mtr. (AS PER DEED)  
 LAND AREA : 129.38 Sq.mtr. (AS PER SITE)  
 GROUND FLOOR AREA : 74.13 Sq.mtr.  
 FIRST FLOOR AREA : 74.13 Sq.mtr.  
 COVERED AREA : 148.26 Sq.mtr.  
 F.A.R : 1.29  
 % OF PLINTH AREA : 64.48 %

SIGNATURE OF OWNER

LAYOUT PLAN OF THE PROPOSED RESIDENTIAL BUILDING  
 OF SRI. BIJAY KUMAR VISHWKARMA S/O LATE BADRI  
 NARAYAN OF BARTAND P. S And Dist. DHANBAD,  
 UNDER MOUZA - BHELATAND, NO. - 89,  
 KHATA NO. - 24, PLOT NO. - 690, DIST. - DHANBAD.

SIGNATURE OF ENGINEER