

Proposal Basic Information

Proposal File No.	DMC/BP/0118/W20/2018
Owner Name	SMT. NEELAM KUMARI
Khata No	04
Plot No	05 OLD 134 NEW
Village Name	Bisanpur
Use	Residential
SubUse	Bungalow/ Dwelling / Non Apartment

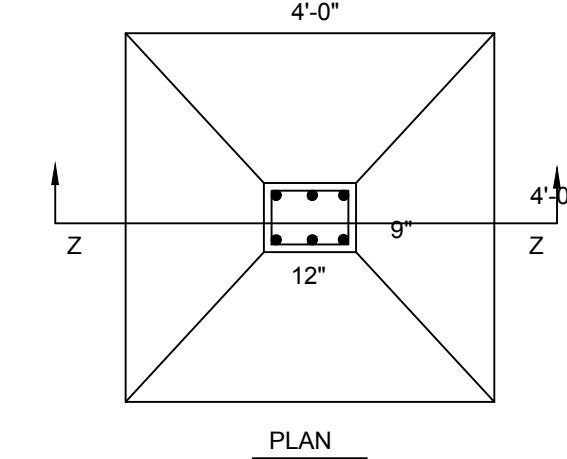

*DETAILS OF COLUMN FOOTING
SCALE :- 1" = 2'-0"

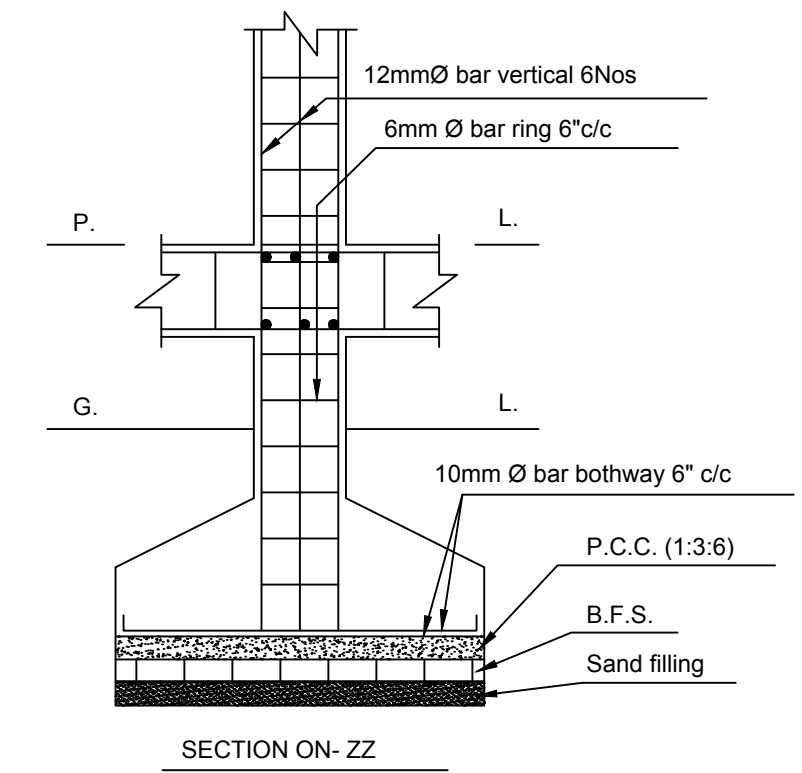
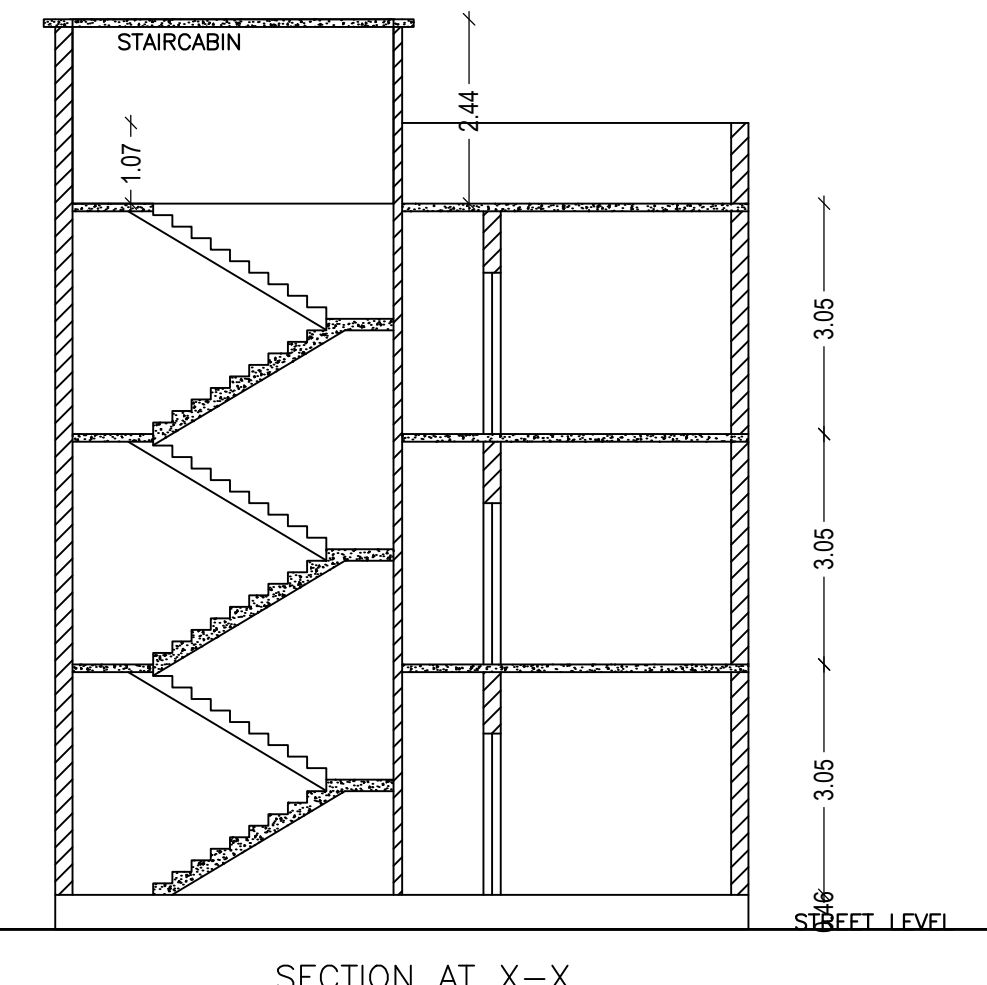
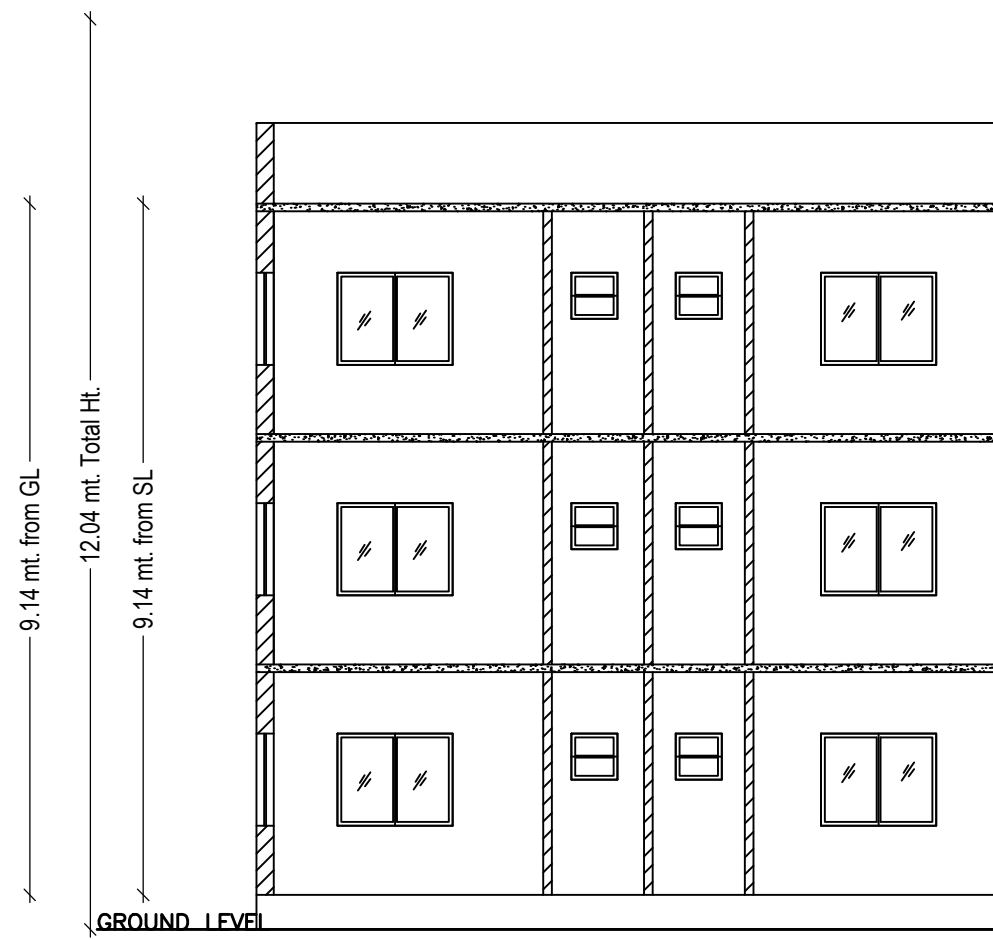
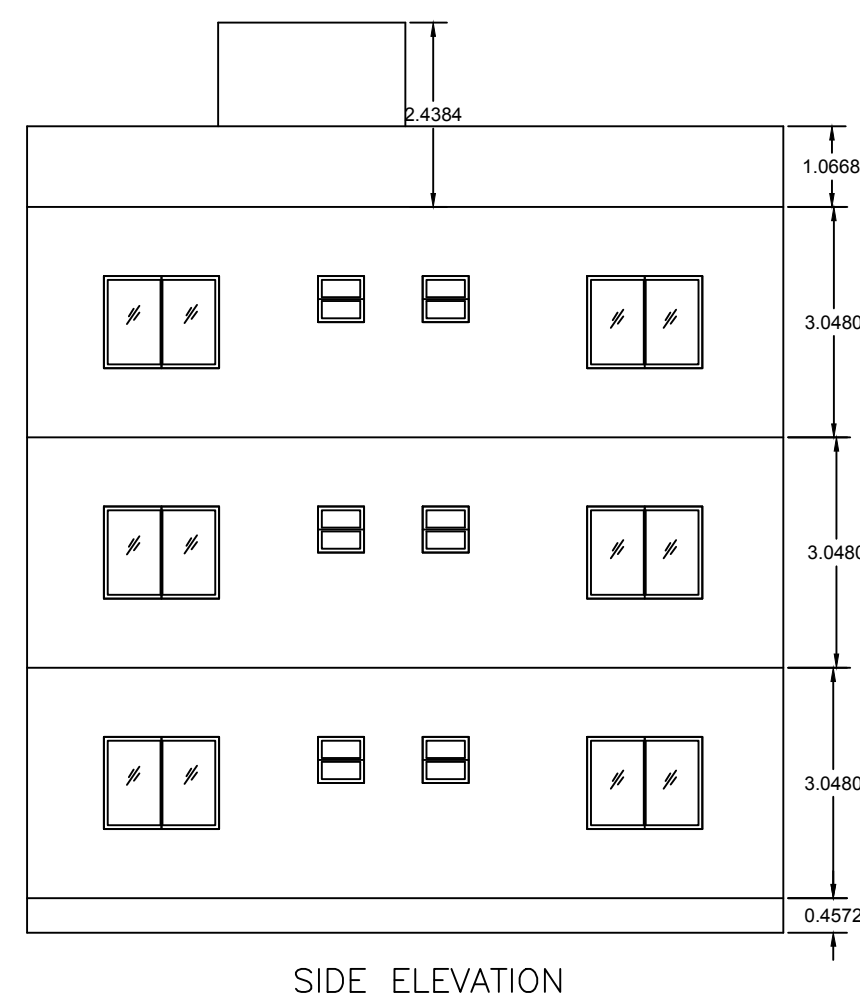
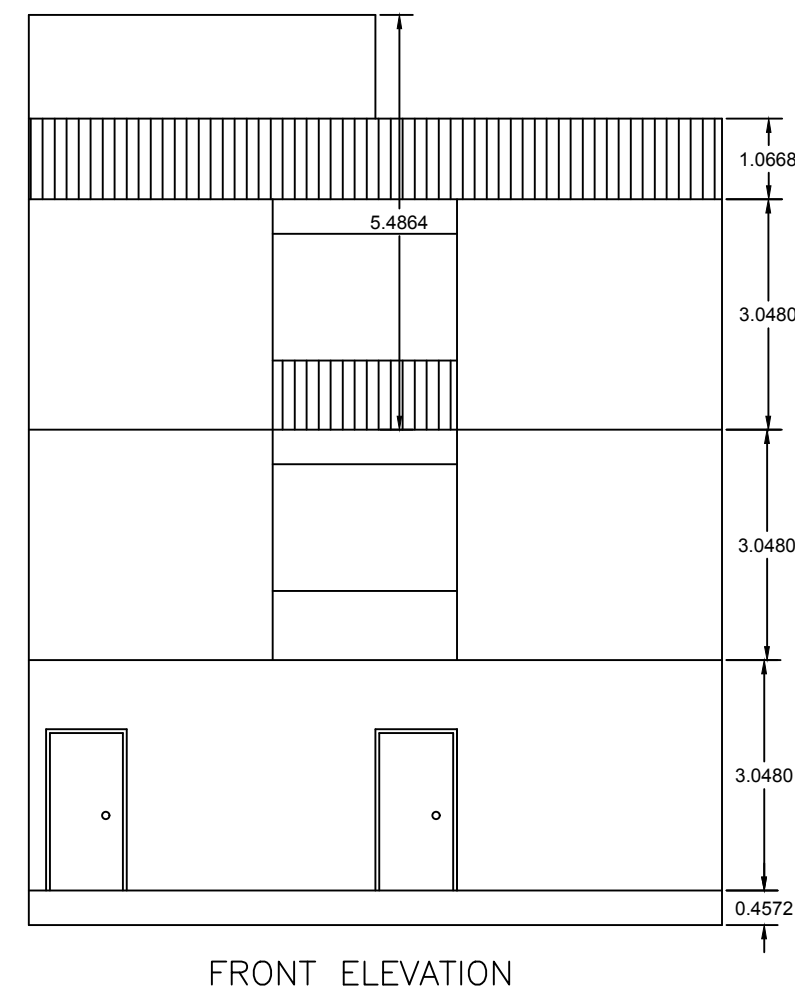
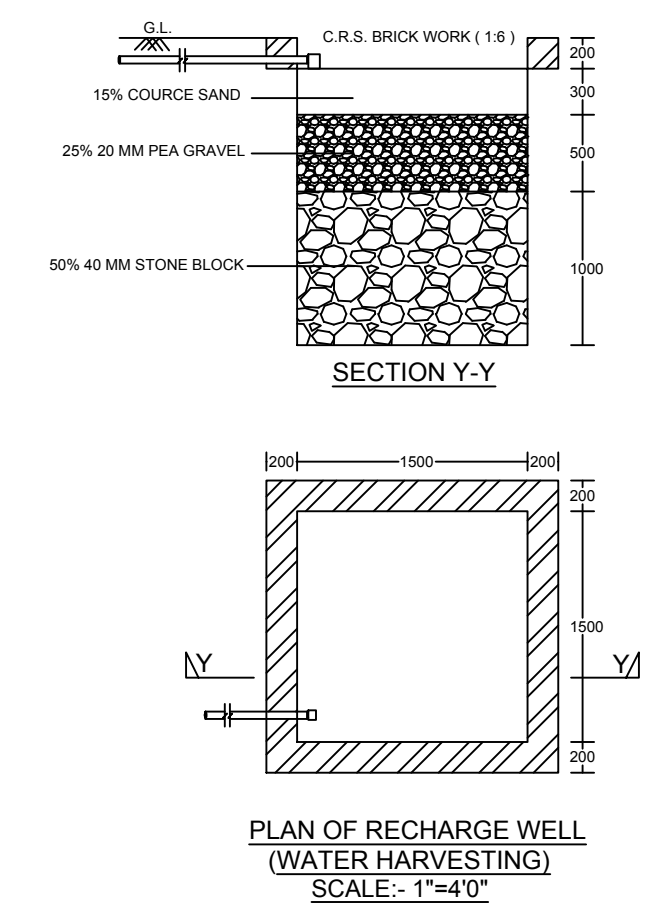
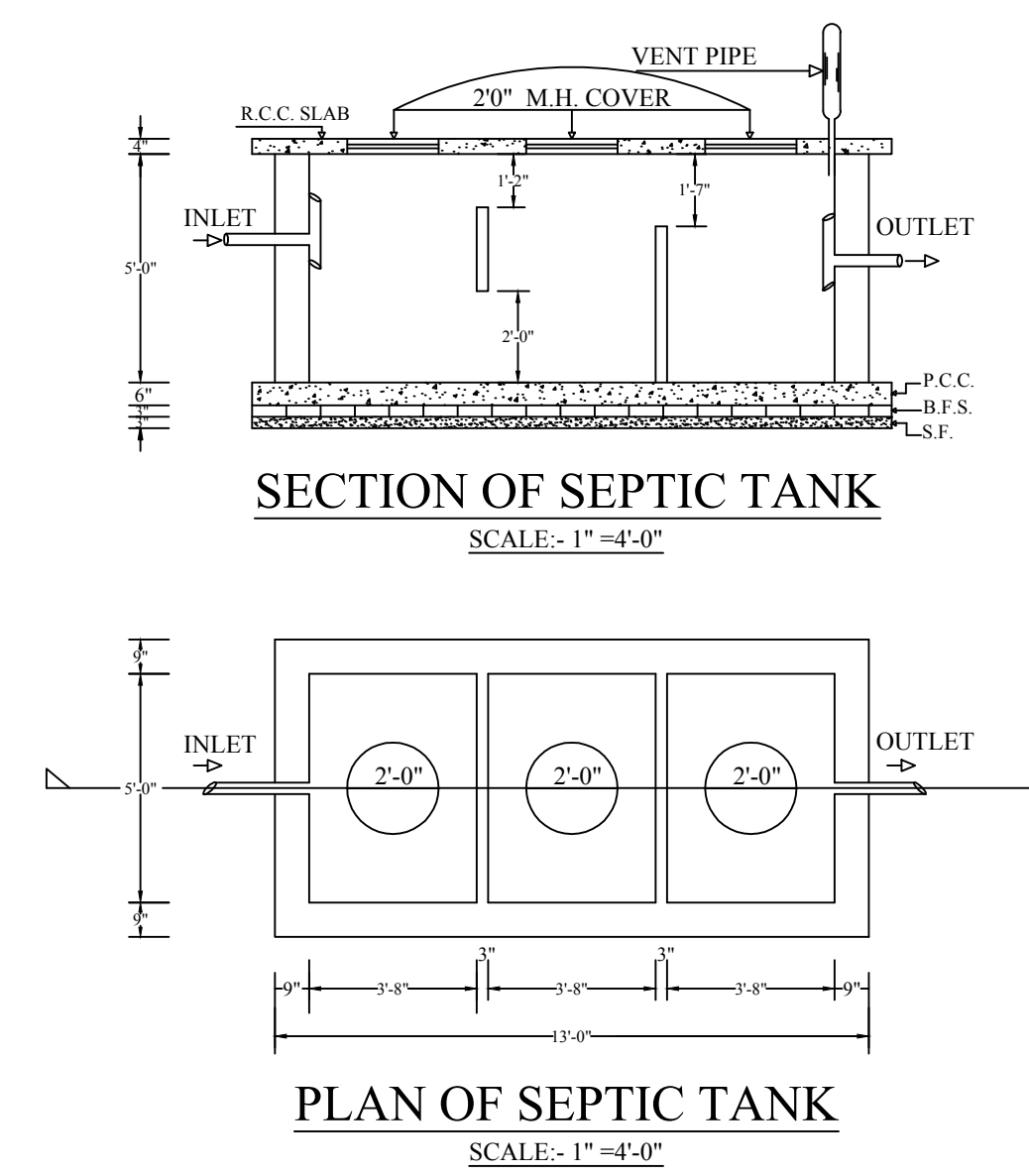
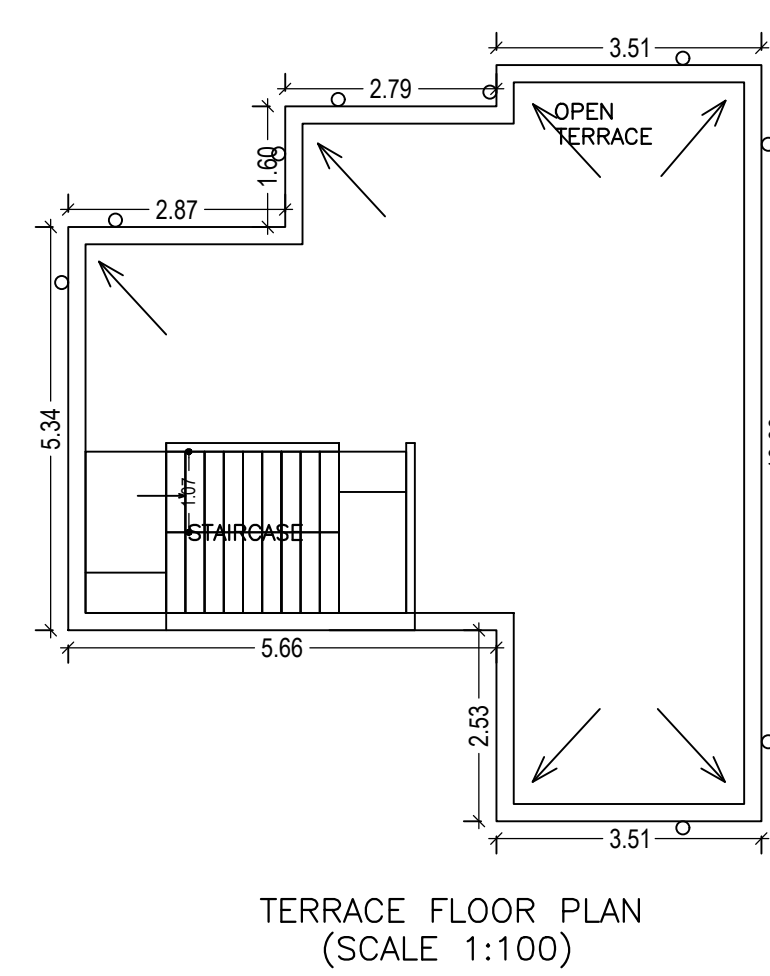
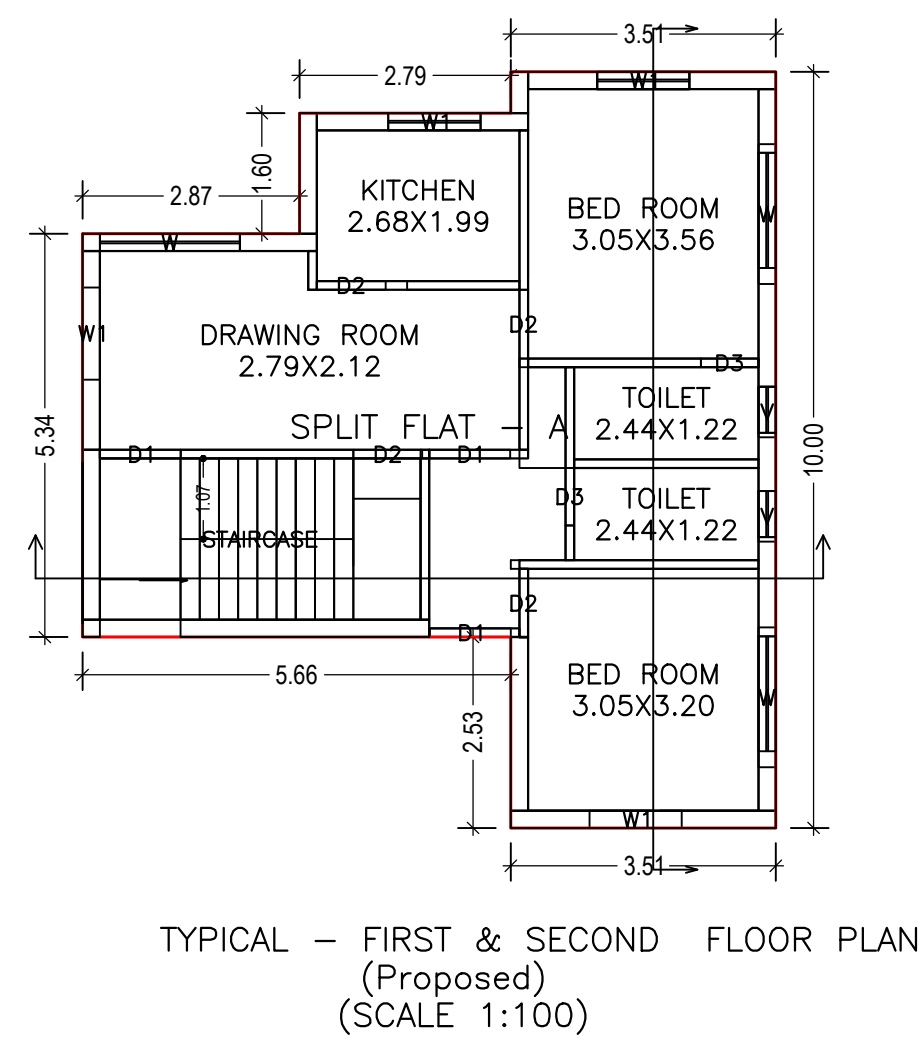
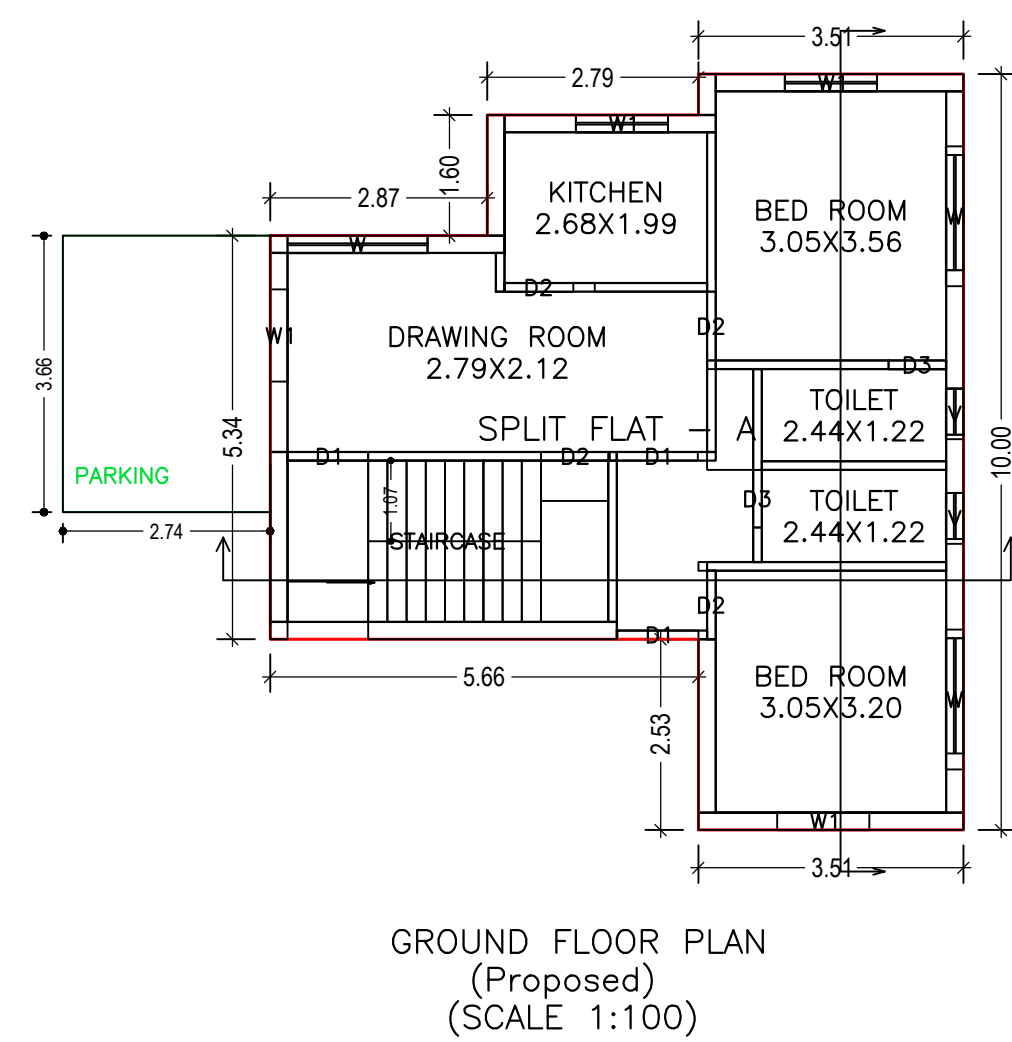
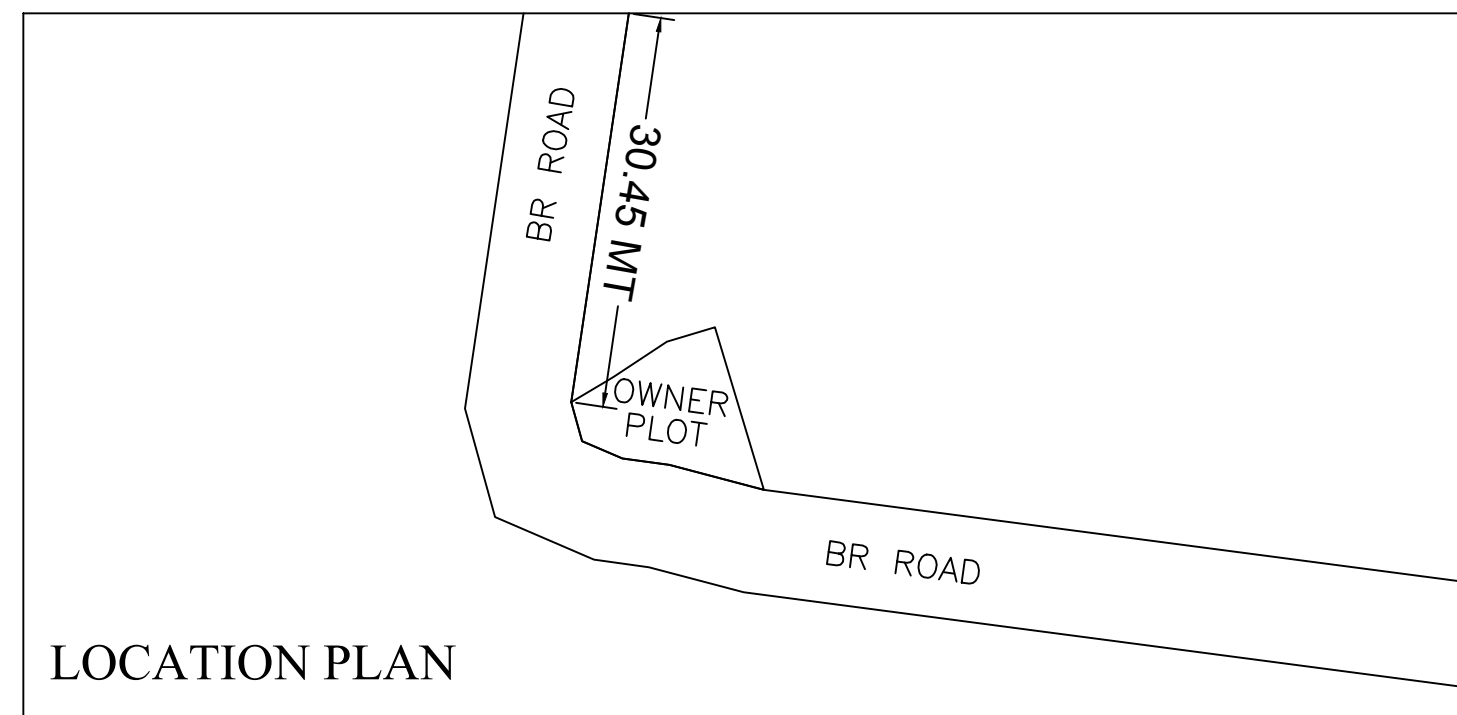
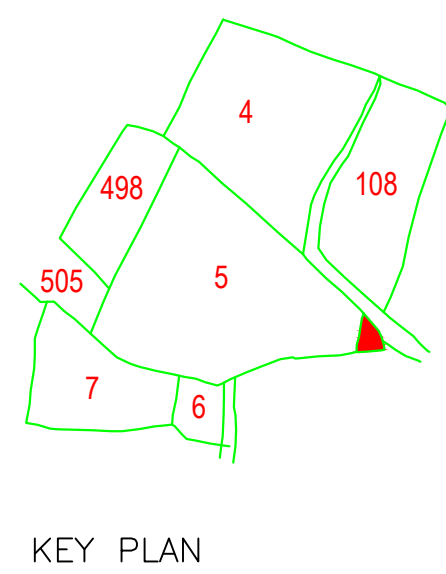
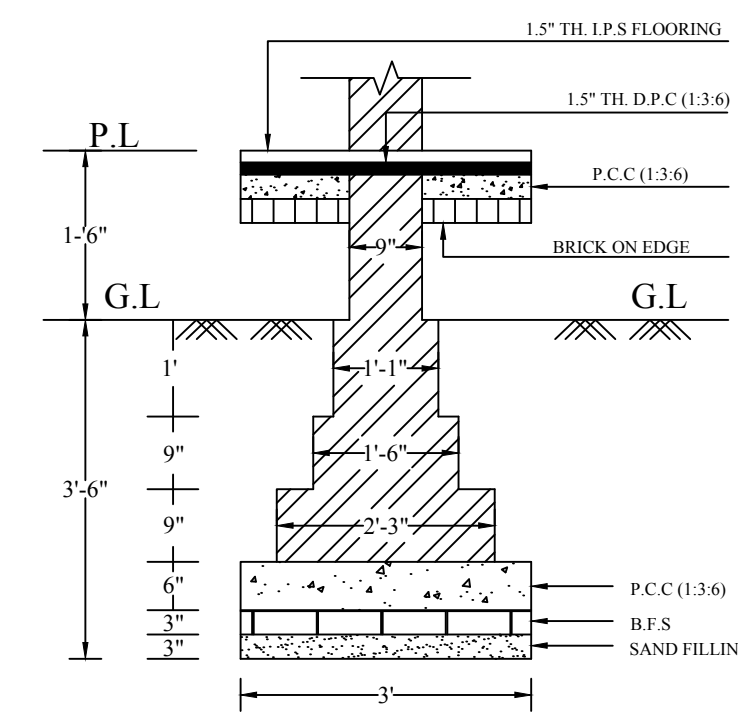

LTP NAME AND SIGNATURE PARTHA - PAL DMC/ENG/0021/2016	STRUCTURAL ENG'S NAME AND SIGNATURE	BUILDER NAME AND SIGNATURE
---	-------------------------------------	----------------------------