

Proposal Basic Information	
Proposal File No.	DMC/BP/0117/W26/2018
Owner Name	LAL JHARI DEVI
Khata No	06
Plot No	198/1170
Village Name	Bhuda
Use	Residential
SubUse	Residential Bldg/Apartment

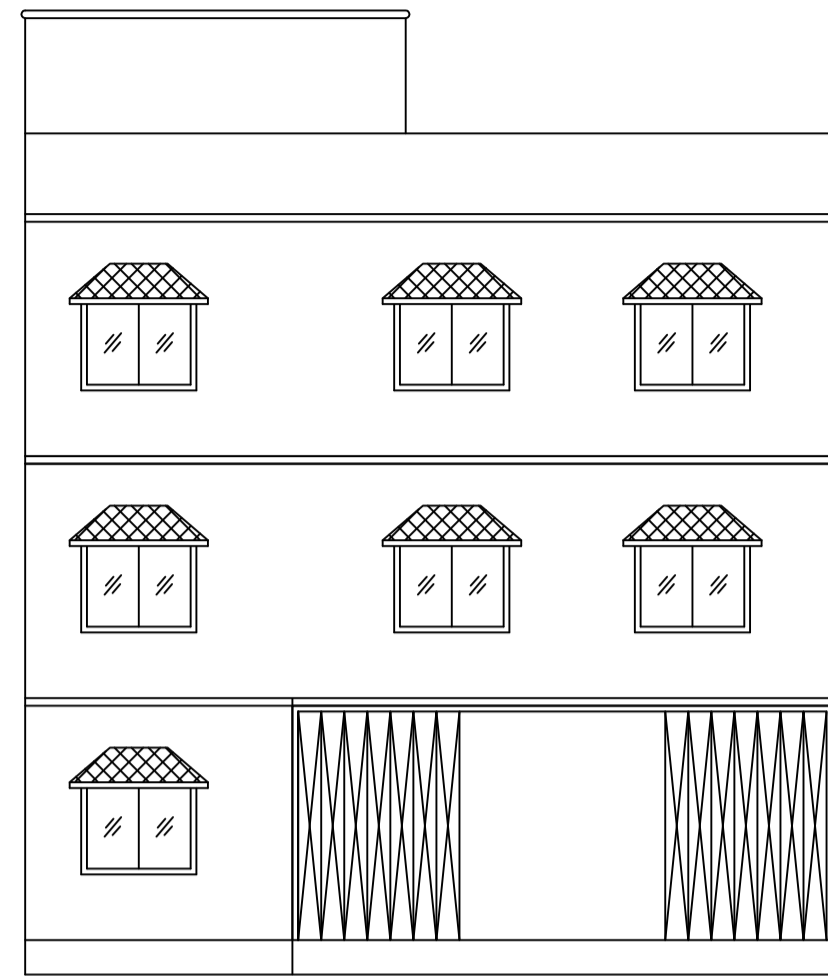

FRONT ELEVATION

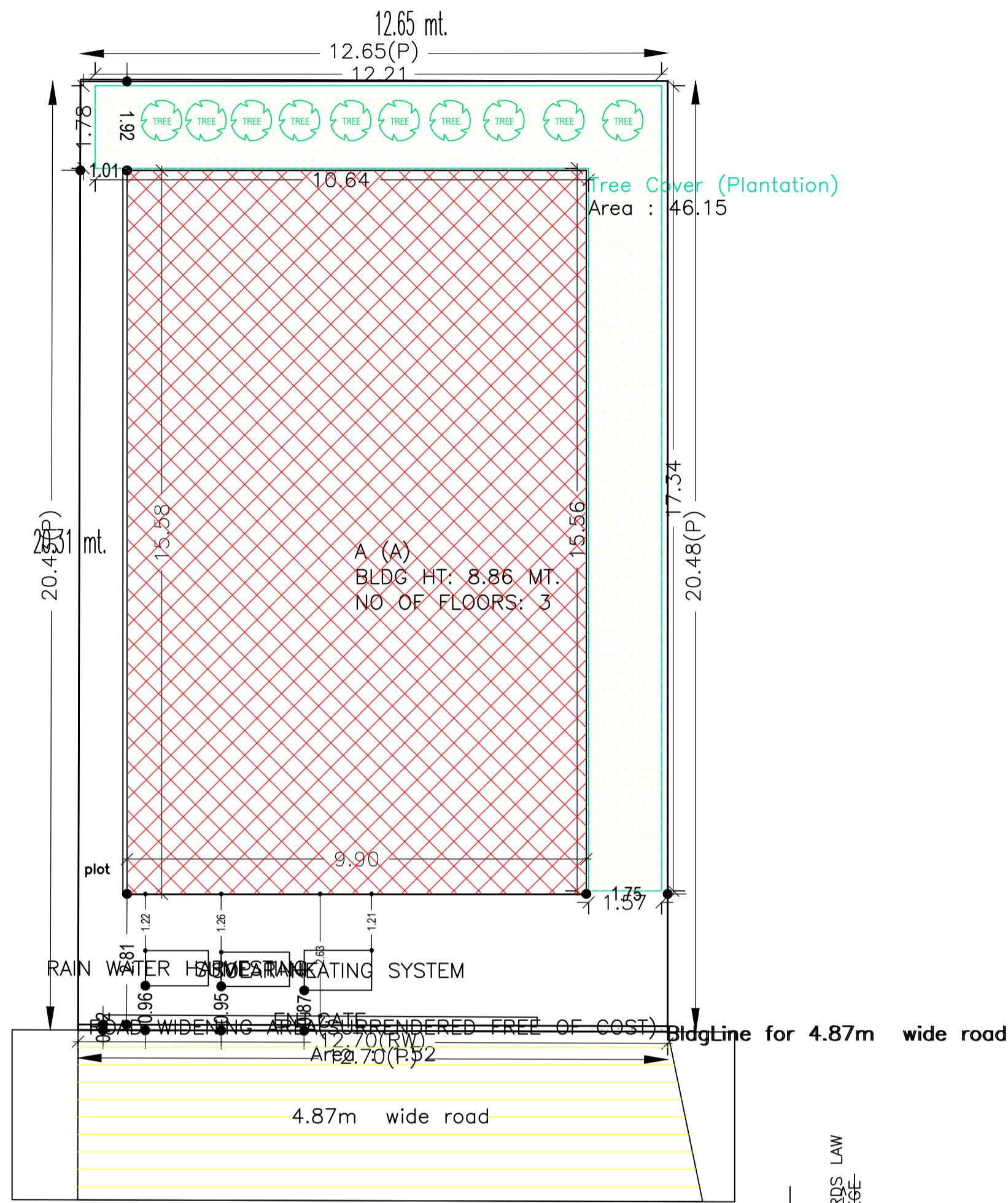
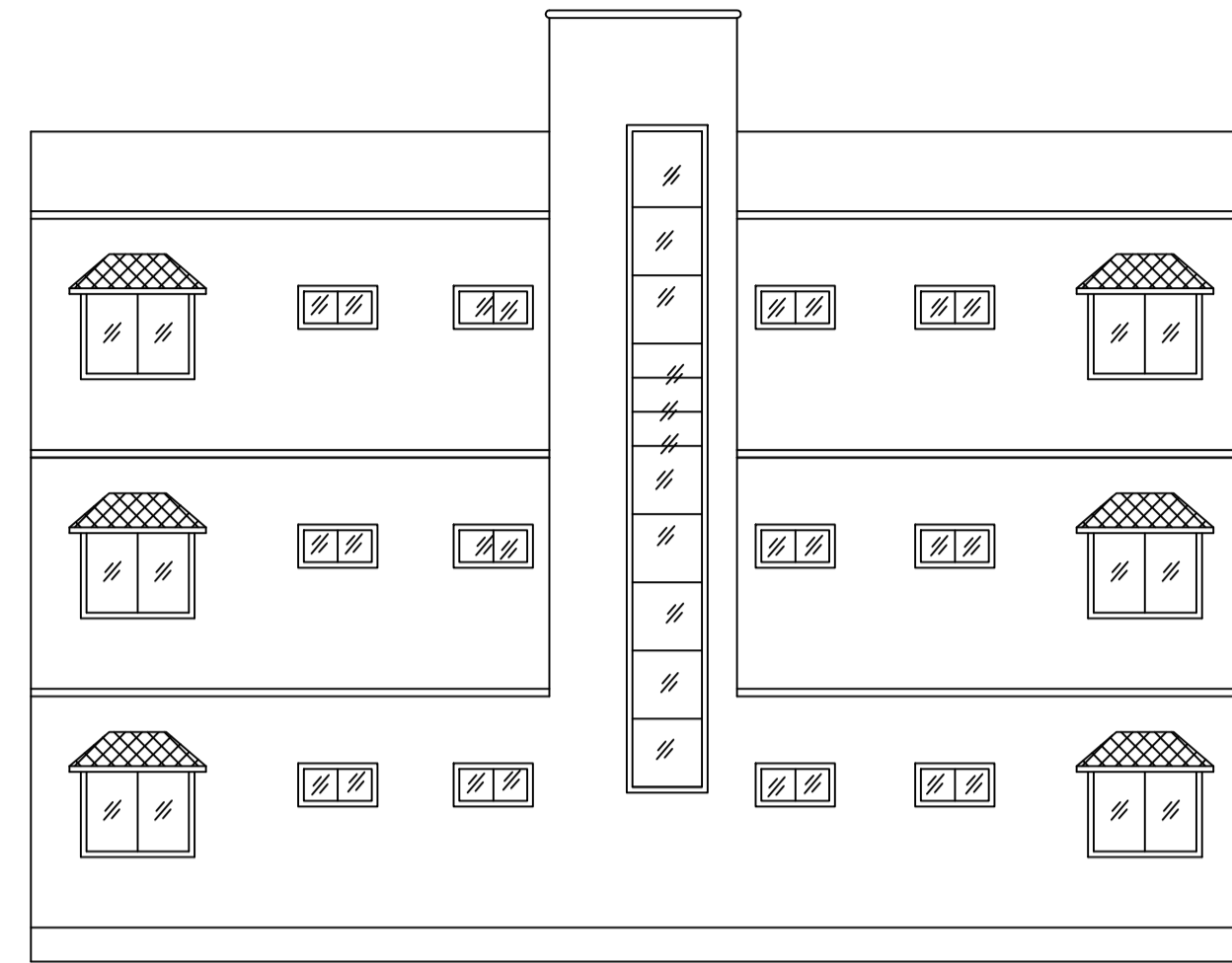

LEFT SIDE ELEVATION

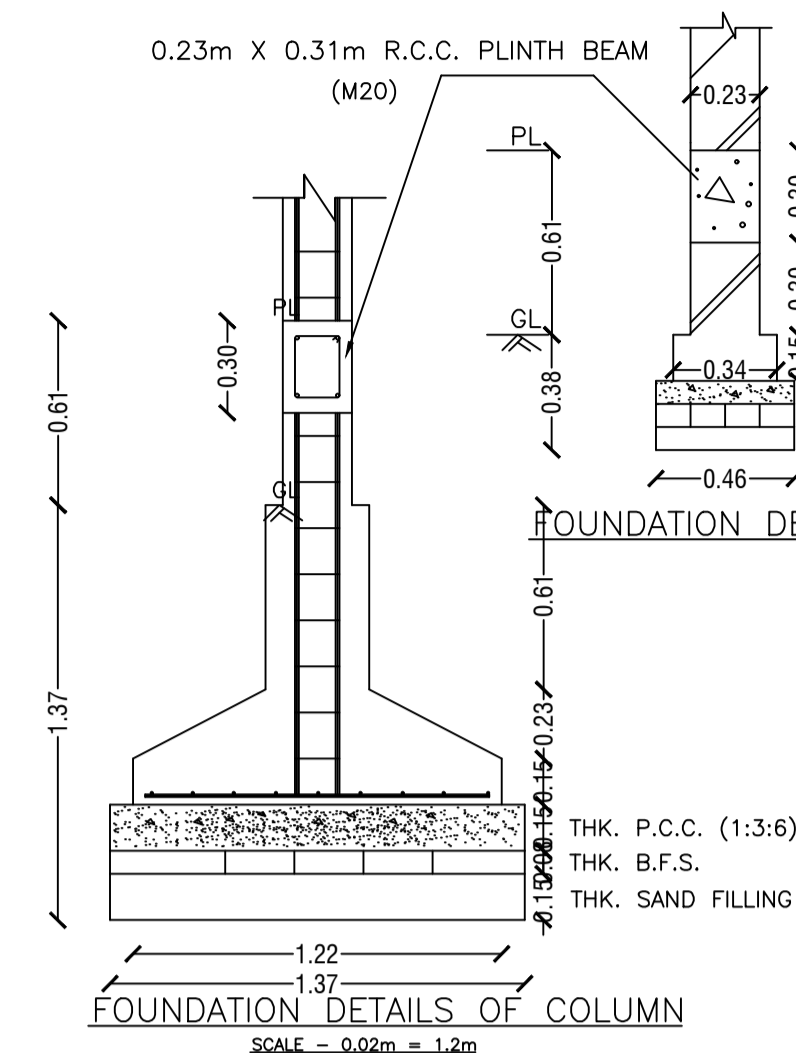

FOUNDATION DETAILS OF WALL
FOUNDATION DETAILS OF COLUMN

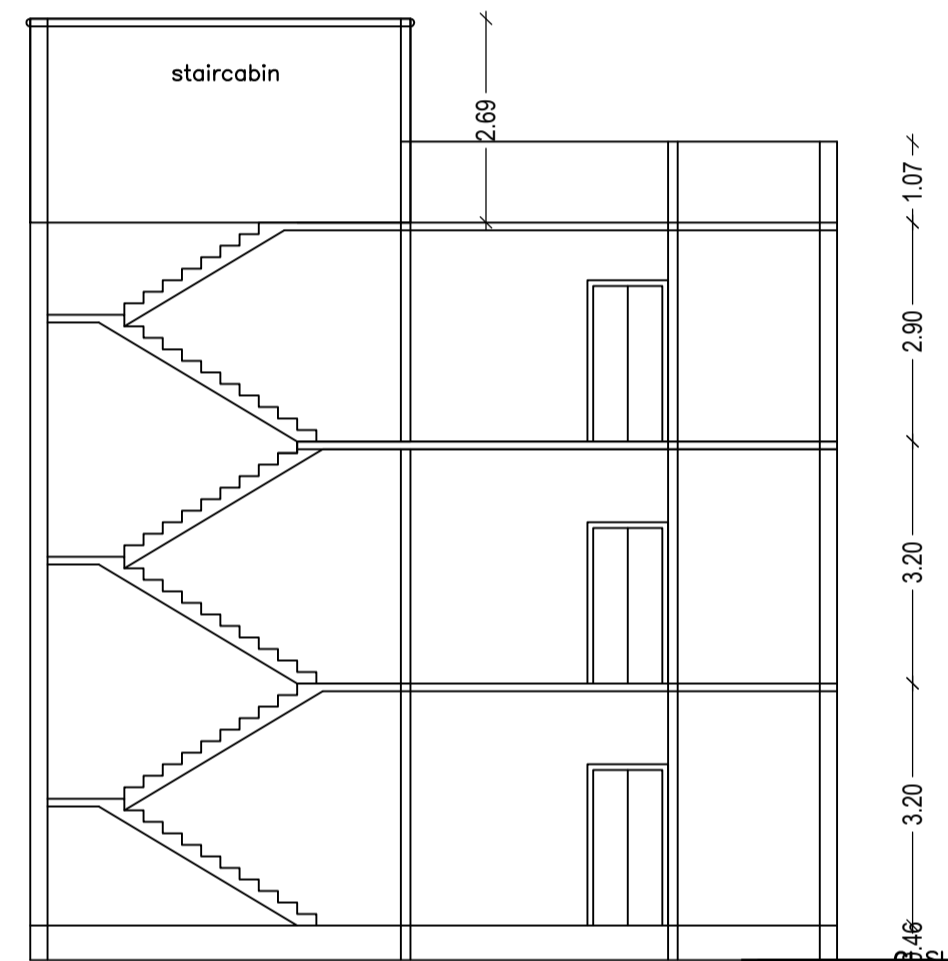

SECTION ON X-X

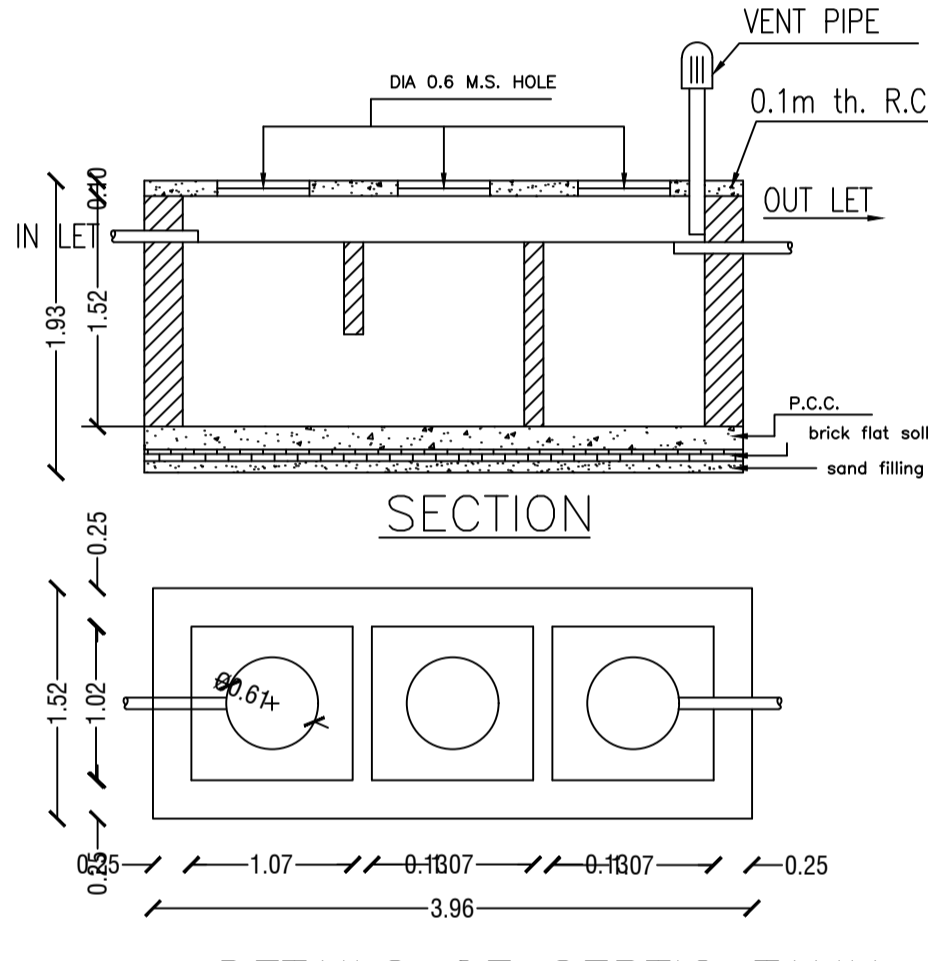

DETAILS OF SEPTIC TANK

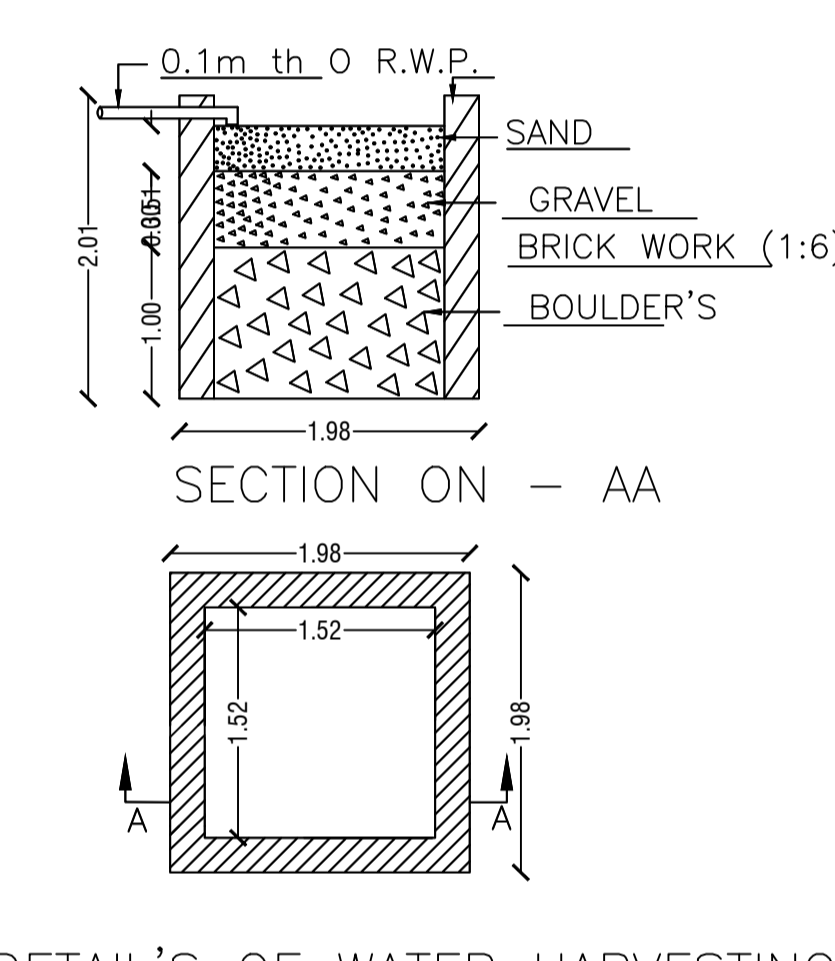

DETAIL'S OF WATER HARVESTING

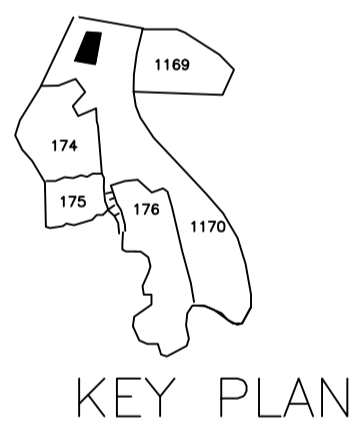

KEY PLAN

SCHEDULE OF DOOR:

BUILDING NAME	NAME	LENGTH	HEIGHT	NOS
A (A)	D	0.90	2.10	39

SCHEDULE OF WINDOW/VENTILATION:

BUILDING NAME	NAME	LENGTH	HEIGHT	NOS
A (A)	W	1.15	1.20	03
A (A)	W	1.20	1.20	21
A (A)	W	1.56	1.20	05
A (A)	W	2.22	1.20	03
A (A)	W	2.36	1.20	03
A (A)	W	2.38	1.20	07
A (A)	W	2.61	1.20	04
A (A)	W	2.85	1.20	01
A (A)	W	3.23	1.20	03
A (A)	W	4.95	1.20	01
A (A)	W	6.93	1.20	01

Building :A (A)

Floor Name	Total Built Up Area (Sq.mt.)	Proposed FAR Area (Sq.mt.) Resi.	Total FAR Area (Sq.mt.)	Total Consumed Additional FAR Area (Sq.mt.)	Tnmt (No.)
Ground Floor	154.21	154.21	154.21	154.21	01
First Floor	154.21	154.21	154.21	154.21	00
Second Floor	154.21	154.21	154.21	154.21	00
Terrace Floor	0.00	0.00	0.00	0.00	00
Total:	462.63	462.63	462.63	462.63	01
Total Number of Same Buildings	1				
Total:	462.63	462.63	462.63	462.63	01

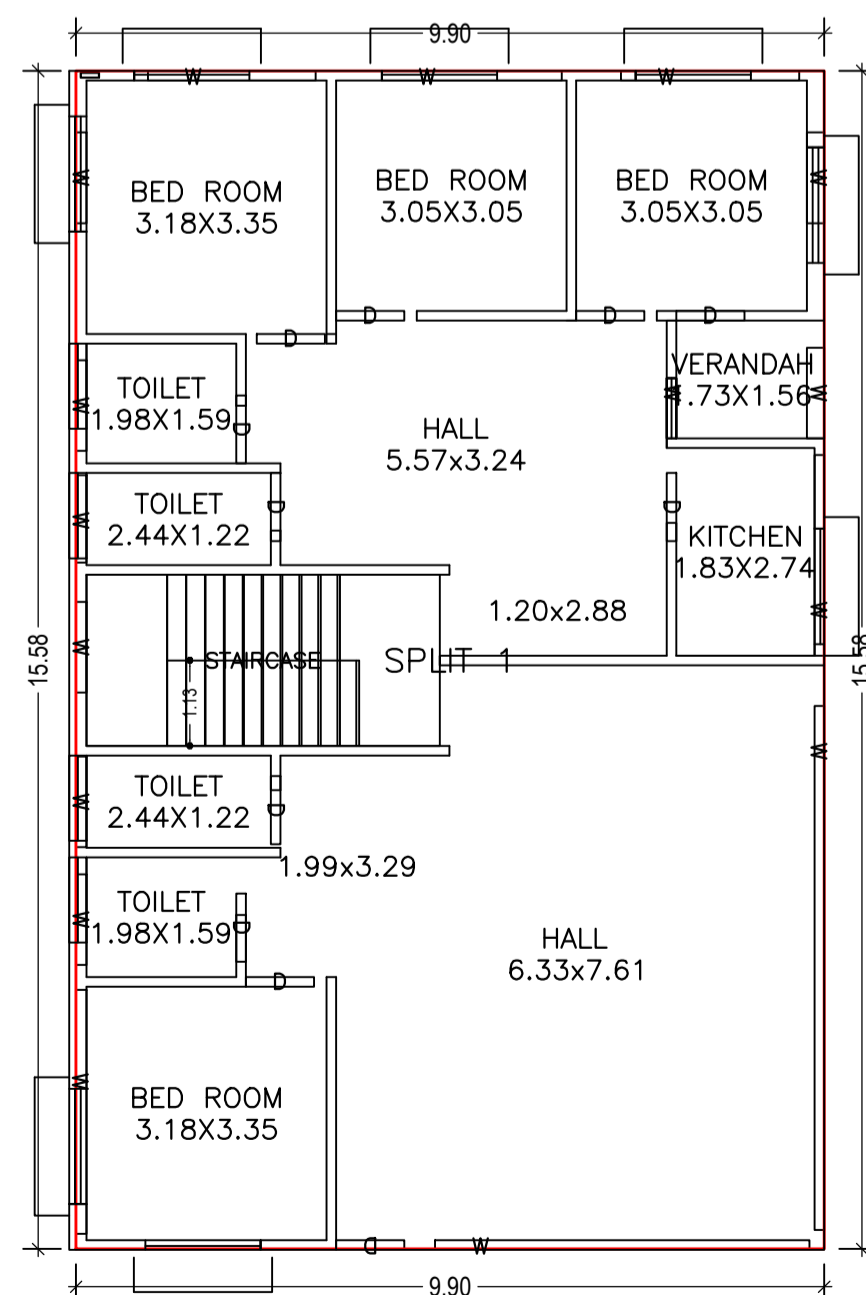

GROUND FLOOR PLAN (Proposed) (SCALE 1:100)

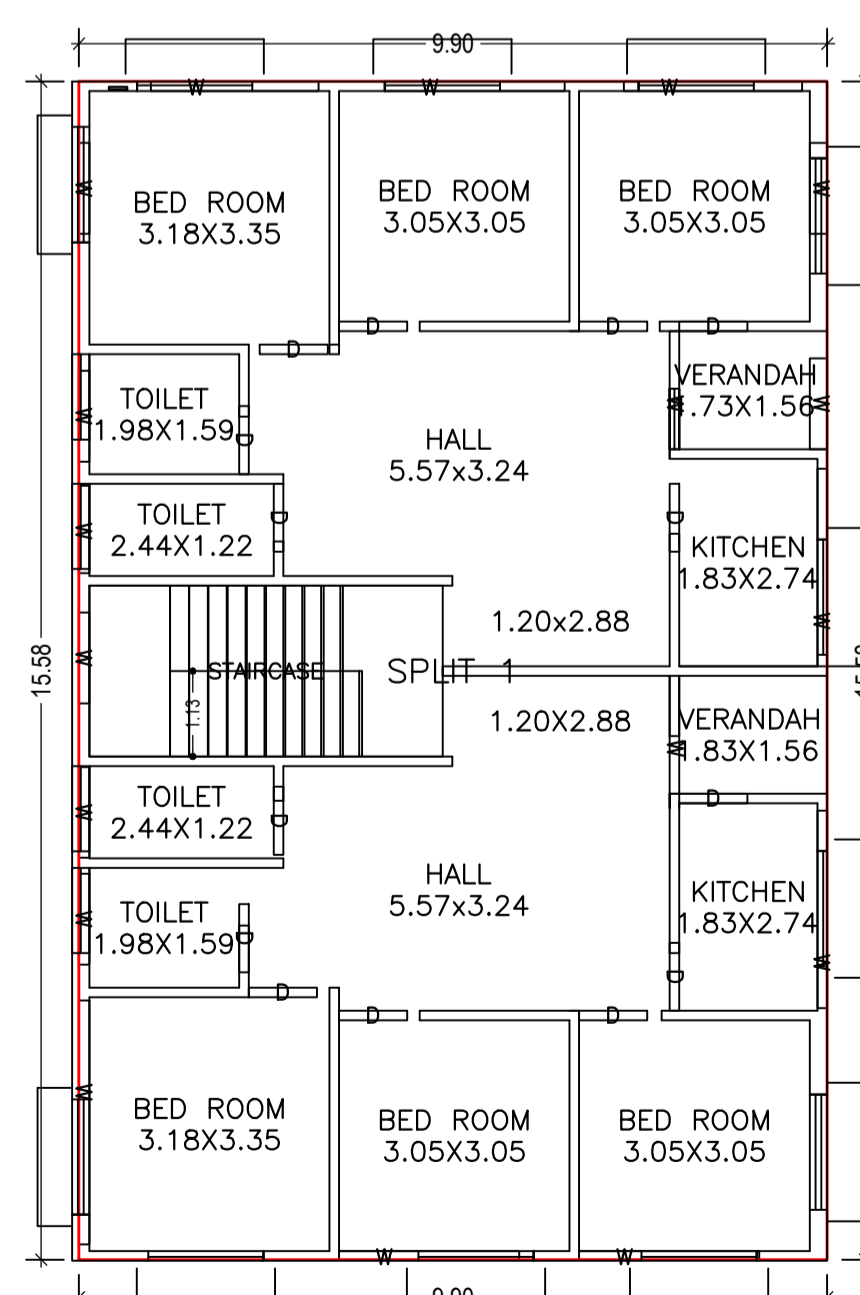

TYPICAL - 1, 2 FLOOR PLAN (Proposed) (SCALE 1:100)

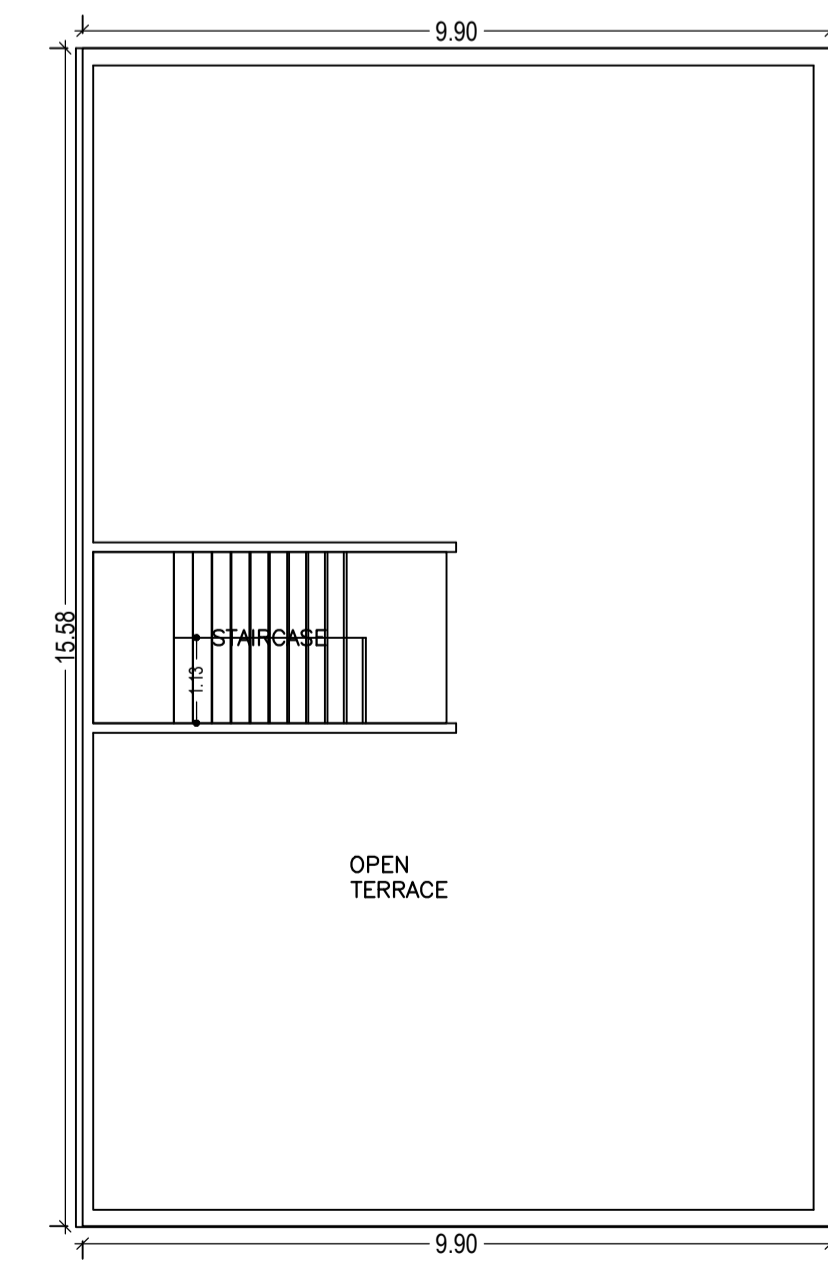

TERRACE FLOOR PLAN (SCALE 1:100)

AREA STATEMENT		VERSION NO. : 1.0.28
DHANBAD MUNICIPAL CORPORATION		VERSION DATE: 30/06/2018
PROJECT DETAIL:		
Region: JHARKHAND URBAN LOCAL BODIES	Plot Use: Residential	
District: DHANBAD	Plot SubUse: Residential Bldg/Apartment	
Authority: DHANBAD MUNICIPAL CORPORATION	PlotNearbyReligiousStructure: NA	
Inward: No: DMC/BP/0117/W26/2018	PlotSubPlot No: 198/1170	
Application Type: General Proposal	North: Plot No. - SAME PLOT	
Project Type: Building Permission	South: Road Width - 4.87	
Nature of Development: New	East: Plot No. - RAJESHWAR SINGH	
Location of Development Area: Old Area	West: Plot No. - SAME PLOT	
AREA DETAILS:		SQ.MT.
AREA OF PLOT (Minimum)	(A)	259.30
Deduction for NetPlot Area		
Surrender Free of Cost		1.52
Total		1.52
NET AREA OF PLOT(Gross Plot Area - Deduction from Gross Plot area)	(A-Deductions)	257.78
Deduction for Balance Plot Area(from Gross Plot Area)		
Surrender Free of Cost		1.52
Common Plot		46.15
Total		47.67
BALANCE AREA OF PLOT(Net Plot Area - Recreational/Amenity space)	(A-Deductions)	211.63
PLOT AREA FOR COVERAGE(Net Plot Area)	(A-Deductions)	257.78
Plot Area for FAR (Net Plot Area + RoadWidening Area)	(A-Deductions)	259.30
COVERAGE CHECK		
Permissible Coverage area (60.00 %)		154.67
Proposed Coverage Area (59.82 %)		154.21
Total Prop. Coverage Area (59.82 %)		154.21
Balance coverage area (0.18 %)		0.46
FAR CHECK		
Perm. FAR Area (1.80)		466.74
Total Perm. FAR area		466.74
Residential FAR		462.64
Proposed FAR Area		462.64
Total Proposed FAR Area		462.64
Consumed FAR (Factor)		1.78
Balance FAR Area		4.10
BUILT UP AREA CHECK		
Total Proposed BuiltUp Area		462.63
ARCHITECT (Regd)		NISHANT KUMAR
ENGINEER (Regd)		
SUPERVISOR (Regd)		
OWNER (Regd)		LAL JHARI DEVI
DEVELOPMENT AUTHORITY		LOCAL BODY

COLOR INDEX	
PLOT BOUNDARY	Black
ABUTTING ROAD	Red
PROPOSED CONSTRUCTION	Green
COMMON PLOT	Yellow
ROAD WIDENING AREA	Blue
EXISTING (To be retained)	Light Blue
EXISTING (To be demolished)	Light Yellow

Buildingwise Floor FAR Details

Floor Name	Building Name A (A)		Total	
	Proposed Built Up Area (Sq.mt.)	Proposed FAR Area (Sq.mt.)	Total Proposed Built Up Area (Sq.mt.)	Total FAR Area (Sq.mt.)
Ground Floor	154.21	154.21	154.21	154.21
First Floor	154.21	154.21	154.21	154.21
Second Floor	154.21	154.21	154.21	154.21
Terrace Floor	0.00	0.00	0.00	0.00
Total:	462.63	462.63	462.63	462.63

Building USE/SUBUSE Details

Building Name	Building Use	Building SubUse	Building Structure
A (A)	Residential	Residential Bldg/Apartment	Non-Highrise

FAR & Tenement Details (Table 4c-1)

Building	No. of Same Bldg	Total Built Up Area (Sq.mt.)	Proposed FAR Area (Sq.mt.) Resi.	Total FAR Area (Sq.mt.)	Total Consumed Additional FAR Area (Sq.mt.)	Tnmt (No.)
A (A)	1	462.63	462.63	462.63	462.63	01
Grand Total:	1	462.63	462.63	462.63	462.63	01

LTP NAME AND SIGNATURE	STRUCTURAL ENG'S NAME AND SIGNATURE	BUILDER NAME AND SIGNATURE
NISHANT KUMAR DMC/ENG/0006/2016		

Proposal Basic Information	
Proposal File No.	DMC/BP/0117/W26/2018
Owner Name	LAL JHARI DEVI
Khata No	06
Plot No	198/1170
Village Name	Bhuda
Use	Residential
SubUse	Residential Bldg/Apartment

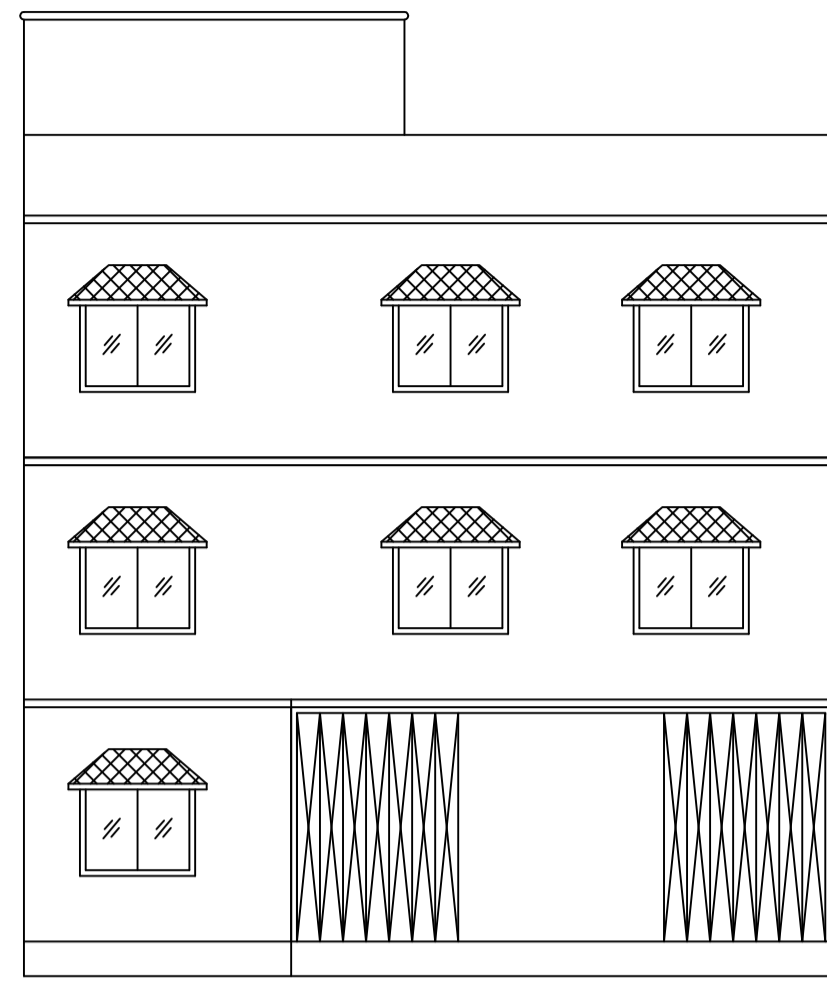

FRONT ELEVATION

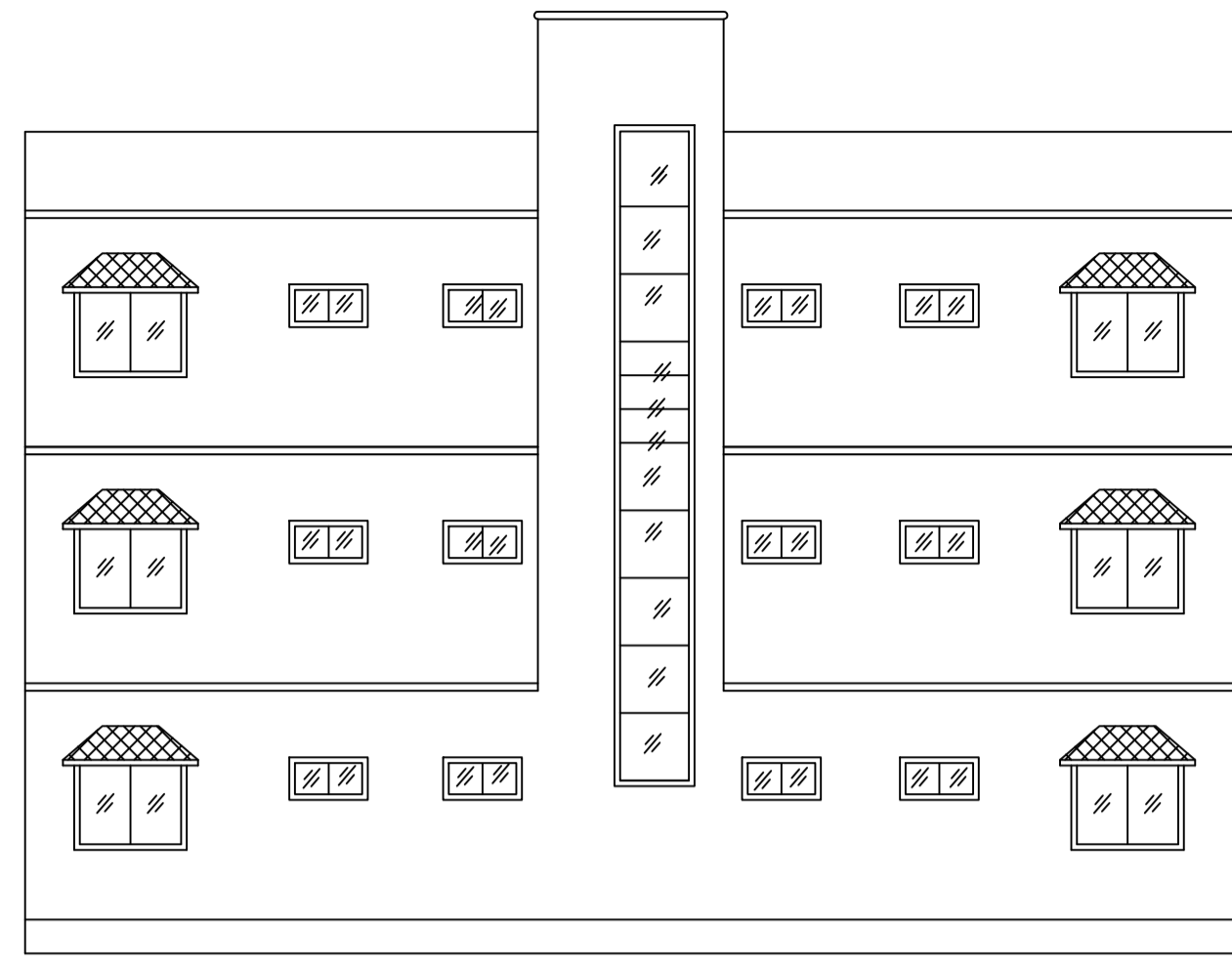

LEFT SIDE ELEVATION

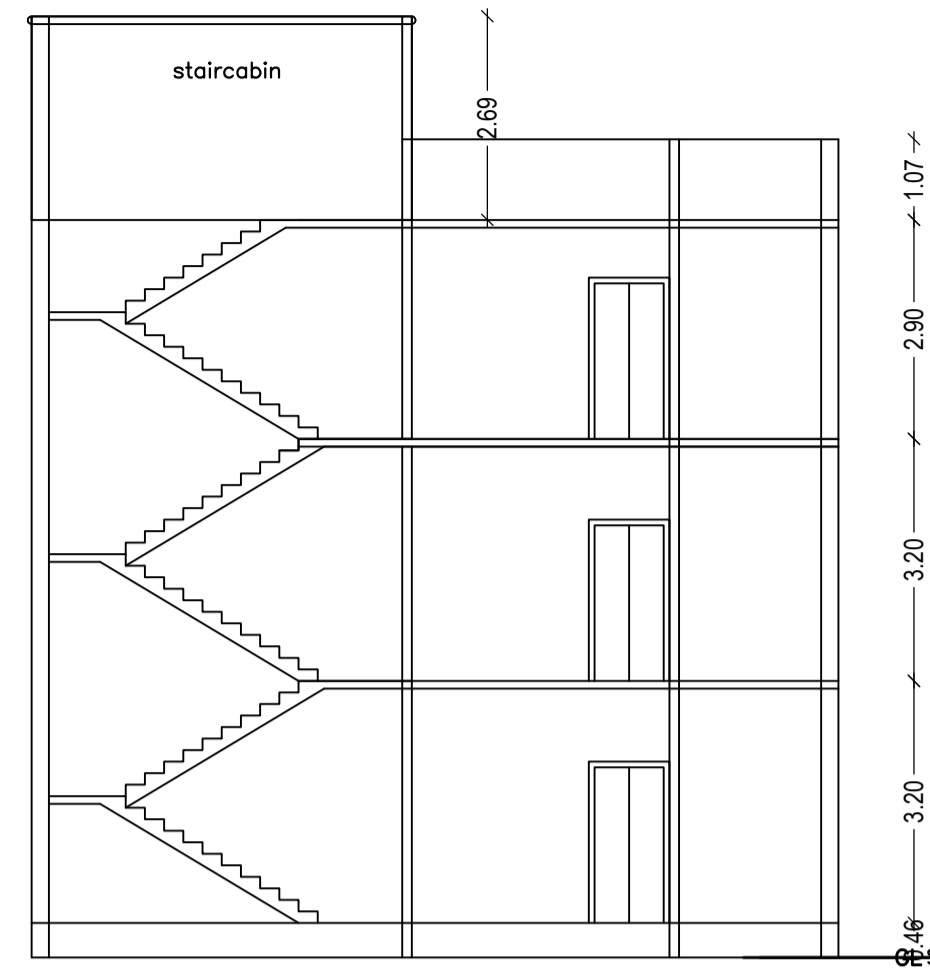

SECTION ON X-X

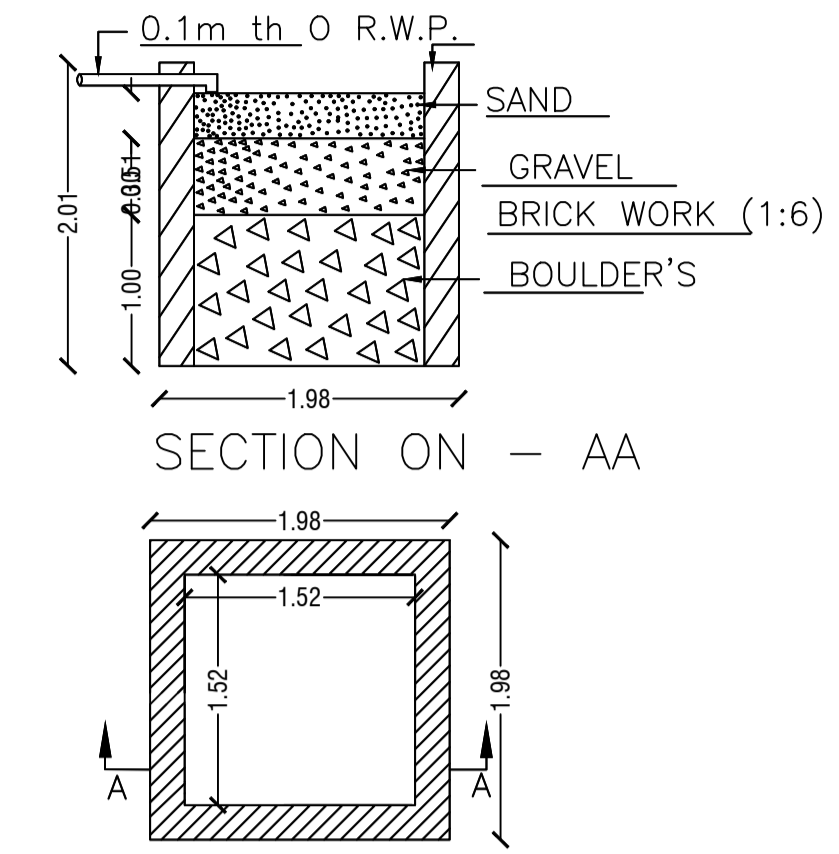

DETAIL'S OF WATER HARVESTING

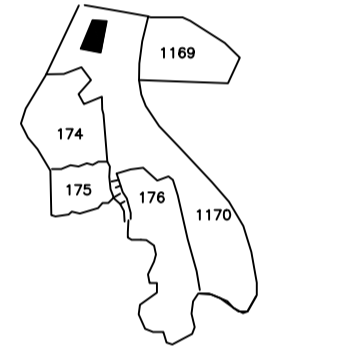

KEY PLAN

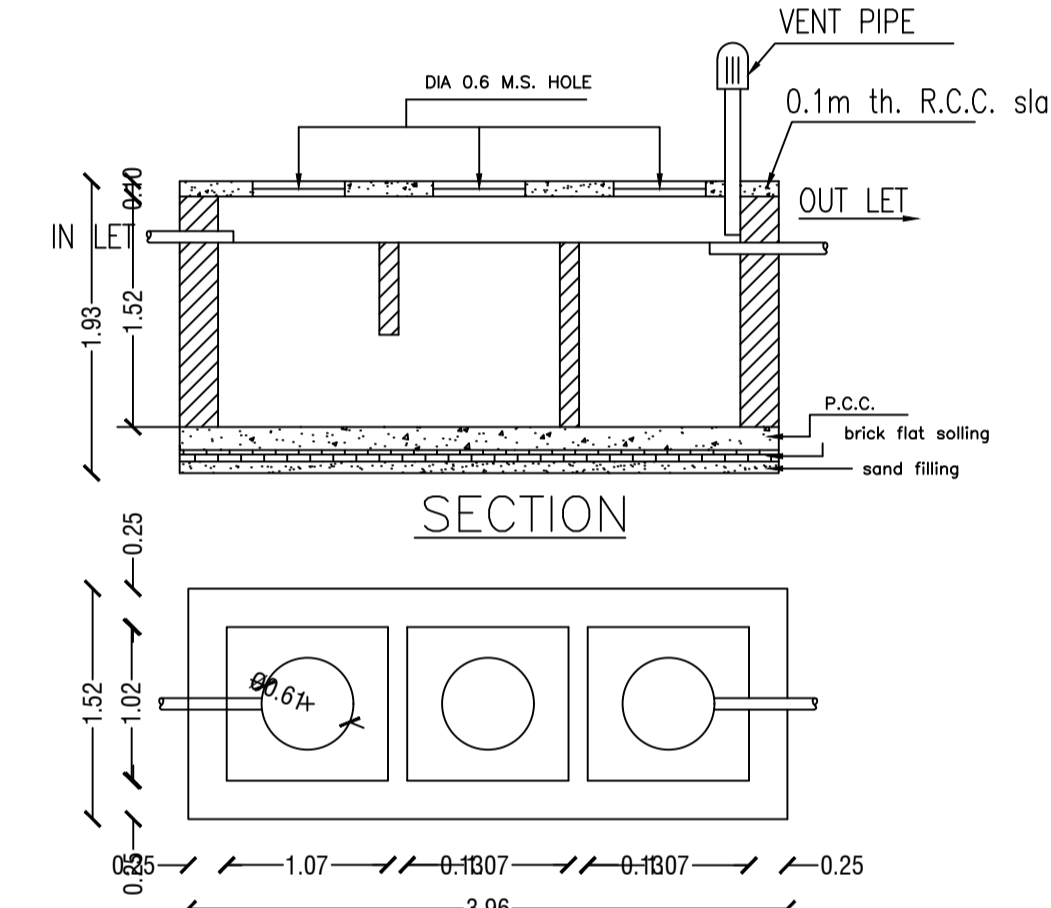
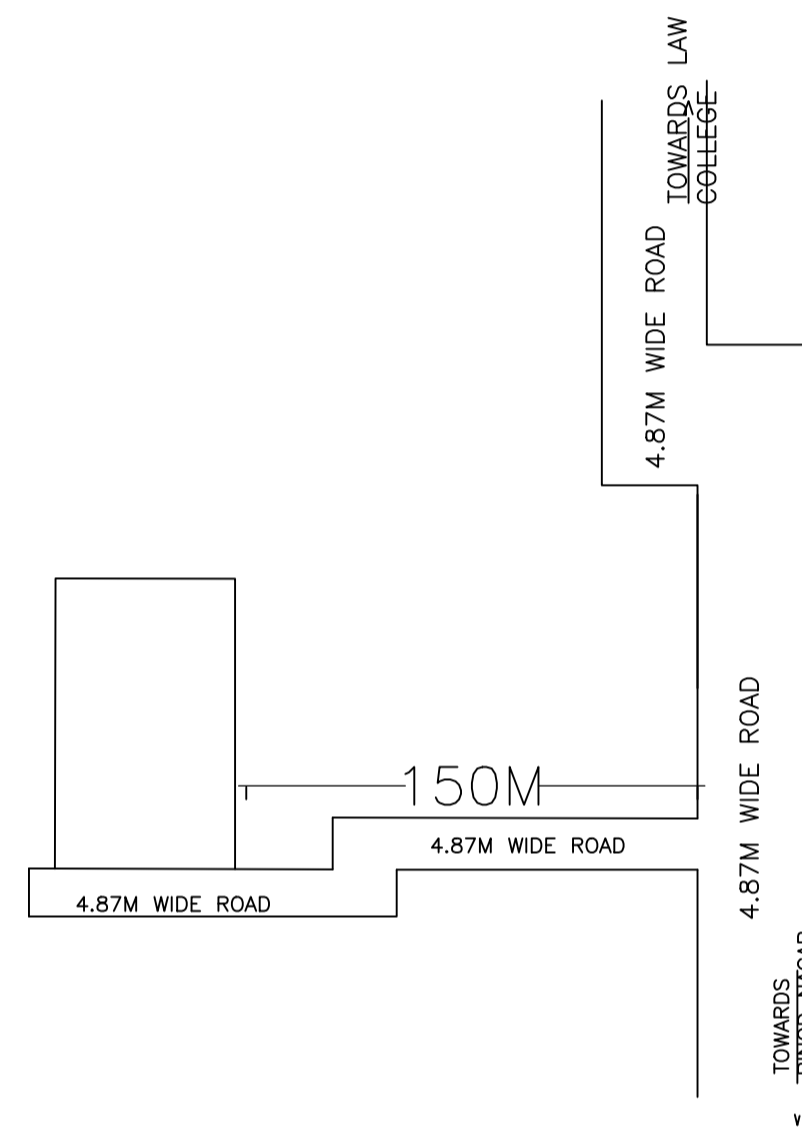

DETAILS OF SEPTIC TANK

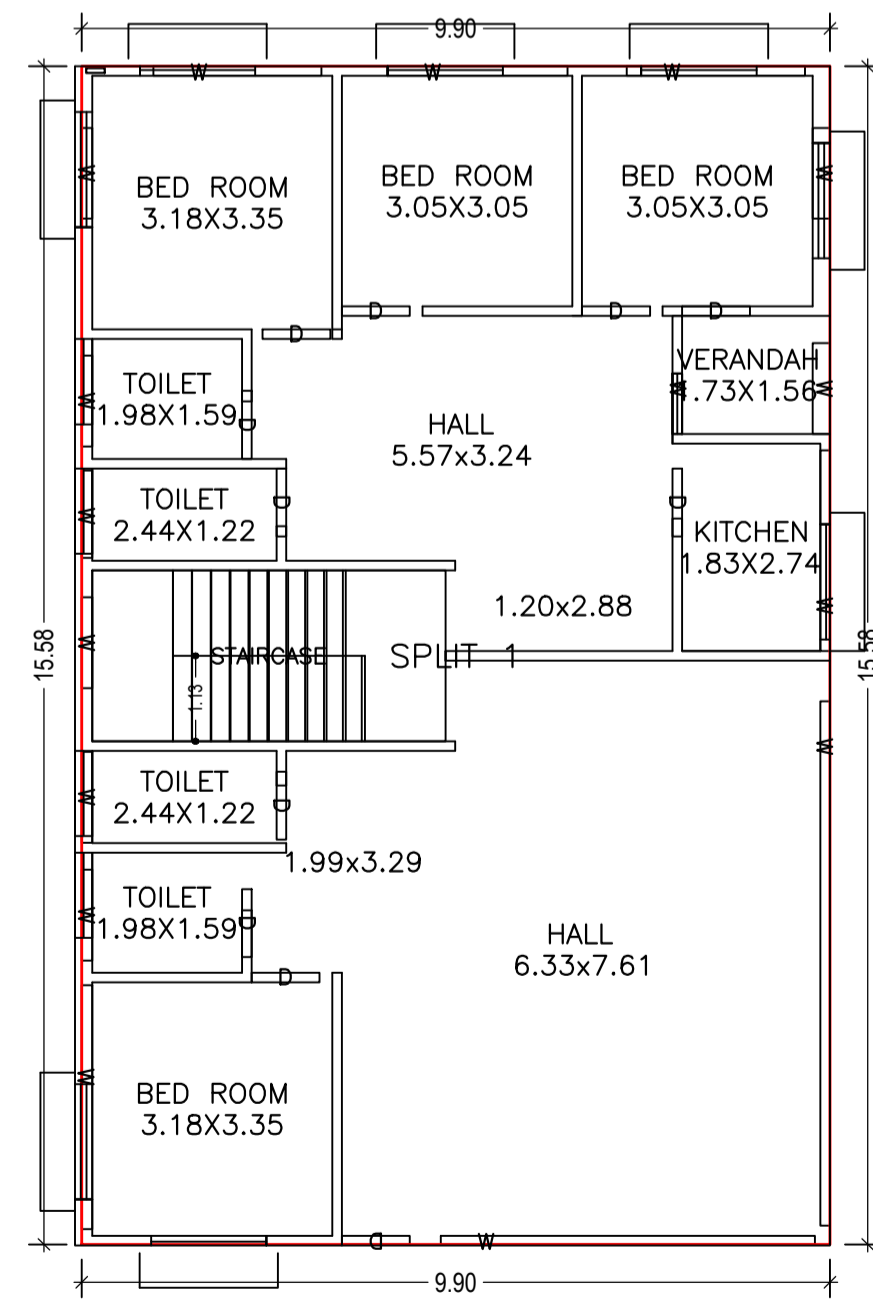

GROUND FLOOR PLAN
(Proposed)
(SCALE 1:100)

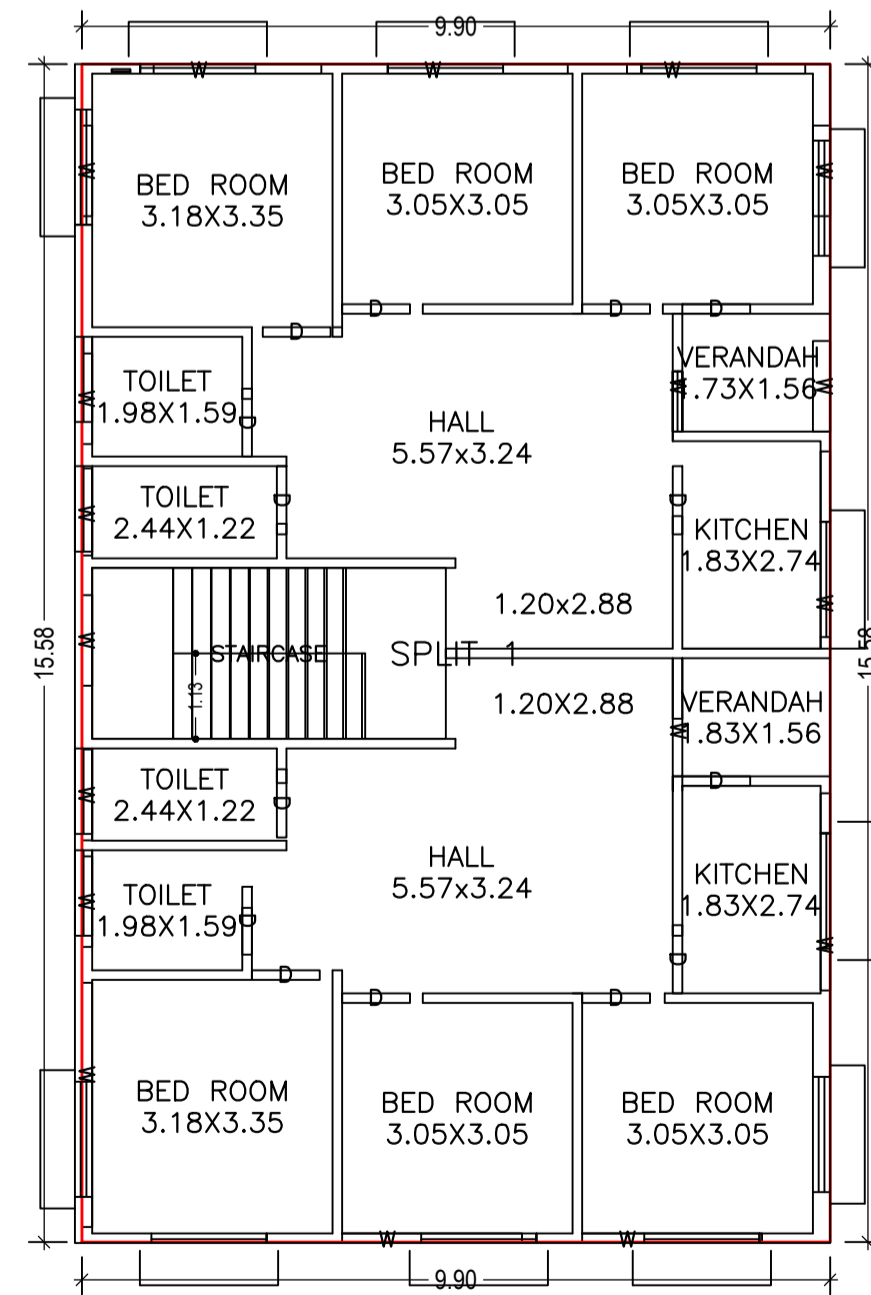

TYPICAL - 1, 2 FLOOR PLAN
(Proposed)
(SCALE 1:100)

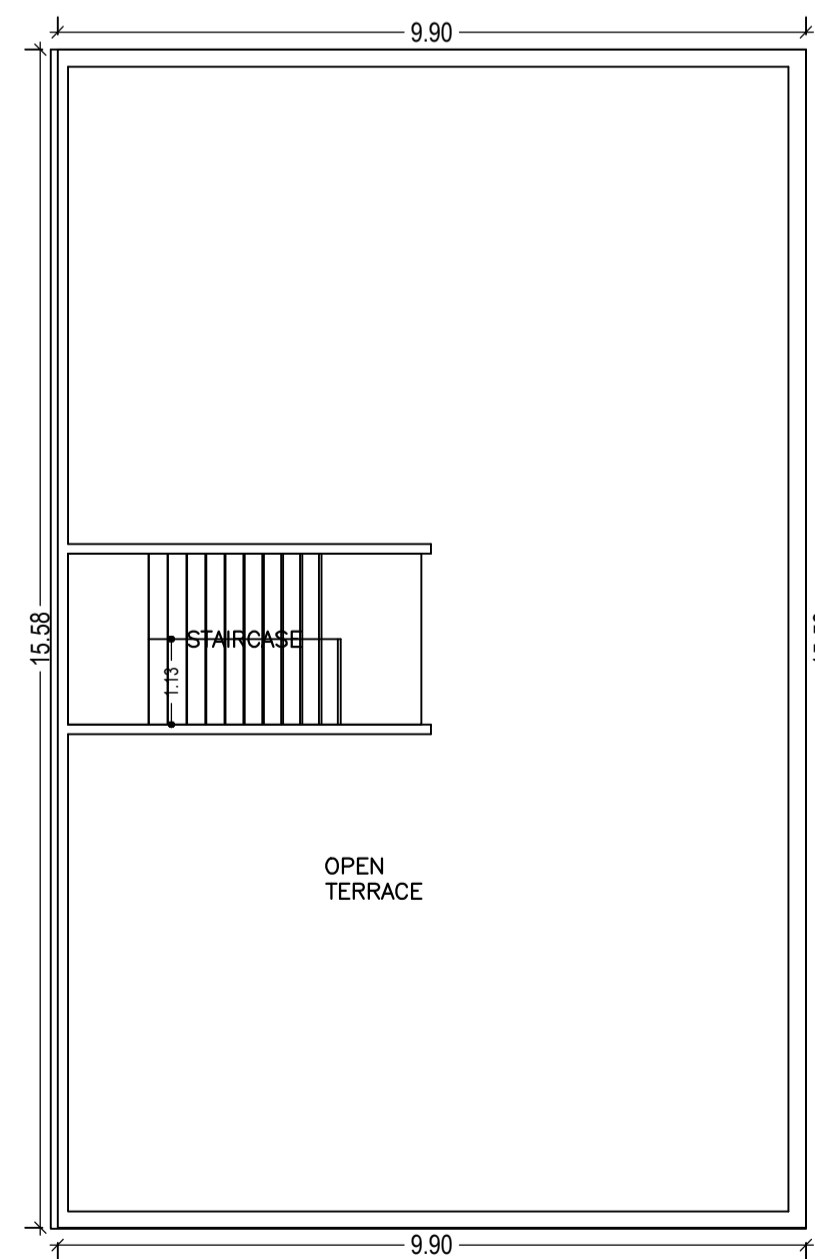

TERRACE FLOOR PLAN
(SCALE 1:100)

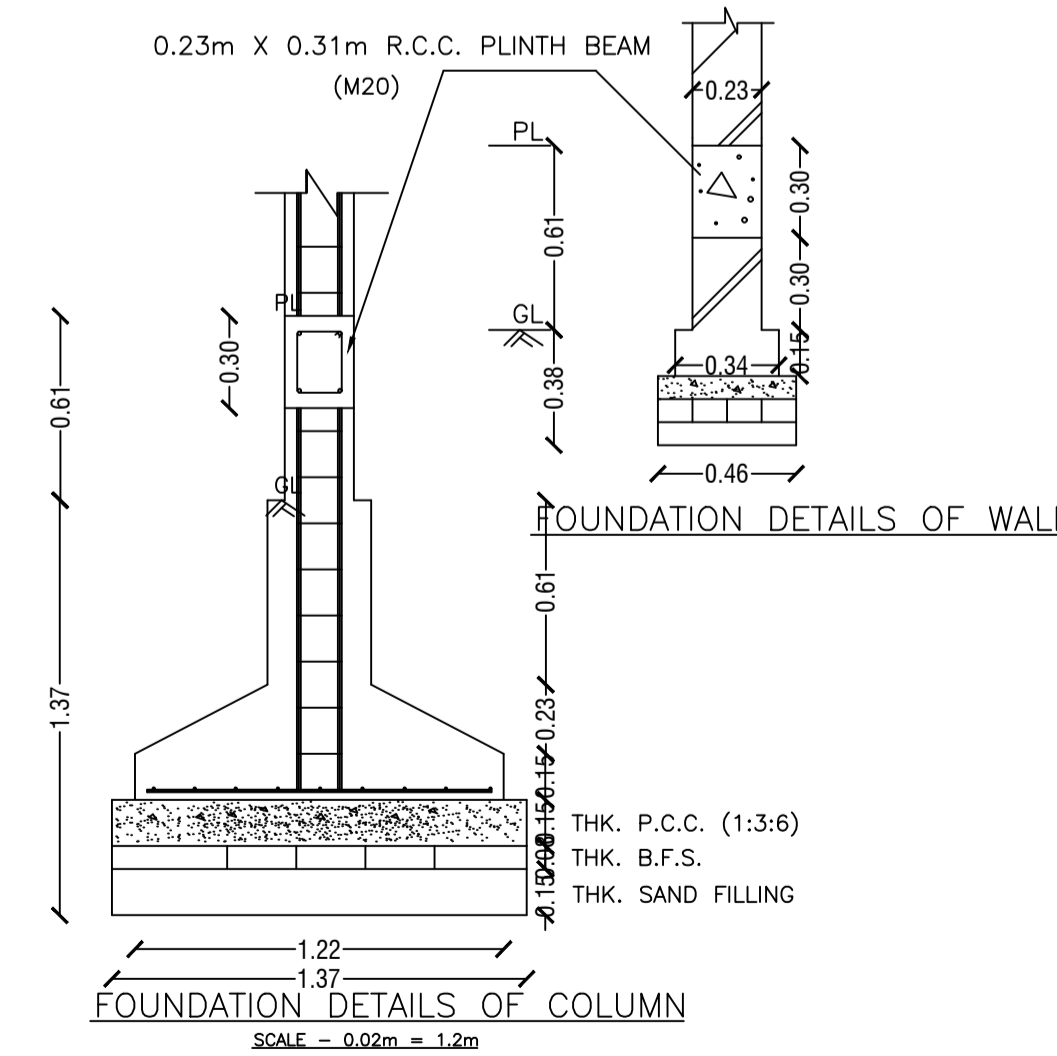

FOUNDATION DETAILS OF WALL
FOUNDATION DETAILS OF COLUMN
SCALE - 0.02m = 1.2m

LTP NAME AND SIGNATURE	STRUCTURAL ENG'S NAME AND SIGNATURE	BUILDER NAME AND SIGNATURE
NISHANT KUMAR DMC/ENG/0006/2016		

Proposal Basic Information	
Proposal File No.	DMC/BP/0117/W26/2018
Owner Name	LAL JHARI DEVI
Khata No	06
Plot No	198/1170
Village Name	Bhuda
Use	Residential
SubUse	Residential Bldg/Apartment

LTP NAME AND SIGNATURE	STRUCTURAL ENG'S NAME AND SIGNATURE	BUILDER NAME AND SIGNATURE
NISHANT KUMAR DMC/ENG/0006/2016		