

| Proposal Basic Information | |
|----------------------------|----------------------------|
| Proposal File No. | DMC/BP/0123/W23/2018 |
| Owner Name | USHA VERMA |
| Khata No | 8, 56 |
| Plot No | 611,613 |
| Village Name | Kolakusma |
| Use | Residential |
| SubUse | Residential Bldg/Apartment |

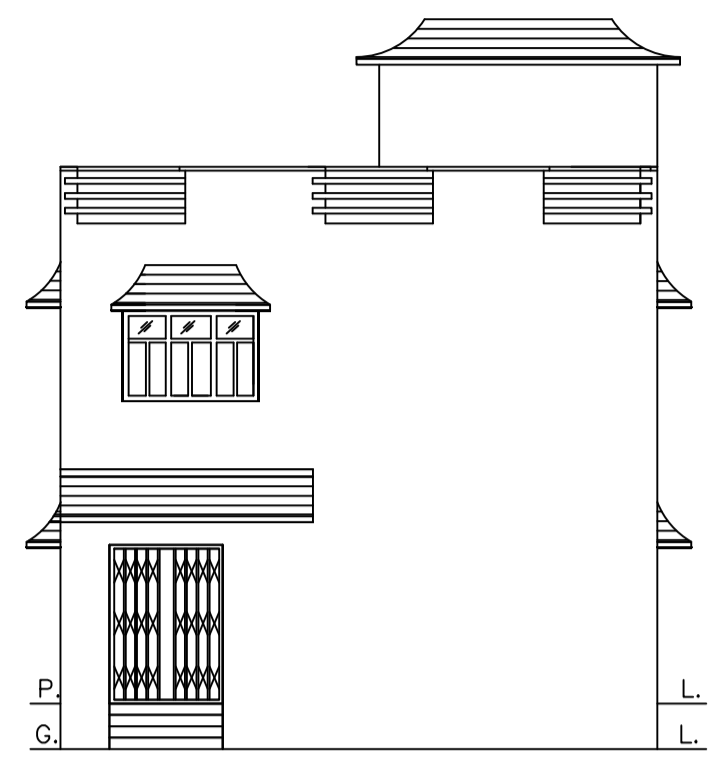

FRONT ELEVATION

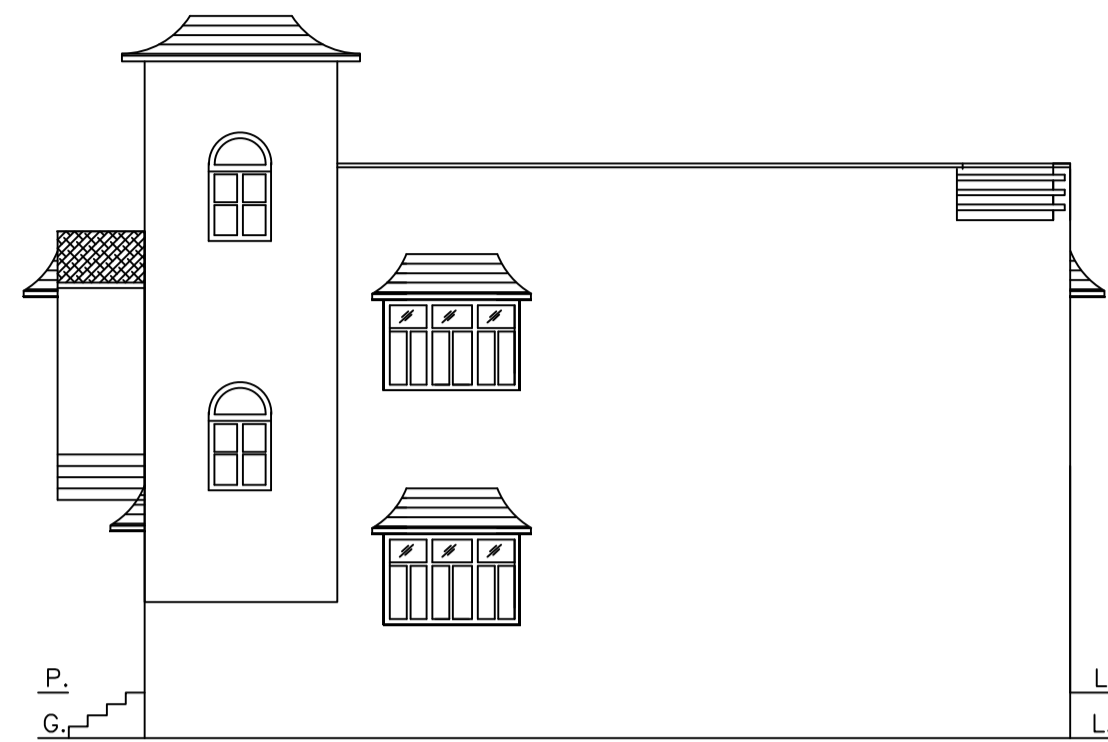

RIGHT SIDE ELEVATION

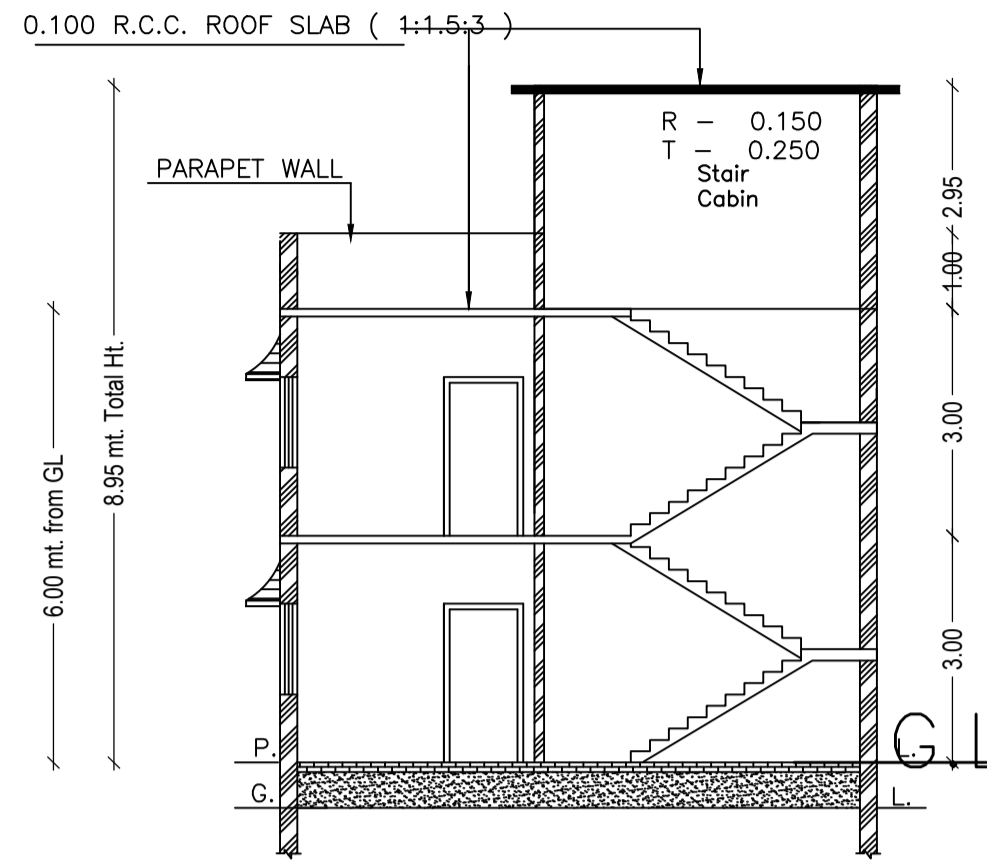

SECTION ON - XX

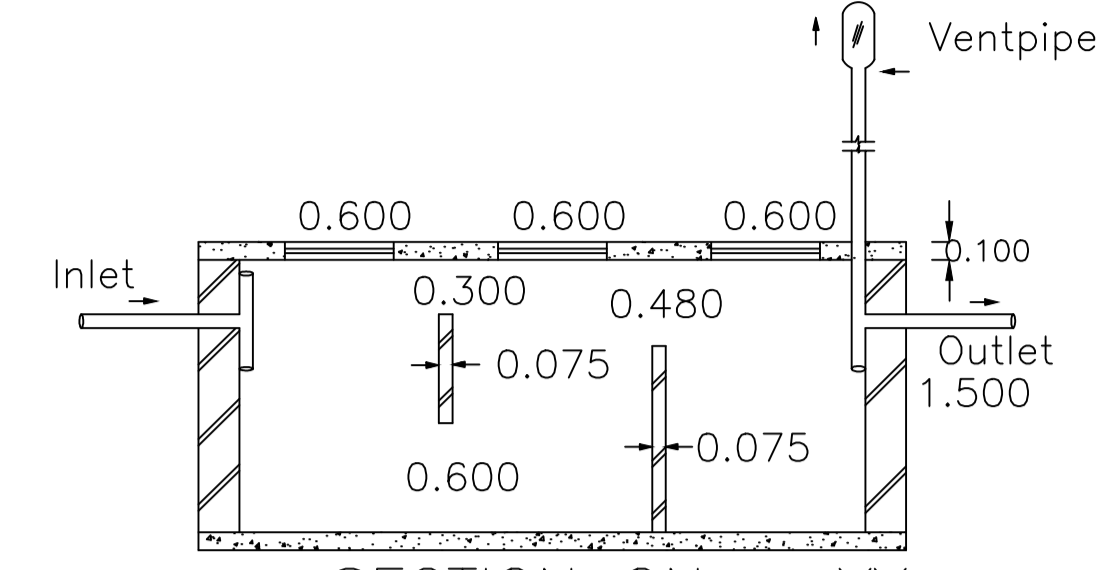

SECTION ON - YY

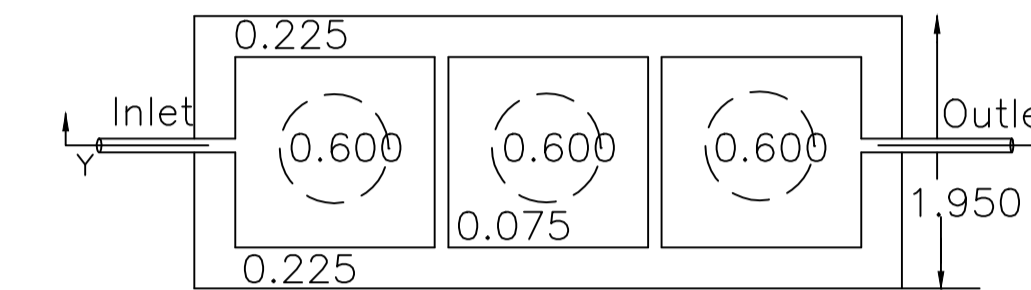

DETAILS OF SEPTIC TANK

SCALE = 1 : 2

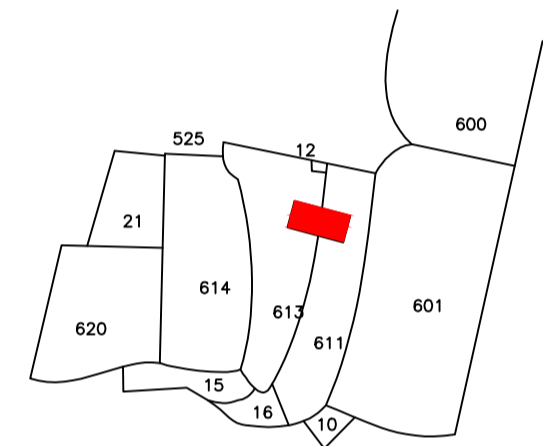

KEY PLAN
Not to scale

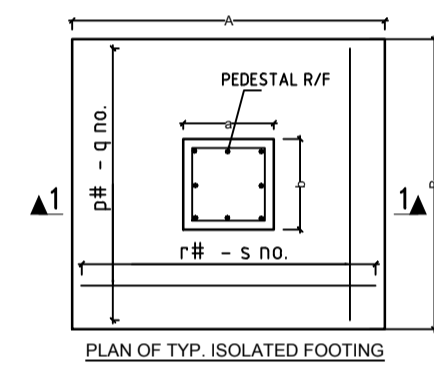

PLAN OF TYP. ISOLATED FOOTING

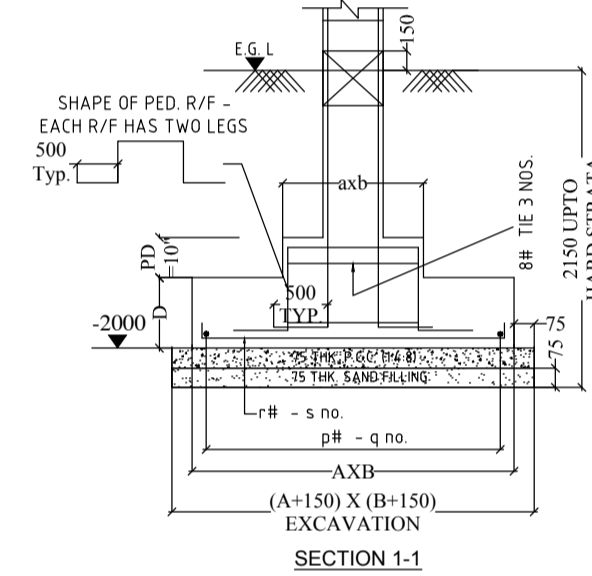

SECTION 1-1

DETAILS OF COLUMN FOOTING

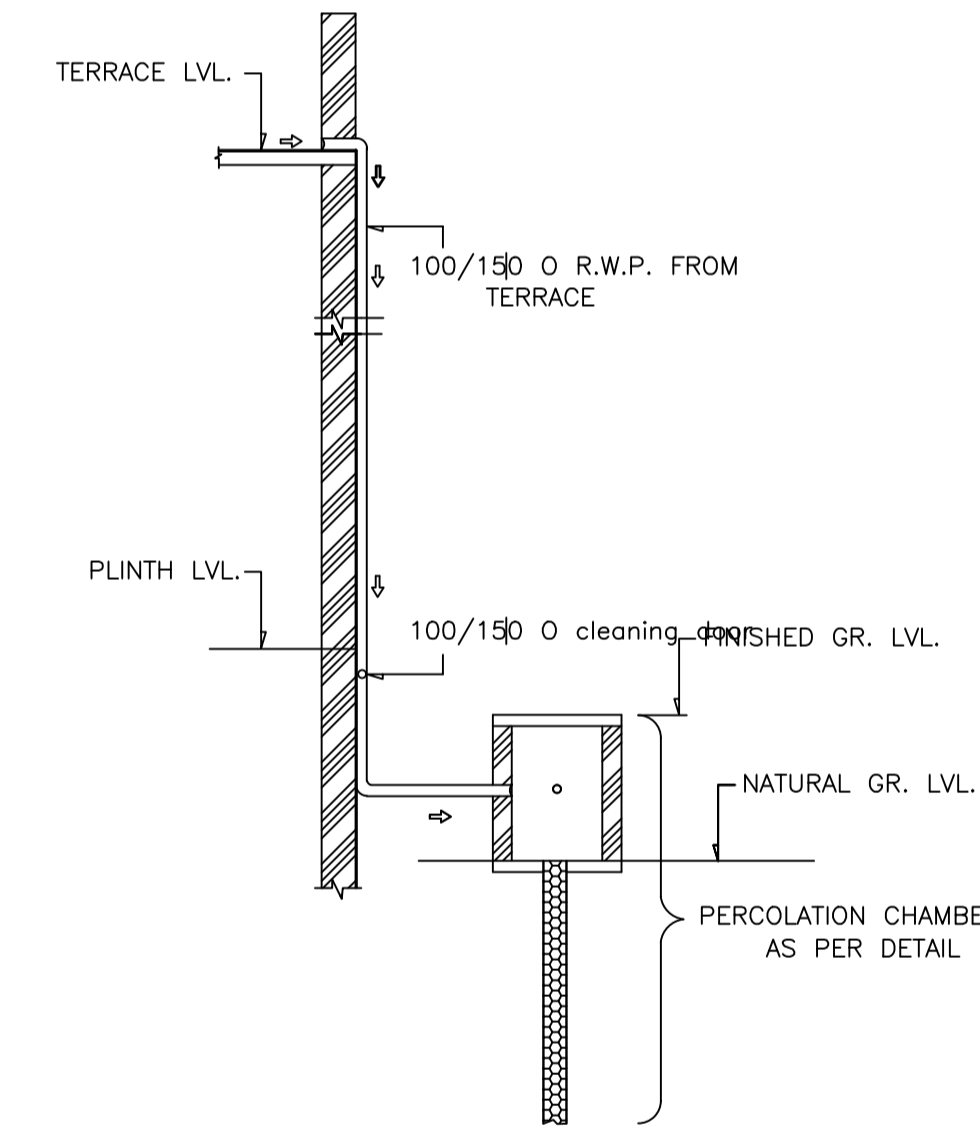

ROOF TOP RAIN WATER COLLECTION SYSTEM
SCALE = 1 : 2

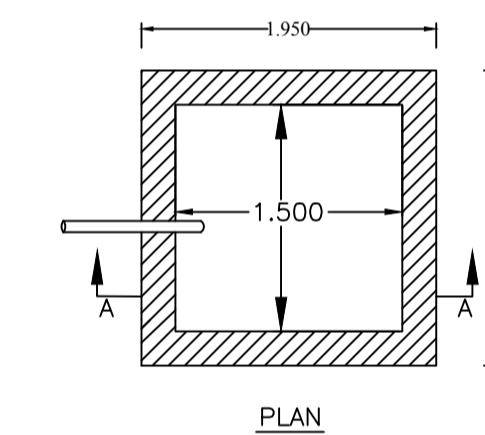

DETAILS OF WATER HARVESTING

SCALE = 1 : 2

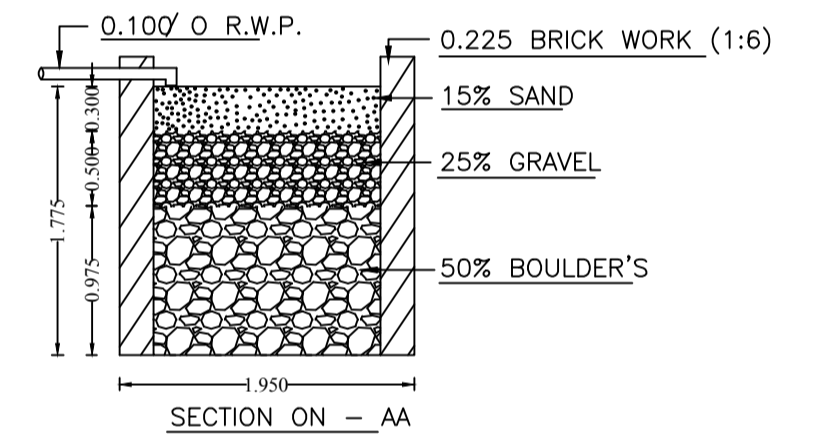

SECTION ON - AA

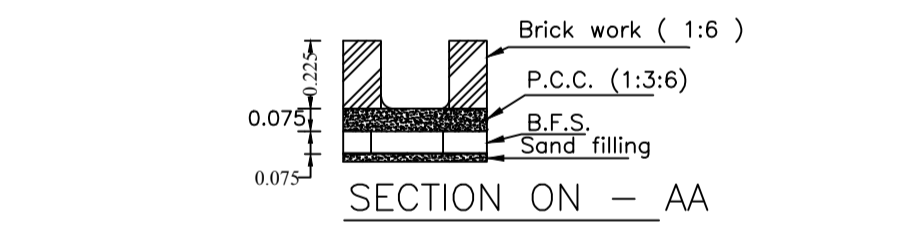

SECTION ON - AA

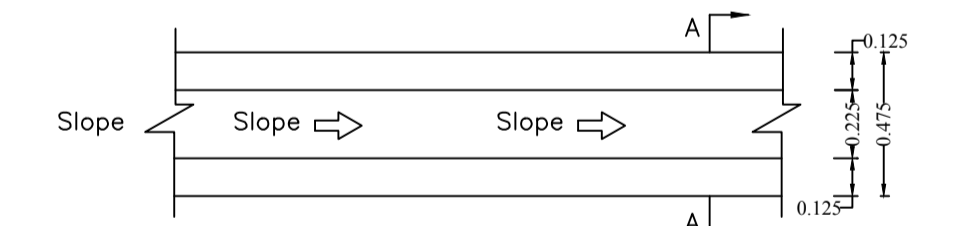

DETAILS OF MAIN DRAIN
SCALE = 1 : 4

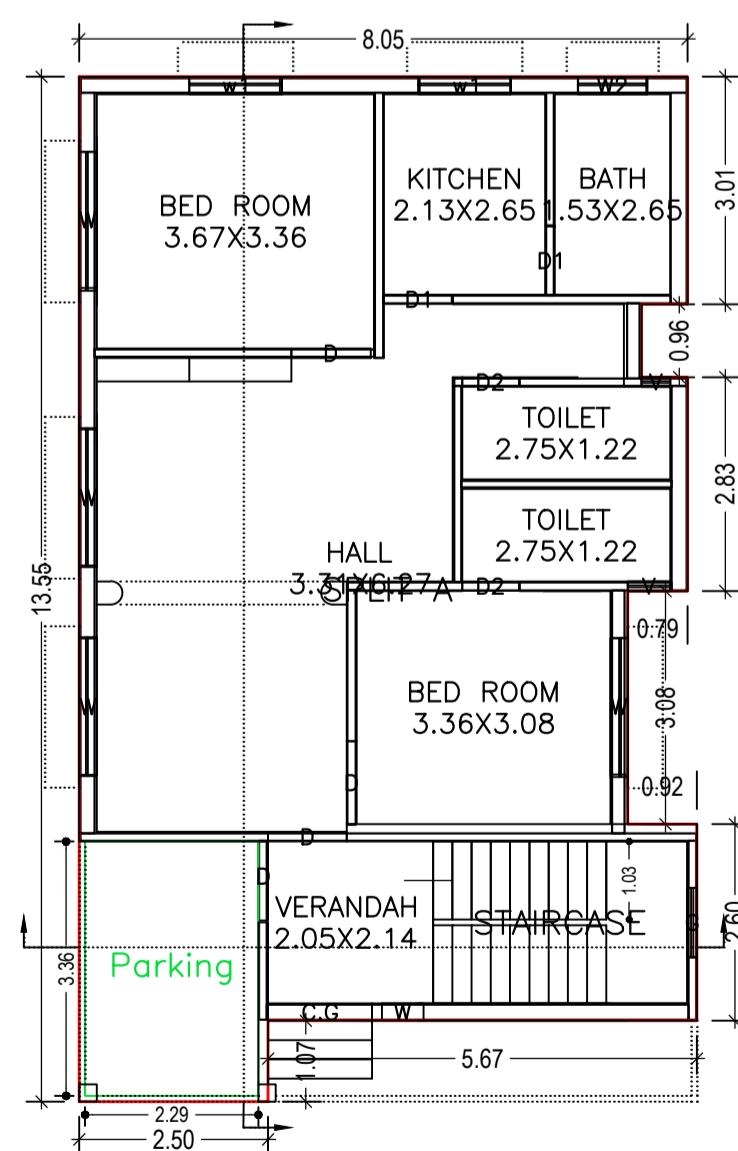

GROUND FLOOR PLAN
(Proposed)
(SCALE 1:100)

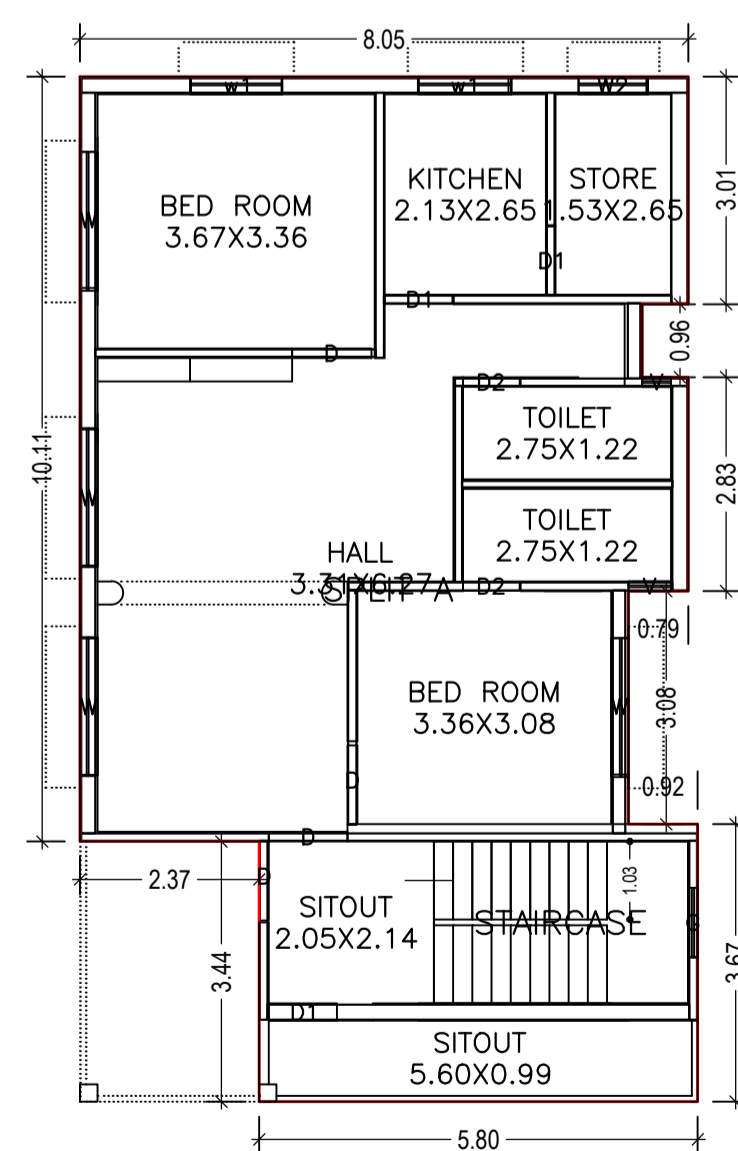

FIRST FLOOR PLAN
(Proposed)
(SCALE 1:100)

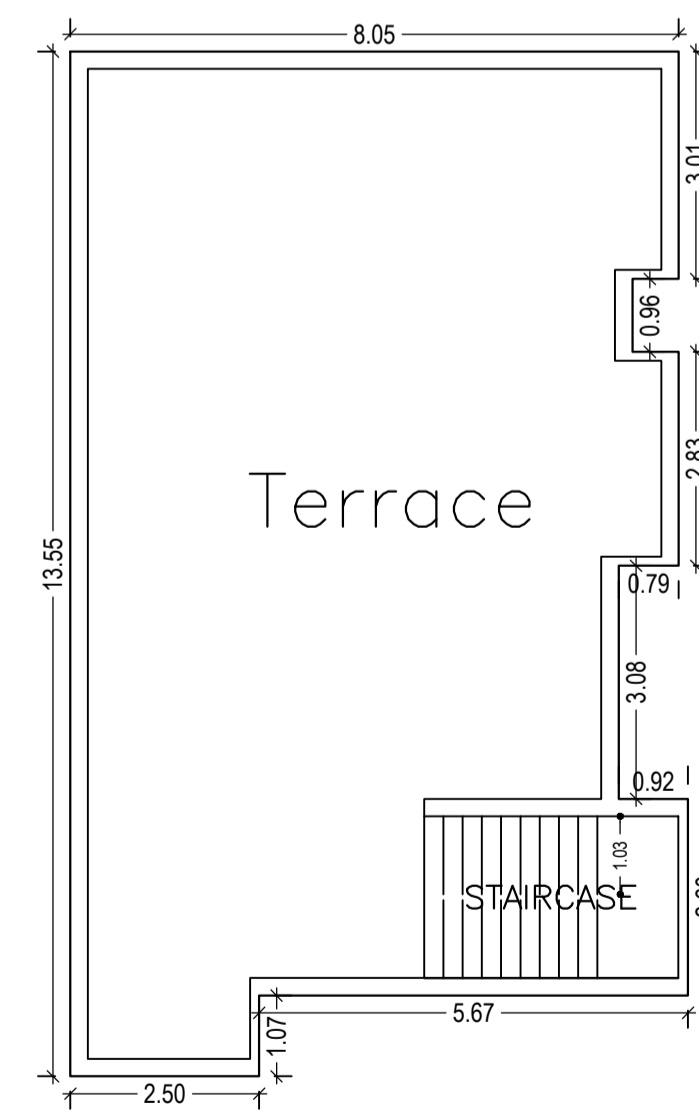

TERRACE FLOOR PLAN
(SCALE 1:100)

| LTP NAME AND SIGNATURE | STRUCTURAL ENG'S NAME AND SIGNATURE | BUILDER NAME AND SIGNATURE |
|--------------------------------------|-------------------------------------|----------------------------|
| AMARENDRA KUMAR DMC/ENG/0009/2016 | | |