

Proposal Basic Information

Proposal File No.	DMC/BP/0148/W23/2018
Owner Name	MISS SARASWATI MAHATO
Khata No	131
Plot No	3329
Village Name	Kolakusma
Use	Residential
SubUse	Bungalow/ Dwelling / Non Apartment

AREA STATEMENT

Version No.:	1.028	
Version Date:	30/06/2018	
PROJECT DETAIL:		
Region: JHARKHAND URBAN	Plot Use: Residential	
Local Bodies: DHANBAD	Plot SubUse: Bungalow/ Dwelling / Non Apartment	
Authority: DHANBAD MUNICIPAL CORPORATION	Plot/Nearby/Religious Structure: NA	
Inward No: DMC/BP/0148/W23/2018	Plot/SubPlot No: 3329	
Application Type: General Proposal	North: Survey No. - JANAK PRASAD SRIVASTAVA	
Project Type: Building Permission	South: Survey No. - PORTION OF THIS PLOT	
Nature of Development: New	East: Road Width - 3.65	
Location of Development Area: Old Area	West: Survey No. - PORTION OF THIS PLOT	
AREA DETAILS:		
AREA OF PLOT (Minimum)	(A)	333.24
NET AREA OF PLOT (Gross Plot Area - Deduction from Gross Plot area)	(A-Deductions)	333.24
Deduction for Balance Plot Area (from Gross Plot Area)		
Common Plot		74.71
Total		74.71
BALANCE AREA OF PLOT (Net Plot Area - Recreational/Amenity space)	(A-Deductions)	258.53
PLOT AREA FOR COVERAGE (Net Plot Area)	(A-Deductions)	333.24
Plot Area for FAR (Net Plot Area + Road Widening Area)	(A-Deductions)	333.24
COVERAGE CHECK		
Permissible Coverage area (60.00 %)		199.94
Proposed Coverage Area (57.08 %)		190.22
Total Prop. Coverage Area (57.08 %)		190.22
Balance coverage area (2.92 %)		9.72
FAR CHECK		
Perm. FAR Area (1.50)		499.86
Maximum Permissible FAR Area (2.50)		833.10
Total Perm. FAR area		833.10
Residential FAR		570.66
Proposed FAR Area		570.66
Total Proposed FAR Area		570.66
Consumed FAR (Factor)		1.71
Balance FAR Area		262.44
Total Paid Proposed FAR Area		70.80
BUILT UP AREA CHECK		
Total Proposed BuiltUp Area		570.66
ARCHITECT (Regd)		PARTHA - PAL
ENGINEER (Regd)		
SUPERVISOR (Regd)		
OWNER (Regd)		MISS SARASWATI MAHATO
DEVELOPMENT AUTHORITY		LOCAL BODY



UnitBUA Table for Building :A (BUILDING)

FLOOR	Name	UnitBUA Type	UnitBUA Area	Carpet Area	No. of Rooms	No. of Tenement
GROUND FLOOR PLAN	SPLIT FLAT - A	FLAT	534.98	472.25	5	1
TYPICAL - 1, 2 FLOOR PLAN	SPLIT FLAT - A	FLAT	0.00	0.00	13	0
Total:			534.98	472.25	31	1

Buildingwise Floor FAR Details

Floor Name	Building Name A (BUILDING)		Total			
	Proposed Built Up Area (Sq.mt.)	Proposed FAR Area (Sq.mt.)	Total Proposed Built Up Area (Sq.mt.)	Total FAR Area (Sq.mt.)	Total Maximum Permissible FAR Area (Sq.mt.)	Total Paid Built Up Area (Sq.mt.)
Ground Floor	190.22	190.22	190.22	190.22	70.80	70.80
First Floor	190.22	190.22	190.22	190.22	0.00	0.00
Second Floor	190.22	190.22	190.22	190.22	0.00	0.00
Terrace Floor	0.00	0.00	0.00	0.00	0.00	0.00
Total :	570.66	570.66	570.66	570.66	70.80	70.80

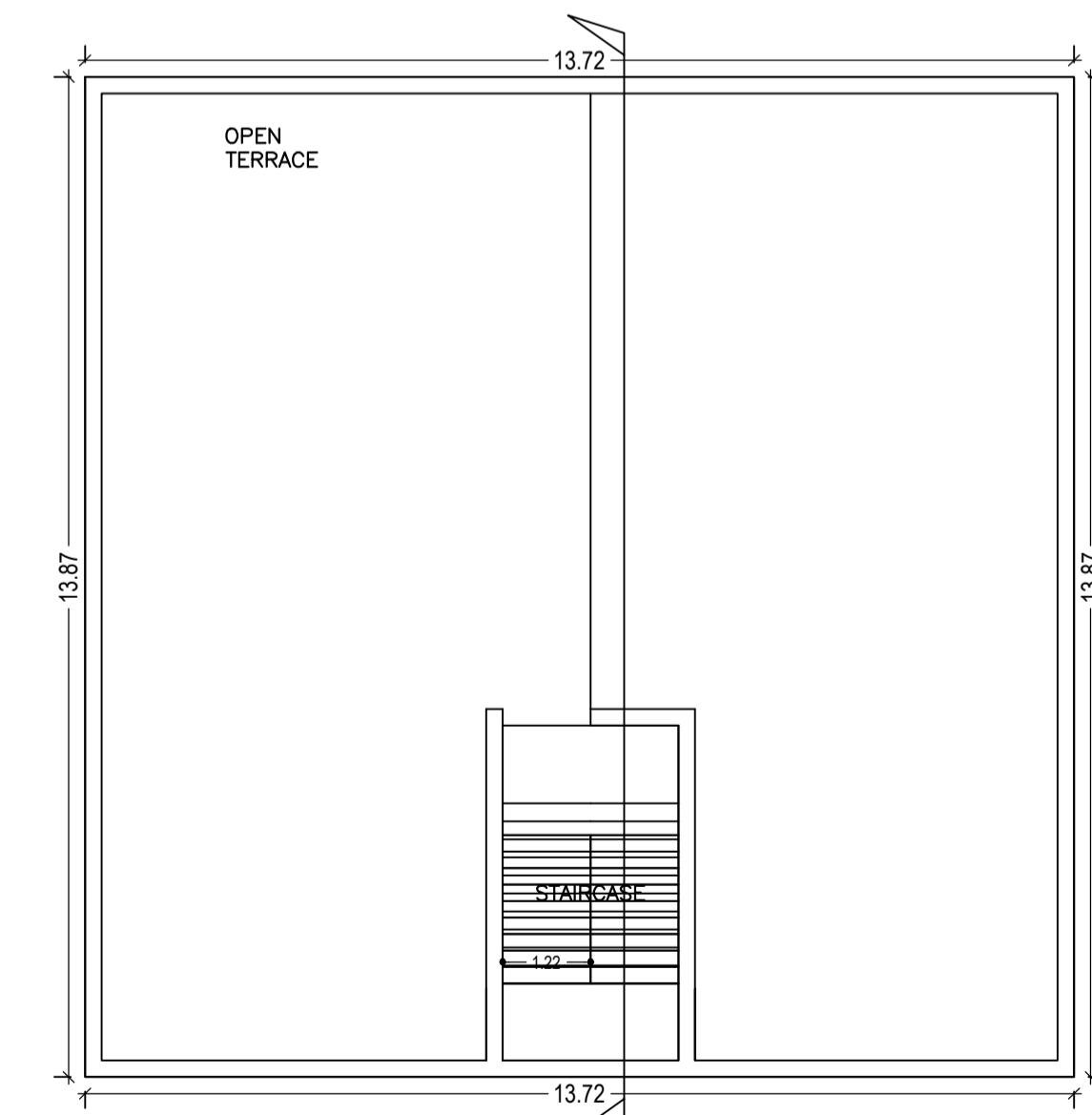
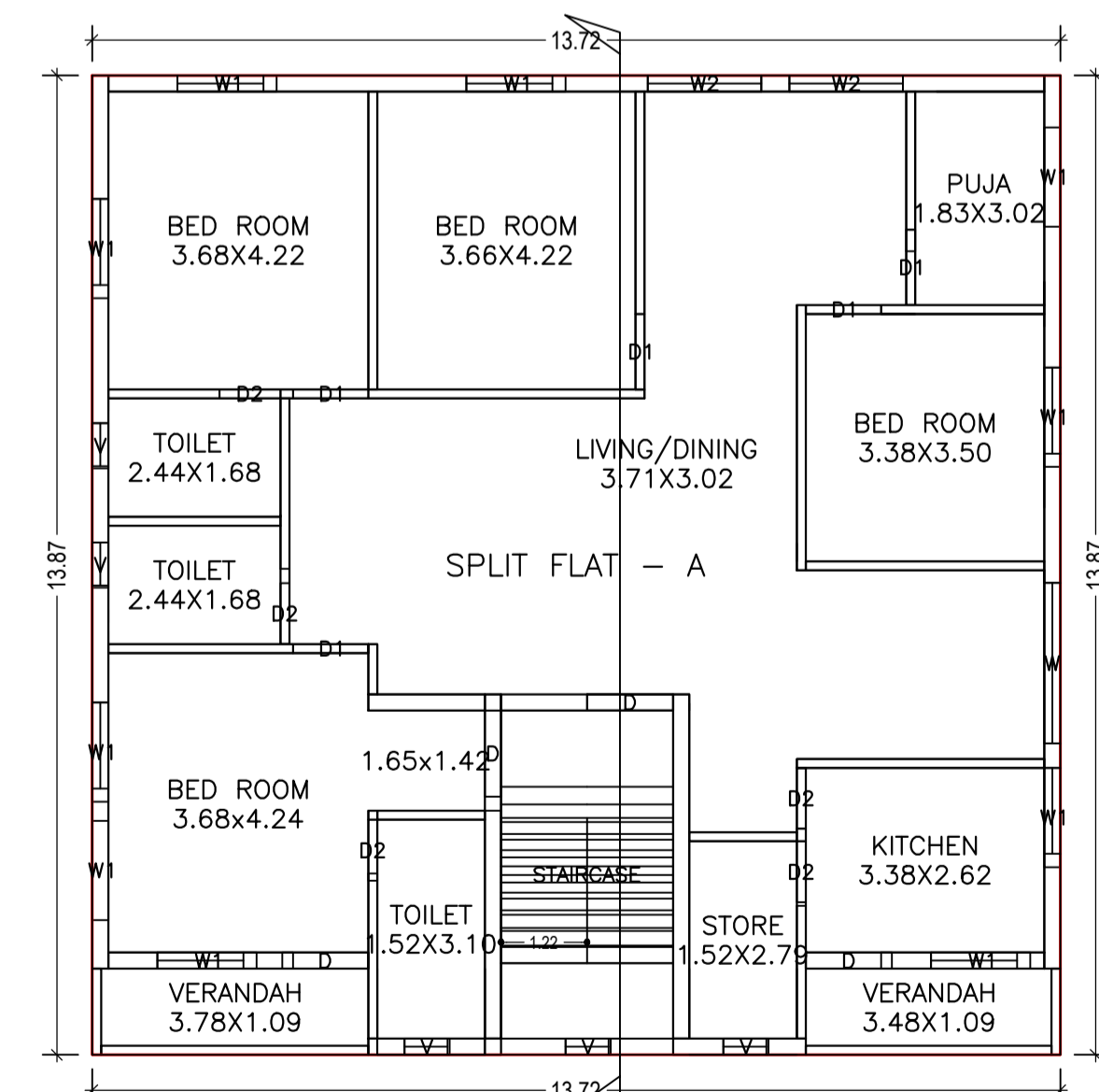
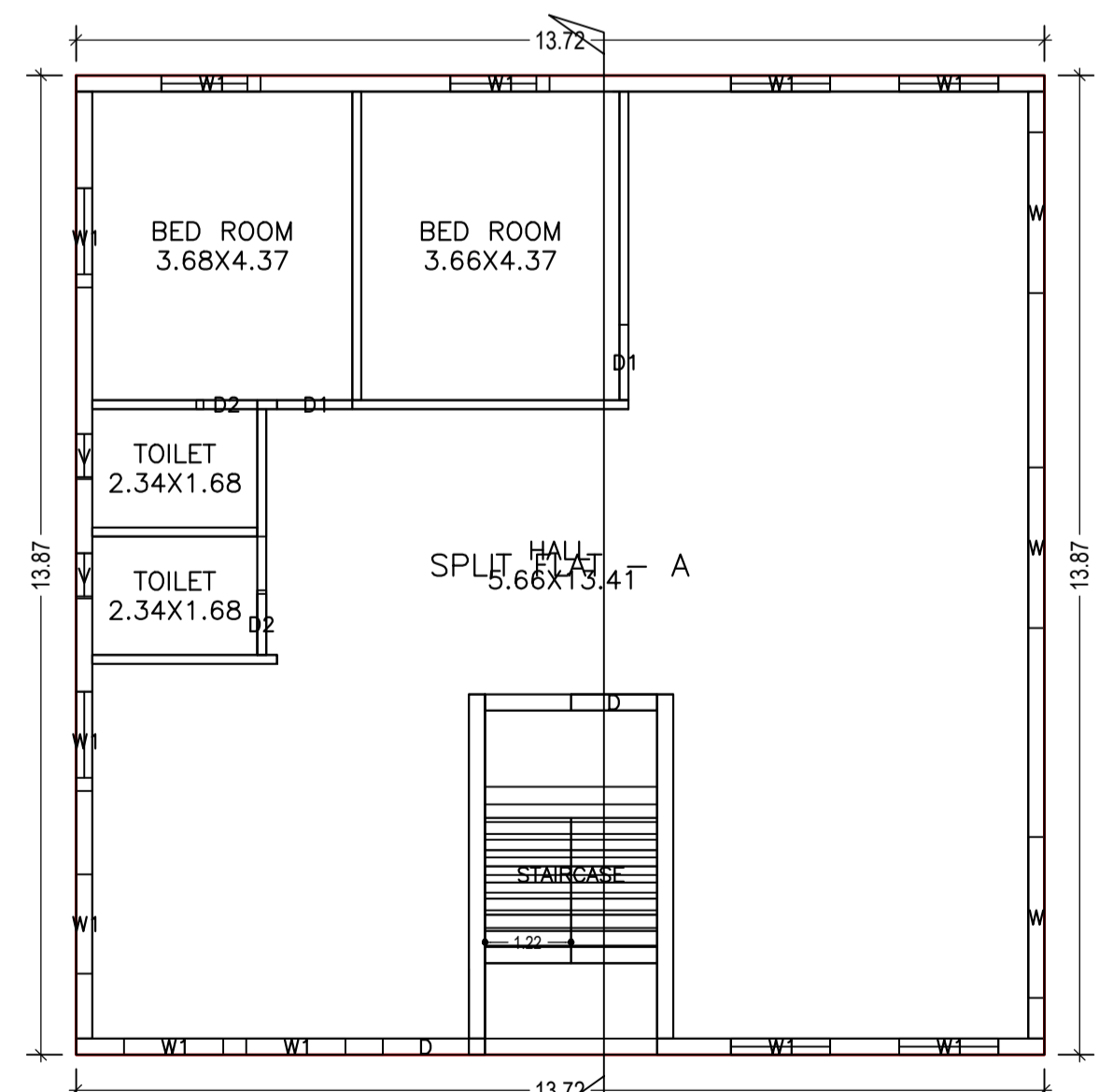

FAR & Tenement Details (Table 4c-1)

Building	No. of Same Bldg	Total Built Up Area (Sq.mt.)	Proposed FAR Area (Sq.mt.) Resi.	Total FAR Area (Sq.mt.)	Total Consumed Additional FAR Area (Sq.mt.)	Tnmt (No.)
A (BUILDING)	1	570.66	570.66	570.66	570.66	01
Grand Total :	1	570.66	570.66	570.66	570.66	01

Building USE/SUBUSE Details

Building Name	Building Use	Building SubUse	Building Structure
A (BUILDING)	Residential	Residential Bldg/Apartment	Non-Highrise

COLOR INDEX

PLOT BOUNDARY	Black
ABUTTING ROAD	Red
PROPOSED CONSTRUCTION	Green
COMMON PLOT	Yellow
ROAD WIDENING AREA	Blue
EXISTING (To be retained)	Orange
EXISTING (To be demolished)	Light Blue

SCHEDULE OF DOOR:

BUILDING NAME	NAME	LENGTH	HEIGHT	NOS
A (BUILDING)	D2	0.86	2.10	12
A (BUILDING)	D1	1.07	2.10	12
A (BUILDING)	D	1.22	2.10	10

SCHEDULE OF WINDOW/VENTILATION:

BUILDING NAME	NAME	LENGTH	HEIGHT	NOS
A (BUILDING)	V	0.64	1.20	12
A (BUILDING)	W1	1.41	1.20	31
A (BUILDING)	W2	1.61	1.20	04
A (BUILDING)	W	2.28	1.20	05

Building :A (BUILDING)

Floor Name	Total Built Up Area (Sq.mt.)	Proposed FAR Area (Sq.mt.) Resi.	Total FAR Area (Sq.mt.)	Total Consumed Additional FAR Area (Sq.mt.)	Tnmt (No.)
Ground Floor	190.22	190.22	190.22	190.22	01
First Floor	190.22	190.22	190.22	190.22	00
Second Floor	190.22	190.22	190.22	190.22	00
Terrace Floor	0.00	0.00	0.00	0.00	00
Total :	570.66	570.66	570.66	570.66	01
Total Number of Same Buildings :	1	570.66	570.66	570.66	01

LTP NAME AND SIGNATURE	STRUCTURAL ENG'S NAME AND SIGNATURE	BUILDER NAME AND SIGNATURE
PARTHA - PAL DMC/ENG/0021/2016		

Proposal Basic Information	
Proposal File No.	DMC/BP/0148/W23/2018
Owner Name	MISS SARASWATI MAHATO
Khata No	131
Plot No	3329
Village Name	Kolakusma
Use	Residential
SubUse	Bungalow/ Dwelling / Non Apartment

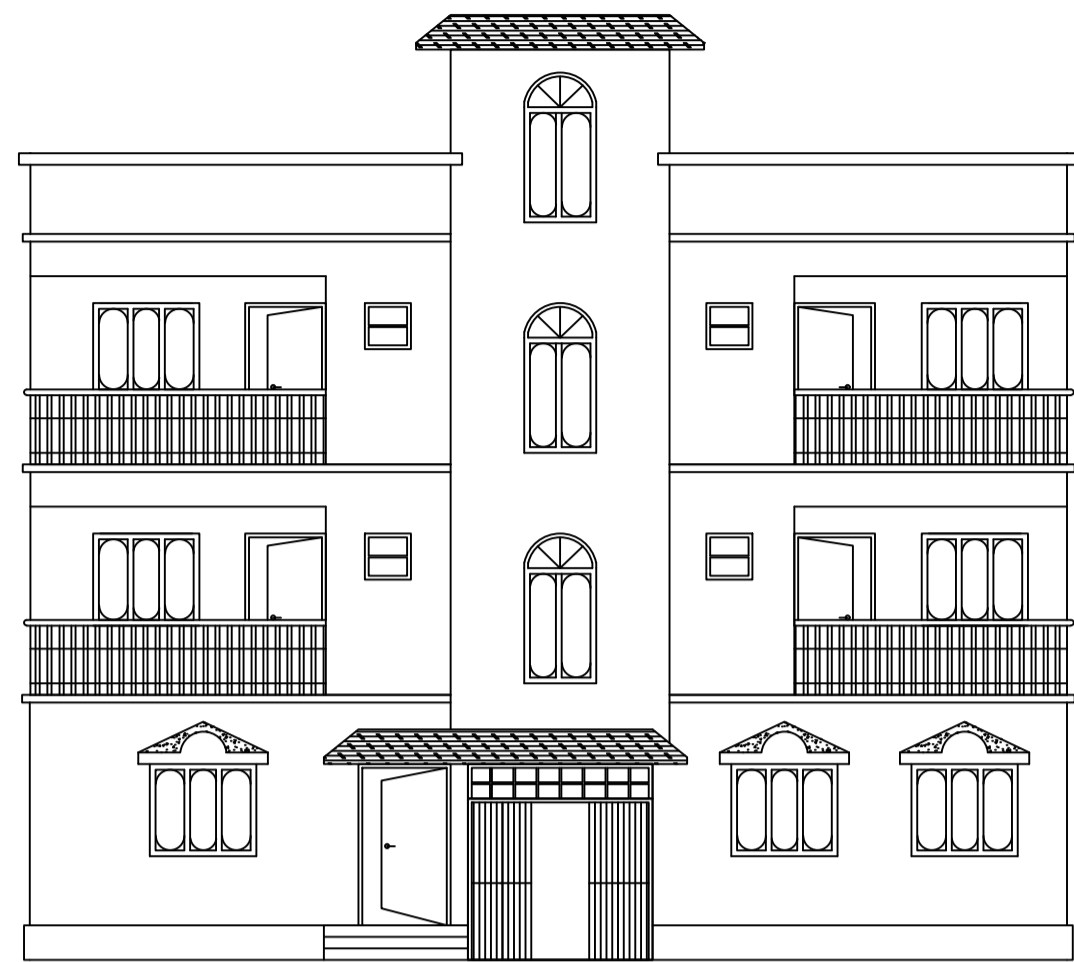

FRONT ELEVATION

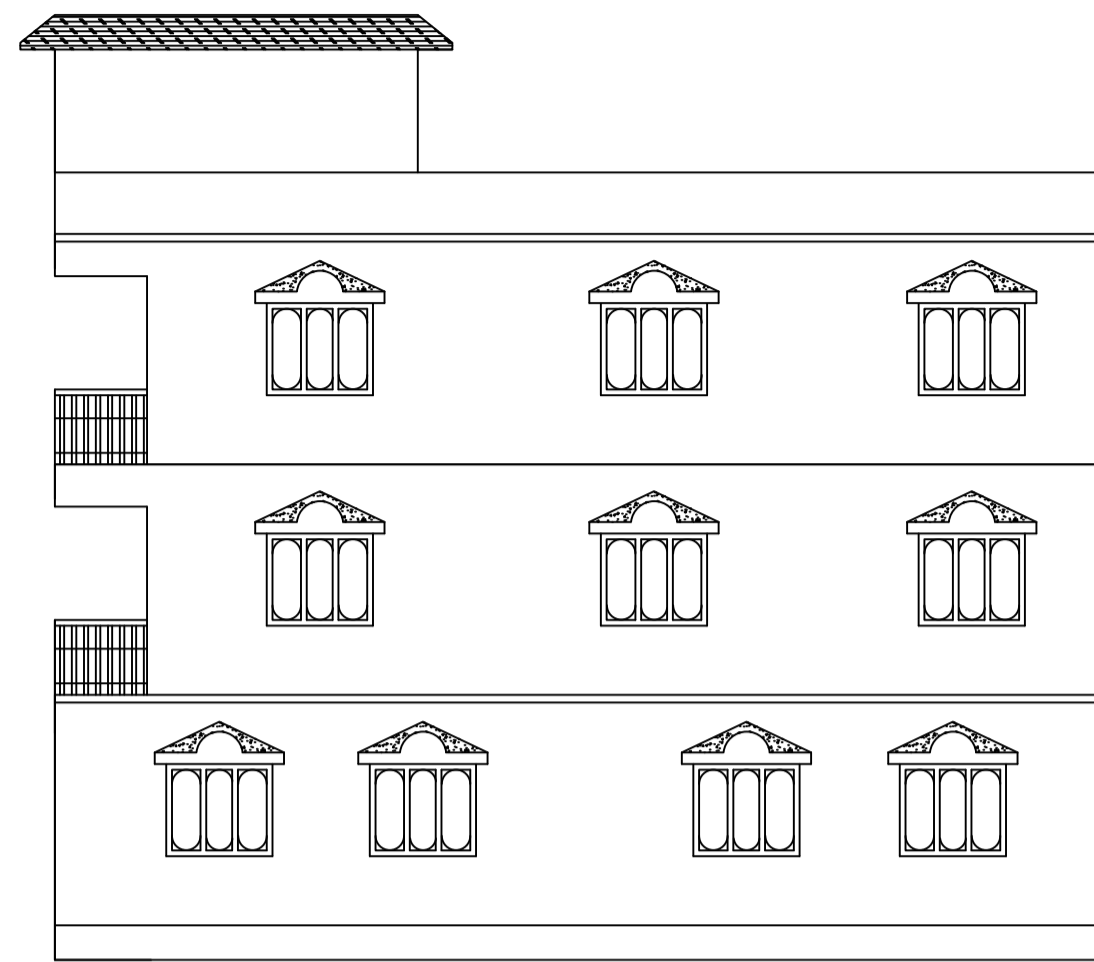

RIGHT SIDE ELEVATION

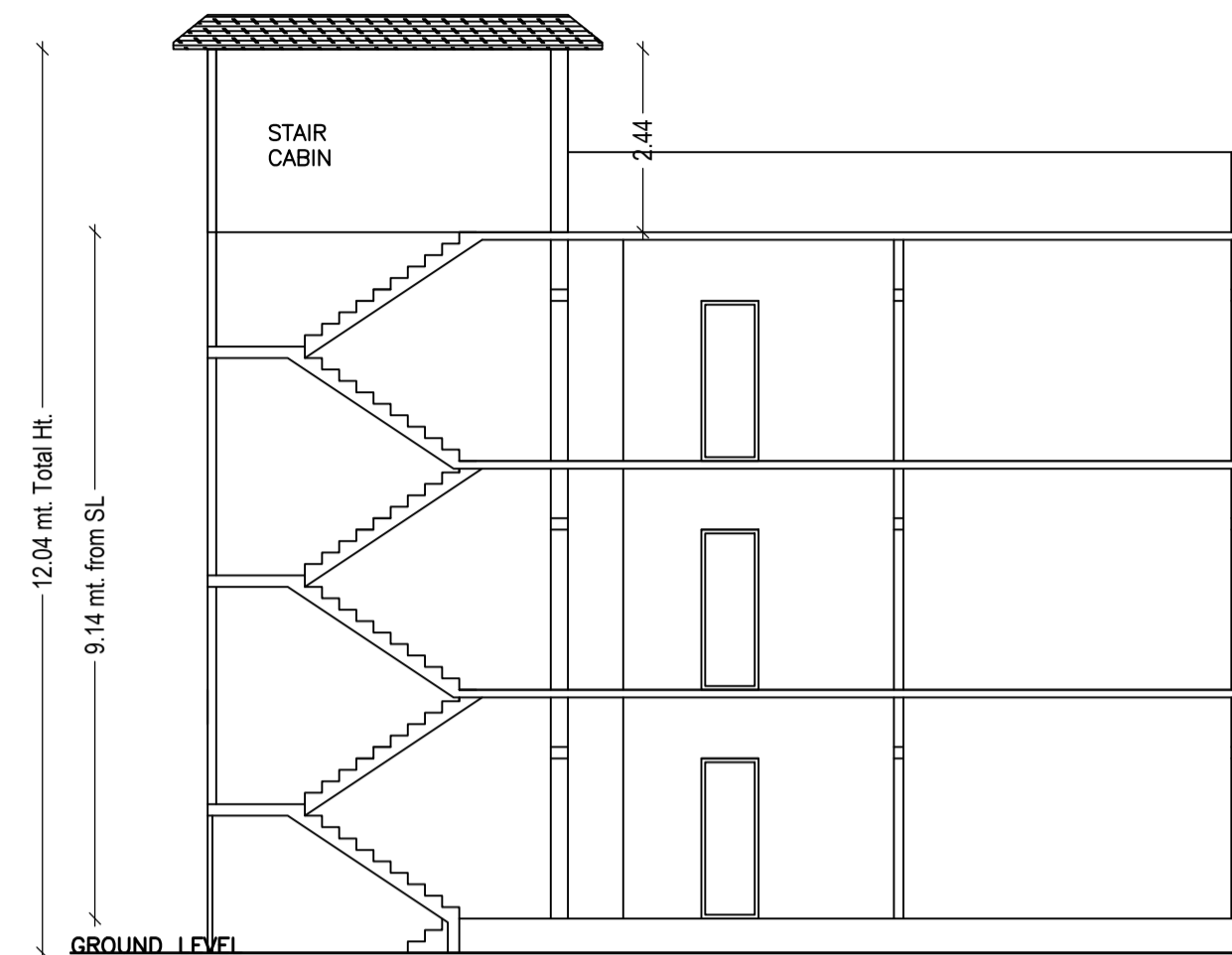

SECTION : Y-Y

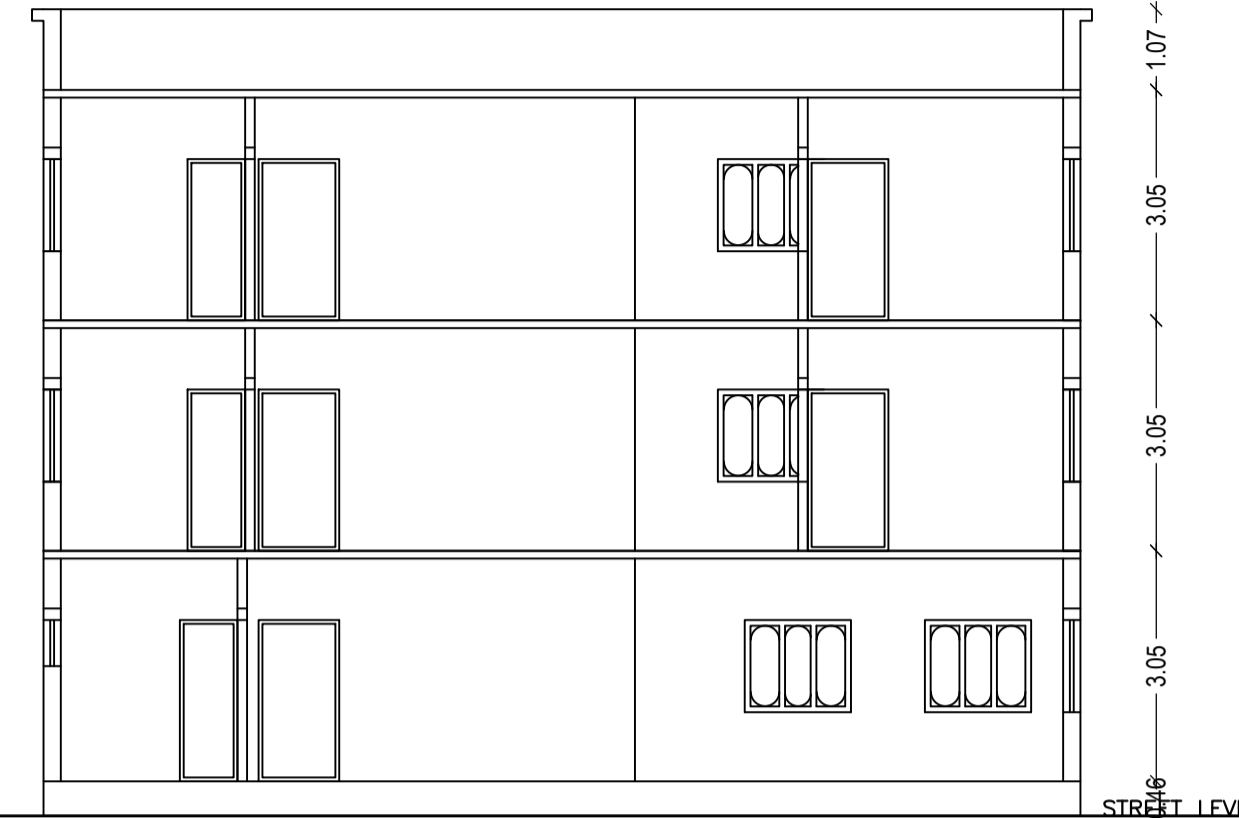

SECTION : X-X

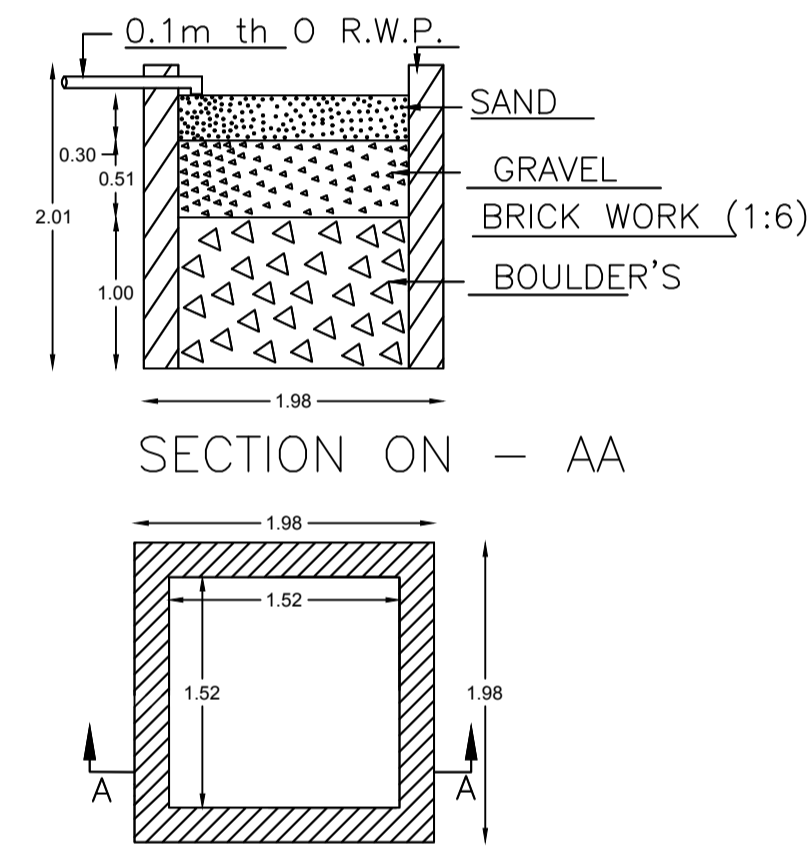
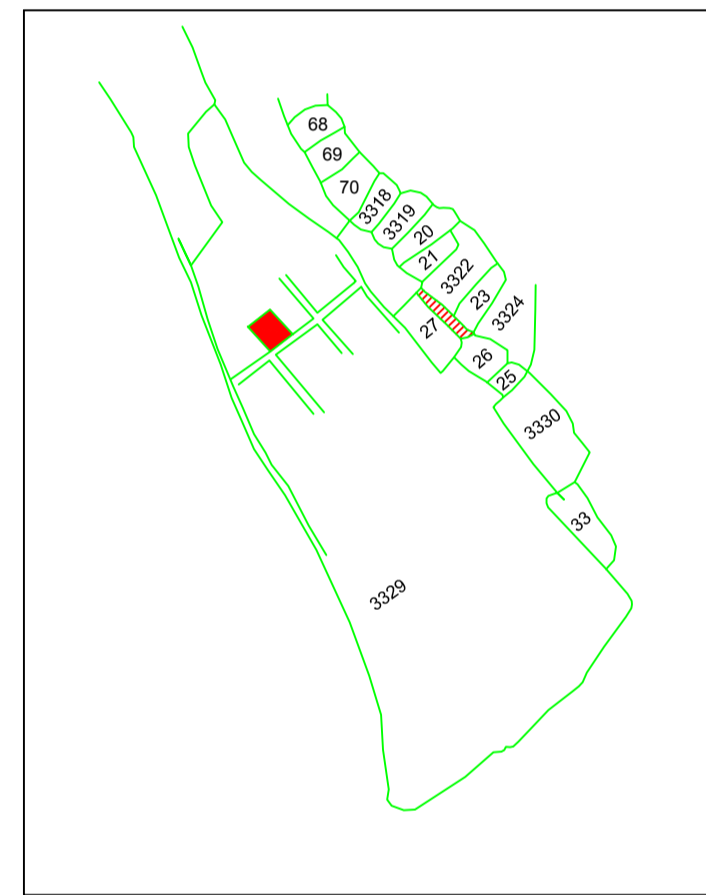

DETAIL'S OF WATER HARVESTING

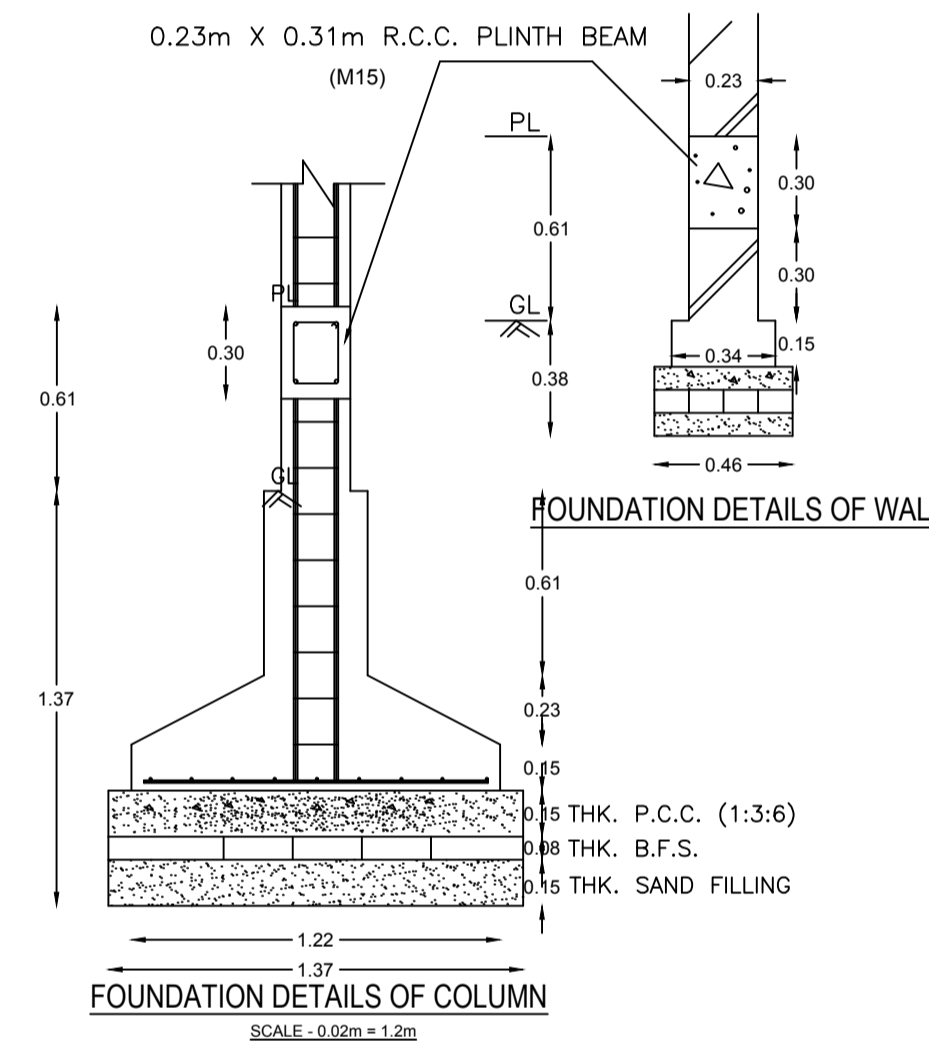

FOUNDATION DETAILS OF COLUMN

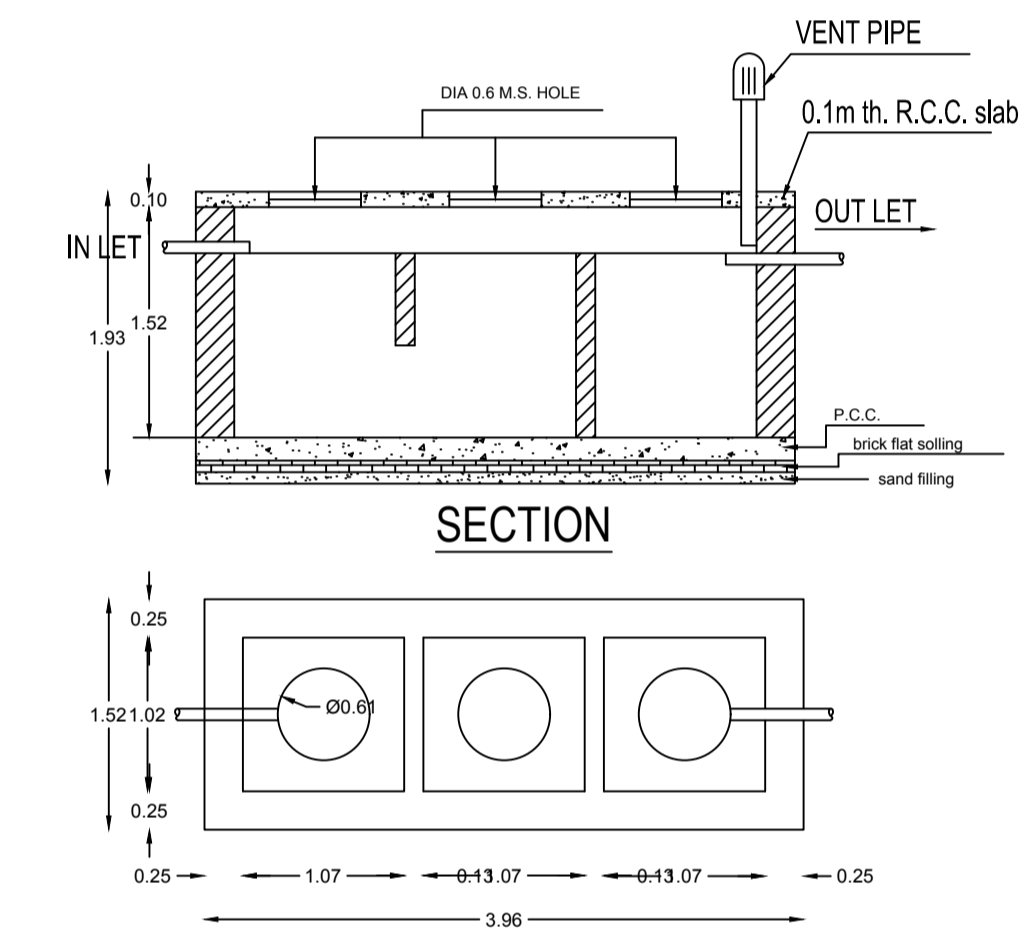

DETAILS OF SEPTIC TANK

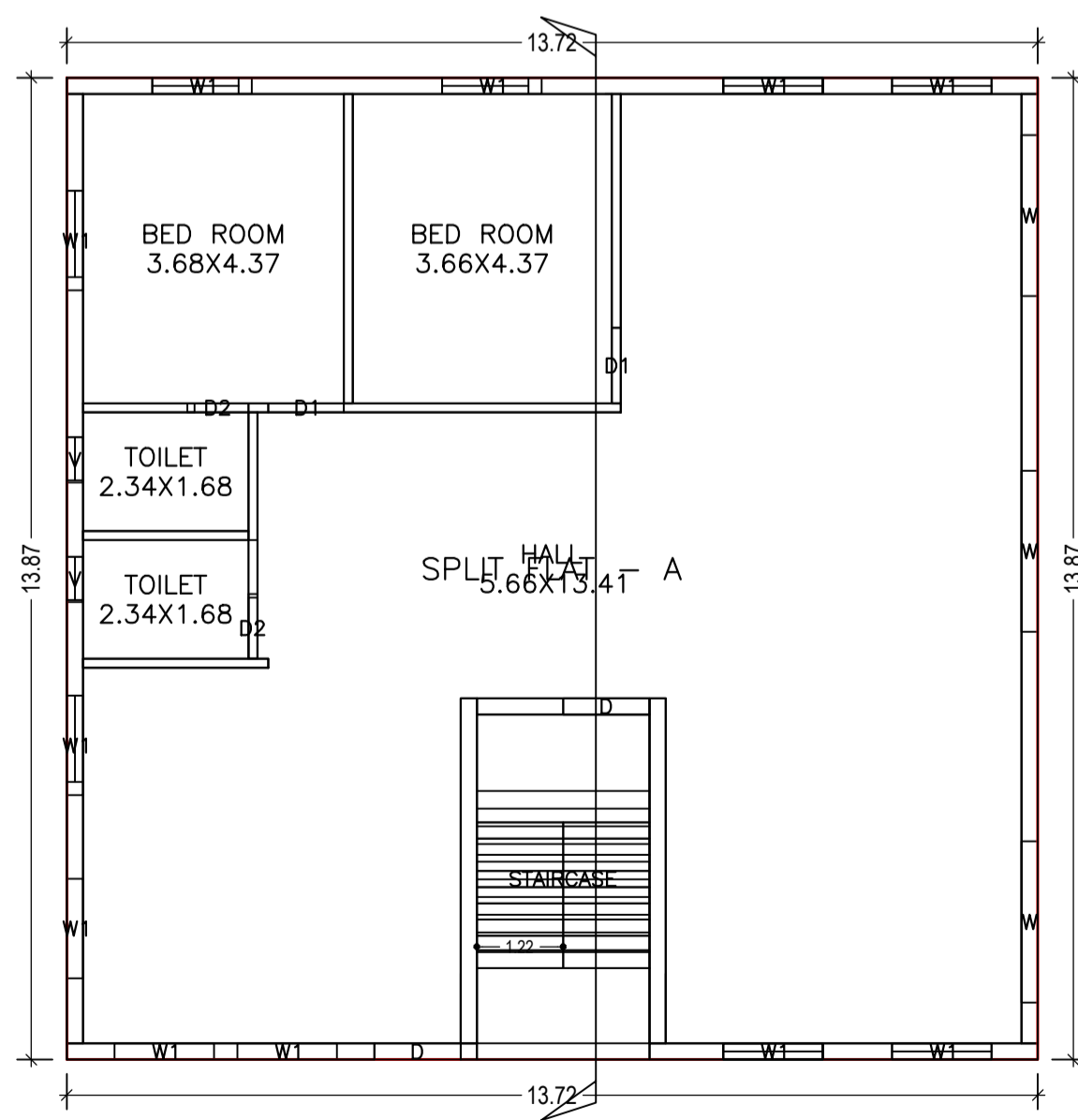

GROUND FLOOR PLAN
(Proposed)
(SCALE 1:100)

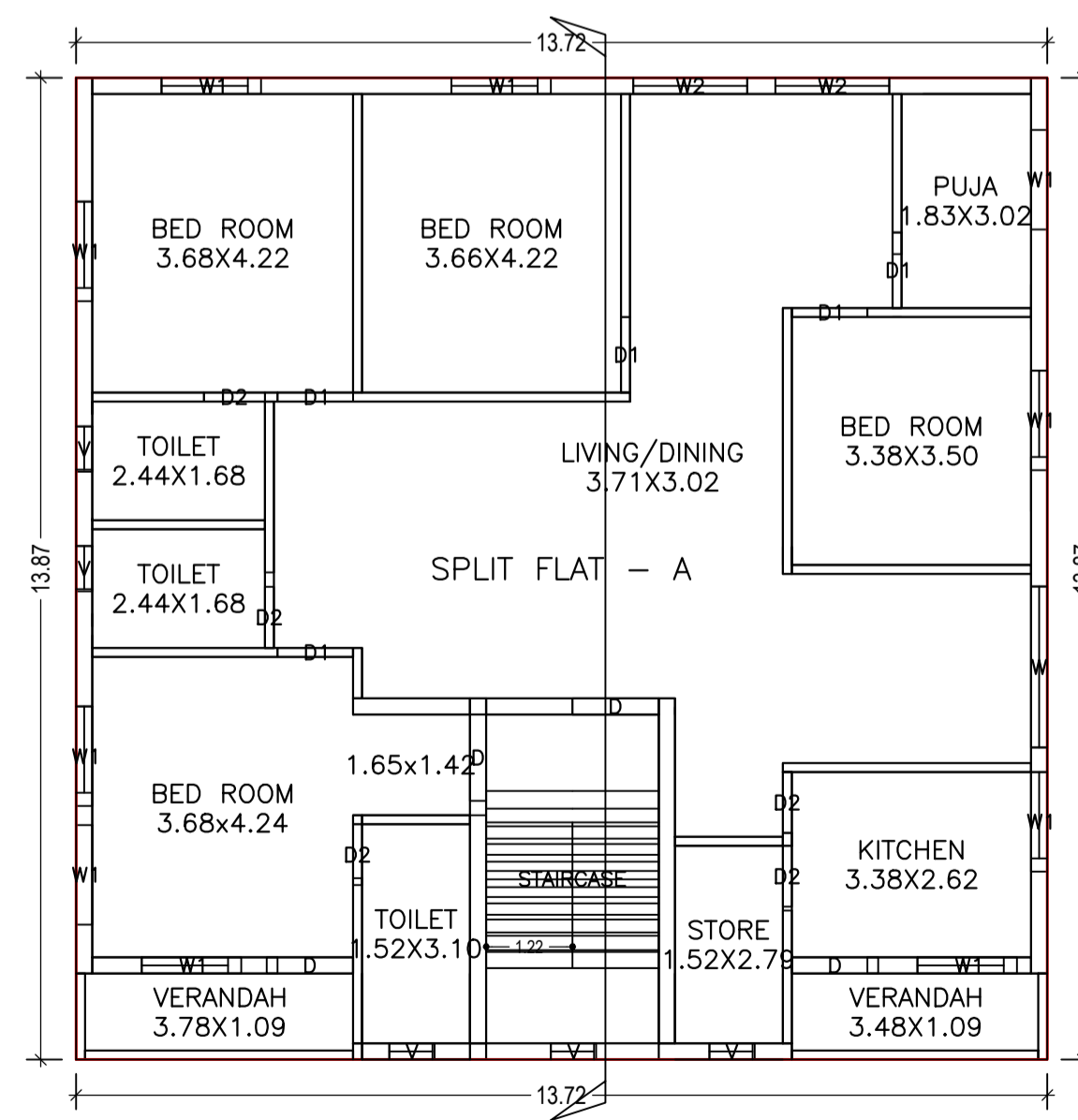

TYPICAL - 1,2 FLOOR PLAN
(Proposed)
(SCALE 1:100)

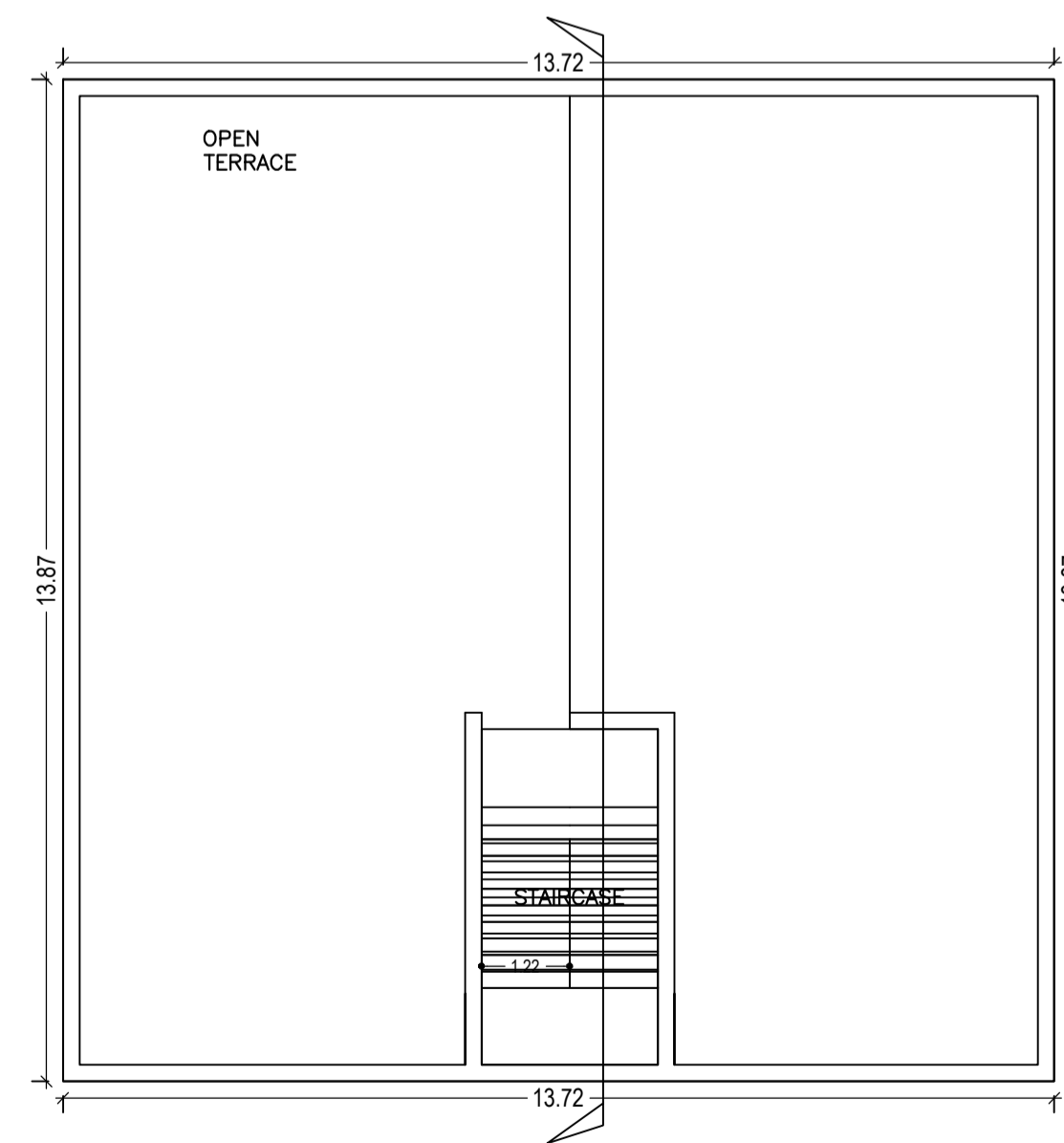

TERRACE FLOOR PLAN
(SCALE 1:100)

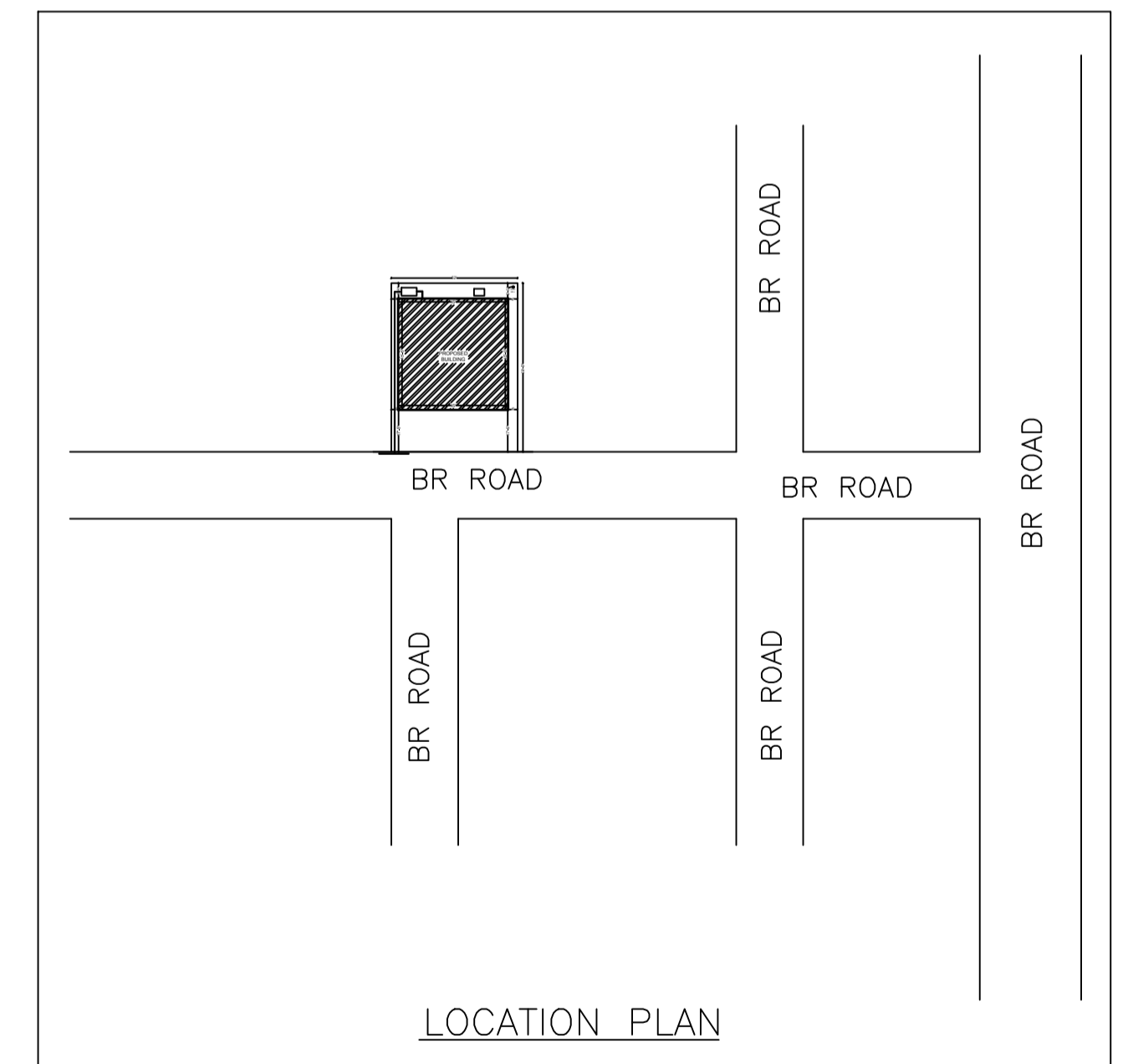

LOCATION PLAN

LTP NAME AND SIGNATURE	STRUCTURAL ENG'S NAME AND SIGNATURE	BUILDER NAME AND SIGNATURE
PARTHA - PAL DMC/ENG/00212016		