

SITE PLAN

SITE PLAN

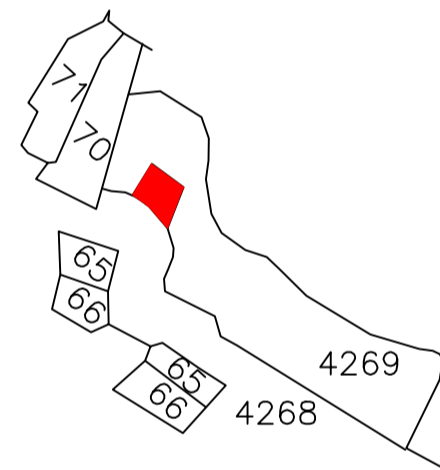

KEY PLAN

NOT TO SCALE

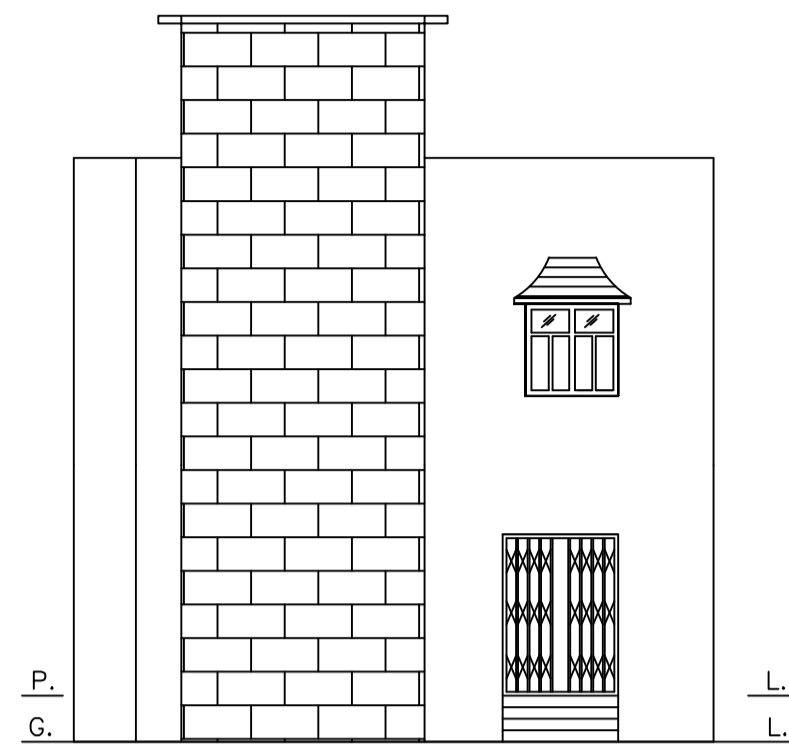

FRONT ELEVATION

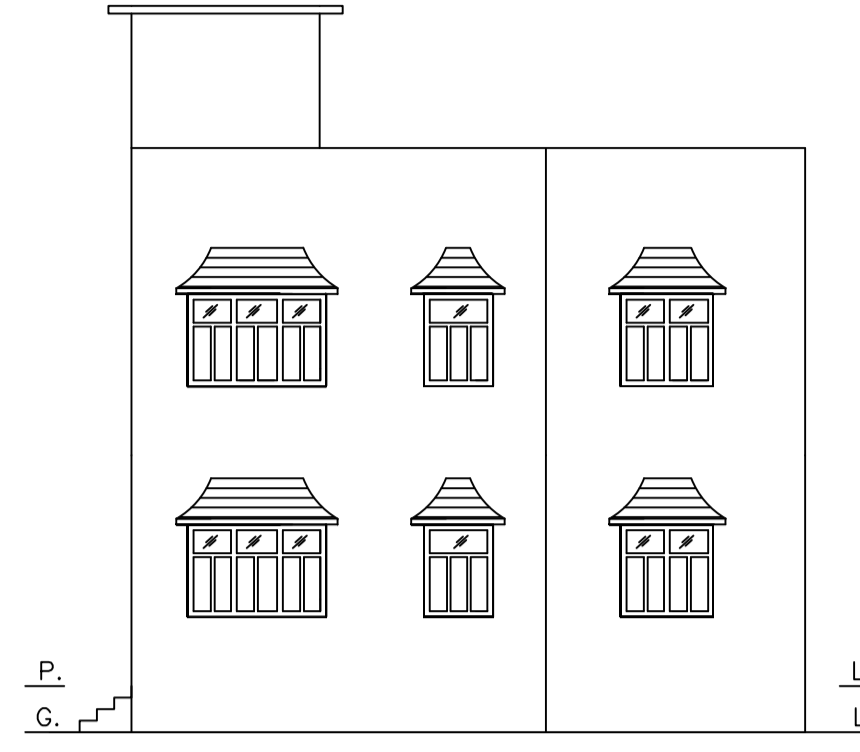

RIGHT SIDE ELEVATION

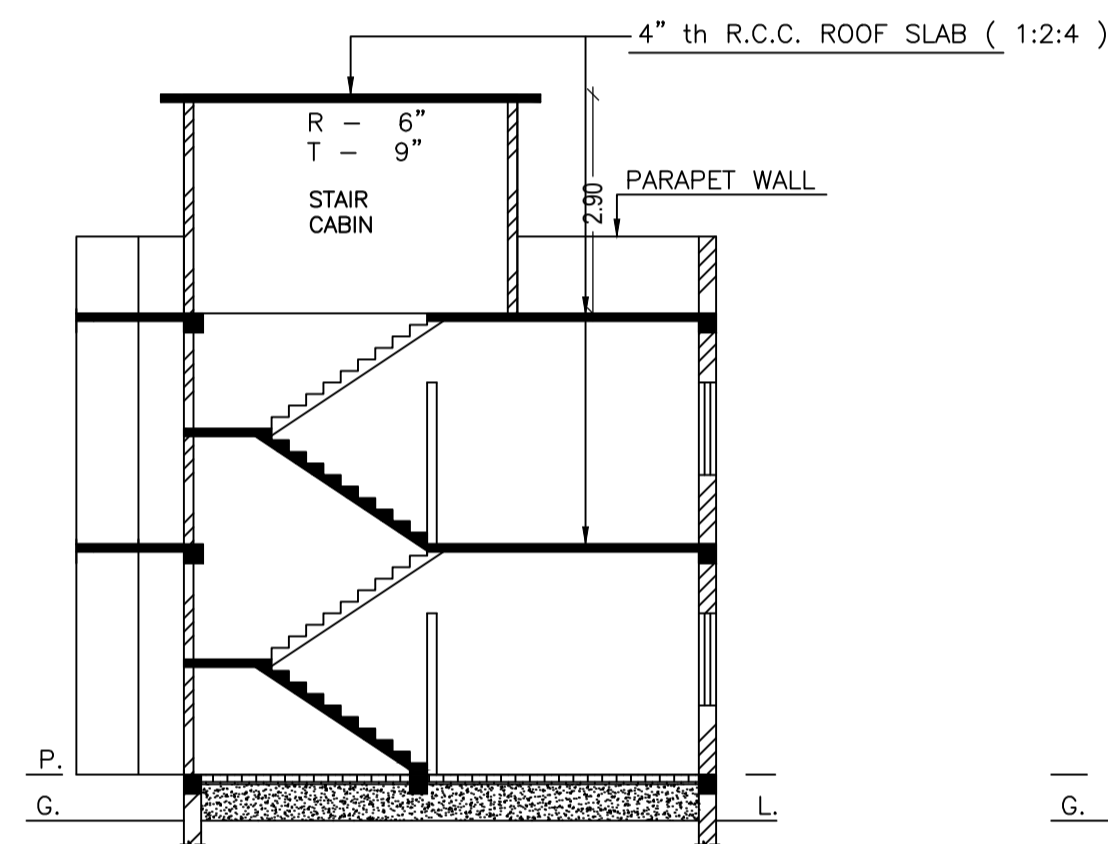

SECTION ON - XX

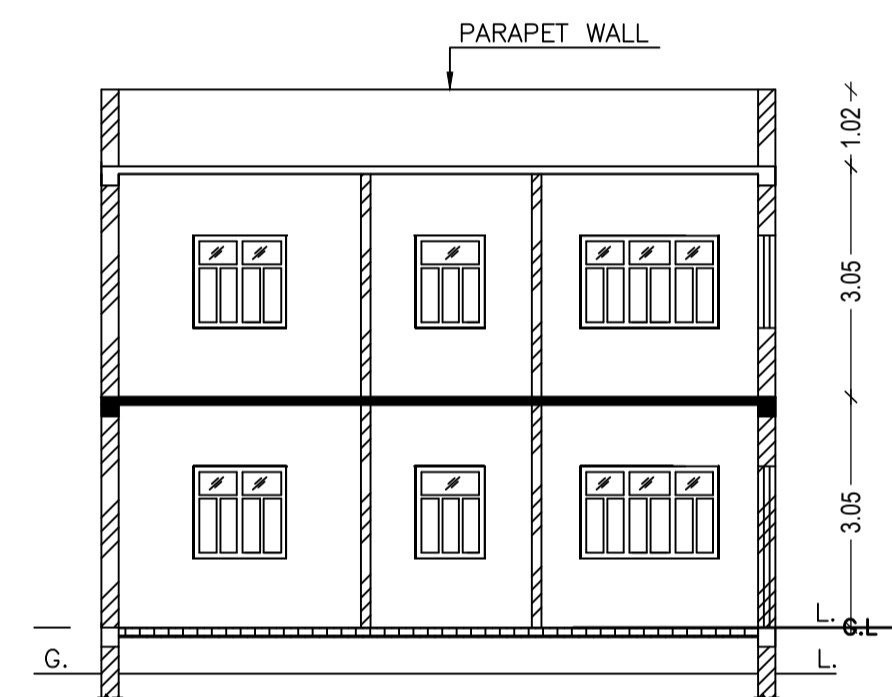

SECTION ON - YY

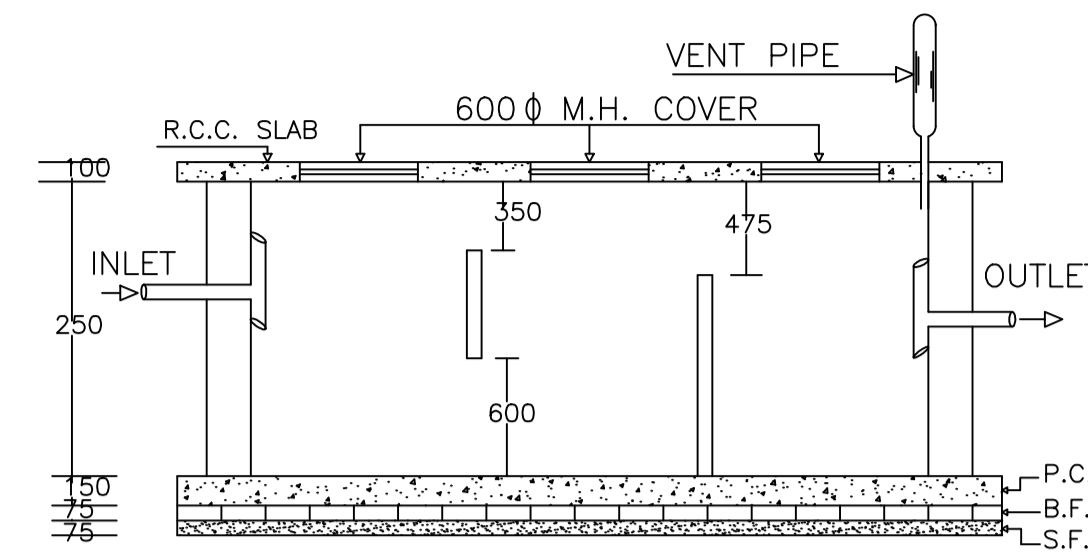

PLAN OF SEPTIC TANK

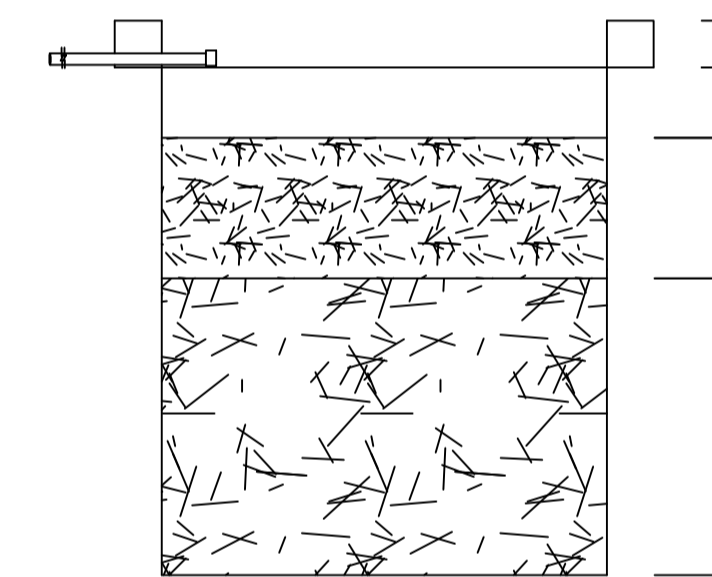

SECTION AT Y-Y

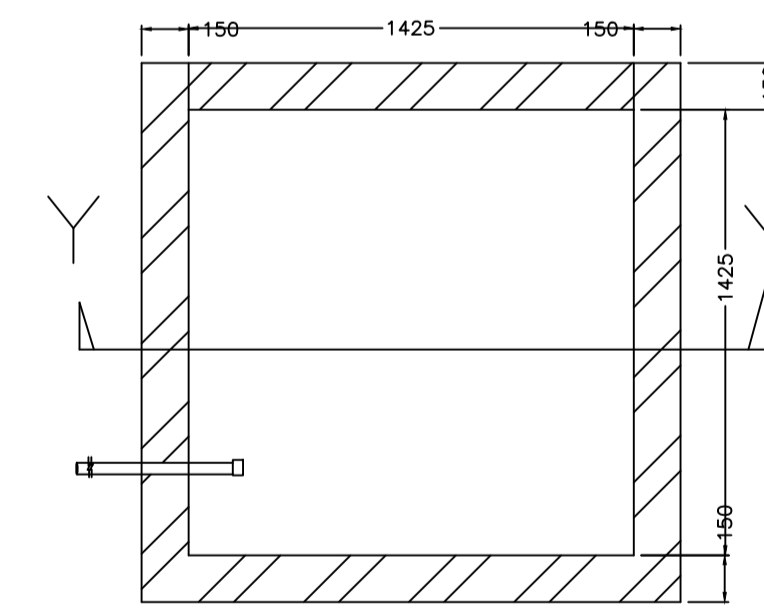

PLAN OF RECHARGE WELL

WATER HARVESTING

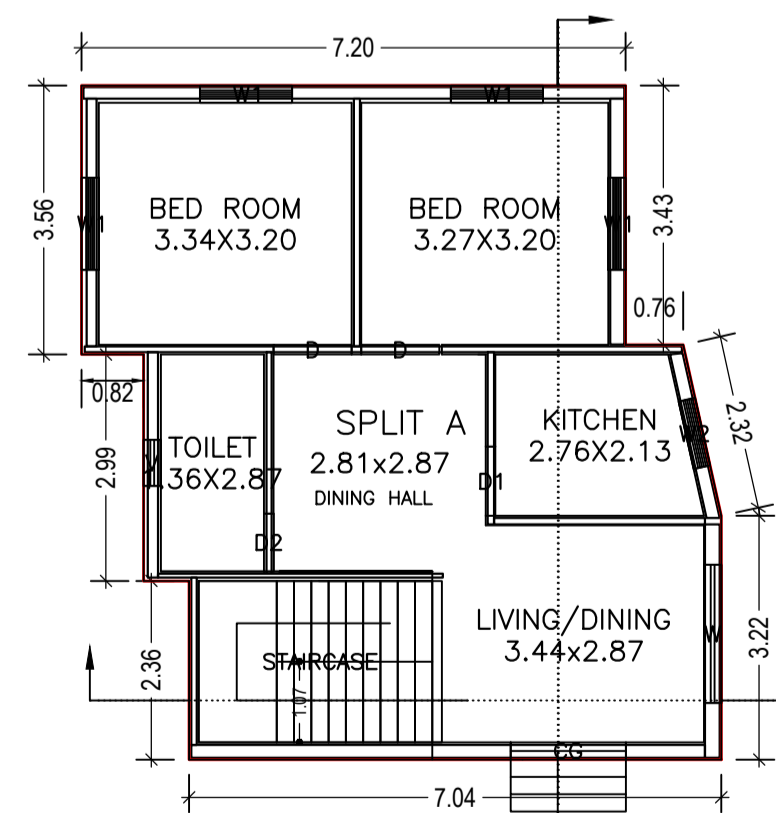

GROUND FLOOR PLAN (Proposed) (SCALE 1:100)

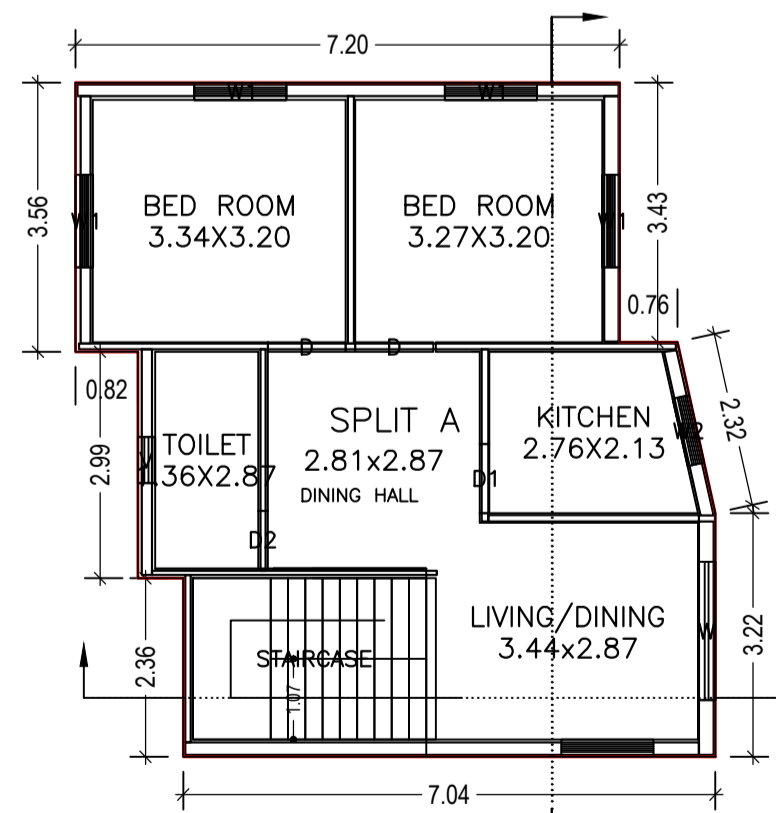

FIRST FLOOR PLAN (Proposed) (SCALE 1:100)

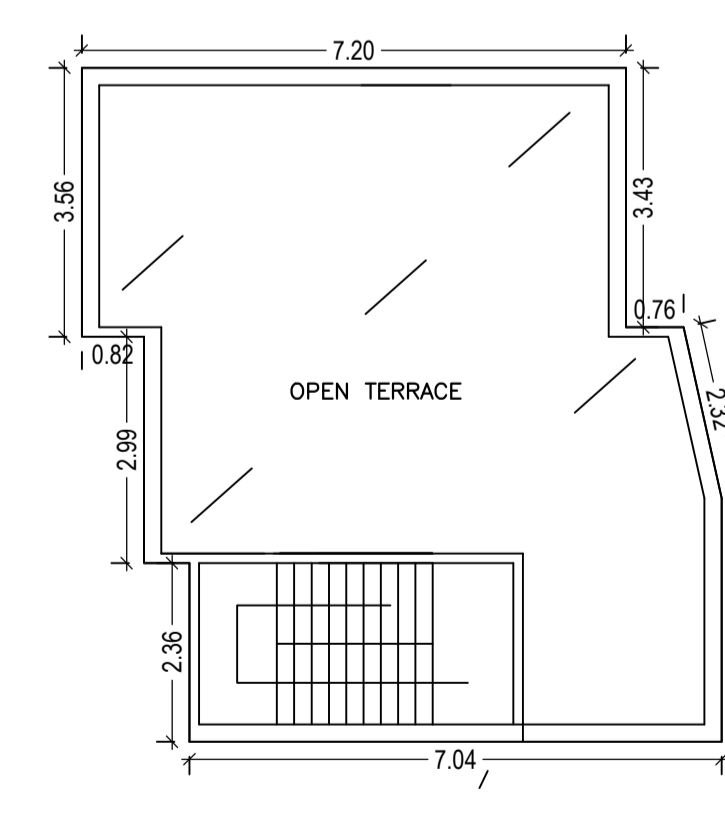

TERRACE FLOOR PLAN (SCALE 1:100)

SCHEDULE OF DOOR:

BUILDING NAME	NAME	LENGTH	HEIGHT	NOS
A (A)	D2	0.76	2.10	02
A (A)	D1	0.91	2.10	02
A (A)	D	1.03	2.10	04
A (A)	CG	1.52	2.10	01

SCHEDULE OF WINDOW/VENTILATION:

BUILDING NAME	NAME	LENGTH	HEIGHT	NOS
A (A)	V	0.61	0.60	02
A (A)	W2	0.91	1.20	02
A (A)	W1	1.22	1.20	08
A (A)	W	1.83	1.20	02

Building :A (A)

Floor Name	Total Built Up Area (Sq.mt.)	Proposed FAR Area (Sq.mt.)	Total FAR Area (Sq.mt.)	Total Consumed Additional FAR Area (Sq.mt.)	Tnmt (No.)
Ground Floor	64.70	64.70	64.70	64.70	01
First Floor	64.70	64.70	64.70	64.70	00
Terrace Floor	0.00	0.00	0.00	0.00	00
Total :	129.40	129.40	129.40	129.40	01
Total Number of Same Buildings	1				
Total :	129.40	129.40	129.40	129.40	01

Proposal Basic Information

Proposal File No.	DMC/BP/0139/W21/2018
Owner Name	RAJEEV KUMAR SINHA
Khata No	97
Plot No	4269
Village Name	Dhaiya
Use	Residential
SubUse	Semidetached

AREA STATEMENT

AREA OF PLOT (Minimum)	(A)	SQ.MT.	116.18
NET AREA OF PLOT(Gross Plot Area - Deduction from Gross Plot area)	(A-Deductions)		116.18
Deduction for Balance Plot Area(from Gross Plot Area)			
Common Plot			28.64
Total			28.64
BALANCE AREA OF PLOT(Net Plot Area - Recreational/Amenity space)	(A-Deductions)		87.53
PLOT AREA FOR COVERAGE(Net Plot Area)	(A-Deductions)		116.18
Plot Area for FAR (Net Plot Area + Road Widening Area)	(A-Deductions)		116.18

COVERAGE CHECK

Permissible Coverage area ( 70.00 % )	81.33
Proposed Coverage Area ( 55.69 % )	64.70
Total Prop. Coverage Area ( 55.69 % )	64.70
Balance coverage area ( 14.31 % )	16.63

FAR CHECK

Perm. FAR Area ( 1.50 )	174.27
Total Perm. FAR area	174.27
Residential FAR	129.39
Proposed FAR Area	129.39
Total Proposed FAR Area	129.39
Consumed FAR (Factor)	1.11
Balance FAR Area	44.88

BUILT UP AREA CHECK

Total Proposed BuiltUp Area	129.40
-----------------------------	--------

ARCHITECT (Regd) ASHOK KUMAR  
ENGINEER (Regd)  
SUPERVISOR (Regd)  
OWNER (Regd) RAJEEV KUMAR SINHA

COLOR INDEX

PLOT BOUNDARY	Black
ABUTTING ROAD	Green
PROPOSED CONSTRUCTION	Red
COMMON PLOT	Yellow
ROAD WIDENING AREA	Blue
EXISTING (To be retained)	Light Blue
EXISTING (To be demolished)	Dark Blue

Buildingwise Floor FAR Details

Floor Name	Building Name		Total	
	Proposed Built Up Area (Sq.mt.)	Proposed FAR Area (Sq.mt.)	Total Proposed Built Up Area (Sq.mt.)	Total FAR Area (Sq.mt.)
Ground Floor	64.70	64.70	64.70	64.70
First Floor	64.70	64.70	64.70	64.70
Terrace Floor	0.00	0.00	0.00	0.00
Total :	129.40	129.40	129.40	129.40

UnitBUA Table for Building :A (A)

FLOOR	Name	UnitBUA Type	UnitBUA Area	Carpet Area	No. of Rooms	No. of Tenement
GROUND FLOOR PLAN	SPLIT A	FLAT	129.39	116.42	5	1
FIRST FLOOR PLAN	SPLIT A	FLAT	0.00	0.00	5	0
Total:	-	-	129.39	116.42	10	1

FAR & Tenement Details (Table 4c-1)

Building	No. of Same Bldg	Total Built Up Area (Sq.mt.)	Proposed FAR Area (Sq.mt.)	Total FAR Area (Sq.mt.)	Total Consumed Additional FAR Area (Sq.mt.)	Tnmt (No.)
A (A)	1	129.40	129.40	129.40	129.40	01
Grand Total :	1	129.40	129.40	129.40	129.40	01

Building USE/SUBUSE Details

Building Name	Building Use	Building SubUse	Building Structure
A (A)	Residential	Residential Bldg/Apartment	Non-Highrise

LTP NAME AND SIGNATURE ASHOK KUMAR DMC/ENG/0011/2017	STRUCTURAL ENG'S NAME AND SIGNATURE	BUILDER NAME AND SIGNATURE	DIGITAL SIGNATURE
--	-------------------------------------	----------------------------	-------------------

Proposal Basic Information

Proposal File No.	DMC/BP/0139/W21/2018
Owner Name	RAJEEV KUMAR SINHA
Khata No	97
Plot No	4269
Village Name	Dhaiya
Use	Residential
SubUse	Semidetached

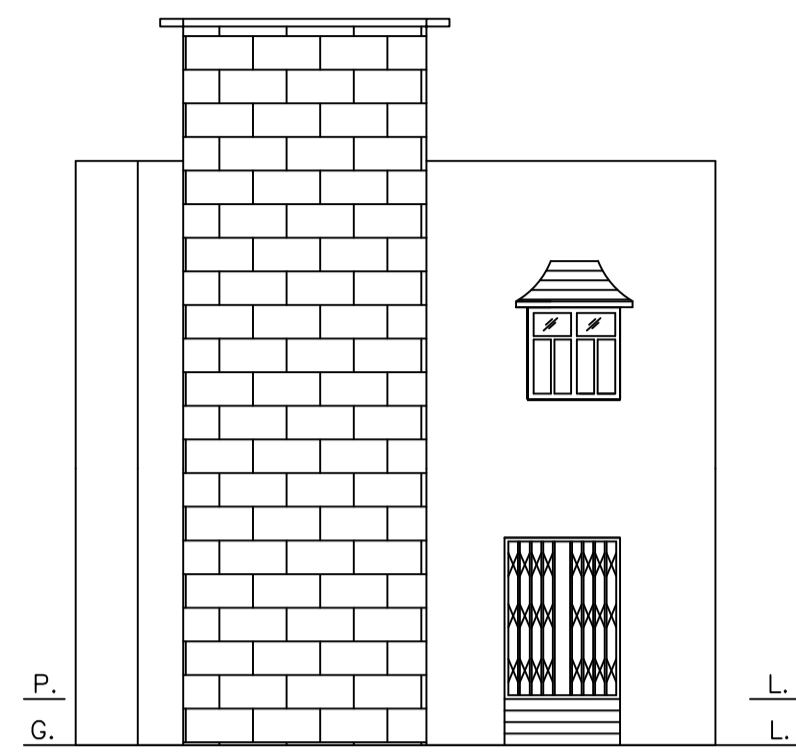

FRONT ELEVATION

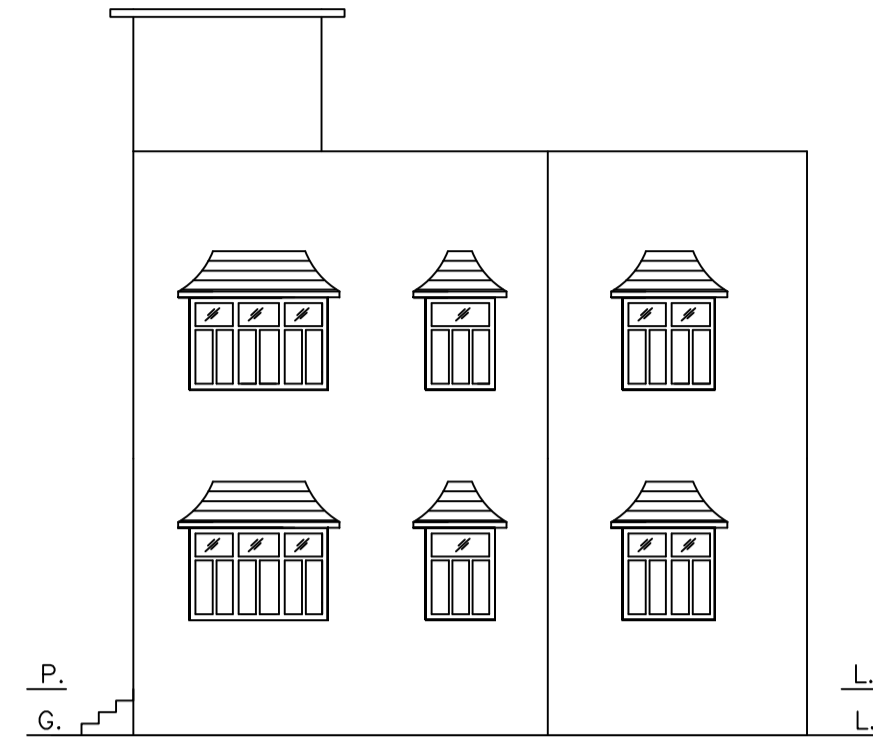

RIGHT SIDE ELEVATION

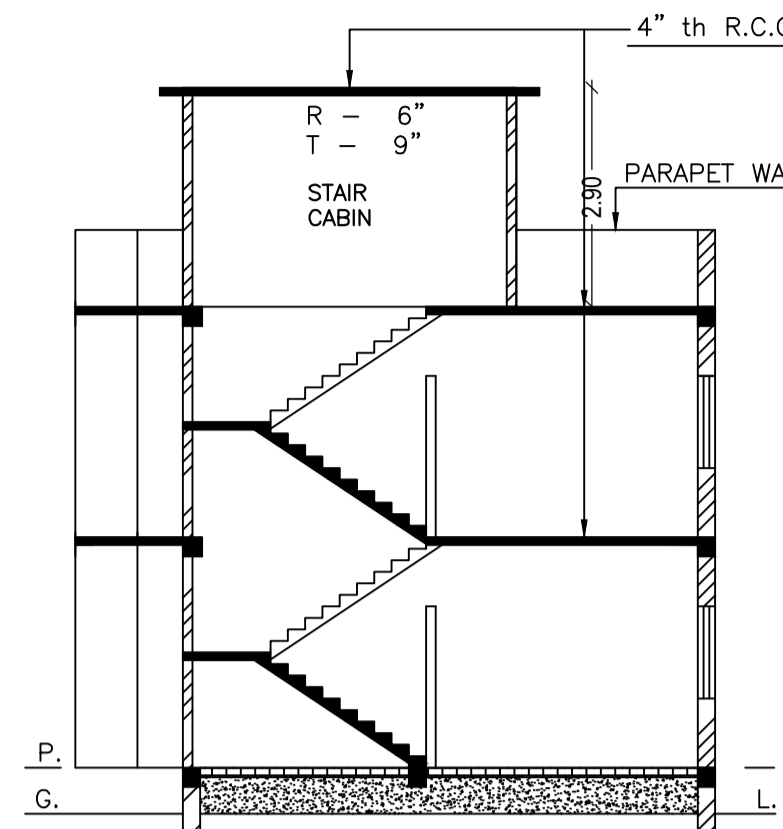

SECTION ON - XX

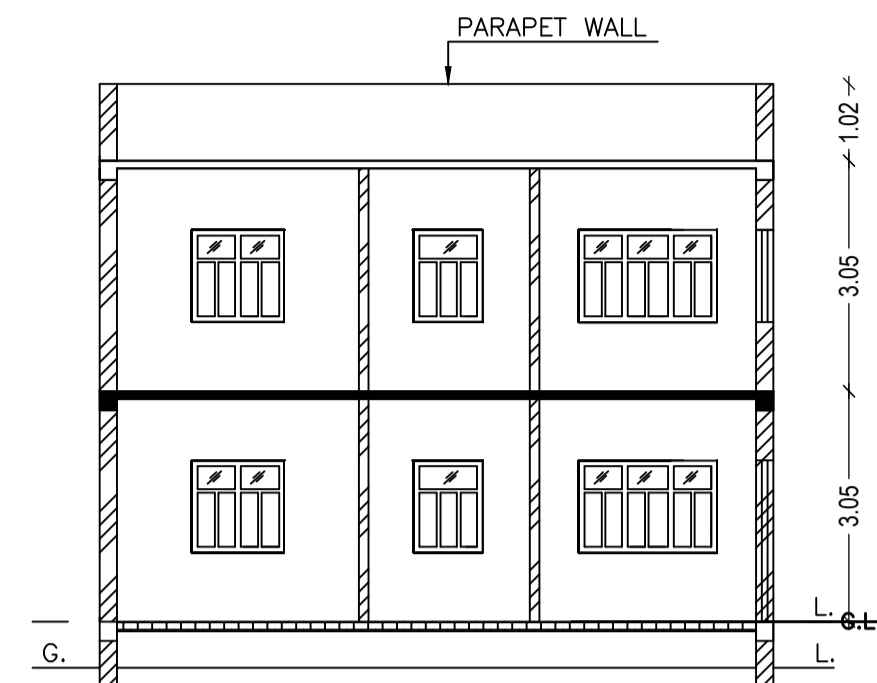

SECTION ON - YY

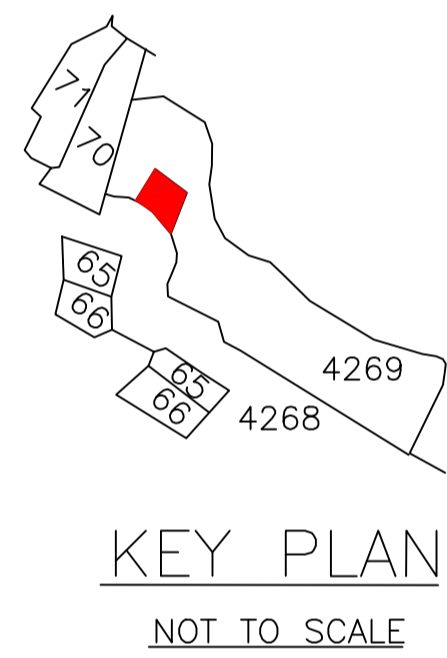

KEY PLAN  
NOT TO SCALE

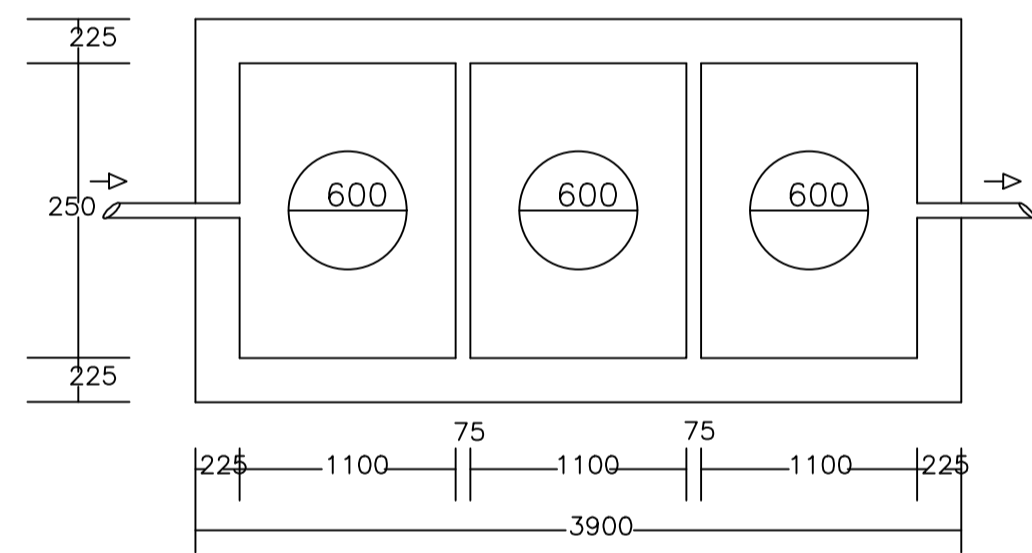
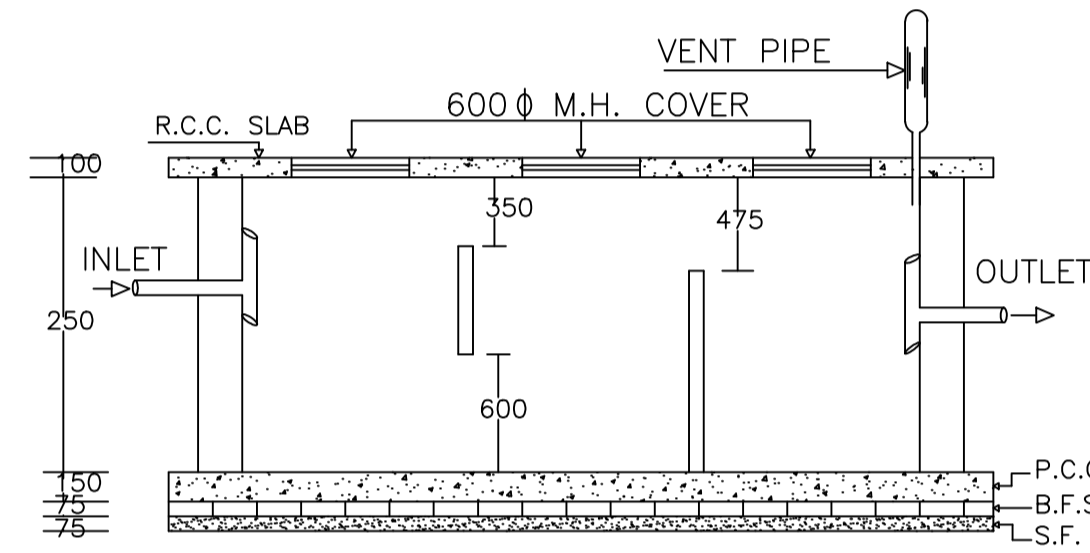

PLAN OF SEPTIC TANK

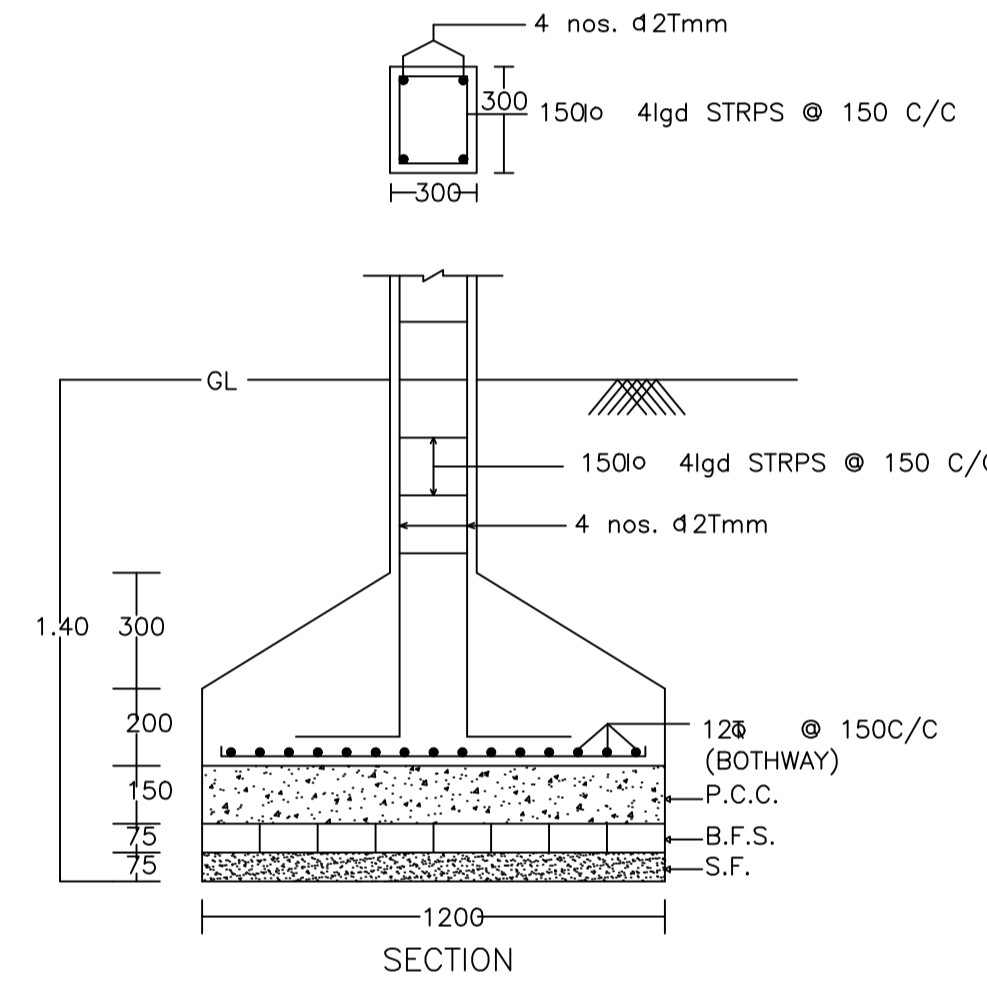

SECTION

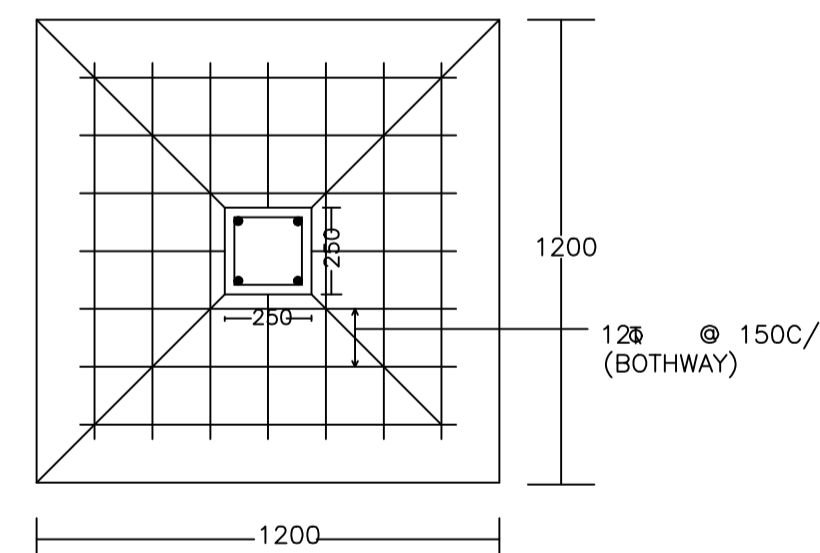

PLAN

DETAIL OF COLUMNS

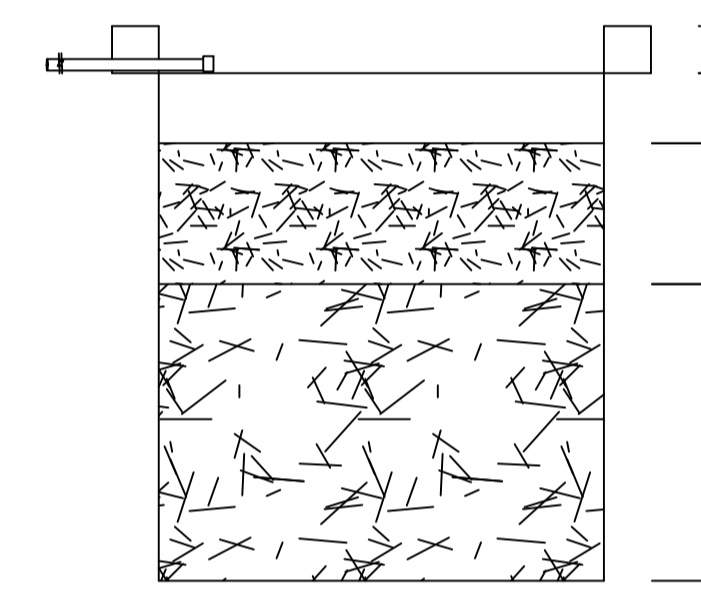

SECTION AT Y-Y

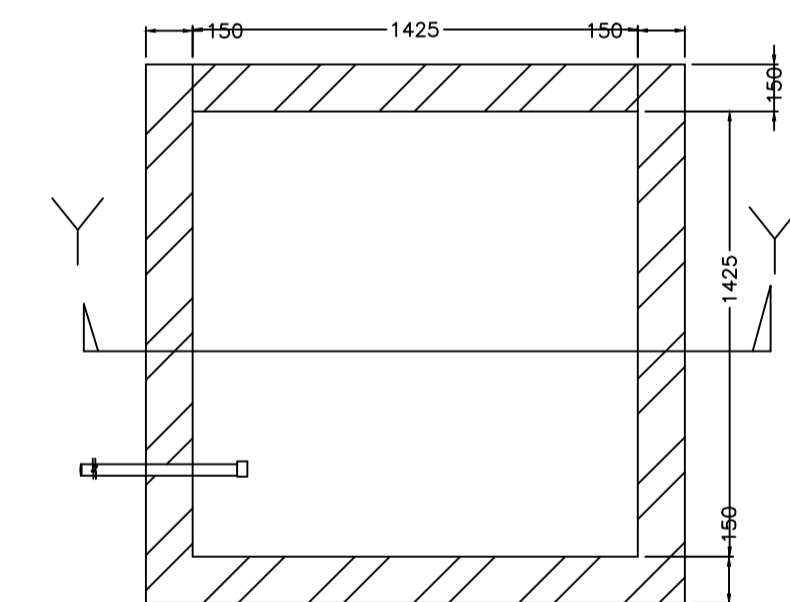

PLAN OF RECHARGE WELL

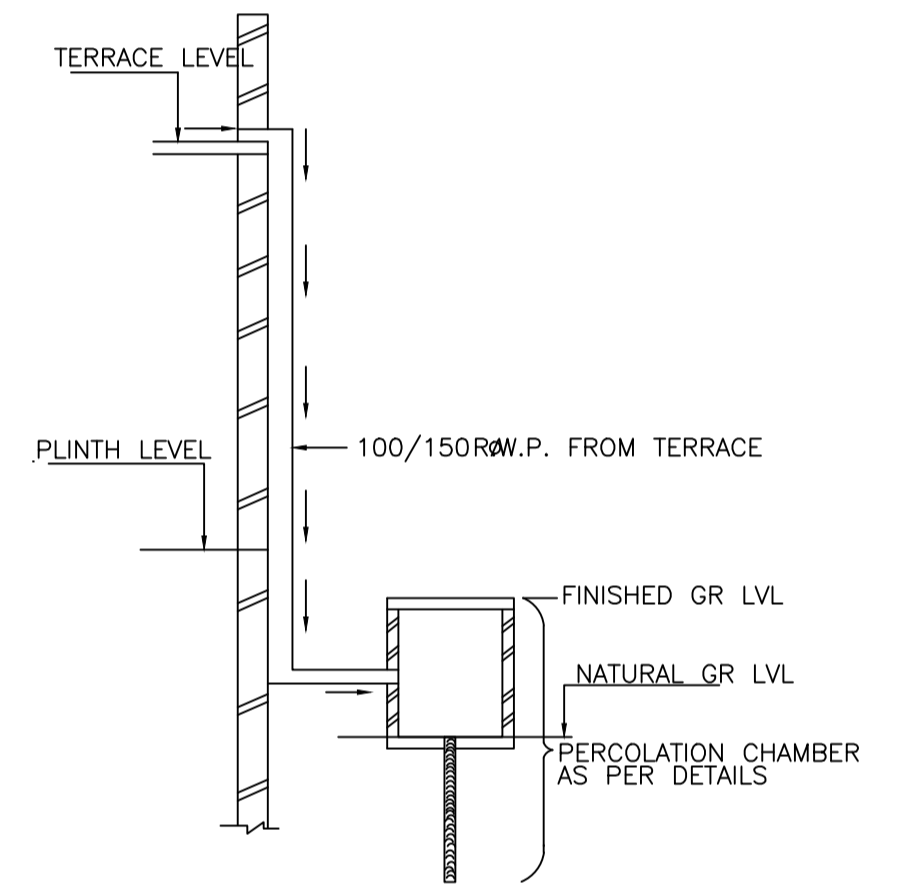

ROOF TOP RAIN WATER COLLECTION SYSTEM

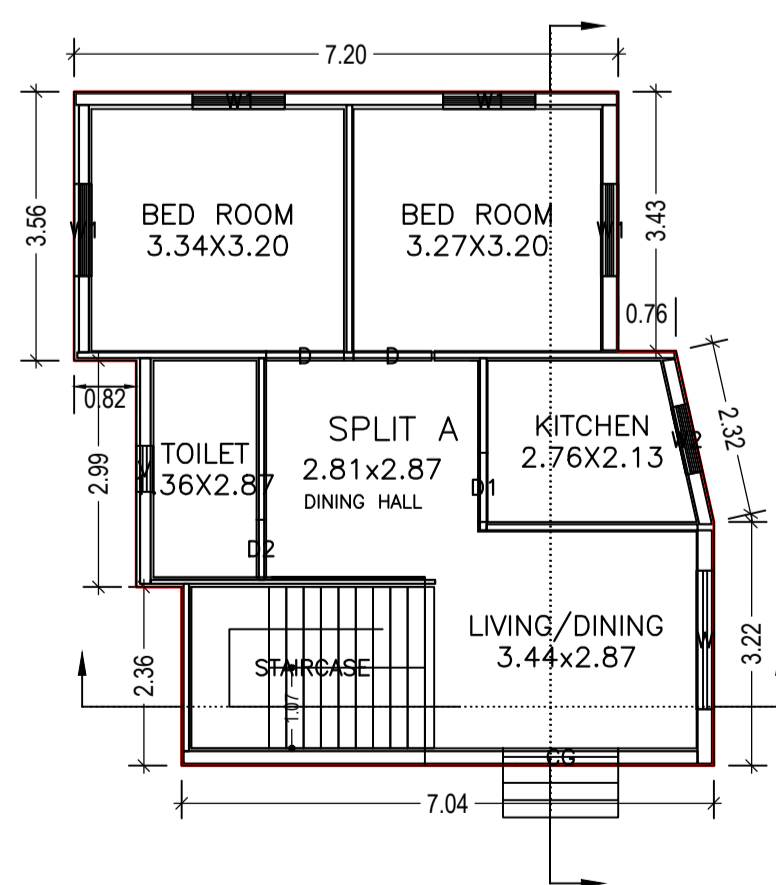

GROUND FLOOR PLAN  
(Proposed)  
(SCALE 1:100)

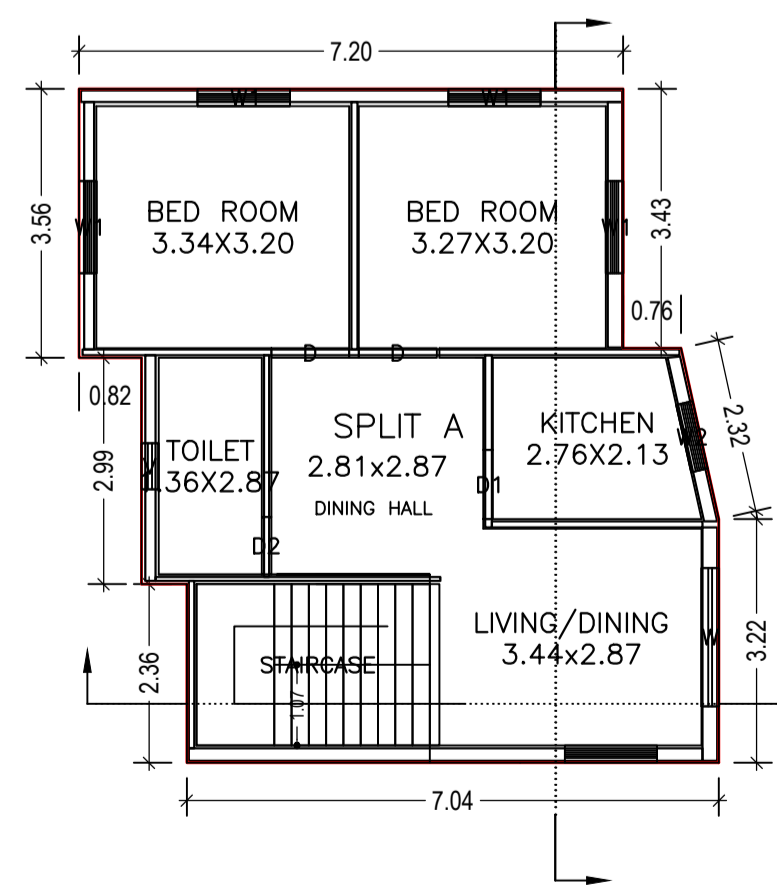

FIRST FLOOR PLAN  
(Proposed)  
(SCALE 1:100)

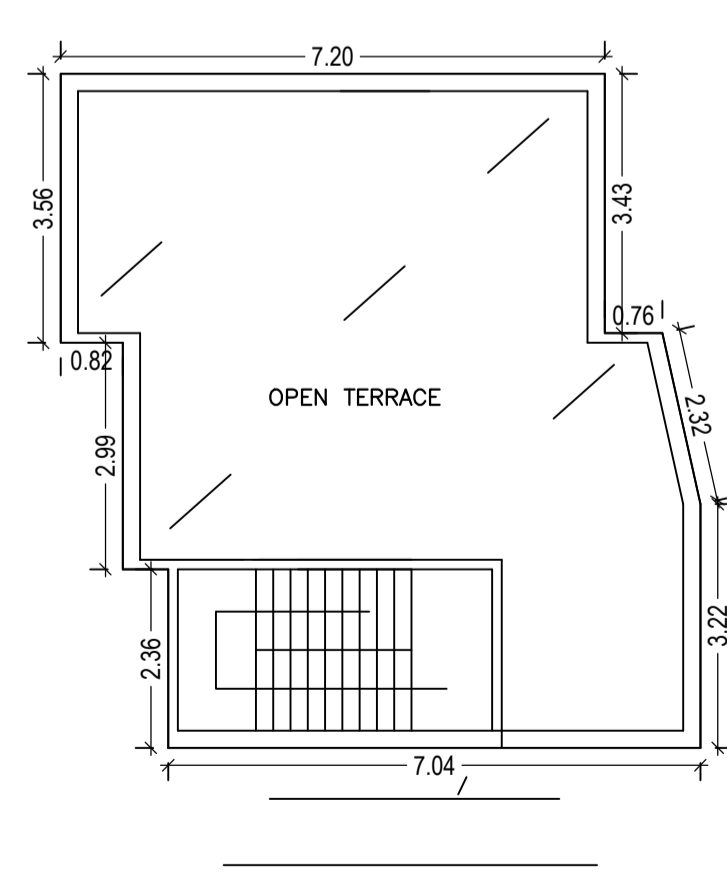

TERRACE FLOOR PLAN  
(SCALE 1:100)

WATER HARVESTING

LTP NAME AND SIGNATURE	STRUCTURAL ENG'S NAME AND SIGNATURE	BUILDER NAME AND SIGNATURE	DIGITAL SIGNATURE
ASHOK KUMAR DMC/ENG/0011/2017			