

Project Title :SRI HRIDAYANAND SINGH

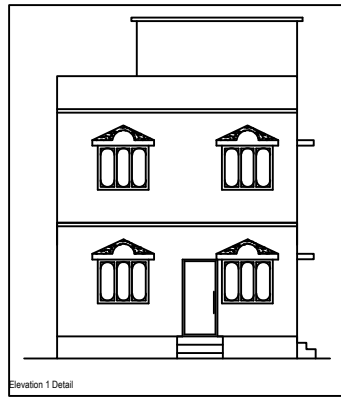

FRONT ELEVATION

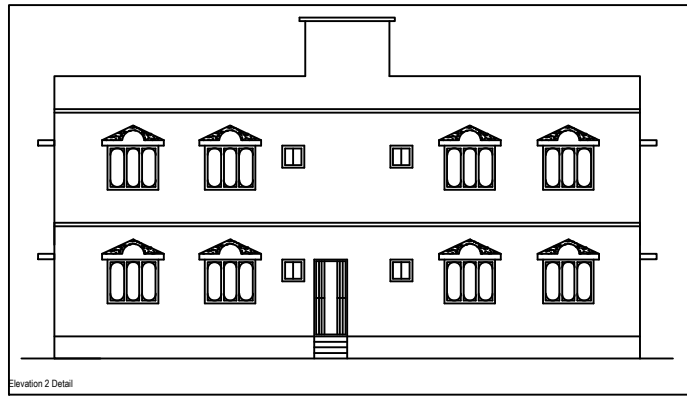

RIGHT SIDE ELEVATION

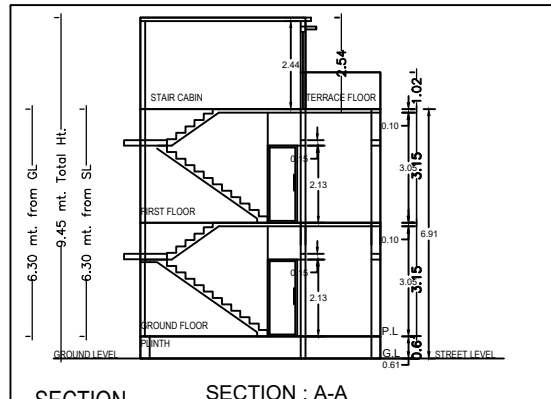

SECTION SECTION : A-A

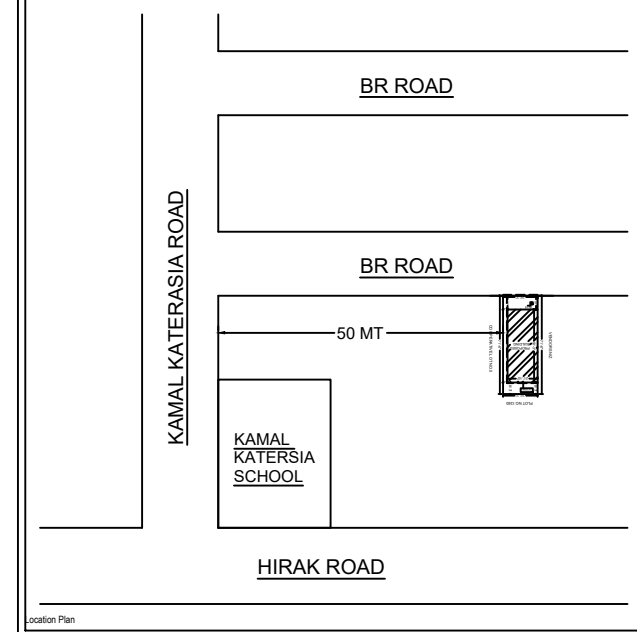

LOCATION PLAN

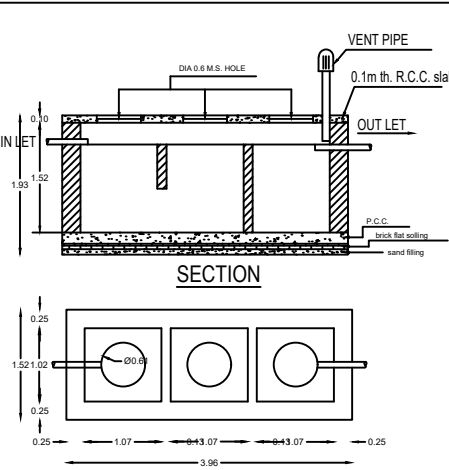

DETAILS OF SEPTIC TANK

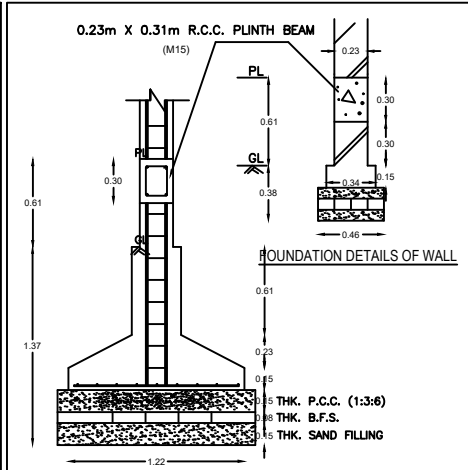

FOUNDATION DETAILS OF COLUMN

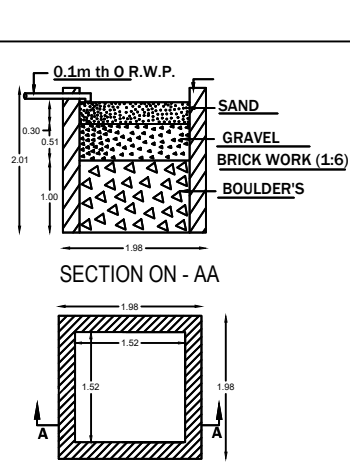

DETAIL'S OF WATER HARVESTING

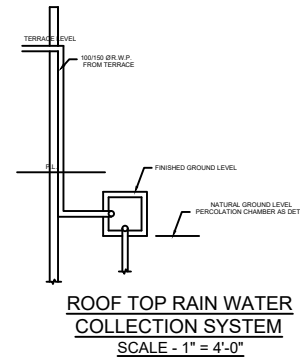

ROOF TOP RAIN WATER COLLECTION SYSTEM SCALE - 1" = 4'-0"

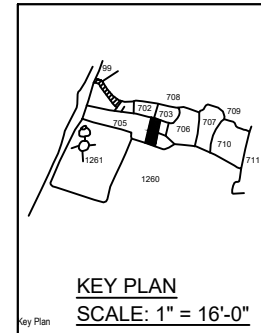

KEY PLAN SCALE: 1" = 16'-0"

BRIEF SPECIFICATION

- FOUNDATION : 6" th. P.C.C. (1:2:4) foundation bed & first class brick work in cement mortar (1:8) in foundation.
- PLINTH : 1 1/2" th. D.P.C. (1:2:4) all round on the plinth level.
- FLOORING : 1 1/2" th. I.P.S./ Marble flooring over 3" th. P.C.C. (1:3:6).
- SUPERSTRUCTURE : First work brick work in cement mortar (1:6).
- SLAB, BEAM & LINTEL : All R.C.C. works (1:1 1/2:3).
- WOOD WORKS : All doors & windows frames of sal wood.
- PLASTERING : 1/2" th. cement plaster (1:6) in both side.

SCHEDULE

| | | | | | |
|----|---|---------------|----|---|---------------|
| D | - | 3'-6" X 7'-0" | W | - | 4'-0" X 4'-0" |
| D1 | - | 3'-0" X 7'-0" | W1 | - | 3'-0" X 4'-0" |
| D2 | - | 2'-6" X 7'-0" | W2 | - | 5'-0" X 4'-0" |
| | | | V | - | 2'-0" X 2'-0" |

DETAILS OF AREA

| | | |
|-----------------------|---|-------------|
| LAND AREA AS PER DEED | : | 167.23 Smt. |
| LAND AREA AS PER SITE | : | 167.17 Smt. |
| GROUND FLOOR AREA | : | 105.12 Smt. |
| FIRST FLOOR AREA | : | 105.12 Smt. |
| COVERED AREA | : | 210.24 Smt. |
| % OF PLINTH AREA | : | 62.88 % |
| F.A.R | : | 1.26 |

TITLE OF DRAWING

PLAN FOR PROPOSED RESIDENTIAL BUILDING DRAWING OF SRI HRIDAYANAND SINGH, S/O. LATE RAMDEO SINGH UNDER MOUZA : BHELATAND, MOUZA NO. 89, KHATA NO. 87, PLOT NO.704 , 705 P.S. AND DISTT. OF D H A N B A D ,

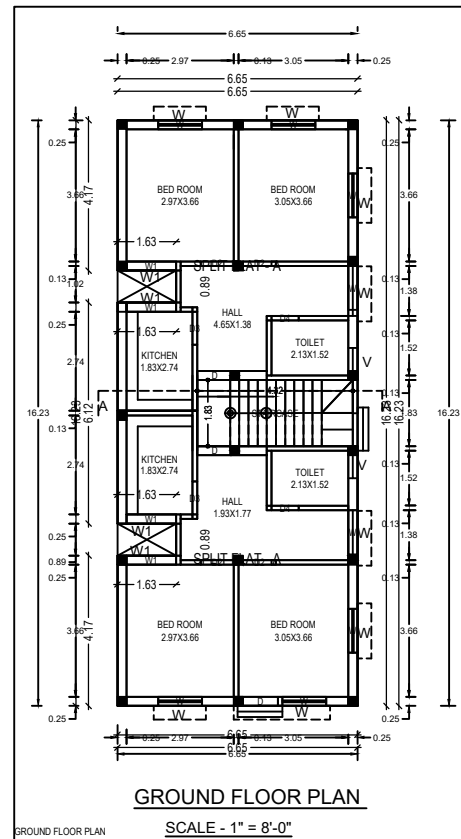

GROUND FLOOR PLAN

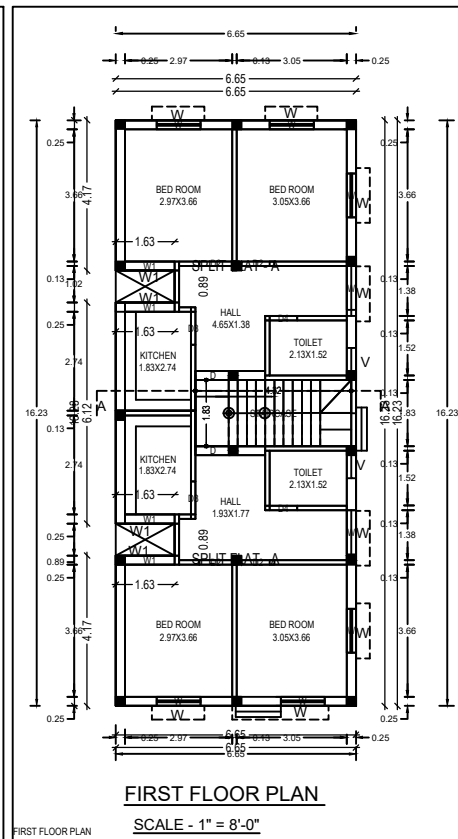

FIRST FLOOR PLAN

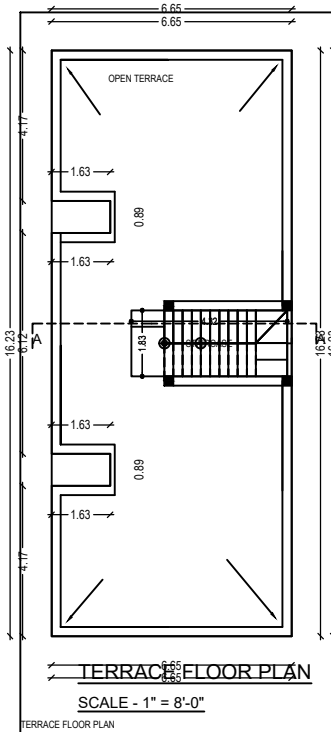

TERRACE FLOOR PLAN

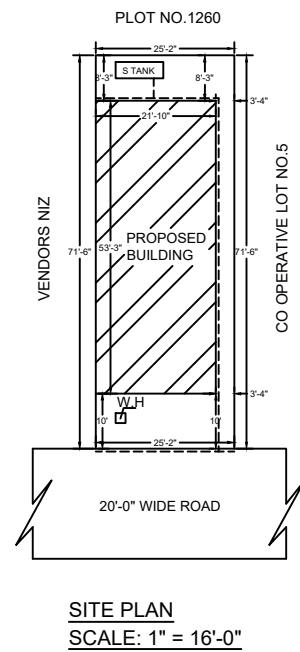

SITE PLAN SCALE: 1" = 16'-0"

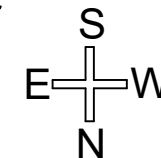

SIG. OF OWNER

SIG. OF ENGINEER