

SITE PLAN

Building USE/SUBUSE Details

Building Name	Building Use	Building SubUse	Building Structure
A (DR SANTOSH HOUSE)	Residential	Residential Bldg/Apartment	Non-Highrise

SCHEDULE OF DOOR:

BUILDING NAME	NAME	LENGTH	HEIGHT	NOS
A (DR SANTOSH HOUSE)	D2	0.75	2.10	09
A (DR SANTOSH HOUSE)	D1	0.90	2.10	03
A (DR SANTOSH HOUSE)	D	1.00	2.10	08
A (DR SANTOSH HOUSE)	D0	1.20	2.10	02

SCHEDULE OF WINDOW/VENTILATION:

BUILDING NAME	NAME	LENGTH	HEIGHT	NOS
A (DR SANTOSH HOUSE)	V	0.60	0.60	11
A (DR SANTOSH HOUSE)	W1	0.90	1.20	12
A (DR SANTOSH HOUSE)	W	1.20	1.20	22

Building :A (DR SANTOSH HOUSE)

Floor Name	Total Built Up Area (Sq.mt.)	Deductions (Area in Sq.mt.)	Proposed FAR Area (Sq.mt.)	Total FAR Area (Sq.mt.)	Total Consumed Additional FAR Area (Sq.mt.)	Tnmt (No.)
Ground Floor	188.46	10.80	177.66	177.66	177.66	01
First Floor	190.36	0.00	190.36	190.36	190.36	00
Terrace Floor	0.00	0.00	0.00	0.00	0.00	00
Total :	378.82	10.80	368.02	368.02	368.02	01

FAR & Tenement Details (Table 4c-1)

Building	No. of Same Bldg	Total Built Up Area (Sq.mt.)	Deductions (Area in Sq.mt.)	Proposed FAR Area (Sq.mt.)	Total FAR Area (Sq.mt.)	Total Consumed Additional FAR Area (Sq.mt.)	Tnmt (No.)
A (DR SANTOSH HOUSE)	1	378.82	10.80	368.02	368.02	368.02	01
Grand Total :	1	378.82	10.80	368.02	368.02	368.02	01

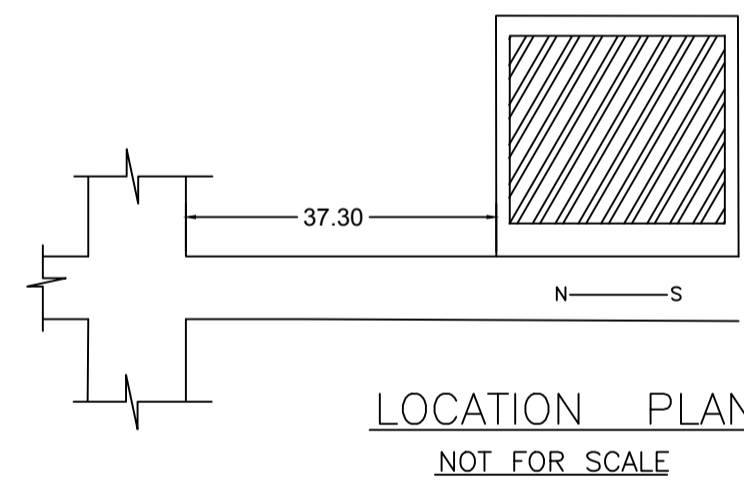

LOCATION PLAN
NOT FOR SCALE



KEY PLAN
Not to Scale

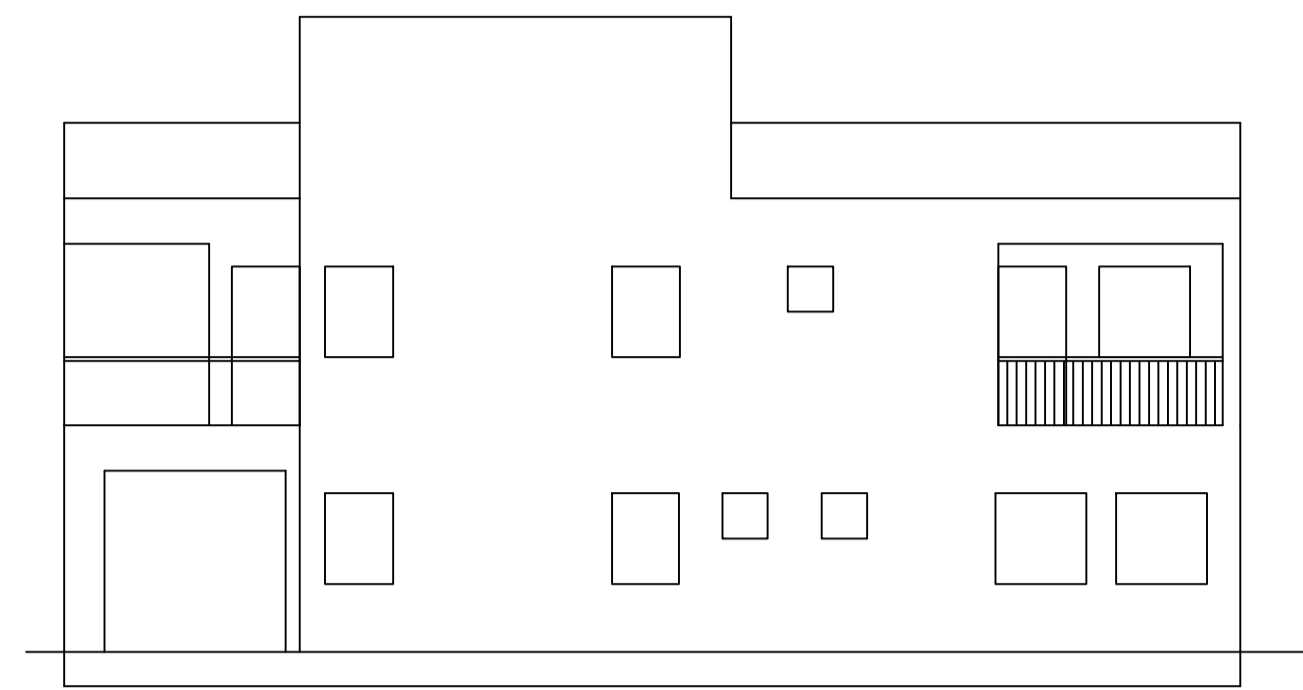

Front Elevation

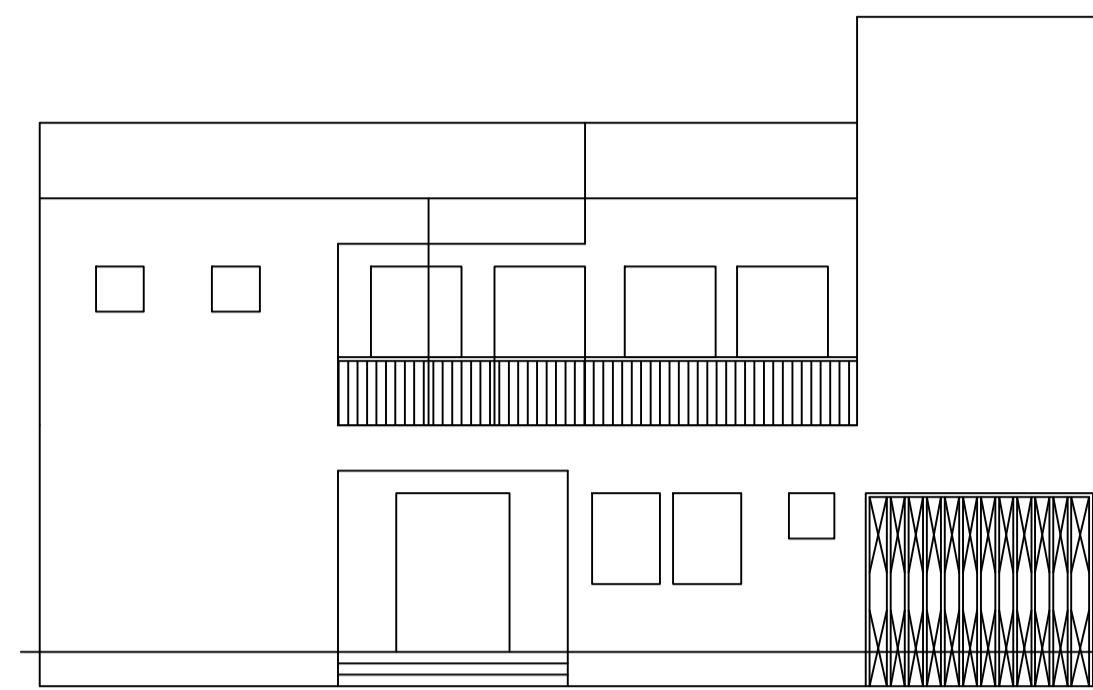

Left Side Elevation

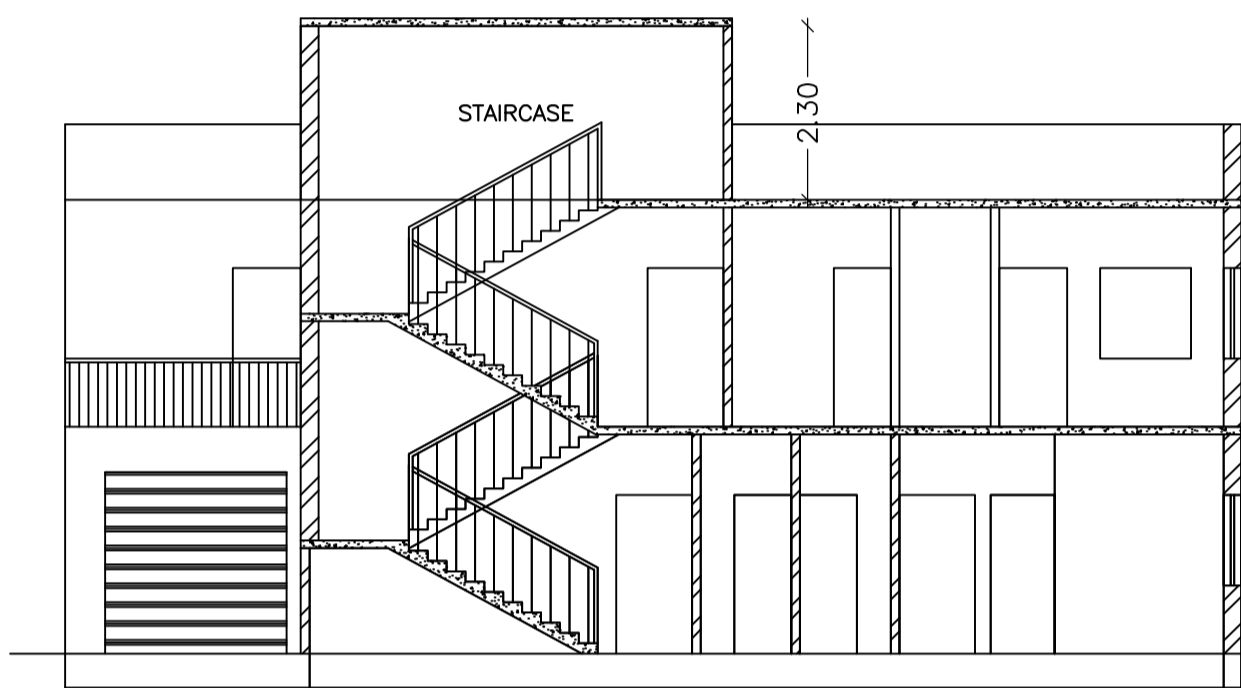

Section on X-X

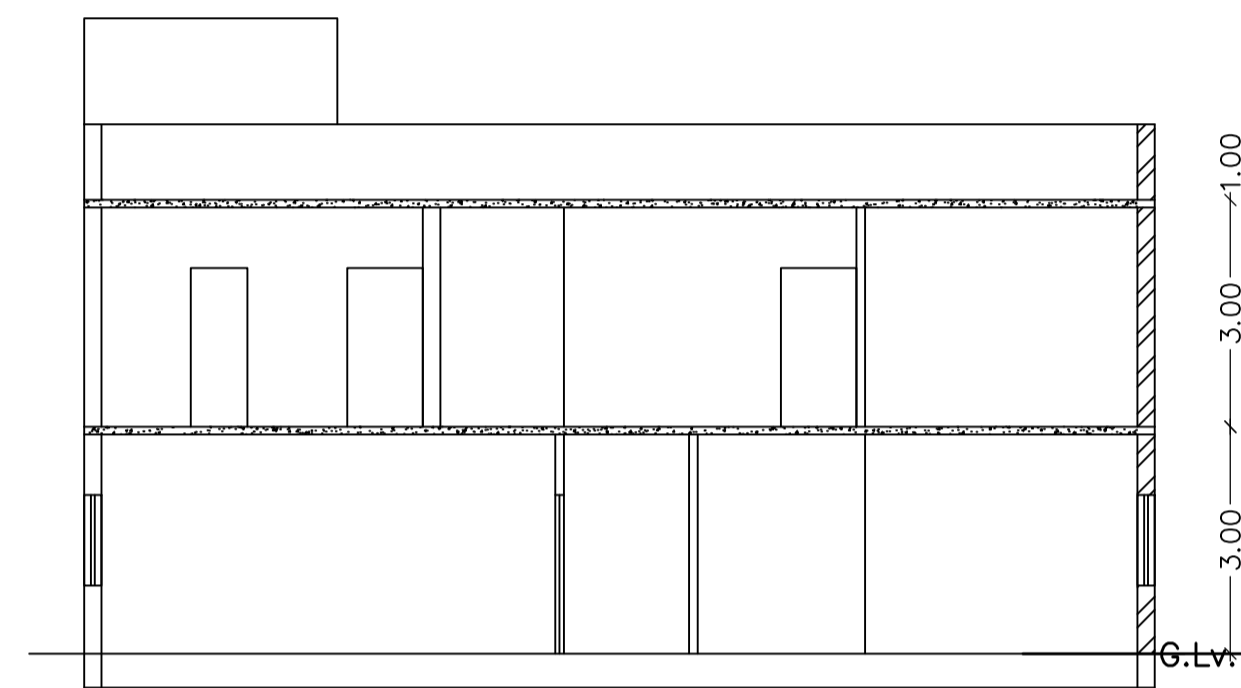

Section on Y-Y

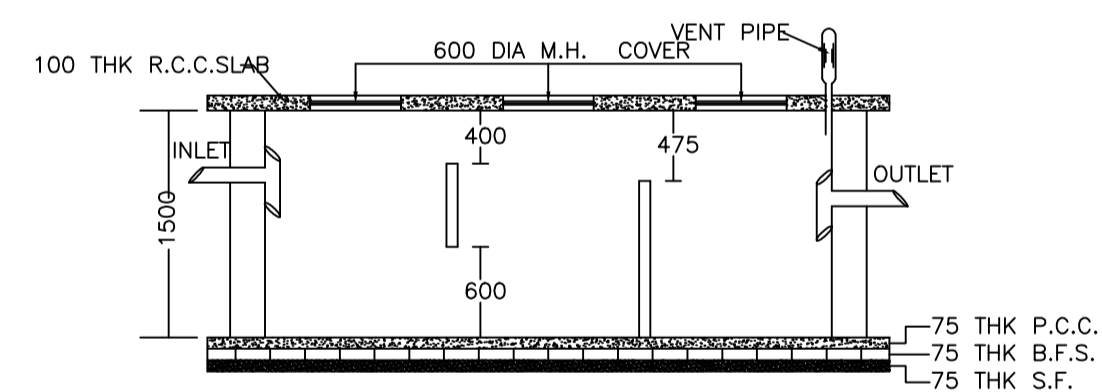

PLAN OF SEPTIC TANK

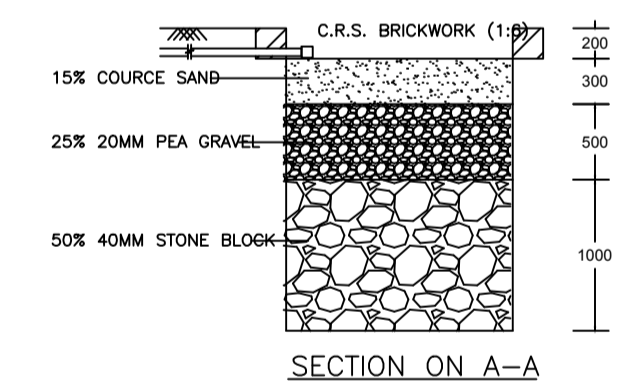

PLAN OF RECHARGE WELL (WATER HARVESTING)

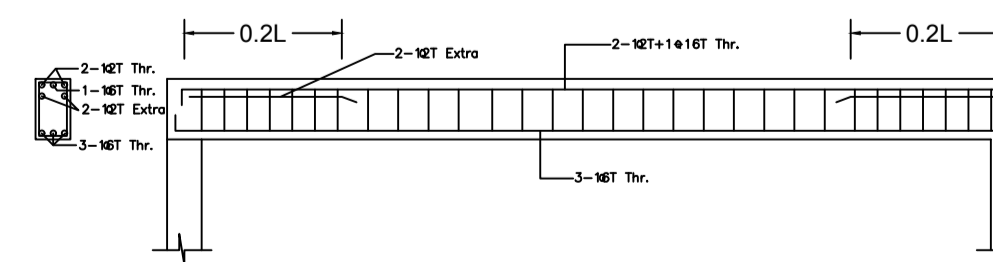
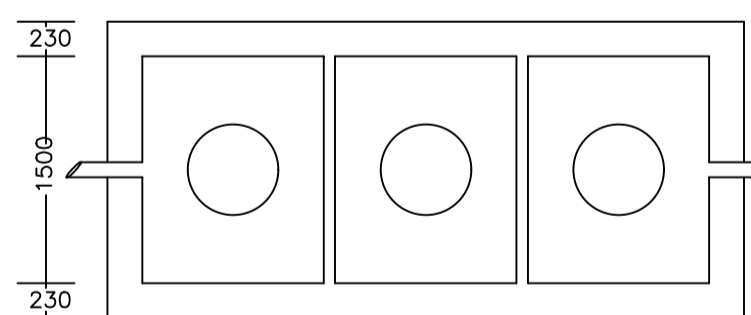

STRUCTURAL DETAILS OF BEAM

Proposal Basic Information

Proposal File No	DMC/BP/0145/W22/2018
Owner Name	Sri. Santosh Kumar
Khata No	63
Plot No	232
Village Name	Panarpala
Use	Residential
SubUse	Residential Bldg/Apartment

AREA STATEMENT		VERSION NO.:	1.0.31
DHANBAD MUNICIPAL CORPORATION		VERSION DATE:	30/06/2018
PROJECT DETAIL:			
Region:	JHARKHAND URBAN LOCAL BODIES	Plot Use:	Residential
District:	DHANBAD	Plot SubUse:	Residential Bldg/Apartment
Authority:	DHANBAD MUNICIPAL CORPORATION	PlotNearby/ReligiousStructure:	NA
Inward_No:	DMC/BP/0145/W22/2018	Plot/SubPlot No:	232
Application Type:	General Proposal	North:	Plot No. - PART OF THIS PLOT
Project Type:	Building Permission	South:	Plot No. - PART OF THIS PLOT
Nature of Development:	New	East:	Plot No. - PART OF THIS PLOT
Location of Development Area:	Old Area	West:	Road Width - 4.85
AREA DETAILS:			SQ.MT.
AREA OF PLOT (Minimum)	(A)		331.95
NET AREA OF PLOT (Gross Plot Area - Deduction from Gross Plot area)	(A-Deductions)		331.95
Deduction for Balance Plot Area (from Gross Plot Area)			
Common Plot			34.26
Total			34.26
BALANCE AREA OF PLOT (Net Plot Area - Recreational/Amenity space)	(A-Deductions)		297.69
PLOT AREA FOR COVERAGE (Net Plot Area)	(A-Deductions)		331.95
Plot Area for FAR (Net Plot Area + Road Widening Area)	(A-Deductions)		331.95
COVERAGE CHECK			
Permissible Coverage area (60.00 %)			199.17
Proposed Coverage Area (59.95 %)			198.99
Total Prop. Coverage Area (59.95 %)			198.99
Balance coverage area (0.05 %)			0.18
FAR CHECK			
Total Perm. FAR area			597.51
Residential FAR			597.51
Proposed FAR Area			368.02
Total Proposed FAR Area			368.02
Consumed FAR (Factor)			1.11
Balance FAR Area			229.49
BUILT UP AREA CHECK			
Total Proposed BuiltUp Area			378.82
ARCHITECT (Regd)			PIYUSH KANTI SINGH
ENGINEER (Regd)			
SUPERVISOR (Regd)			
OWNER (Regd)			

COLOR INDEX

PLOT BOUNDARY	Black
ABUTTING ROAD	Green
PROPOSED CONSTRUCTION	Red
COMMON PLOT	Yellow
ROAD WIDENING AREA	Blue
EXISTING (To be retained)	Light Blue
EXISTING (To be demolished)	Dark Blue

Buildingwise Floor FAR Details

Floor Name	Building Name		Total	
	Proposed Built Up Area (Sq.mt.)	Proposed FAR Area (Sq.mt.)	Total Proposed Built Up Area (Sq.mt.)	Total FAR Area (Sq.mt.)
Ground Floor	188.46	177.66	188.46	177.66
First Floor	190.36	190.36	190.36	190.36
Terrace Floor	0.00	0.00	0.00	0.00
Total :	378.82	368.02	378.82	368.02

UnitBUA Table for Building :A (DR SANTOSH HOUSE)

FLOOR	Name	UnitBUA Type	UnitBUA Area	Carpet Area	No. of Rooms	No. of Tenement
GROUND FLOOR PLAN	SPLIT 1	FLAT	368.02	361.42	15	1
FIRST FLOOR PLAN	SPLIT 1	FLAT	0.00	0.00	12	0
Total:	-	-	368.02	361.42	27	1

LTP NAME AND SIGNATURE PIYUSH KANTI SINGH DMC/ENG/0020/2016	STRUCTURAL ENG'S NAME AND SIGNATURE	SUBVENER NAME AND SIGNATURE	AUTOREAL SIGNATURE
---	-------------------------------------	-----------------------------	--------------------

Proposal Basic Information	
Proposal File No	DMC/BP/0145/W22/2018
Owner Name	Sri. Santosh Kumar
Khata No	63
Plot No	232
Village Name	Panarpala
Use	Residential
SubUse	Residential Bldg/Apartment

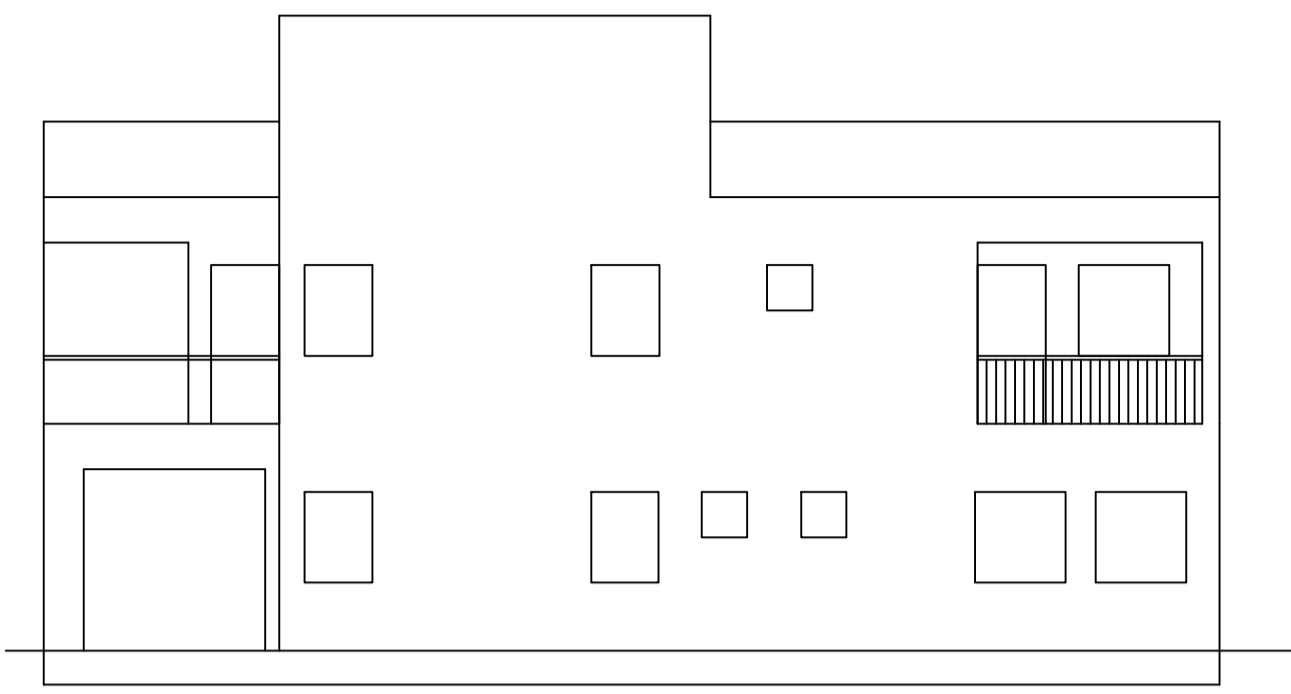

Front Elevation

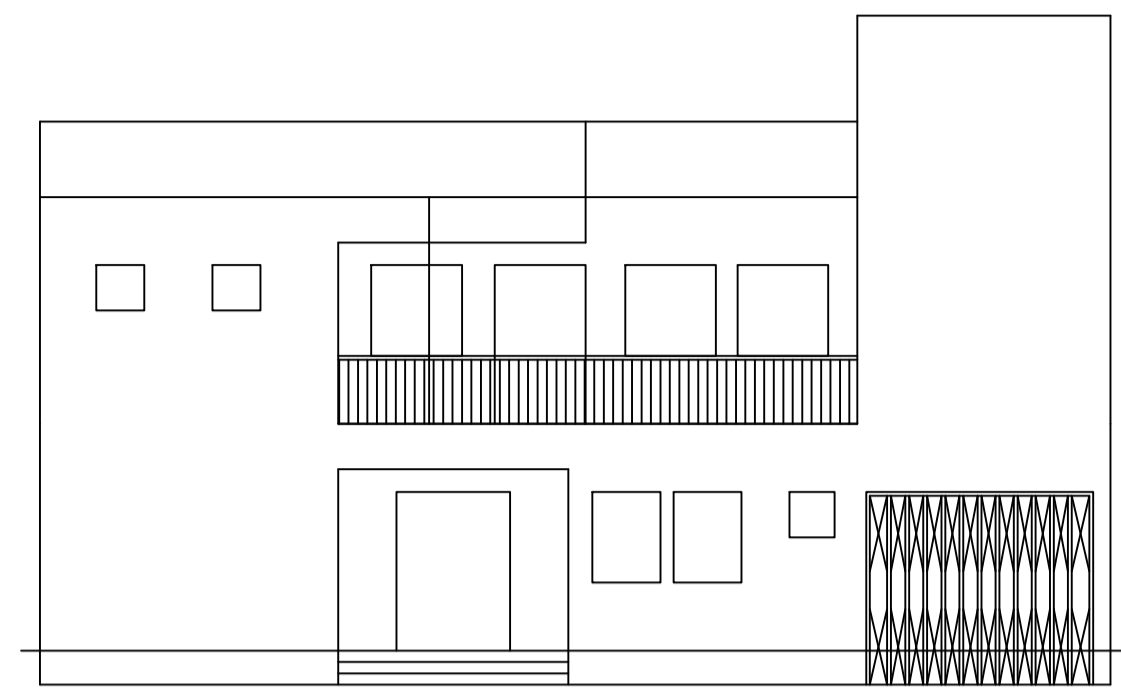

Left Side Elevation

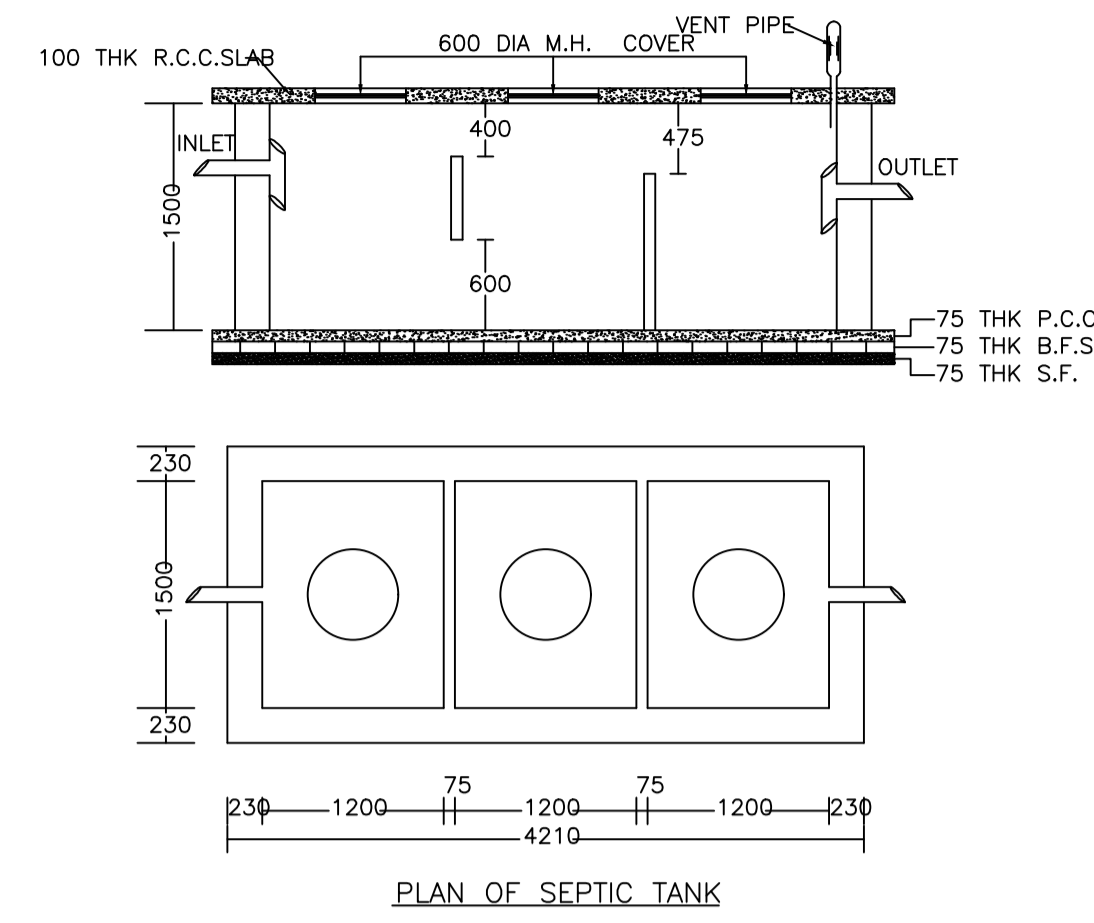

PLAN OF SEPTIC TANK

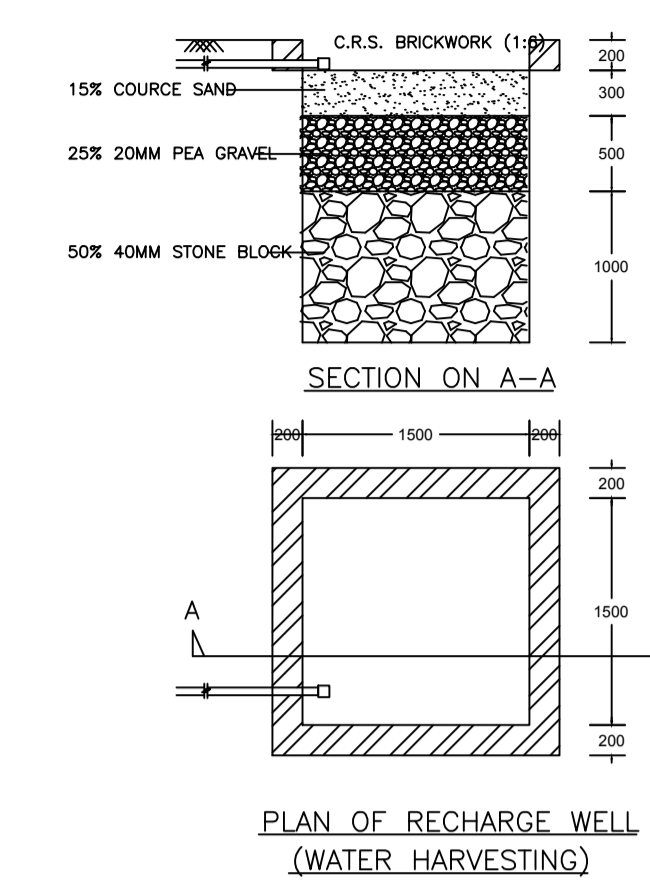

PLAN OF RECHARGE WELL (WATER HARVESTING)

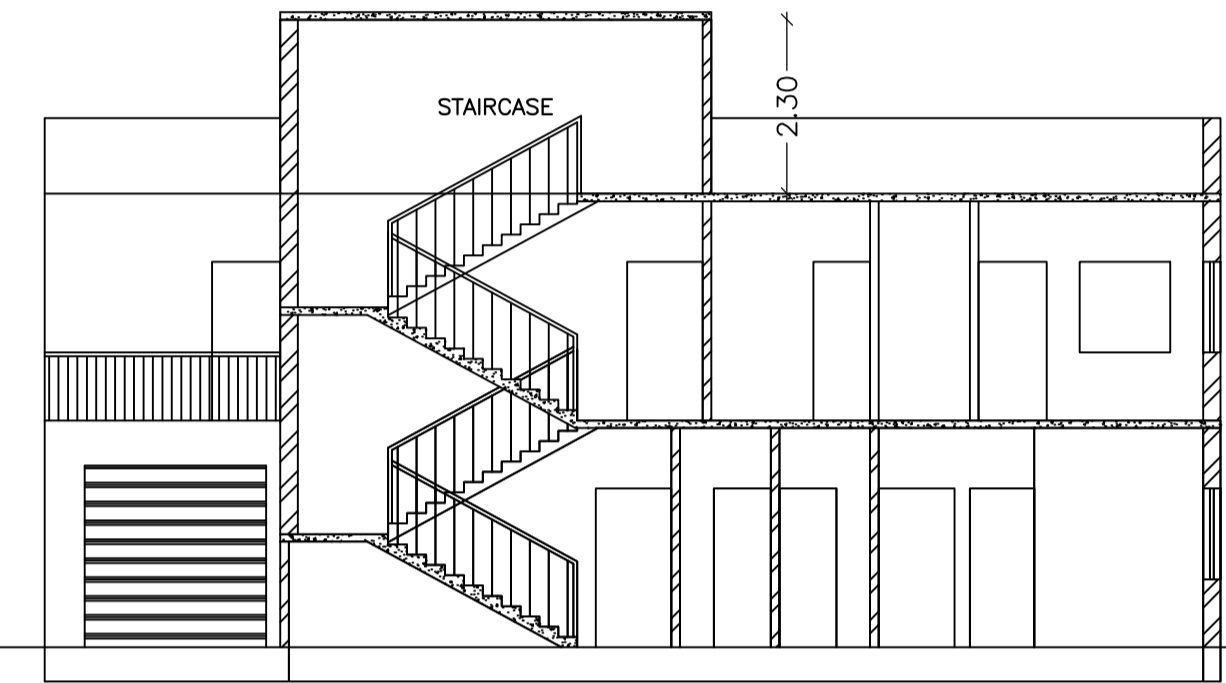

Section on X-X

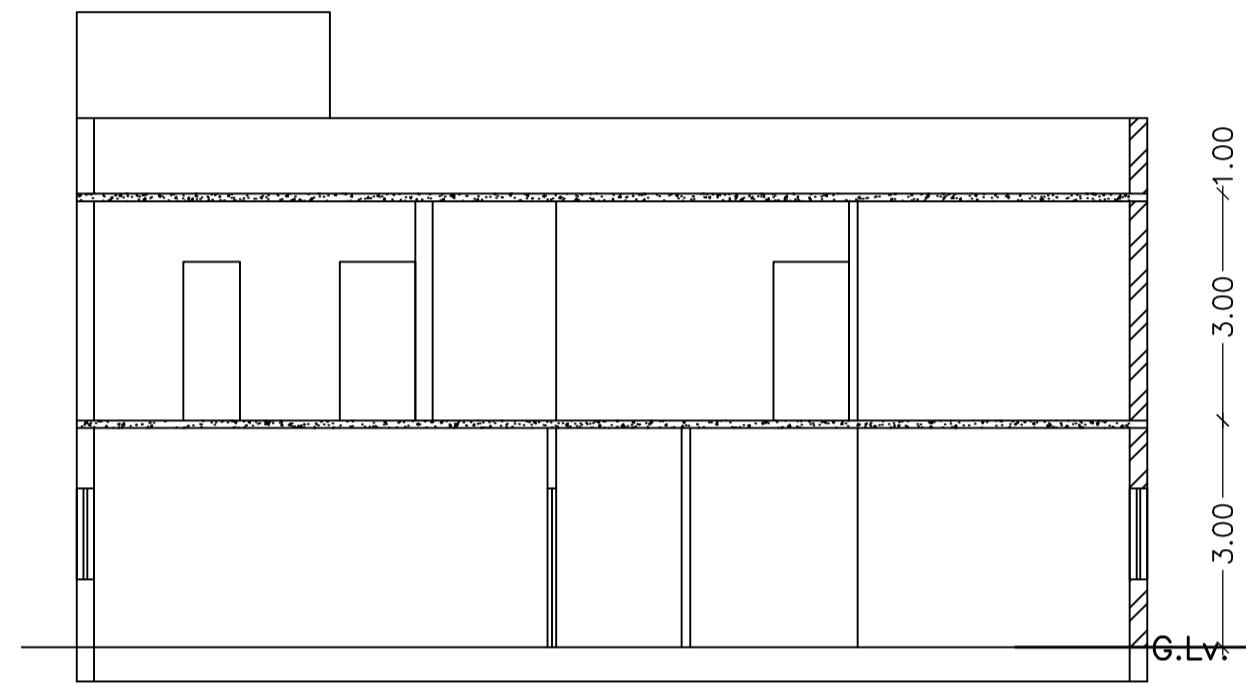

Section on Y-Y



KEY PLAN
Not to Scale

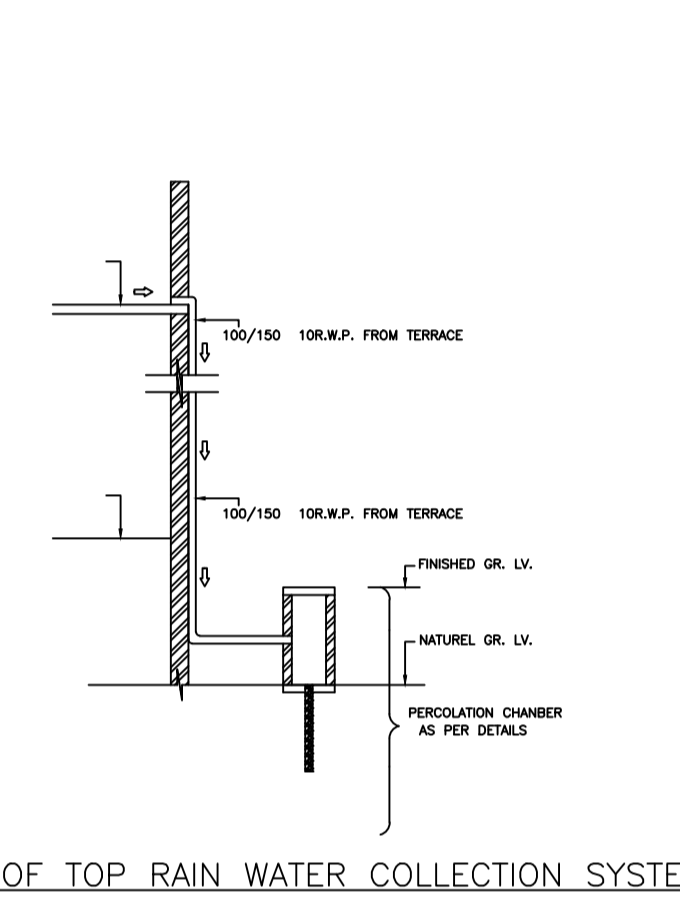

ROOF TOP RAIN WATER COLLECTION SYSTEM

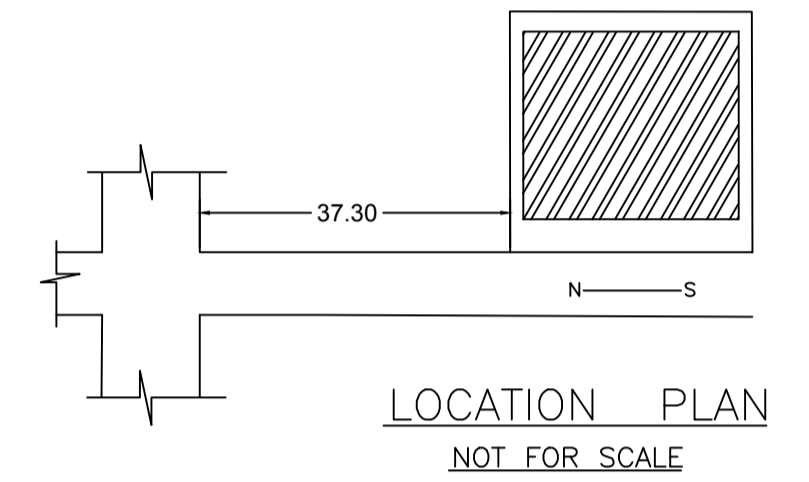

LOCATION PLAN
NOT FOR SCALE

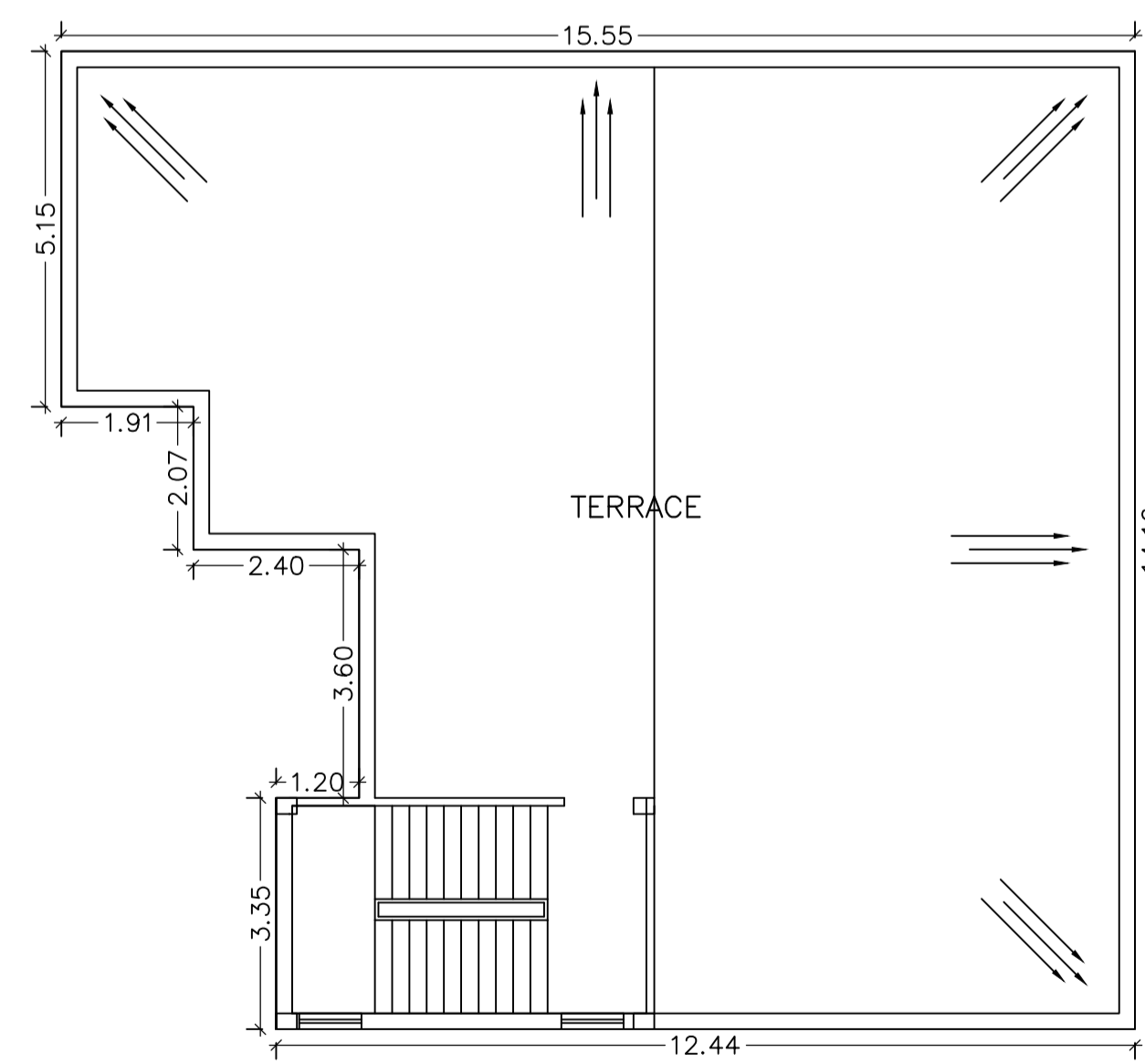

TERRACE FLOOR PLAN
(SCALE 1:100)

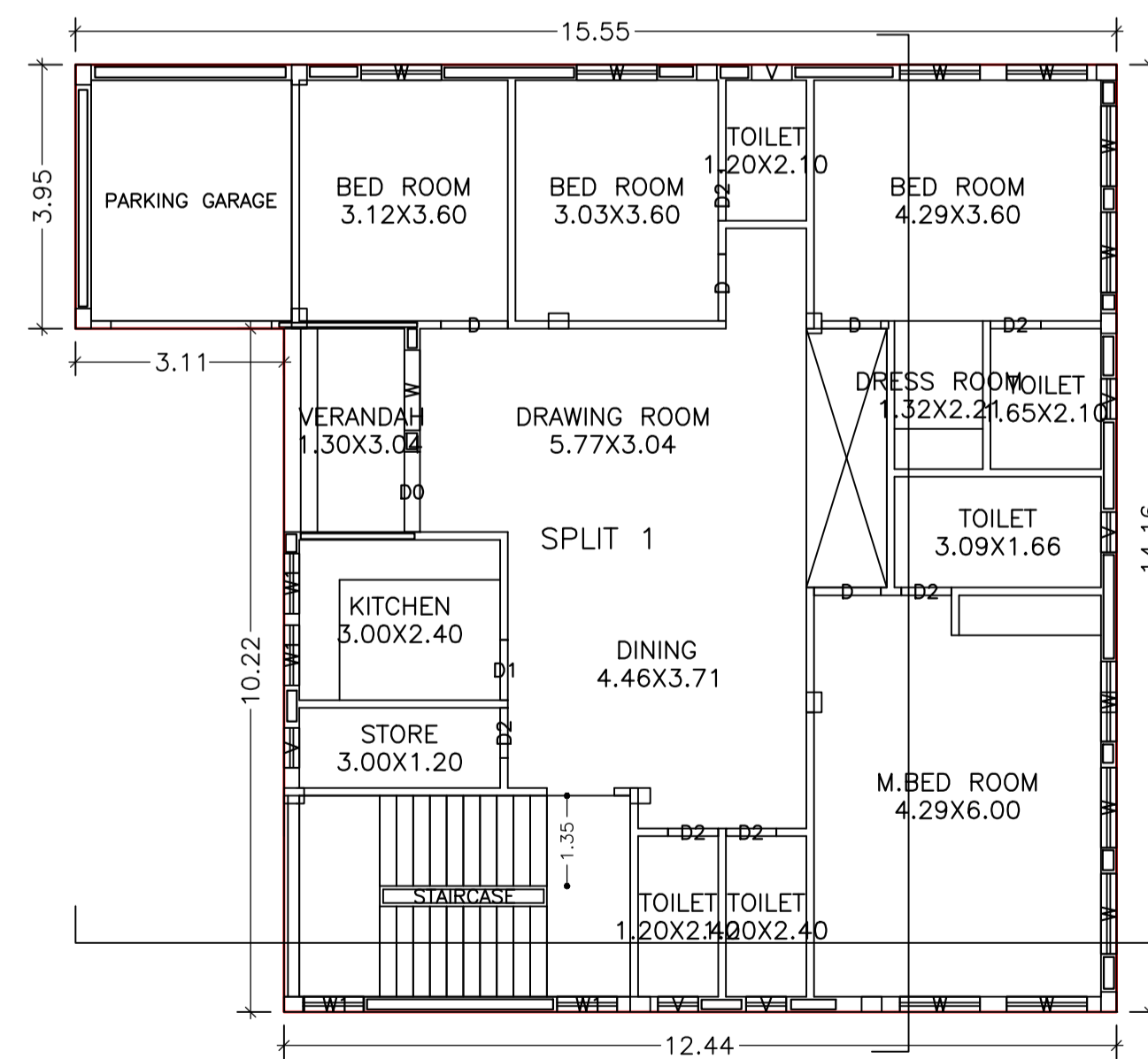

GROUND FLOOR PLAN
(Proposed)
(SCALE 1:100)

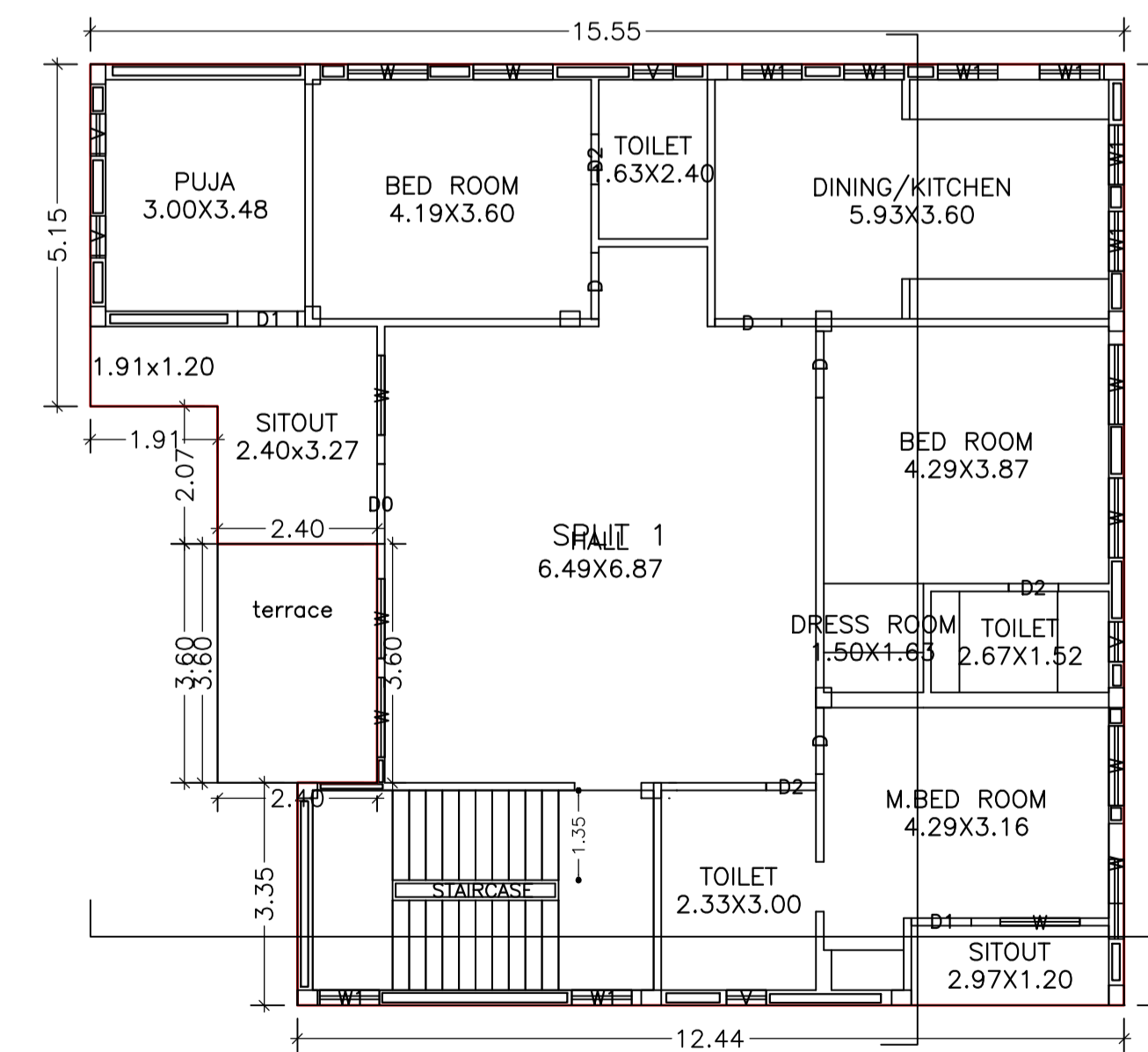

FIRST FLOOR PLAN
(Proposed)
(SCALE 1:100)

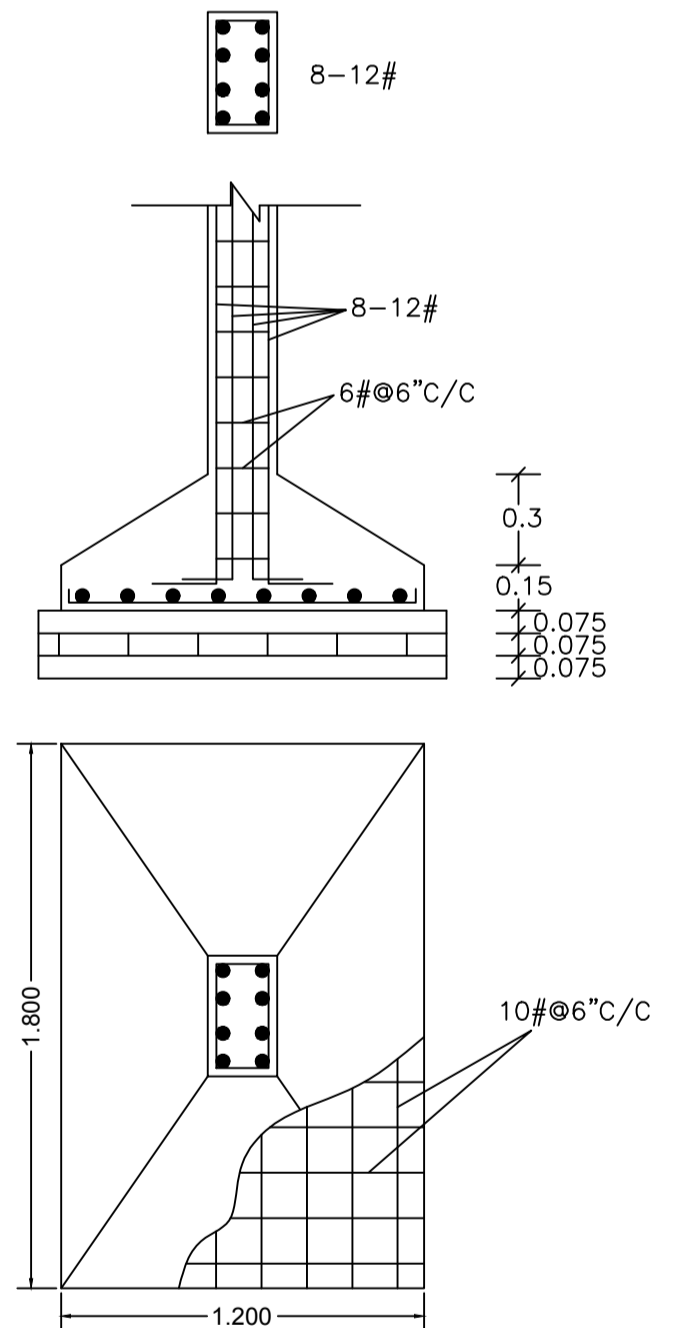

COLUMN DETAILS
SCALE:- 1:50

LTP NAME AND SIGNATURE	STRUCTURAL ENG'S NAME AND SIGNATURE	DESIGNER NAME AND SIGNATURE	AUTOREAL SIGNATURE
PIYUSH KANTI SINGH DMC/ENG/0020/2016			