

FRONT ELEVATION

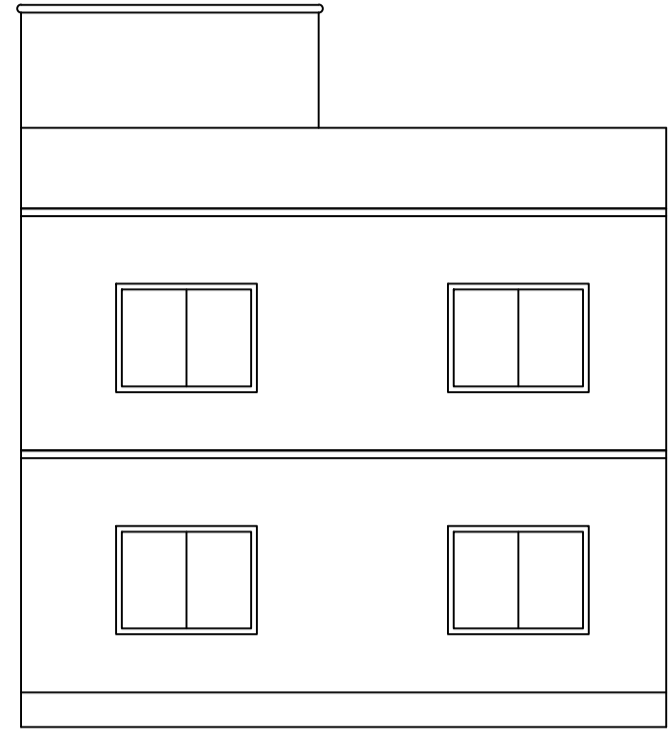

RIGHT SIDE ELEVATION

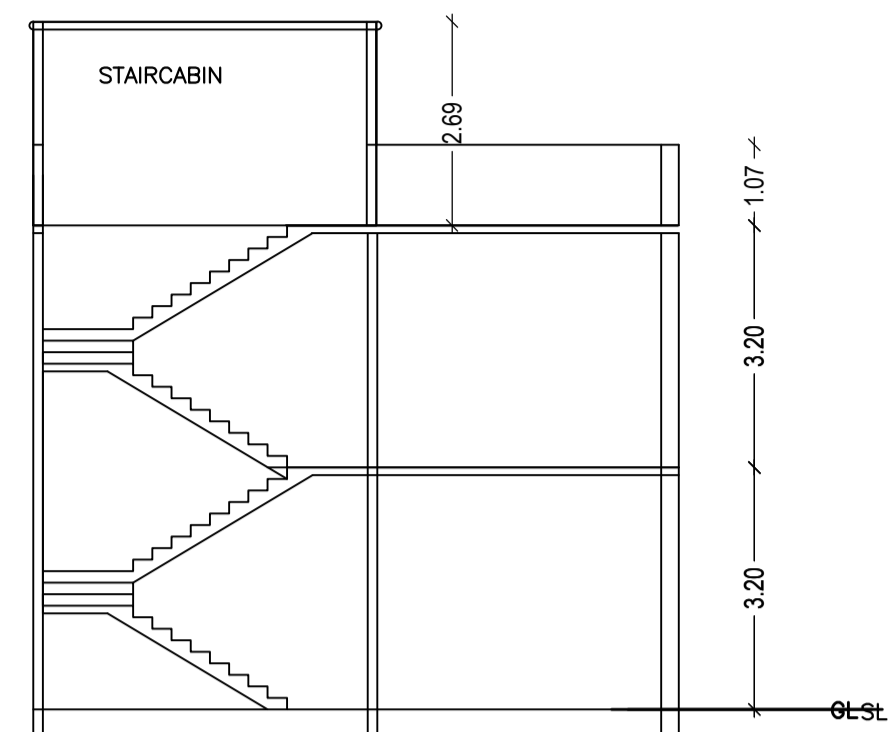

SECTION ON X-X

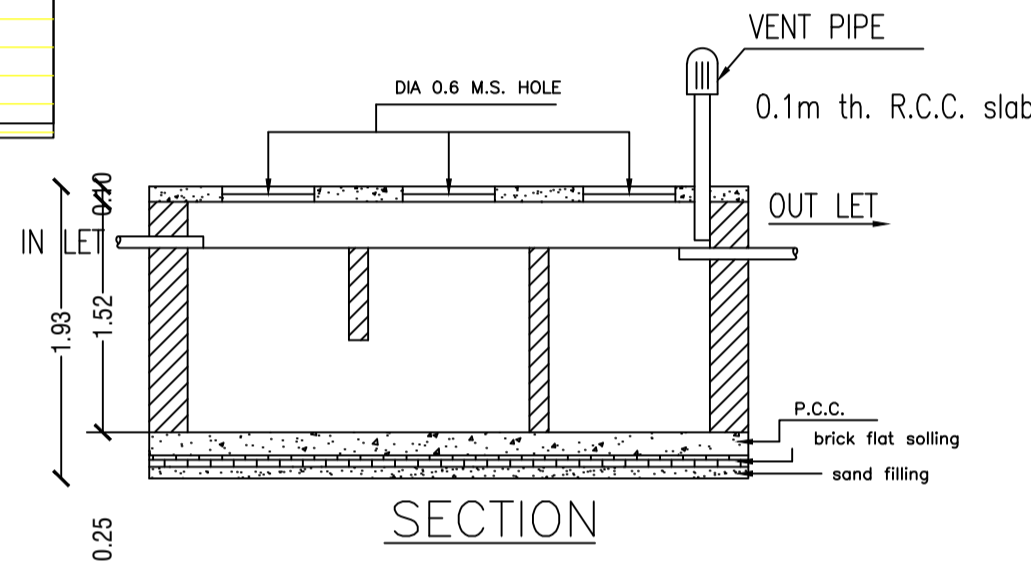

SECTION

DETAILS OF SEPTIC TANK

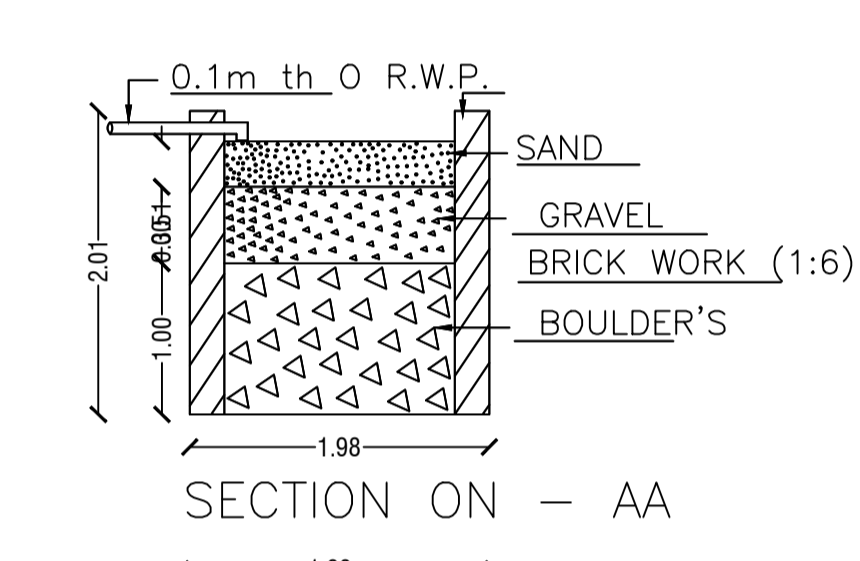

SECTION ON - AA

DETAIL'S OF WATER HARVESTING

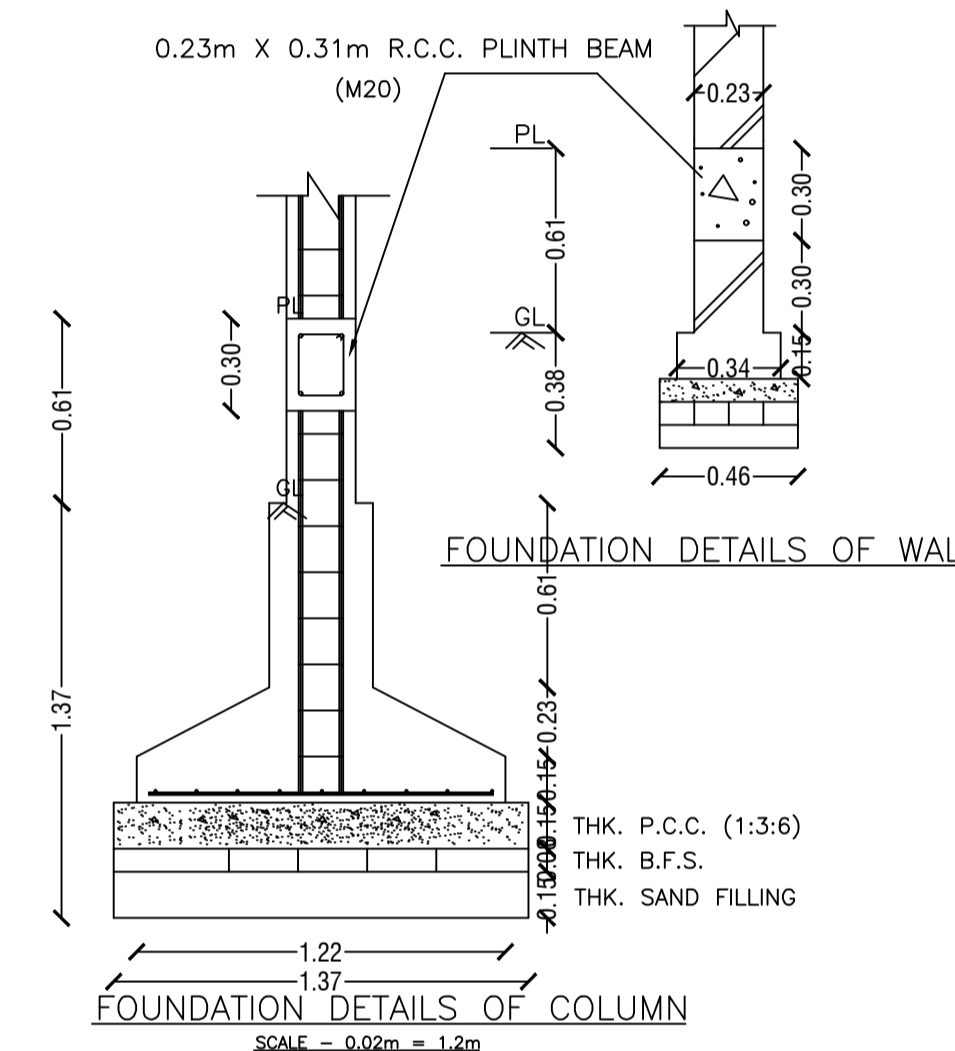

FOUNDATION DETAILS OF COLUMN

Proposal Basic Information	
Proposal File No.	DMC/BP/0081/W20/2018
Owner Name	Sri. Naresh Yadav
Khata No	04
Plot No	97 (P)
Village Name	Bisanpur
Use	Residential
SubUse	Semidetached

AREA STATEMENT		VERSION NO. : 1.0.28
DHANBAD MUNICIPAL CORPORATION		VERSION DATE: 30/06/2018
PROJECT DETAIL:		
Region: JHARKHAND URBAN LOCAL BODIES	Plot Use: Residential	
District: DHANBAD	Plot SubUse: Semidetached	
Authority: DHANBAD MUNICIPAL CORPORATION	PlotNearbyReligiousStructure: NA	
Inward_No: DMC/BP/0081/W20/2018	PlotSubPlot No: 97 (P)	
Application Type: General Proposal	North: Plot No. - Part of This Plot	
Project Type: Building Permission	South: Plot No. - Dhiren Gope & Other's	
Nature of Development: New	East: Plot No. - Plot No. - 71 & 97	
Location of Development Area: Old Area	West: Road Width - 1.828 Mtr. Wide Road	
AREA DETAILS:		
AREA OF PLOT (Minimum)	(A)	SQ.MT. 248.54
Deduction for NetPlot Area		
Surrender Free of Cost		10.14
Total		10.14
NET AREA OF PLOT(Gross Plot Area - Deduction from Gross Plot area)	(A-Deductions)	238.41
Deduction for Balance Plot Area(from Gross Plot Area)		
Surrender Free of Cost		10.14
Common Plot		26.20
Total		36.34
BALANCE AREA OF PLOT(Net Plot Area - Recreational/Amenity space)	(A-Deductions)	212.20
PLOT AREA FOR COVERAGE(Net Plot Area)	(A-Deductions)	238.41
Plot Area for FAR (Net Plot Area + RoadWidening Area)	(A-Deductions)	248.54
COVERAGE CHECK		
Permissible Coverage area (60.00 %)		143.05
Proposed Coverage Area (40.96 %)		97.64
Total Prop. Coverage Area (40.96 %)		97.64
Balance coverage area (19.05 %)		45.41
FAR CHECK		
Firm. FAR Area (1.50)		372.81
Total Perm. FAR area		372.81
Residential FAR		97.65
Proposed FAR Area		106.81
Total Proposed FAR Area		106.81
Consumed FAR (Factor)		0.43
Balance FAR Area		266.00
BUILT UP AREA CHECK		
Total Proposed BuiltUp Area		195.29
ARCHITECT (Regd)		Kumud Kanchan
ENGINEER (Regd)		
SUPERVISOR (Regd)		
OWNER (Regd)		Sri. Naresh Yadav
DEVELOPMENT AUTHORITY		LOCAL BODY

Building USE/SUBUSE Details

Building Name	Building Use	Building SubUse	Building Structure
A (A)	Residential	Residential Bldg/Apartment	Non-Highrise

Building :A (A)

Floor Name	Total Built Up Area (Sq.mt.)	Deductions (Area in Sq.mt.)	Proposed FAR Area (Sq.mt.)	Add Area In FAR (Sq.mt.)	Total FAR Area (Sq.mt.)	Total Consumed Additional FAR Area (Sq.mt.)	Trmt (No.)
Stilt Floor	97.64	88.48	0.00	9.16	9.16	9.16	00
First Floor	97.65	0.00	97.65	0.00	97.65	97.65	01
Terrace Floor	0.00	0.00	0.00	0.00	0.00	0.00	00
Total :	195.29	88.48	97.65	9.16	106.81	106.81	01
Total Number of Same Buildings :	1						
Total :	195.29	88.48	97.65	9.16	106.81	106.81	01

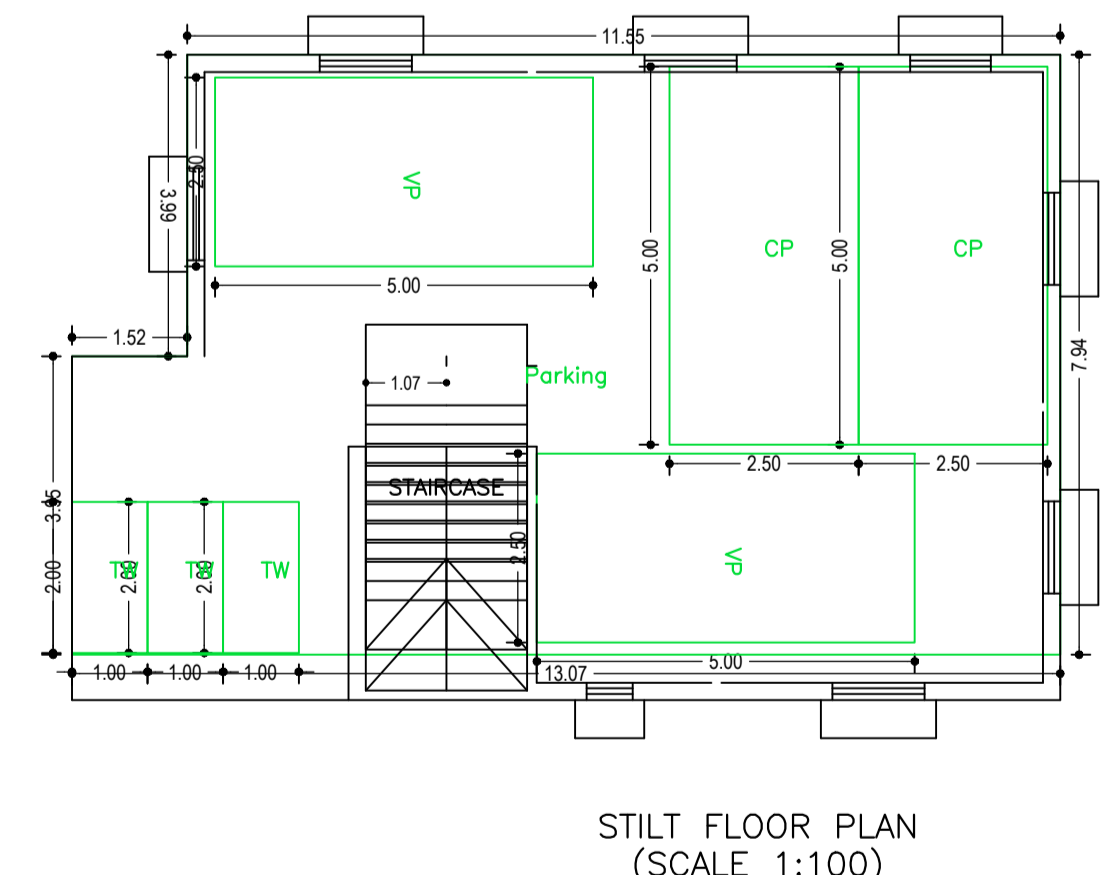

STILT FLOOR PLAN (SCALE 1:100)

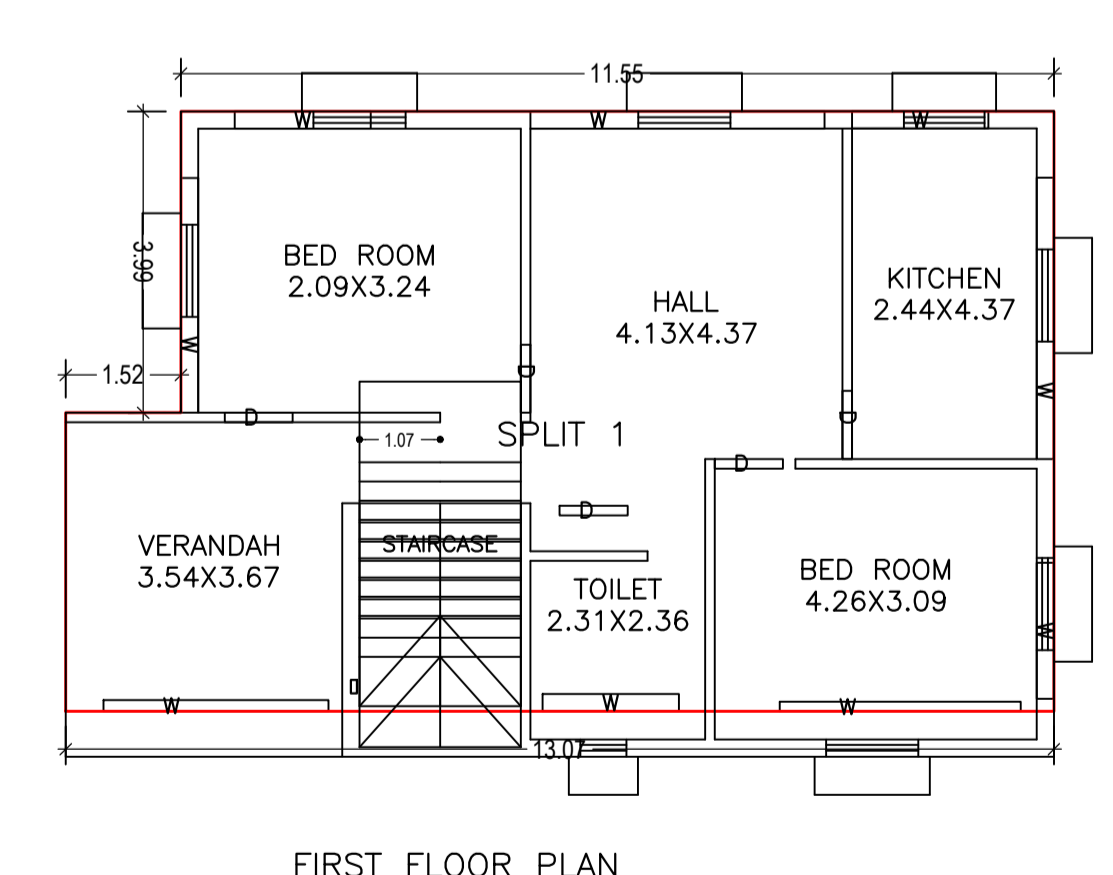

FIRST FLOOR PLAN (Proposed) (SCALE 1:100)

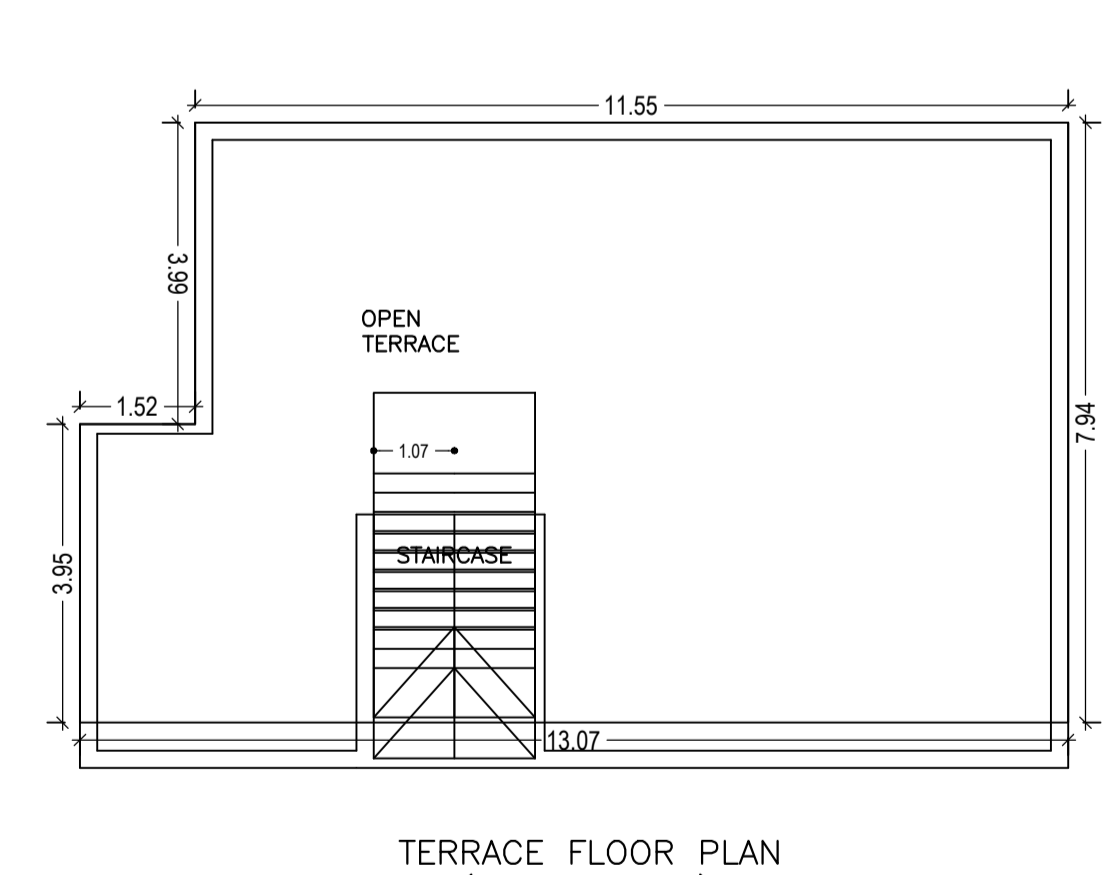

TERRACE FLOOR PLAN (SCALE 1:100)

SCHEDULE OF DOOR:

BUILDING NAME	NAME	LENGTH	HEIGHT	NOS
A (A)	D	0.90	2.10	05

SCHEDULE OF WINDOW/VENTILATION:

BUILDING NAME	NAME	LENGTH	HEIGHT	NOS
A (A)	W		1.20	04
A (A)	W	2.98		01
A (A)	W	3.11	1.20	01
A (A)	W		1.20	01
A (A)	W	3.72	1.20	01
A (A)	W	3.89		01

FAR & Tenement Details (Table 4c-1)

Building	No. of Same Bldg	Total Built Up Area (Sq.mt.)	Deductions (Area in Sq.mt.)	Proposed FAR Area (Sq.mt.)	Add Area In FAR (Sq.mt.)	Total FAR Area (Sq.mt.)	Total Consumed Additional FAR Area (Sq.mt.)	Trmt (No.)
A (A)	1	195.29	88.48	97.65	9.16	106.81	106.81	01
Grand Total :	1	195.29	88.48	97.65	9.16	106.81	106.81	01

COLOR INDEX	
PLOT BOUNDARY	Black
ABUTTING ROAD	Red
PROPOSED CONSTRUCTION	Green
COMMON PLOT	Yellow
ROAD WIDENING AREA	Blue
EXISTING (To be retained)	Grey
EXISTING (To be demolished)	White

Buildingwise Floor FAR Details

Floor Name	Building Name		Total	
	Proposed Built Up Area (Sq.mt.)	Proposed FAR Area (Sq.mt.)	Total Proposed Built Up Area (Sq.mt.)	Total FAR Area (Sq.mt.)
Stilt Floor	97.64	9.16	97.64	9.16
First Floor	97.65	97.65	97.65	97.65
Terrace Floor	0.00	0.00	0.00	0.00
Total :	195.29	106.81	195.29	106.81

UnitBUA Table for Building :A (A)

FLOOR	Name	UnitBUA Type	UnitBUA Area	Carpet Area	No. of Rooms	No. of Tenement
FIRST FLOOR PLAN	SPLIT 1	FLAT	97.65	97.63	6	1
Total:	-	-	97.65	97.63	6	1

LTP NAME AND SIGNATURE	STRUCTURAL ENG'S NAME AND SIGNATURE	BUILDER NAME AND SIGNATURE
Kumud Kanchan DMC/ARC/0002/2016		

Proposal Basic Information

Proposal File No.	DMC/BP/0081/W20/2018
Owner Name	Sri. Naresh Yadav
Khata No	04
Plot No	97 (P)
Village Name	Bisanpur
Use	Residential
SubUse	Semidetached

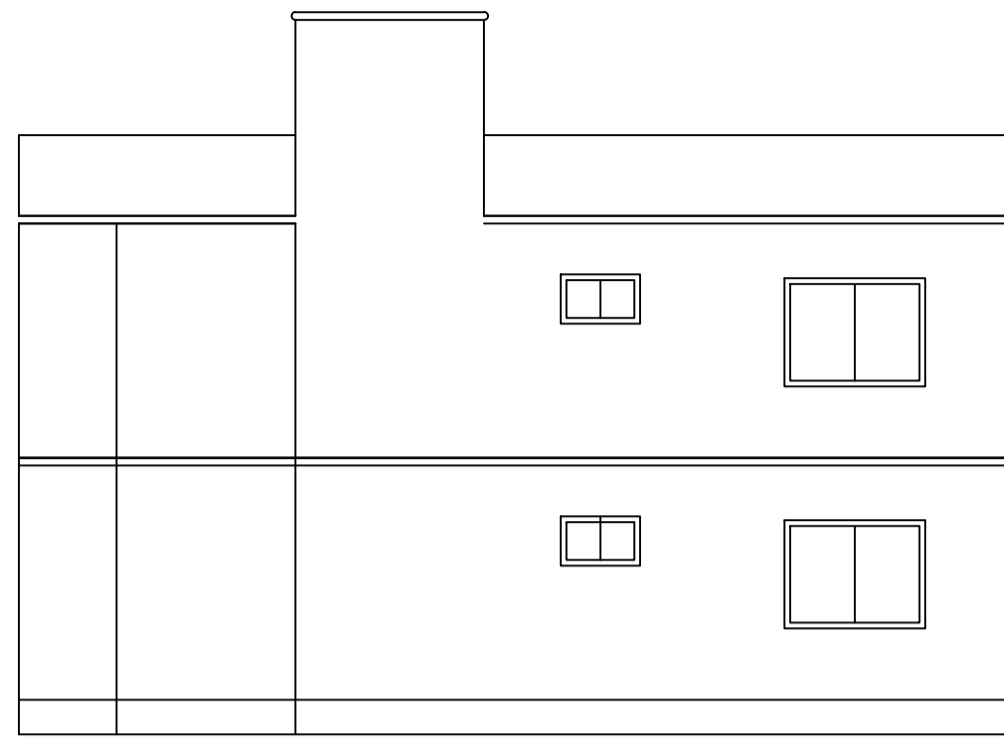

FRONT ELEVATION

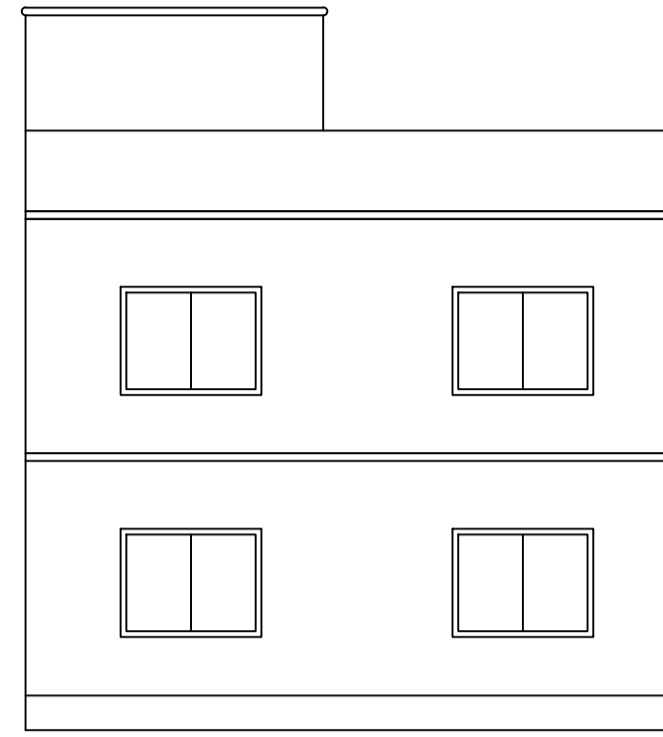

RIGHT SIDE ELEVATION

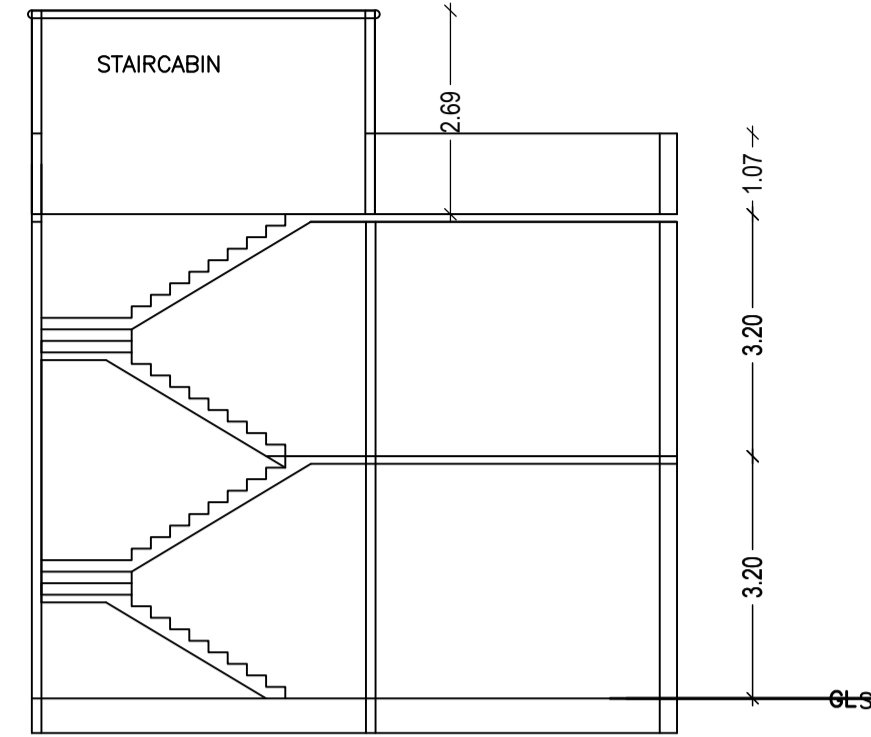

SECTION ON X-X

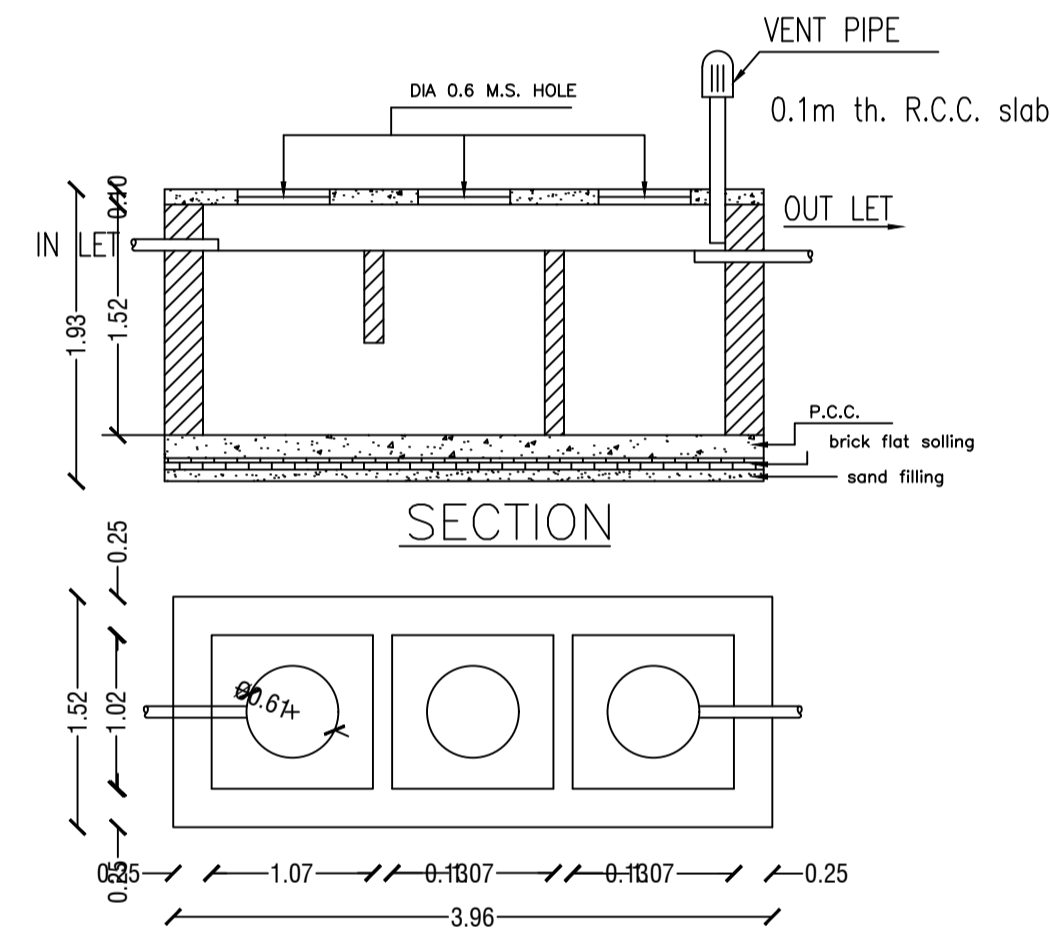
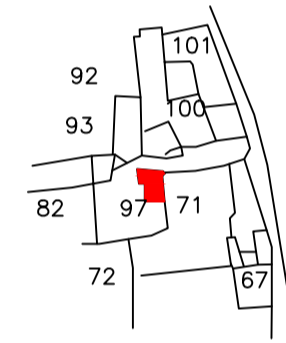

DETAILS OF SEPTIC TANK

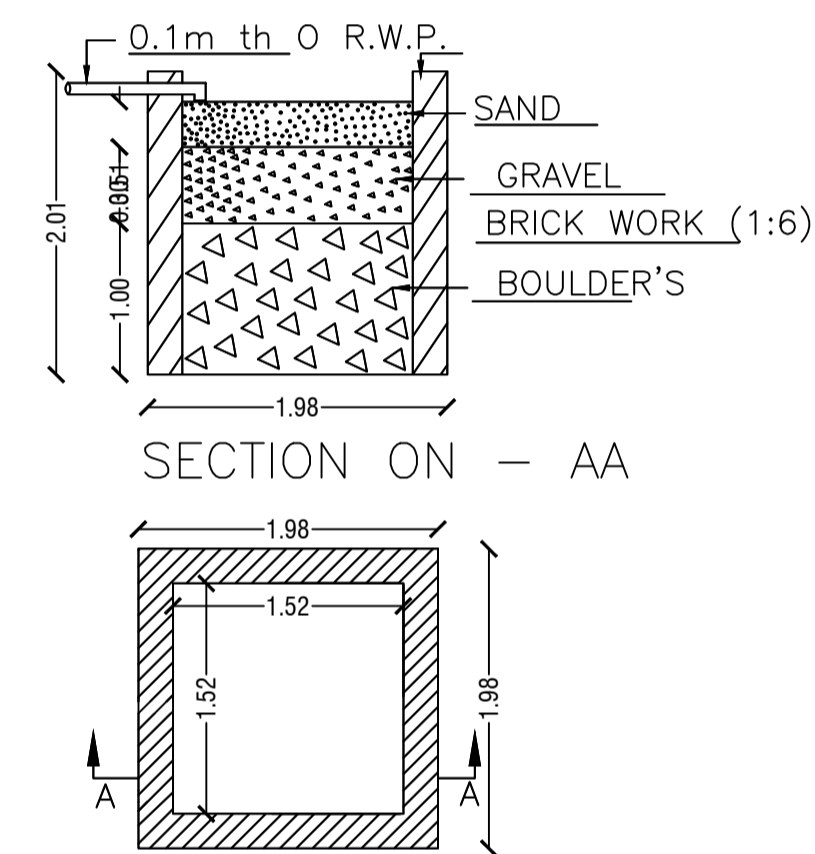

DETAIL'S OF WATER HARVESTING

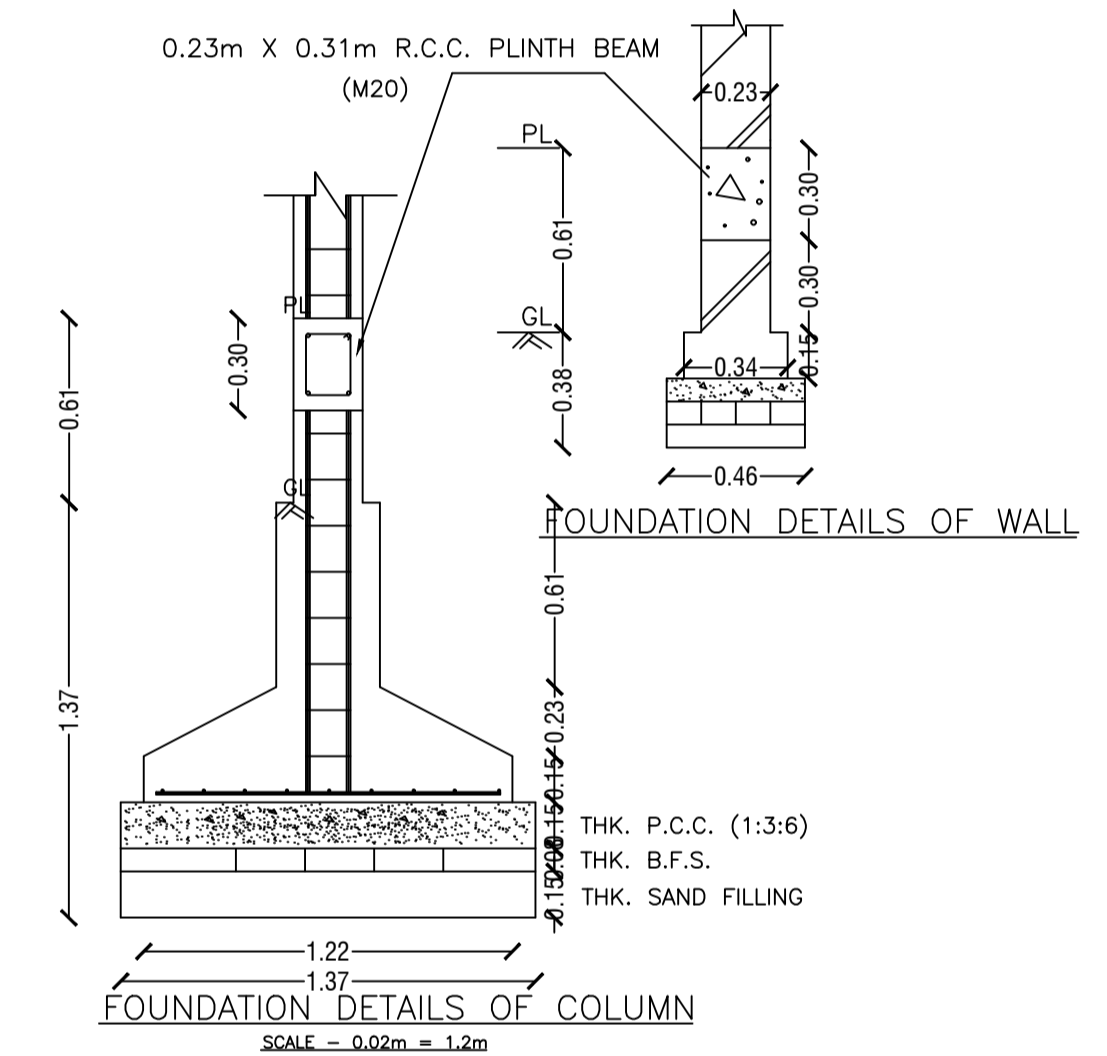

FOUNDATION DETAILS OF COLUMN
SCALE - 0.02m = 1.2m

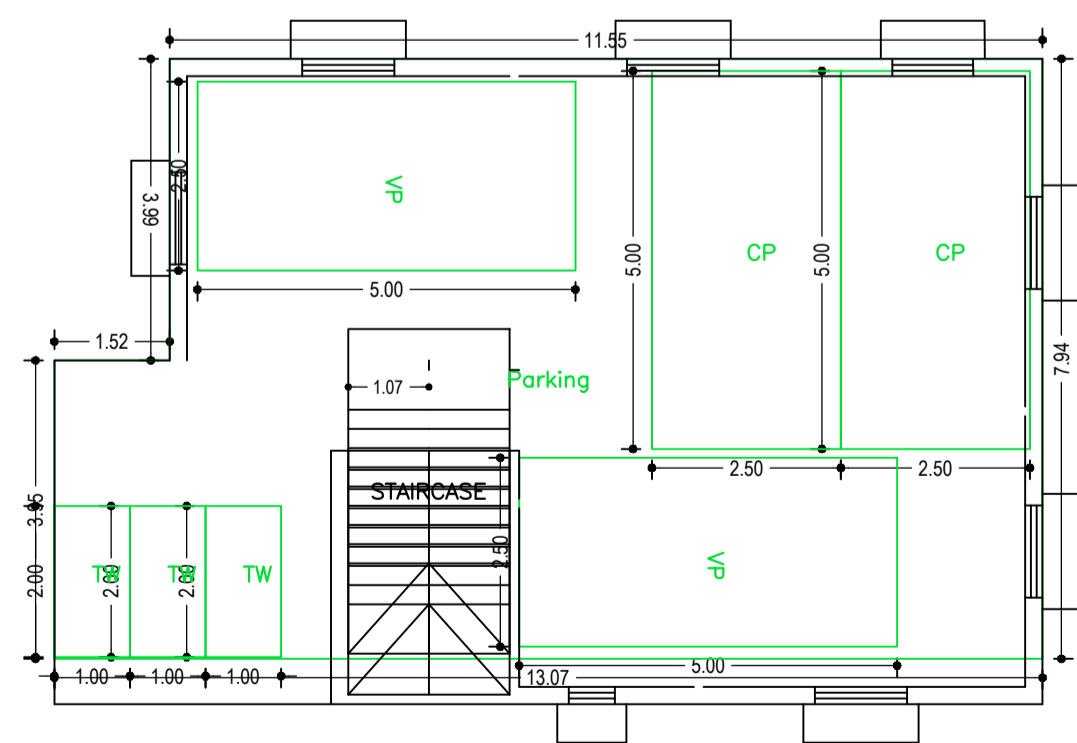

STILT FLOOR PLAN
(SCALE 1:100)

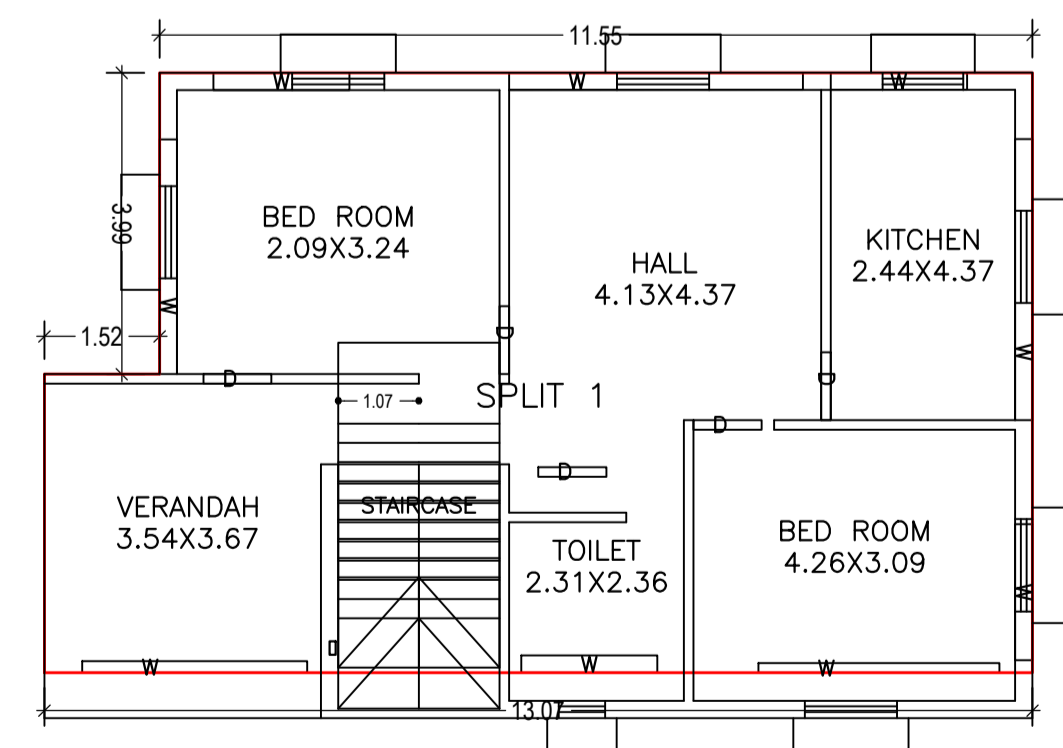

FIRST FLOOR PLAN
(Proposed)
(SCALE 1:100)

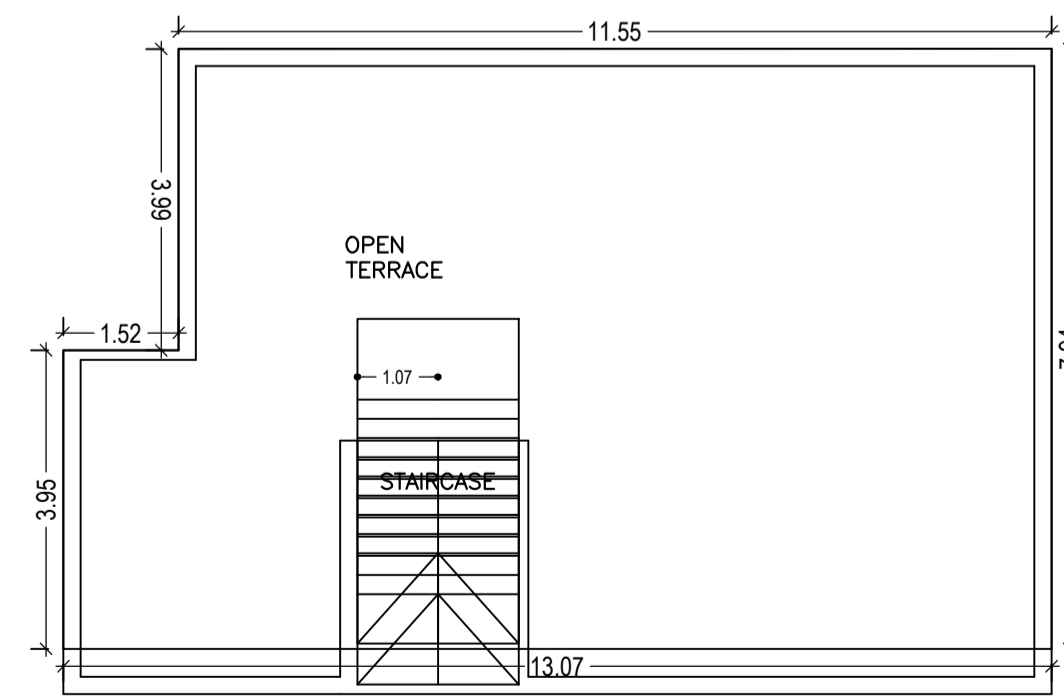

TERRACE FLOOR PLAN
(SCALE 1:100)

LTP NAME AND SIGNATURE Kumud Kanchan DMC/ARC/0002/2016	STRUCTURAL ENG'S NAME AND SIGNATURE	BUILDER NAME AND SIGNATURE
--	-------------------------------------	----------------------------