

SITE PLAN

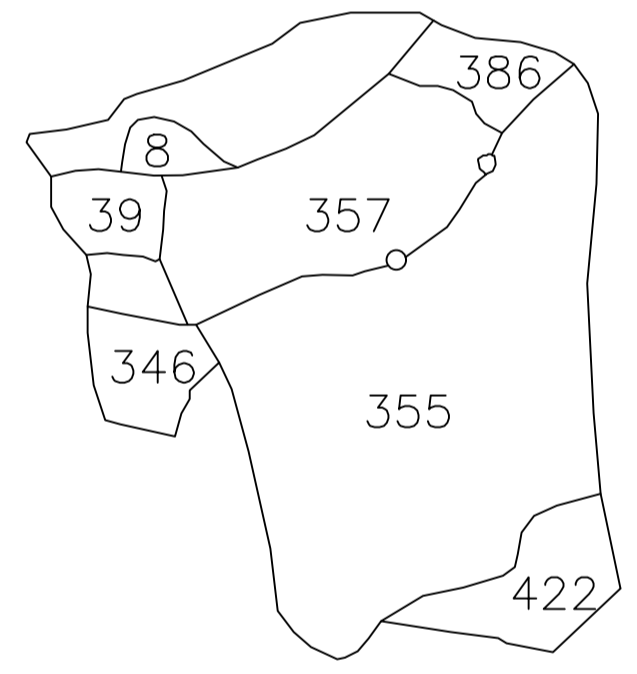

KEY PLAN
NOT TO SCALE

Building USE/SUBUSE Details

Building Name	Building Use	Building SubUse	Building Structure
A (A)	Residential	Residential Bldg/Apartment	Non-Highrise

SCHEDULE OF DOOR:

BUILDING NAME	NAME	LENGTH	HEIGHT	NOS
A (A)	D1	0.90	2.10	10
A (A)	D	1.05	2.10	10
A (A)	D	1.06	2.10	02
A (A)	CG	3.23	2.10	02

SCHEDULE OF WINDOW/VENTILATION:

BUILDING NAME	NAME	LENGTH	HEIGHT	NOS
A (A)	V	0.60	1.20	04
A (A)	G	0.90	1.20	02
A (A)	W1	1.50	1.20	22
A (A)	W	2.60	1.20	02

Building :A (A)

Floor Name	Total Built Up Area (Sq.mt.)	Proposed FAR Area (Sq.mt.)	Total FAR Area (Sq.mt.)	Total Consumed Additional FAR Area (Sq.mt.)	Tnmt (No.)
Ground Floor	133.41	133.41	133.41	133.41	01
First Floor	133.41	133.41	133.41	133.41	00
Terrace Floor	0.00	0.00	0.00	0.00	00
Total :	266.82	266.82	266.82	266.82	01
Total Number of Same Buildings	1				
Total :	266.82	266.82	266.82	266.82	01

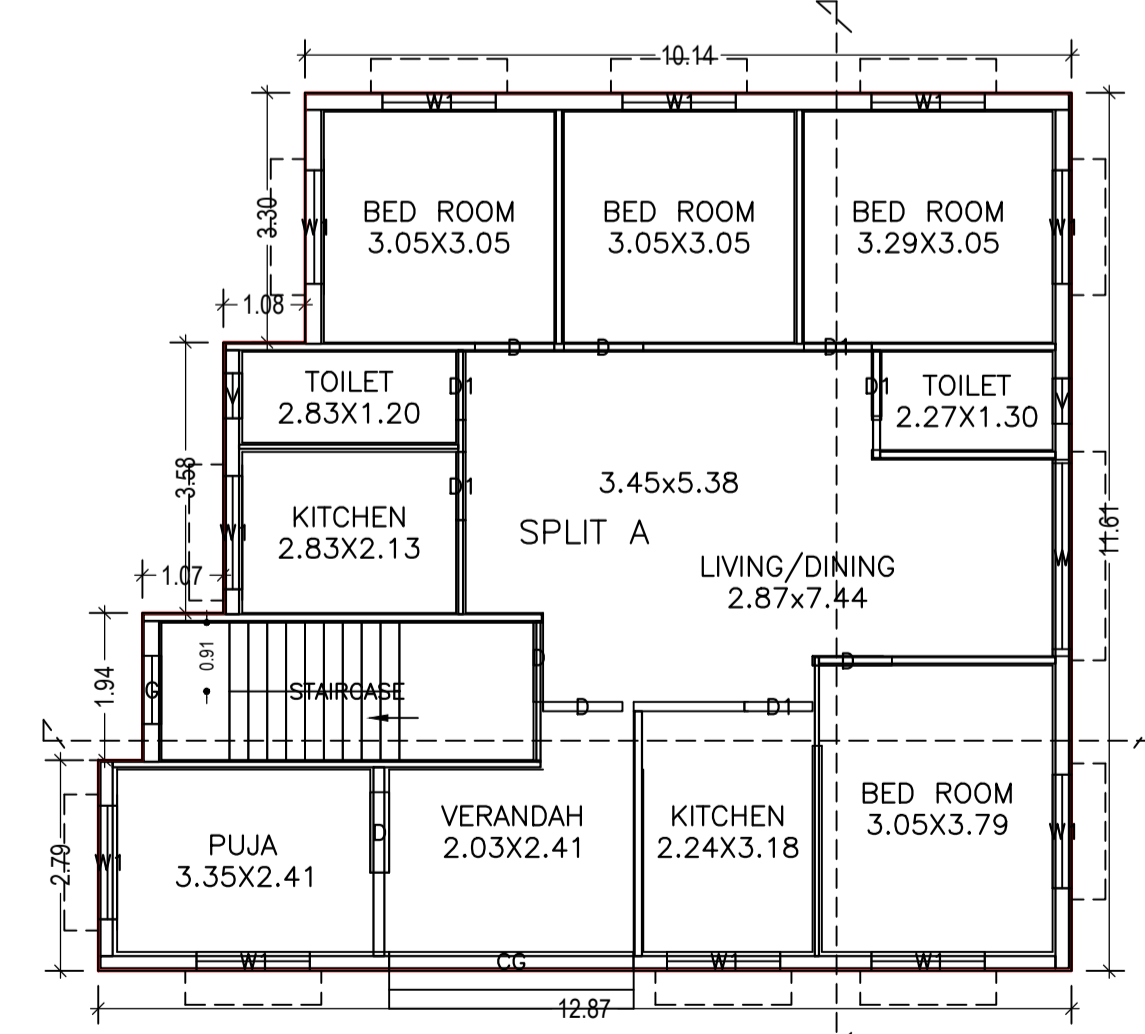

GROUND FLOOR PLAN
(Proposed)
(SCALE 1:100)

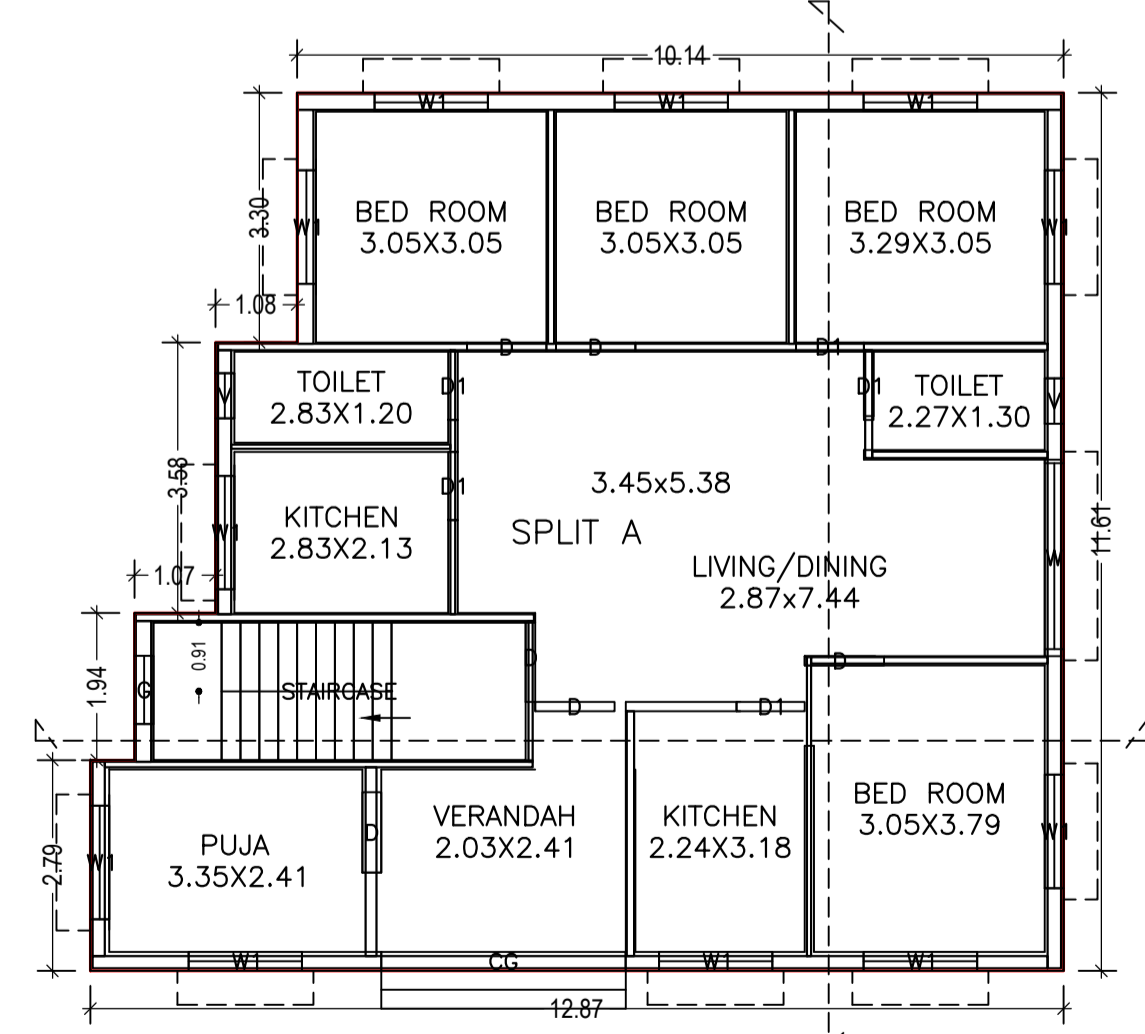

FIRST FLOOR PLAN
(Proposed)
(SCALE 1:100)

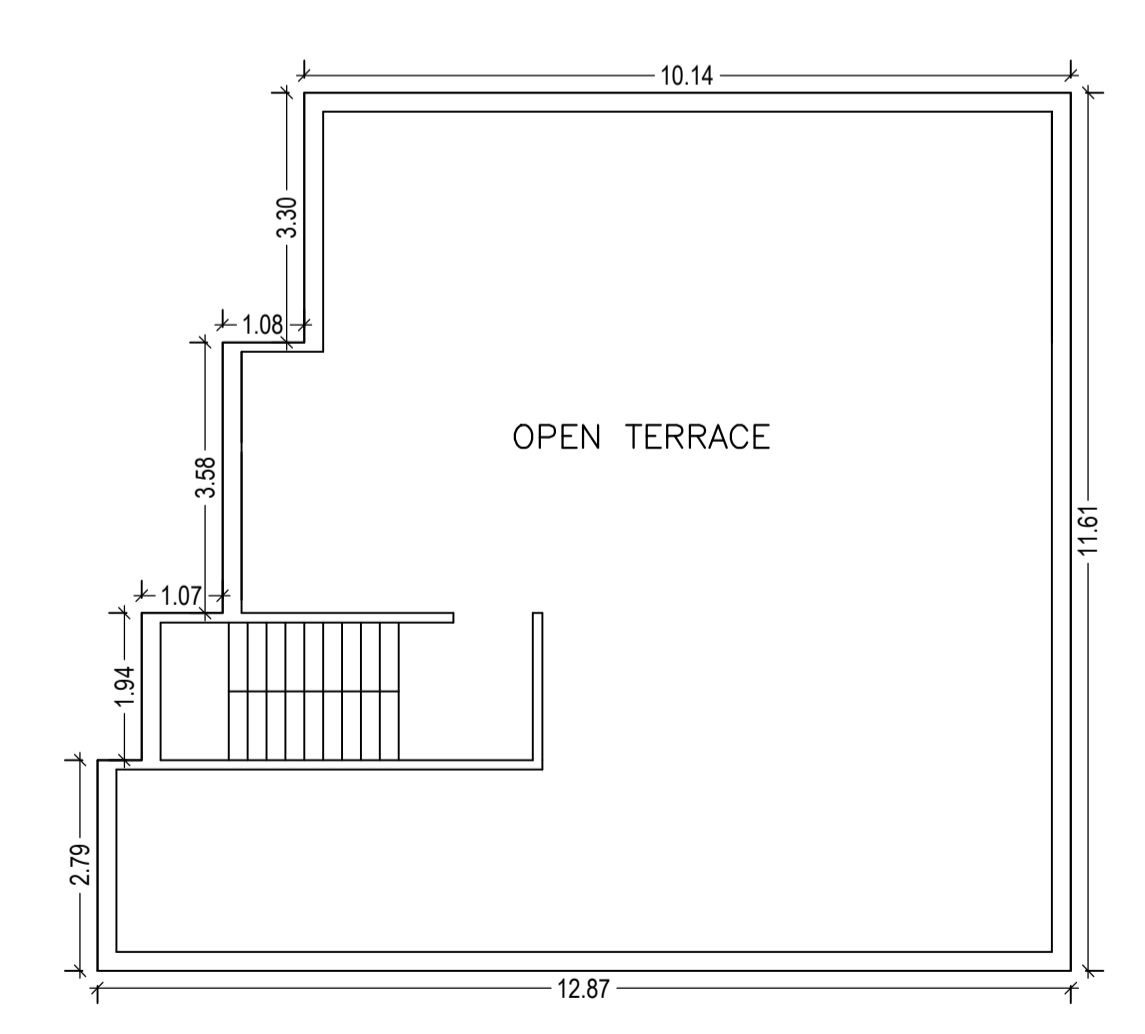

TERRACE FLOOR PLAN
(SCALE 1:100)



FRONT ELEVATION

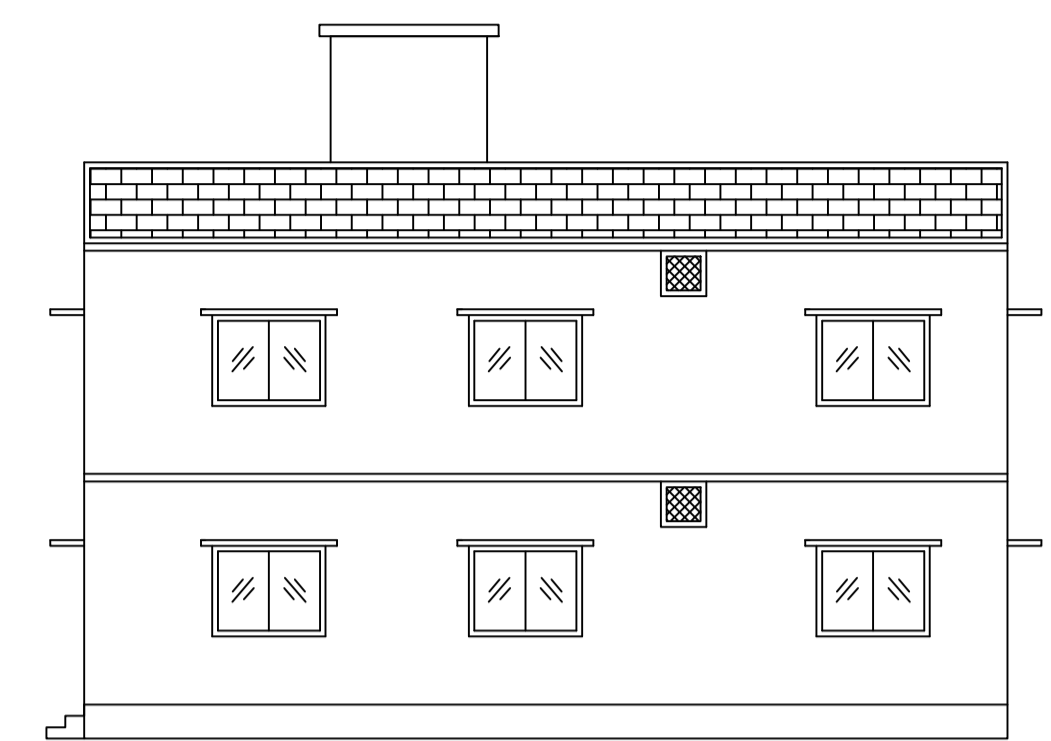

RIGHT SIDE ELEVATION

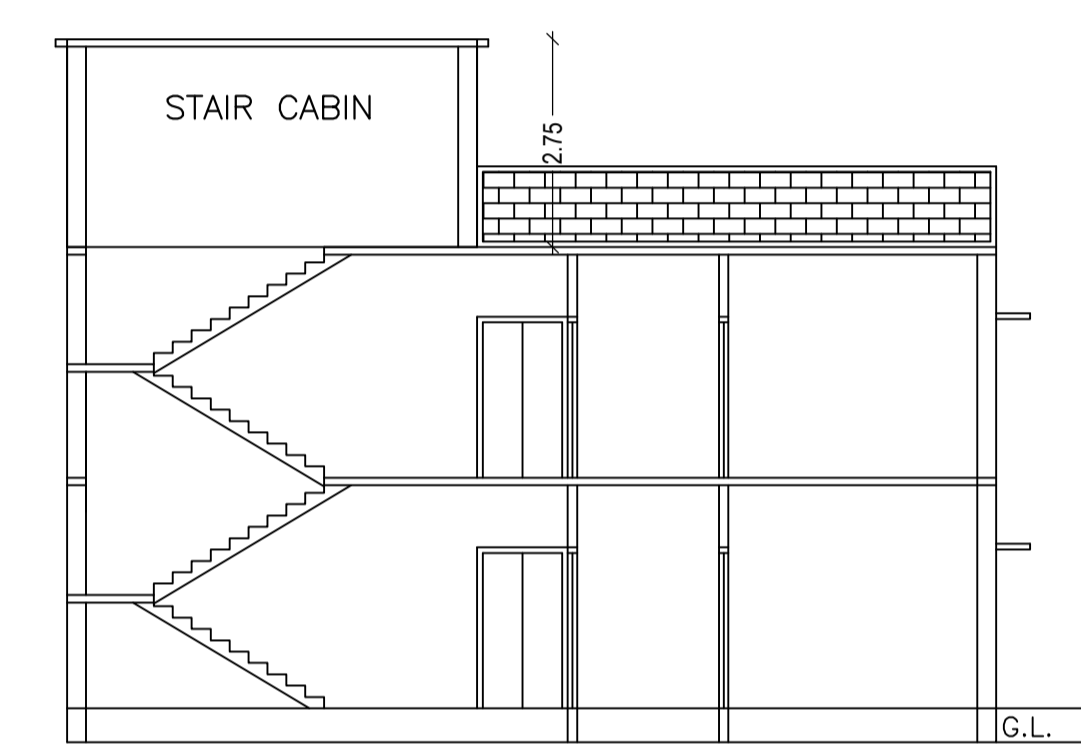

SECTION ON X-X

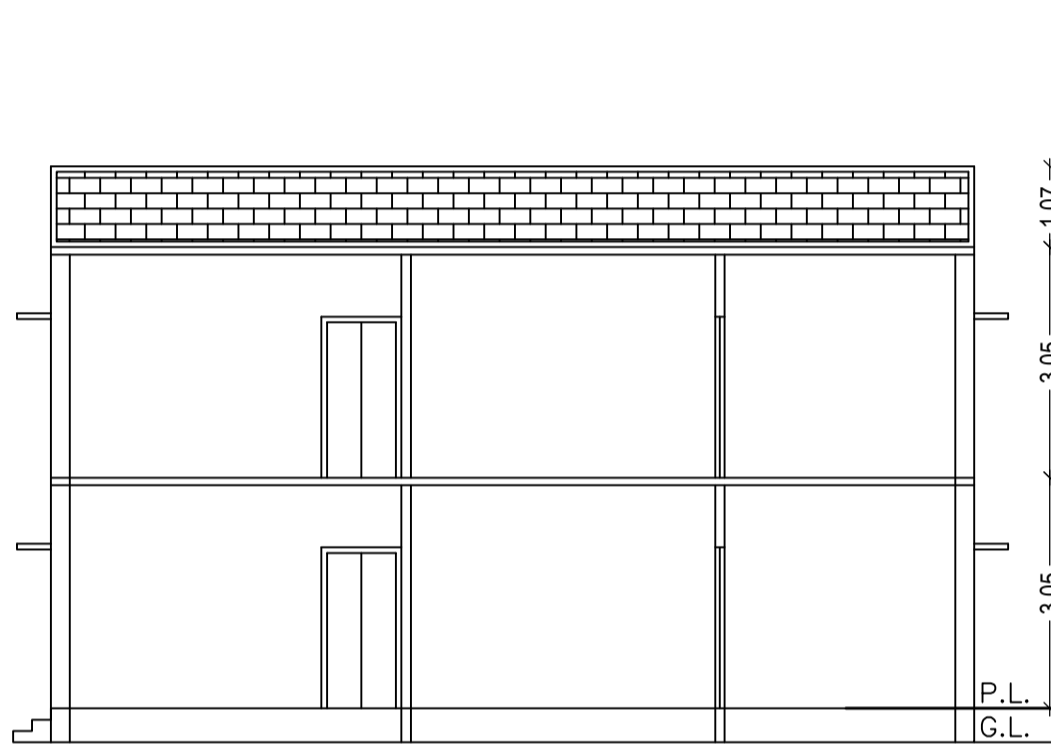

SECTION ON Y-Y

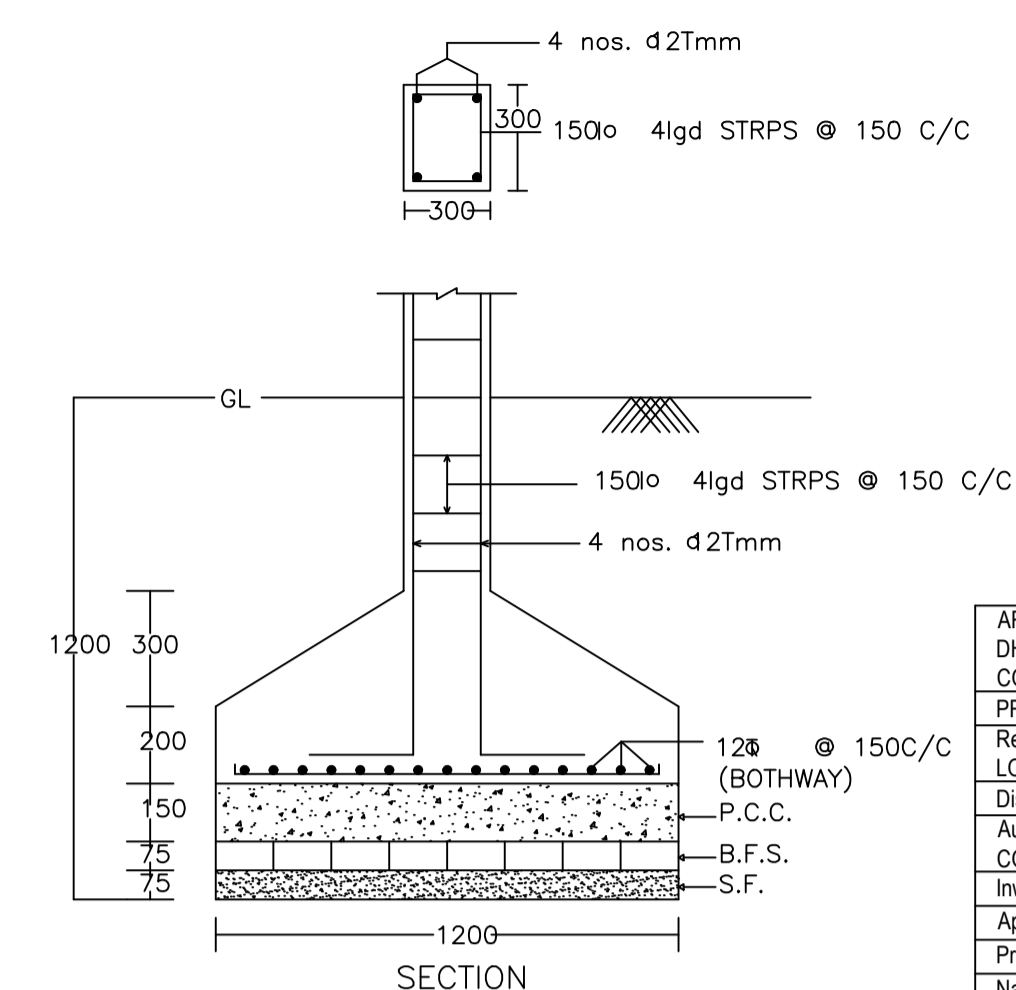

SECTION

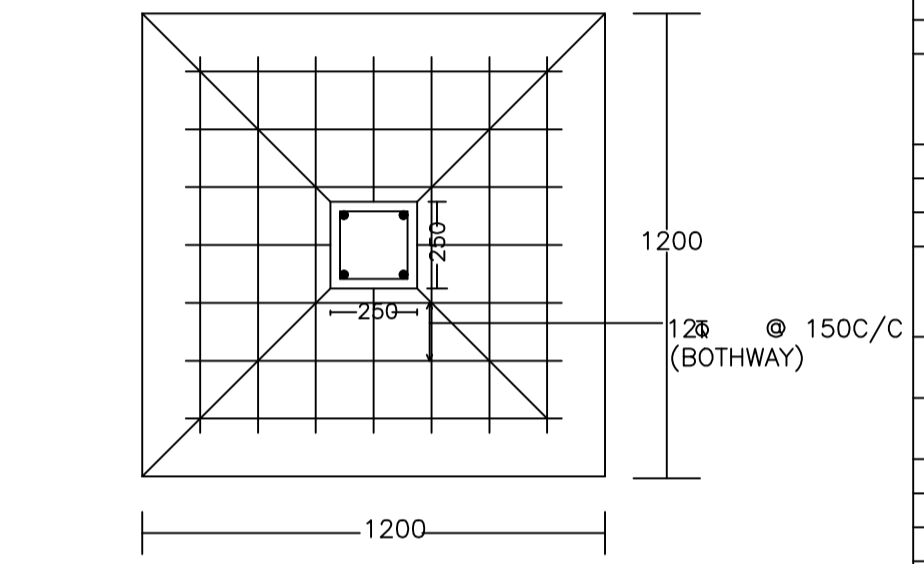

PLAN
DETAIL OF COLUMNS

Proposal Basic Information

Proposal File No.	DMC/BP/0090/W20/2018
Owner Name	SUSHILA DEVI
Khata No	26 , NEW - 261
Plot No	357 , NEW - 711
Village Name	Bisanpur
Use	Residential
SubUse	Residential Bldg/Apartment

AREA STATEMENT	VERSION NO. : 1.0.28
DHANBAD MUNICIPAL CORPORATION	VERSION DATE: 30/06/2018
PROJECT DETAIL:	
Region: JHARKHAND URBAN LOCAL BODIES	Plot Use: Residential
District: DHANBAD CORPORATION	Plot SubUse: Residential Bldg/Apartment
Authority: DHANBAD MUNICIPAL CORPORATION	PlotNearby/ReligiousStructure: NA
Inward No: DMC/BP/0090/W20/2018	Plot/SubPlot No: 357 , NEW - 711
Application Type: General Proposal	North: Plot No. - VACCANT LAND
Project Type: Building Permission	South: Plot No. - SUDHA DEVI
Nature of Development: New	East: Plot No. - SARITA DEVI & BAHADUR
Location of Development Area: Old Area	West: Road Width - 3.65 M WIDE ROAD
AREA DETAILS:	
AREA OF PLOT (Minimum)	(A)
NET AREA OF PLOT(Gross Plot Area - Deduction from Gross Plot area)	(A-Deductions)
Deduction for Balance Plot Area(from Gross Plot Area)	
Common Plot	49.05
Total	49.05
BALANCE AREA OF PLOT(Net Plot Area - Recreational/Amenity spaces)	(A-Deductions)
PLOT AREA FOR COVERAGE(Net Plot Area)	(A-Deductions)
Plot Area for FAR (Net Plot Area + RoadWidening Area)	(A-Deductions)
COVERAGE CHECK	
Permissible Coverage area (70.00 %)	157.45
Proposed Coverage Area (59.31 %)	133.41
Total Prop. Coverage Area (59.31 %)	133.41
Balance coverage area (10.69 %)	24.04
FAR CHECK	
Perm. FAR Area (1.50)	337.39
Total Perm. FAR area	337.39
Residential FAR	266.82
Proposed FAR Area	266.82
Total Proposed FAR Area	266.82
Consumed FAR (Factor)	1.19
Balance FAR Area	70.57
BUILT UP AREA CHECK	
Total Proposed BuiltUp Area	266.82
ARCHITECT (Regd)	AMARENDRA KUMAR
ENGINEER (Regd)	
SUPERVISOR (Regd)	
OWNER (Regd)	SUSHILA DEVI
DEVELOPMENT AUTHORITY	
	LOCAL BODY

COLOR INDEX	
PLOT BOUNDARY	Black
ABUTTING ROAD	Green
PROPOSED CONSTRUCTION	Red
COMMON PLOT	Yellow
ROAD WIDENING AREA	Orange
EXISTING (To be retained)	Blue
EXISTING (To be demolished)	White

Buildingwise Floor FAR Details

Floor Name	Building Name A (A)		Total	
	Proposed Built Up Area (Sq.mt.)	Proposed FAR Area (Sq.mt.)	Total Proposed Built Up Area (Sq.mt.)	Total FAR Area (Sq.mt.)
Ground Floor	133.41	133.41	133.41	133.41
First Floor	133.41	133.41	133.41	133.41
Terrace Floor	0.00	0.00	0.00	0.00
Total :	266.82	266.82	266.82	266.82

FAR & Tenement Details (Table 4c-1)

Building	No. of Same Bldg	Total Built Up Area (Sq.mt.)	Proposed FAR Area (Sq.mt.)	Total FAR Area (Sq.mt.)	Total Consumed Additional FAR Area (Sq.mt.)	Tnmt (No.)
A (A)	1	266.82	266.82	266.82	266.82	01
Grand Total :	1	266.82	266.82	266.82	266.82	01

UnitBUA Table for Building :A (A)

FLOOR	Name	UnitBUA Type	UnitBUA Area	Carpet Area	No. of Rooms	No. of Tenement
GROUND FLOOR PLAN	SPLIT A	FLAT	266.82	242.00	11	1
FIRST FLOOR PLAN	SPLIT A	FLAT	0.00	0.00	11	0
Total:	-	-	266.82	242.00	22	1

LTP NAME AND SIGNATURE	STRUCTURAL ENG'S NAME AND SIGNATURE	BUILDER NAME AND SIGNATURE
AMARENDRA KUMAR DMC/ENG/0009/2016		

Proposal Basic Information	
Proposal File No.	DMC/BP/0090/W20/2018
Owner Name	SUSHILA DEVI
Khata No	26 , NEW - 261
Plot No	357 , NEW - 711
Village Name	Bisanpur
Use	Residential
SubUse	Residential Bldg/Apartment

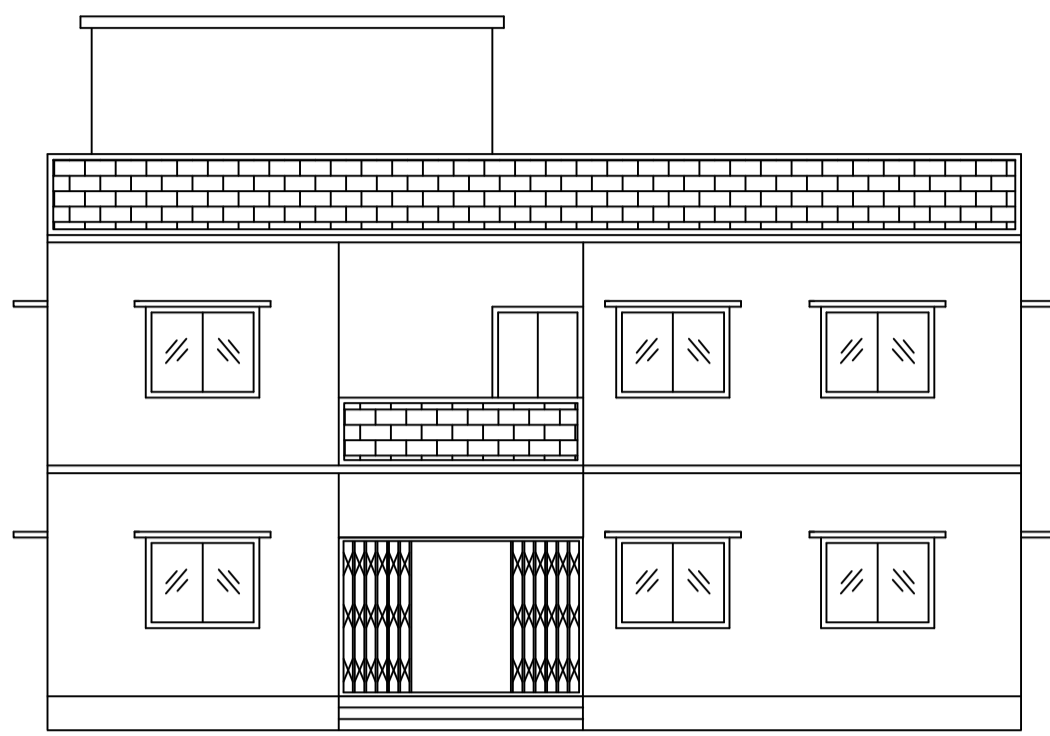

FRONT ELEVATION

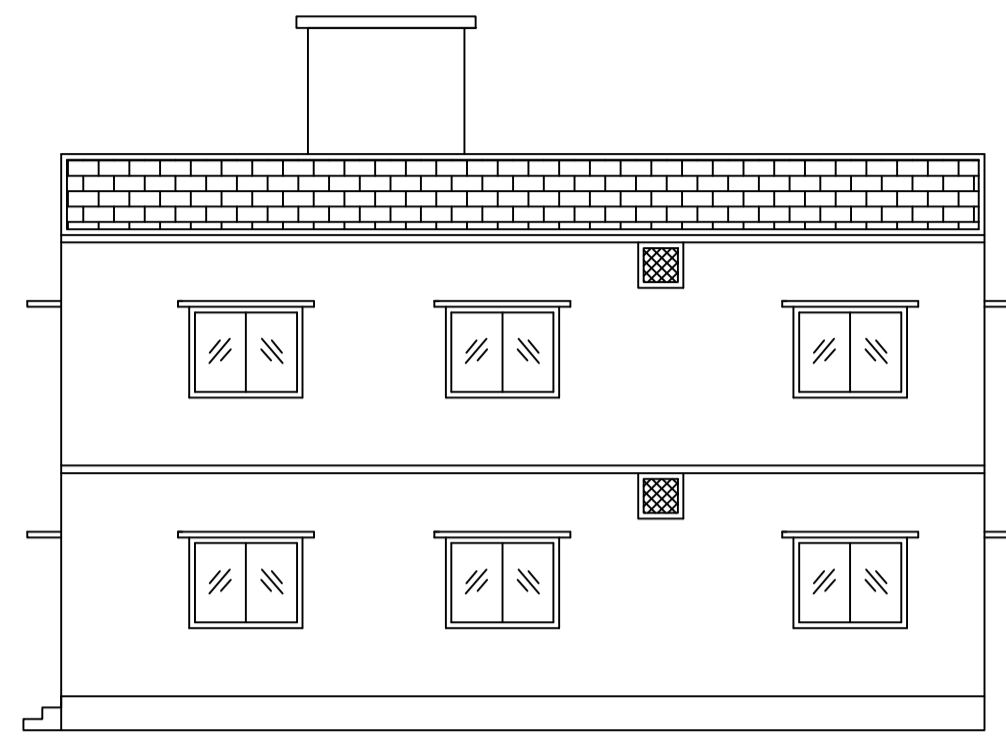

RIGHT SIDE ELEVATION

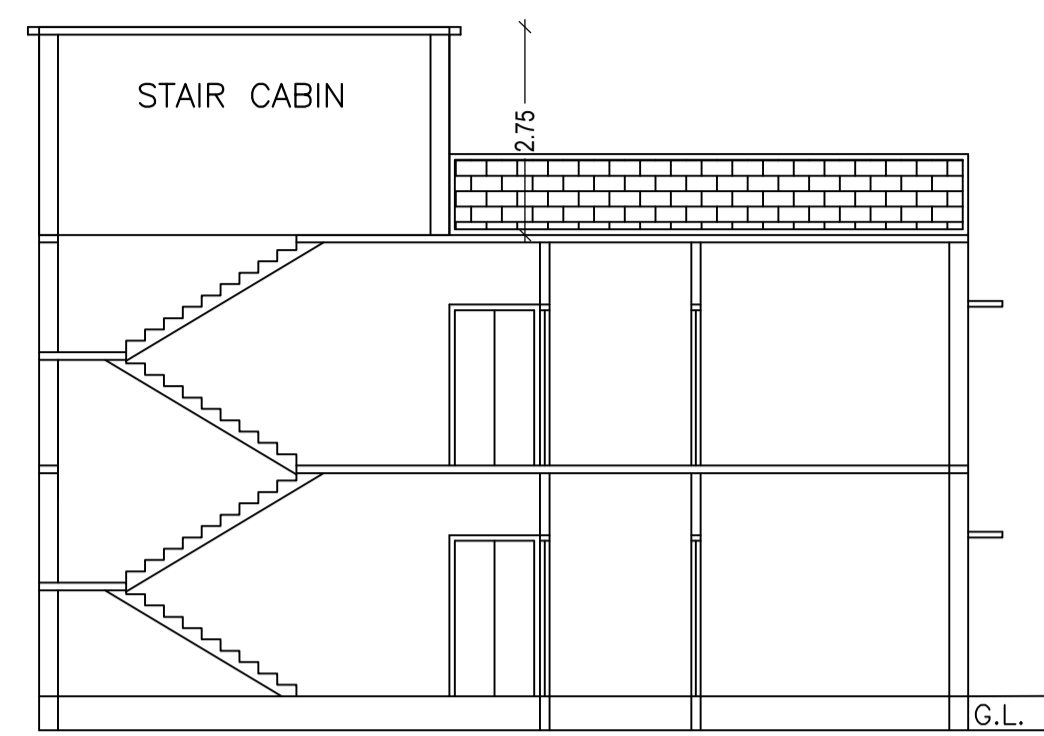

SECTION ON X-X

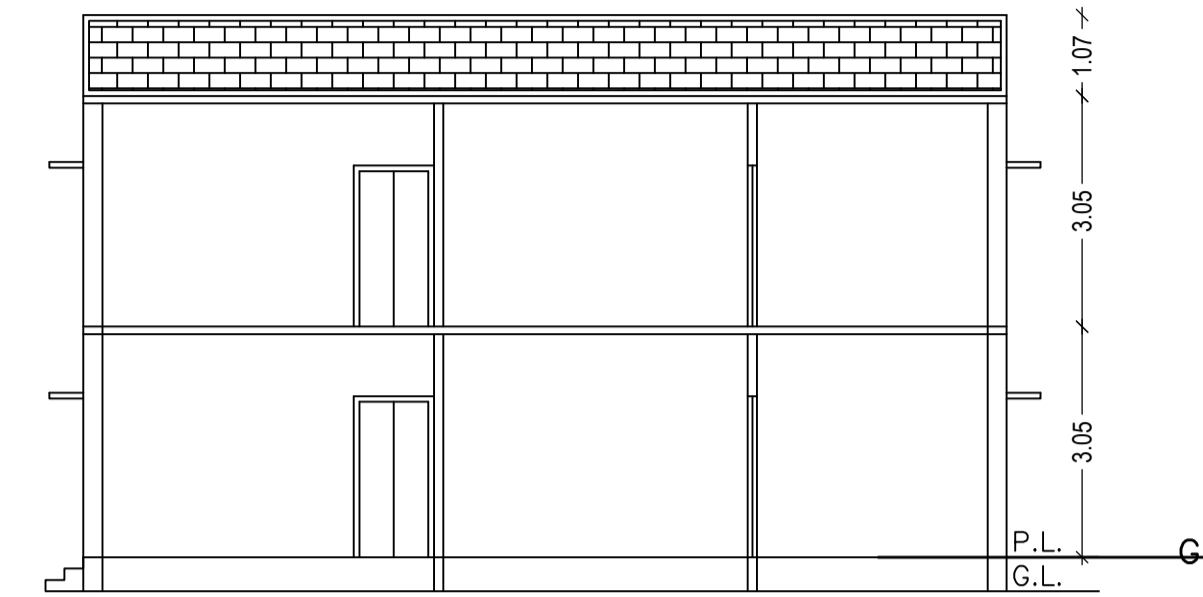

SECTION ON Y-Y

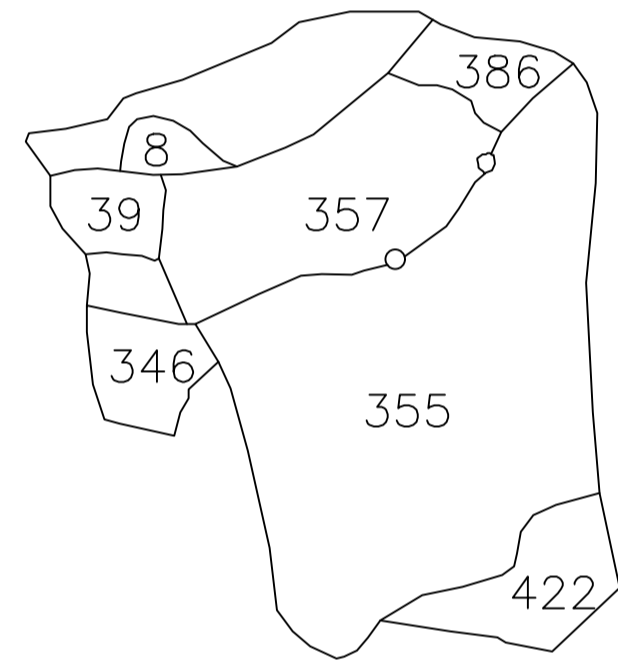

KEY PLAN
NOT TO SCALE

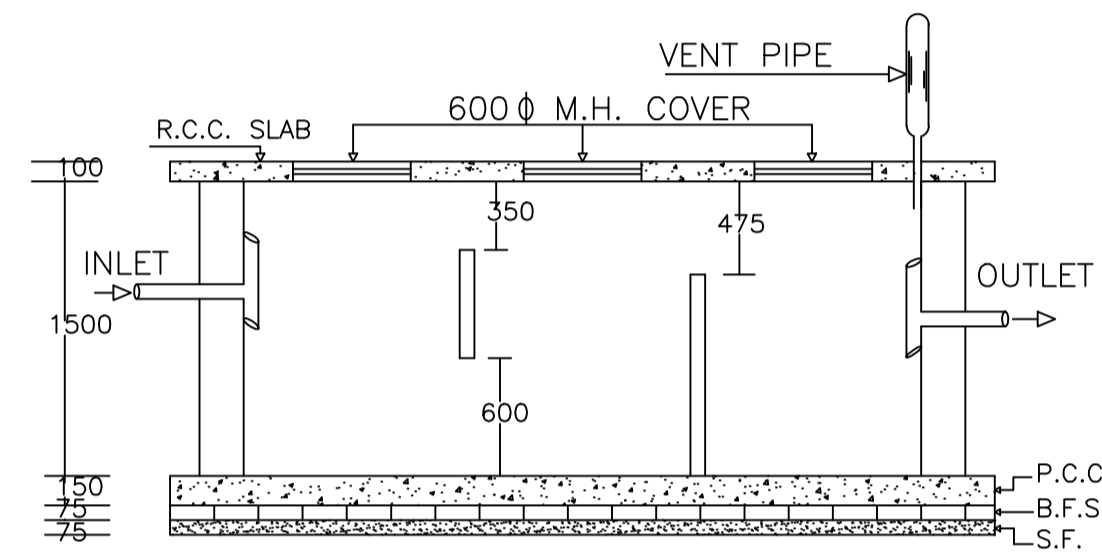

PLAN OF SEPTIC TANK

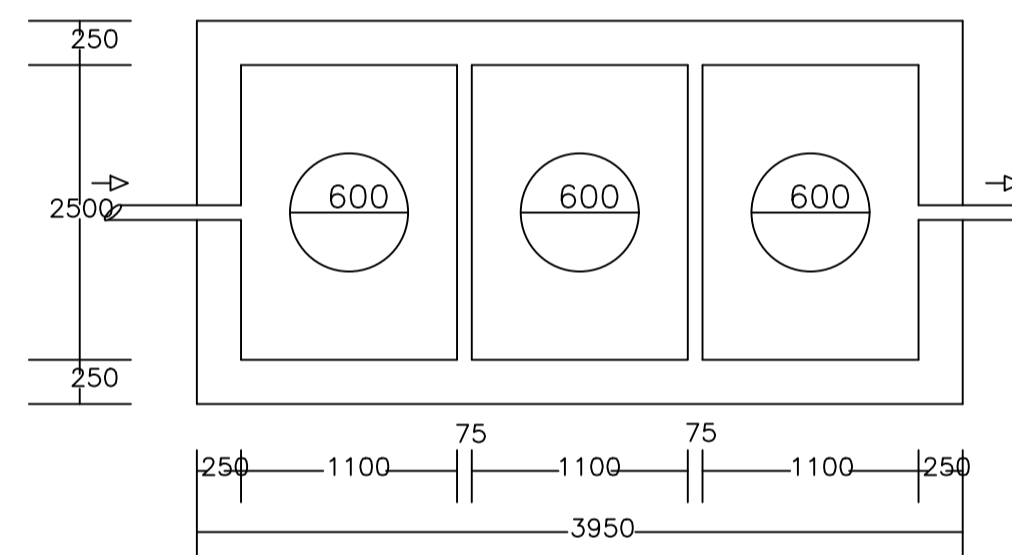

PLAN OF SEPTIC TANK

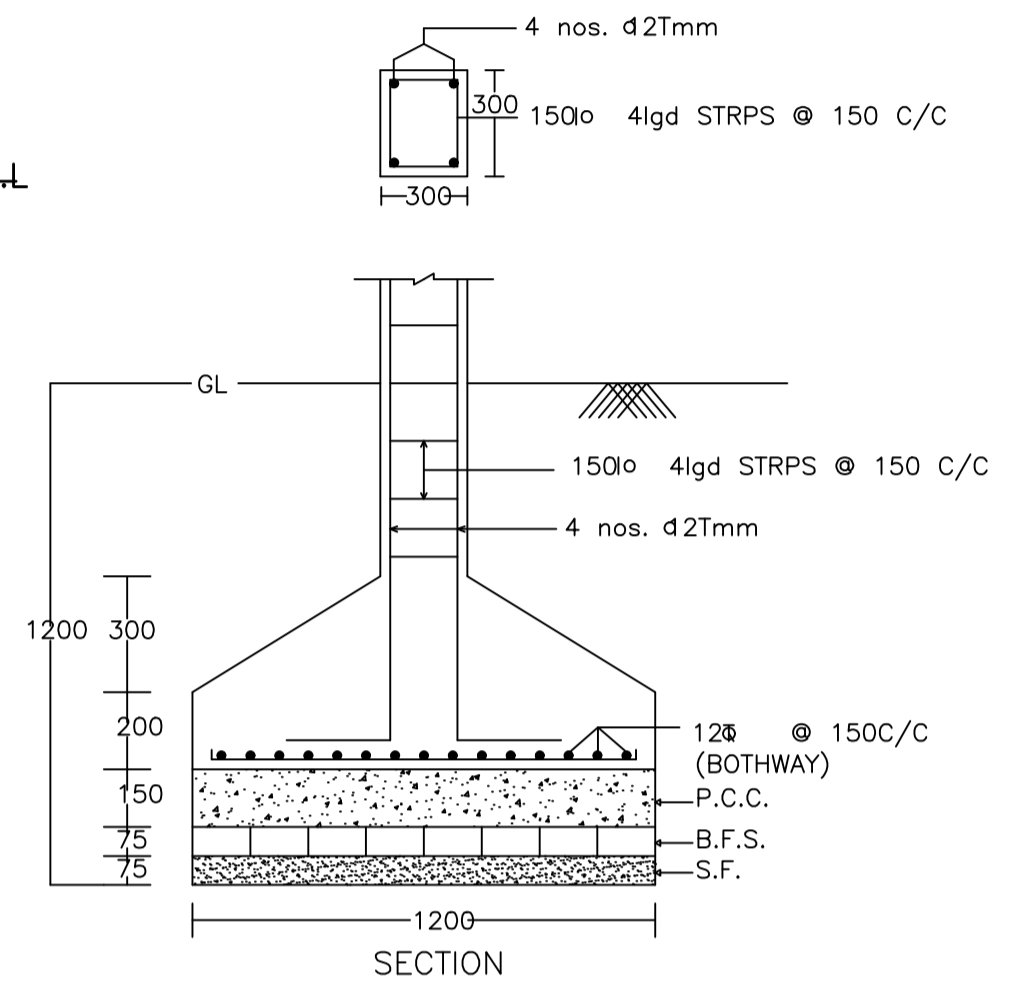

SECTION

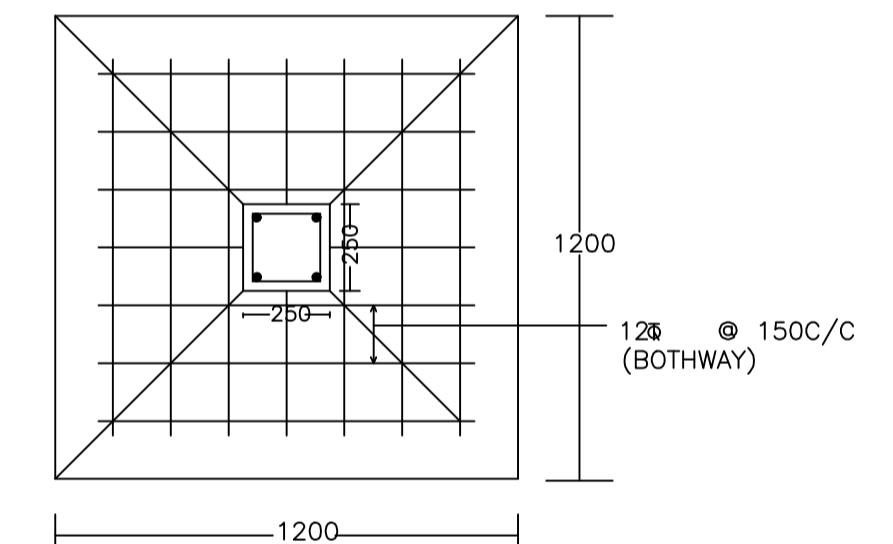

PLAN

DETAIL OF COLUMNS

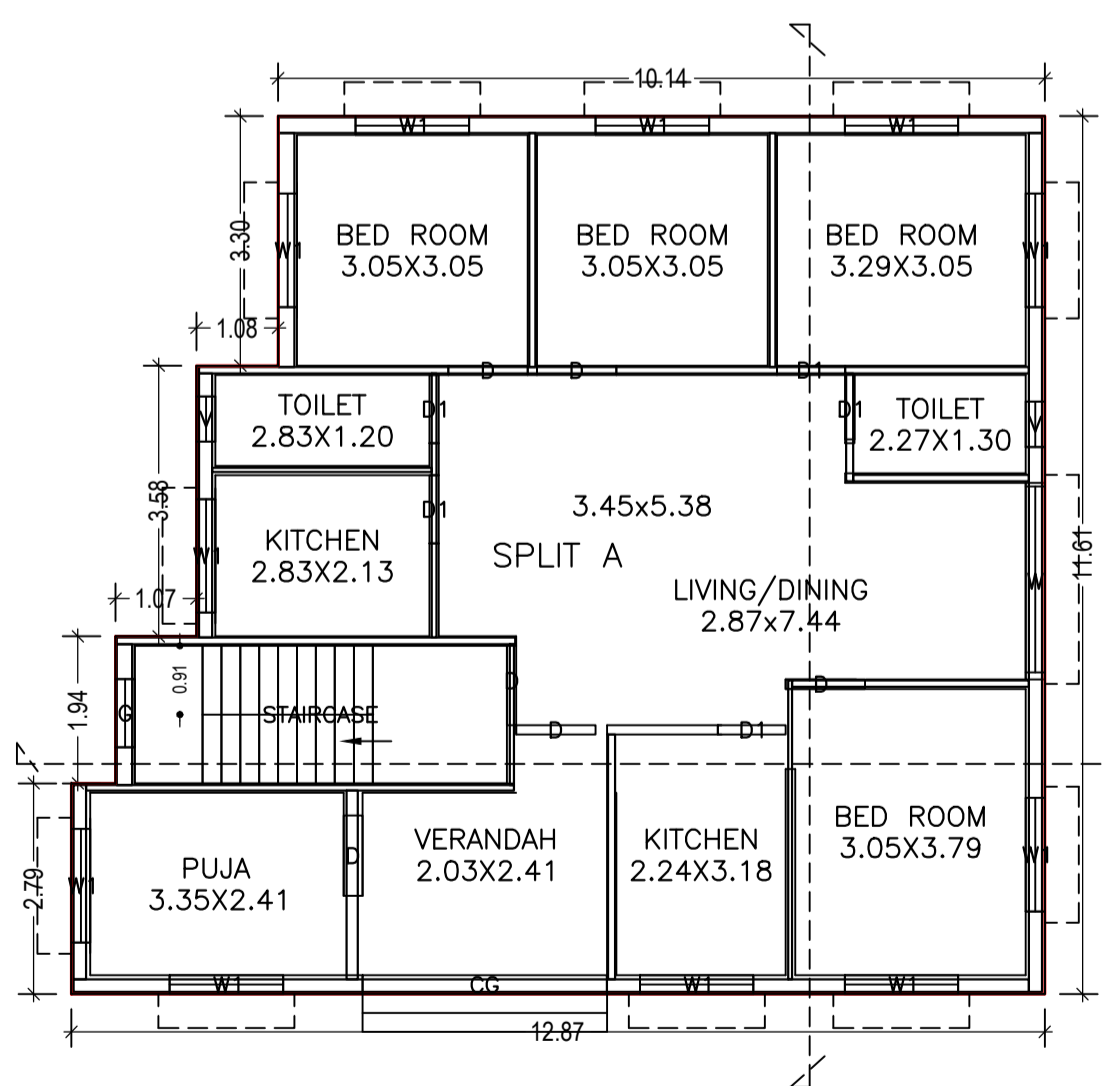

GROUND FLOOR PLAN
(Proposed)
(SCALE 1:100)

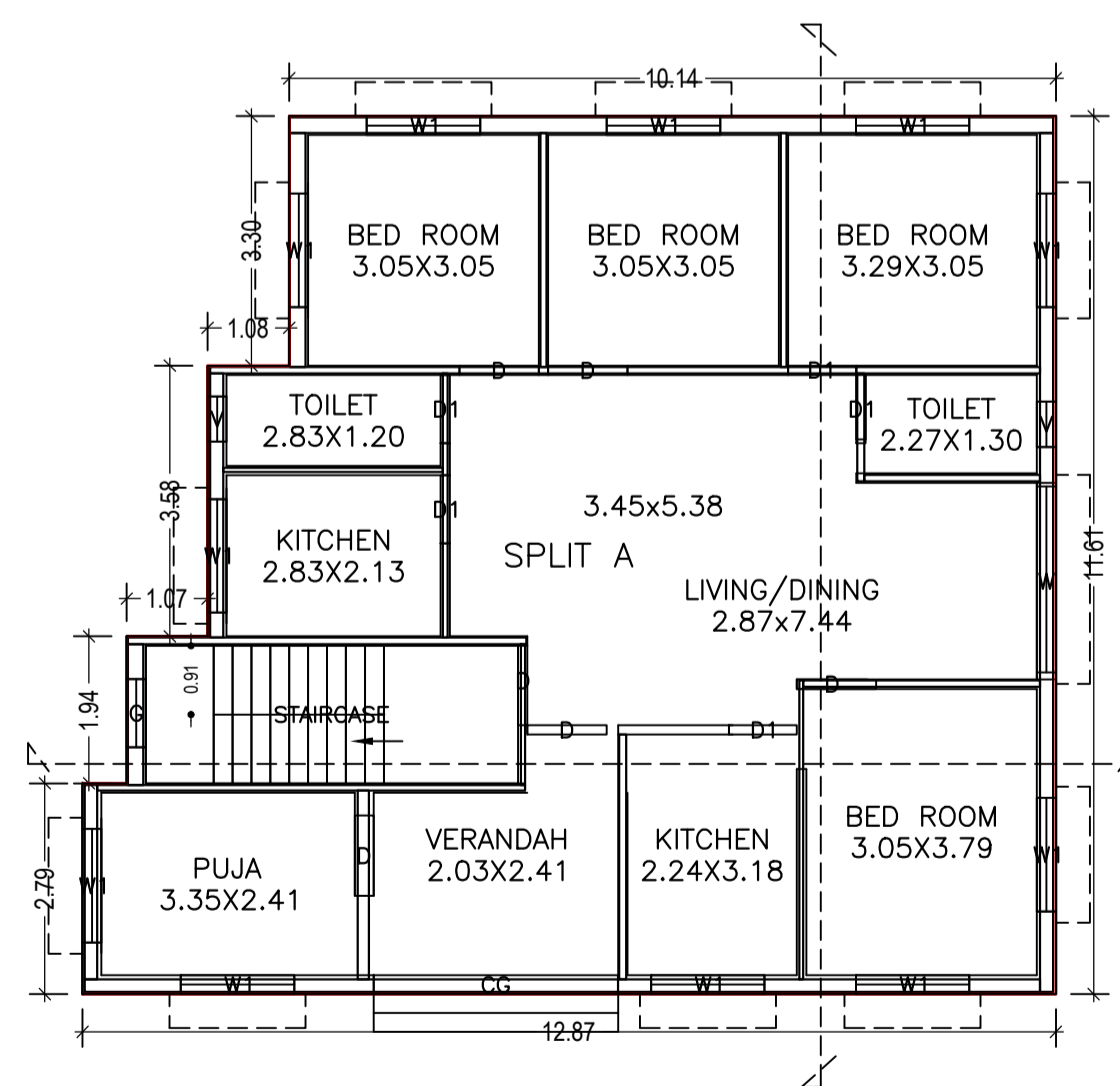

FIRST FLOOR PLAN
(Proposed)
(SCALE 1:100)

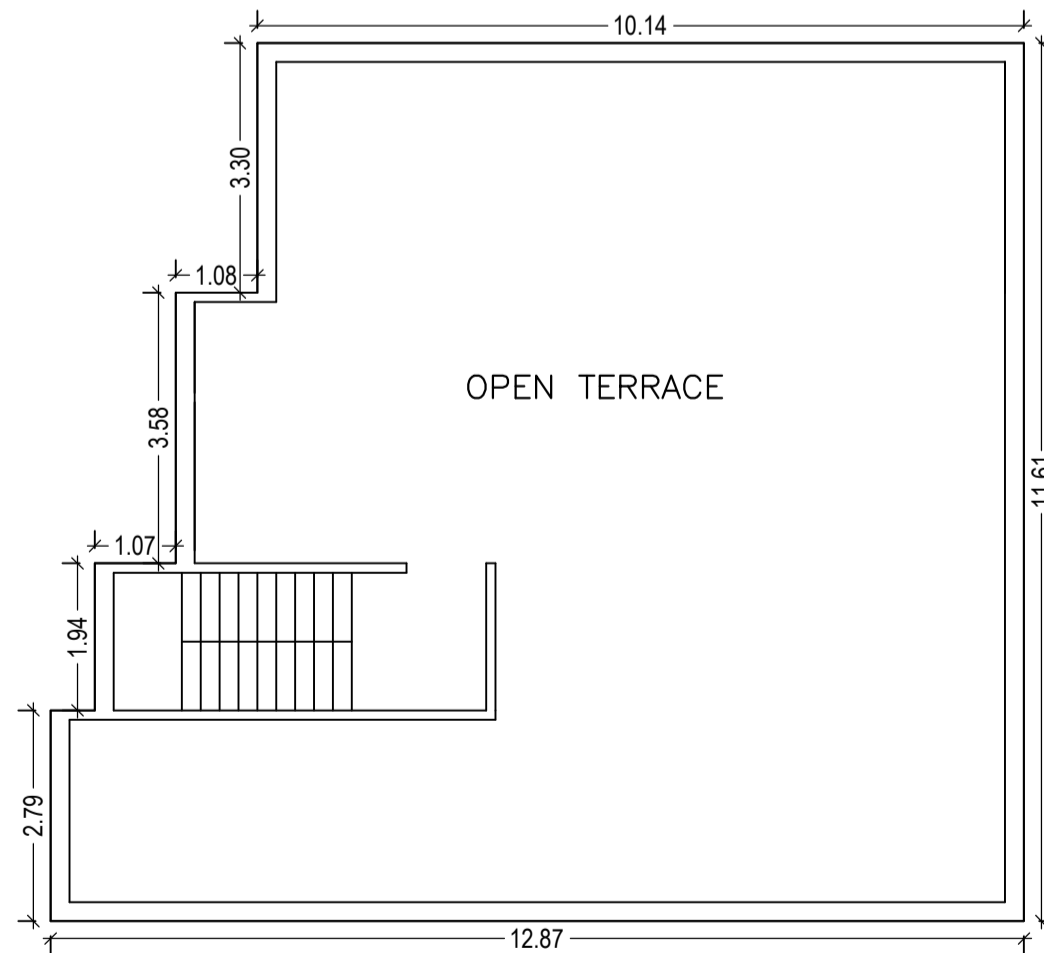

TERRACE FLOOR PLAN
(SCALE 1:100)

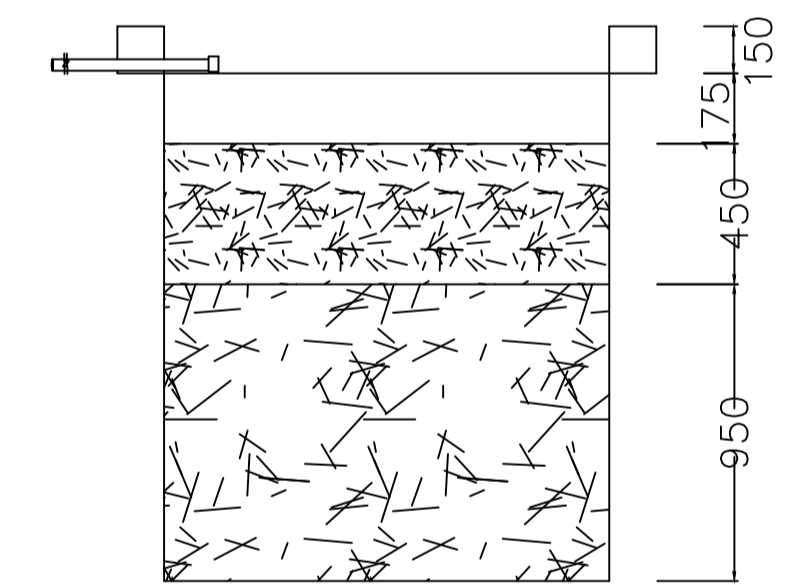

SECTION AT Y-Y

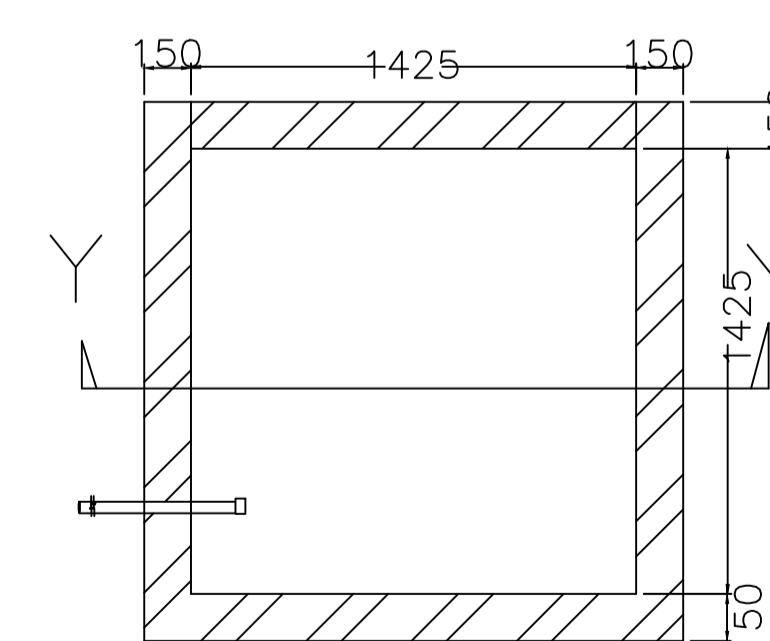

PLAN OF RECHARGE WELL

WATER HARVESTING

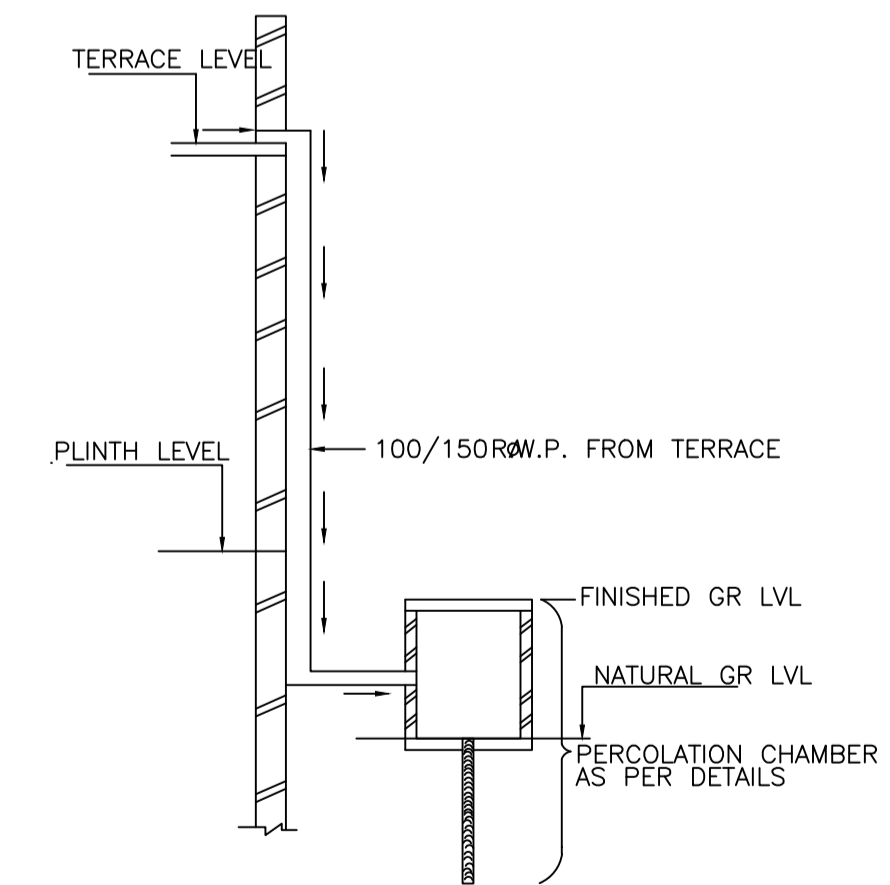

ROOF TOP RAIN WATER
COLLECTION SYSTEM

LTP NAME AND SIGNATURE	STRUCTURAL ENG'S NAME AND SIGNATURE	BUILDER NAME AND SIGNATURE
AMARENDRA KUMAR DMC/ENG/0009/2016		