

SITE PLAN

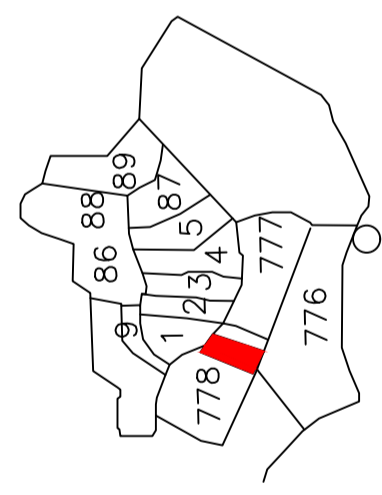

KEY PLAN

FAR & Tenement Details (Table 4c-1)

Building	No. of Same Bldg	Total Built Up Area (Sq.mt.)	Proposed FAR Area (Sq.mt.)	Total FAR Area (Sq.mt.)	Total Consumed Additional FAR Area (Sq.mt.)	Tnmt (No.)
A (RESI 1)	1	190.52	190.52	190.52	190.52	01
Grand Total:	1	190.52	190.52	190.52	190.52	01

SCHEDULE OF DOOR:

BUILDING NAME	NAME	LENGTH	HEIGHT	NOS
A (RESI 1)	D2	0.80	2.10	01
A (RESI 1)	D2	0.90	2.10	08
A (RESI 1)	D	1.04	2.10	02
A (RESI 1)	D1	1.05	2.10	07
A (RESI 1)	D	1.20	2.10	03

SCHEDULE OF WINDOW/VENTILATION:

BUILDING NAME	NAME	LENGTH	HEIGHT	NOS
A (RESI 1)	V	0.60	1.20	03
A (RESI 1)	W1	1.50	1.20	16

UnitBUA Table for Building :A (RESI 1)

FLOOR	Name	UnitBUA Type	UnitBUA Area	Carpet Area	No. of Rooms	No. of Tenement
GROUND FLOOR PLAN	SPLIT RESI 2	FLAT	156.88	156.09	11	1
FIRST FLOOR PLAN	SPLIT RESI 2		0.00	0.00	12	0
Total:			156.88	156.09	23	1

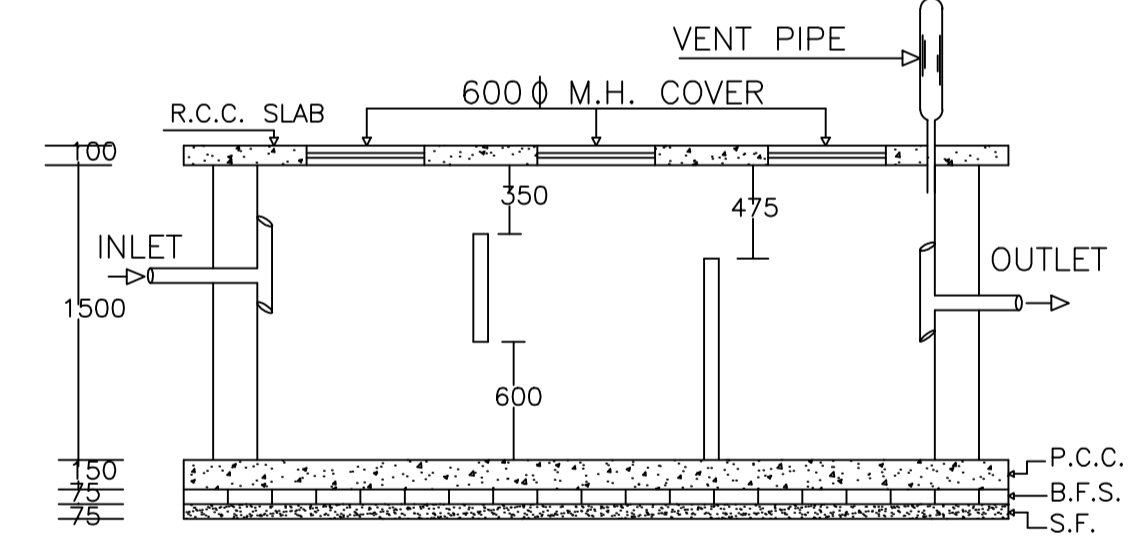

PLAN OF SEPTIC TANK

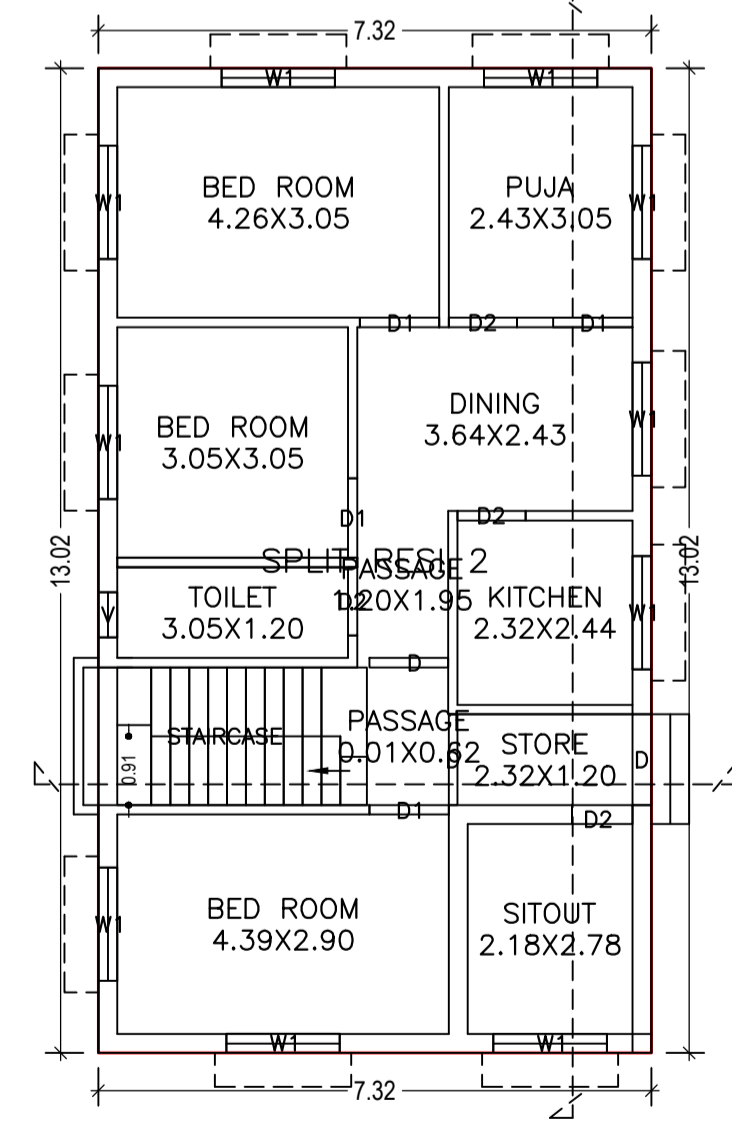

GROUND FLOOR PLAN (Proposed) (SCALE 1:100)

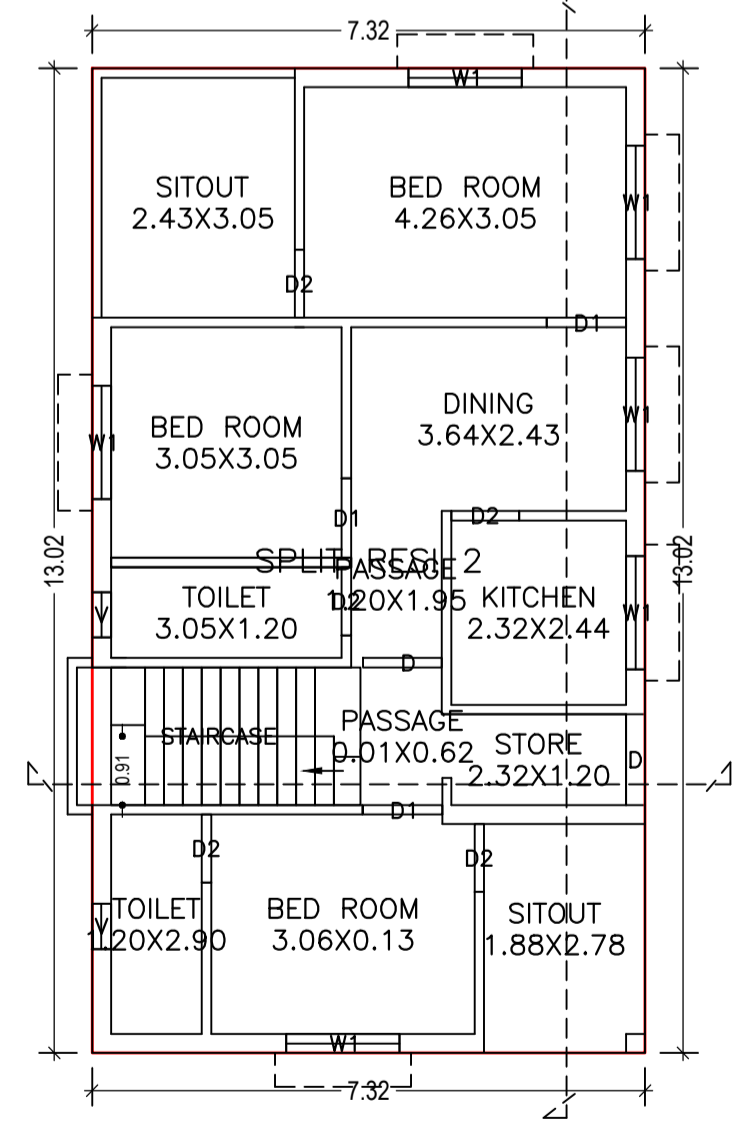

FIRST FLOOR PLAN (Proposed) (SCALE 1:100)

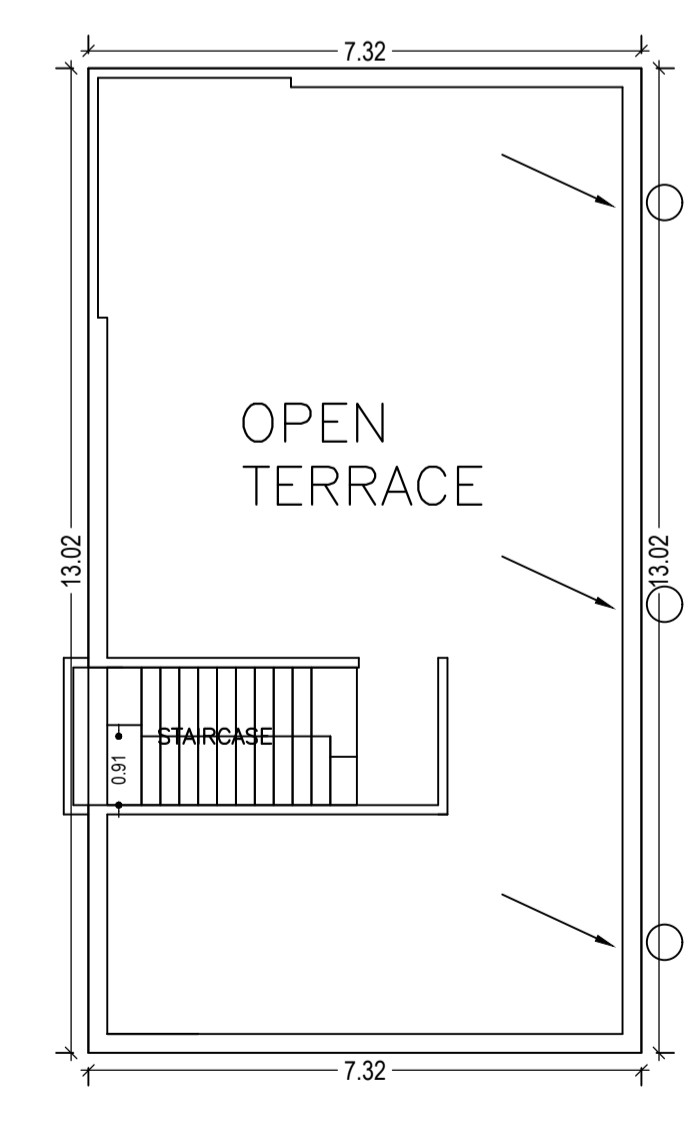

TERRACE FLOOR PLAN (SCALE 1:100)

Proposal Basic Information	
Proposal File No.	DMC/BP/0042/W23/2018
Owner Name	SMT CHANDRAWATI DEVI
Khata No	15
Plot No	778
Village Name	Kolakusma
Use	Residential
SubUse	Bungalow/ Dwelling / Non Apartment

AREA STATEMENT		VERSION NO.:	1.0.28
DHANBAD MUNICIPAL CORPORATION		VERSION DATE:	30/06/2018
<b>PROJECT DETAIL:</b>			
Region: JHARKHAND URBAN LOCAL BODIES	Plot Use:	Residential	
District: DHANBAD	Plot SubUse:	Bungalow/ Dwelling / Non Apartment	
Authority: DHANBAD MUNICIPAL CORPORATION	PlotNearbyReligiousStructure:	NA	
Inward No: DMC/BP/0042/W23/2018	Plot/SubPlot No:	778	
Application Type: General Proposal	North Plot No.:	plot no 778	
Project Type: Building Permission	South Plot No.:	plot no 778	
Nature of Development: New	East Plot No.:	plot no 781	
Location of Development Area: Old Area	West Road Width:	4.88	
<b>AREA DETAILS:</b>			
AREA OF PLOT (Minimum)	(A)	SQ.MT.	161.89
NET AREA OF PLOT(Gross Plot Area - Deduction from Gross Plot area)	(A-Deductions)		161.89
Deduction for Balance Plot Area(from Gross Plot Area)			
Common Plot			19.90
Total			19.90
BALANCE AREA OF PLOT(Net Plot Area - Recreational/Amenity space)	(A-Deductions)		141.99
PLOT AREA FOR COVERAGE(Net Plot Area)	(A-Deductions)		161.89
Plot Area for FAR (Net Plot Area + Road/Widening Area)	(A-Deductions)		161.89
<b>COVERAGE CHECK</b>			
Permissible Coverage area ( 70.00 % )			113.32
Proposed Coverage Area ( 58.84 % )			95.26
Total Prop. Coverage Area ( 58.84 % )			95.26
Balance coverage area ( 11.16 % )			18.06
<b>FAR CHECK</b>			
Perm. FAR Area ( 1.80 )			291.40
Total Perm. FAR area			291.40
Residential FAR			190.52
Proposed FAR Area			190.52
Total Proposed FAR Area			190.52
Consumed FAR (Factor)			1.18
Balance FAR Area			100.88
<b>BUILT UP AREA CHECK</b>			
Total Proposed BuiltUp Area			190.52
ARCHITECT (Regd)			TULSI CHAUDHARI
ENGINEER (Regd)			
SUPERVISOR (Regd)			
OWNER (Regd)			SMT CHANDRAWATI DEVI
DEVELOPMENT AUTHORITY			LOCAL BODY

COLOR INDEX	
PLOT BOUNDARY	Black
ABUTTING ROAD	Green
PROPOSED CONSTRUCTION	Red
COMMON PLOT	Yellow
ROAD WIDENING AREA	Blue
EXISTING (To be retained)	Orange
EXISTING (To be demolished)	Grey

Buildingwise Floor FAR Details

Floor Name	Building Name A (RESI 1)		Total	
	Proposed Built Up Area (Sq.mt.)	Proposed FAR Area (Sq.mt.)	Total Proposed Built Up Area (Sq.mt.)	Total FAR Area (Sq.mt.)
Ground Floor	95.26	95.26	95.26	95.26
First Floor	95.26	95.26	95.26	95.26
Terrace Floor	0.00	0.00	0.00	0.00
Total :	190.52	190.52	190.52	190.52

Building :A (RESI 1)

Floor Name	Total Built Up Area (Sq.mt.)	Proposed FAR Area (Sq.mt.)	Total FAR Area (Sq.mt.)	Total Consumed Additional FAR Area (Sq.mt.)	Tnmt (No.)
Ground Floor	95.26	95.26	95.26	95.26	01
First Floor	95.26	95.26	95.26	95.26	00
Terrace Floor	0.00	0.00	0.00	0.00	00
Total :	190.52	190.52	190.52	190.52	01
Total Number of Same Buildings :	1				
Total :	190.52	190.52	190.52	190.52	01

Building USE/SUBUSE Details

Building Name	Building Use	Building SubUse	Building Structure
A (RESI 1)	Residential	Bungalow/ Dwelling / Non Apartment	Non-Highrise

LTP NAME AND SIGNATURE	STRUCTURAL ENG'S NAME AND SIGNATURE	BUILDER NAME AND SIGNATURE
TULSI CHAUDHARI DMC/STU/0005/2017		

Proposal Basic Information	
Proposal File No.	DMC/BP/0042/W23/2018
Owner Name	SMT CHANDRAWATI DEVI
Khata No	15
Plot No	778
Village Name	Kolakusma
Use	Residential
SubUse	Bungalow/ Dwelling / Non Apartment

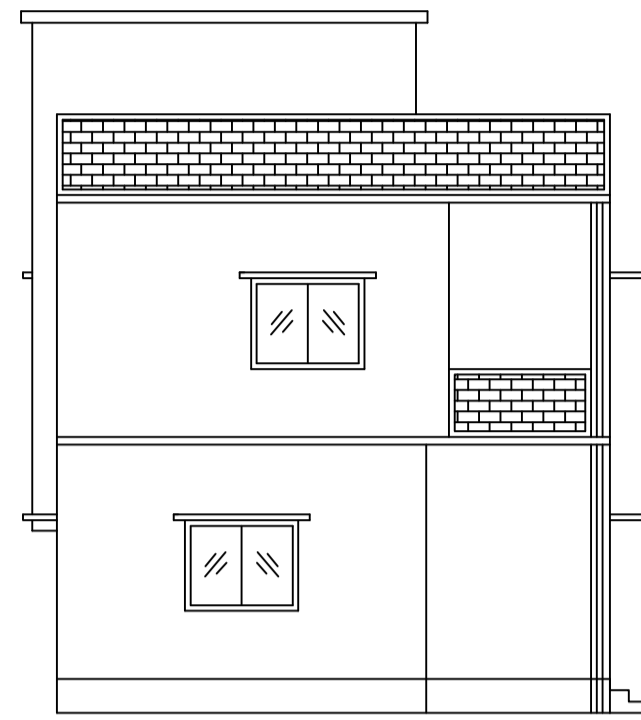

FRONT ELEVATION



RIGHT SIDE ELEVATION

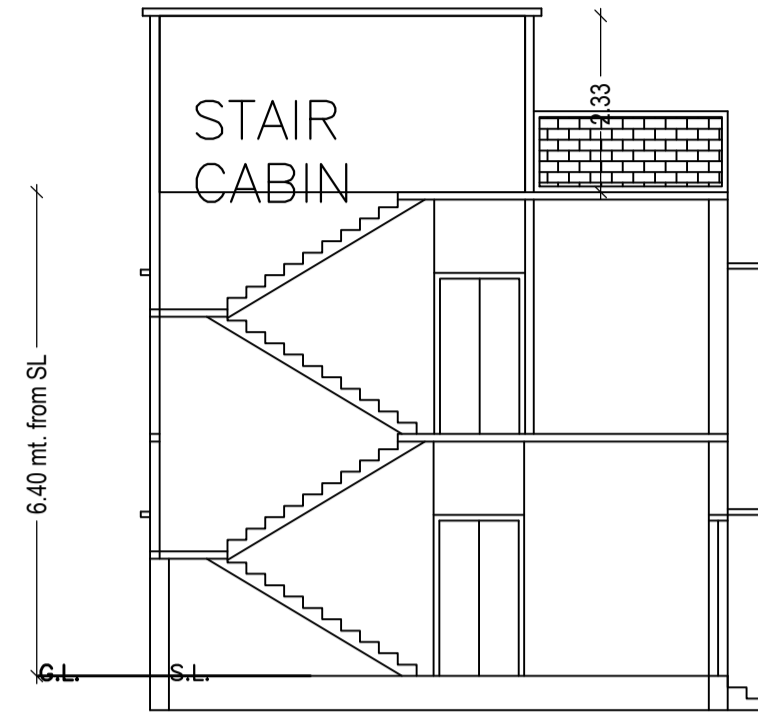

SECTION ON X-X

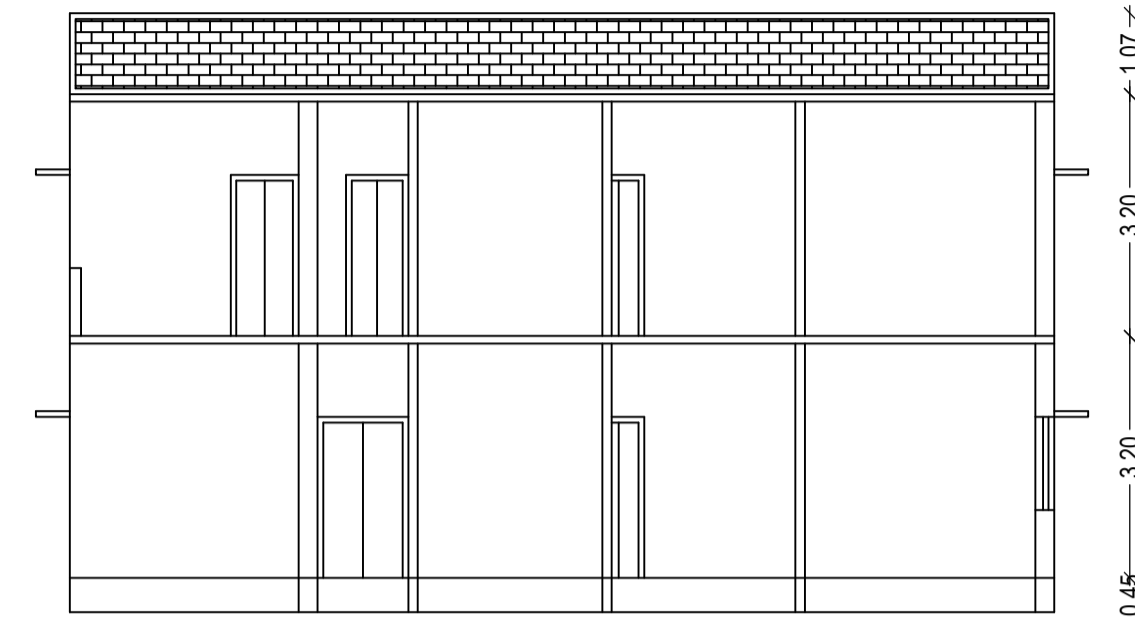

SECTION ON Y-Y

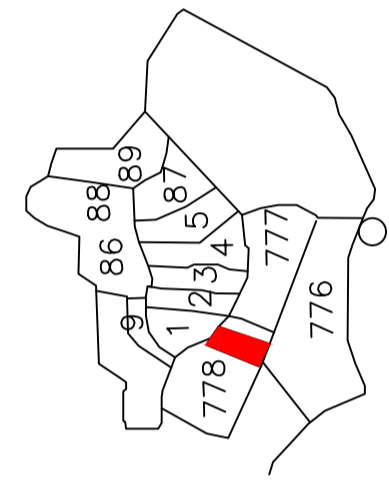

KEY PLAN

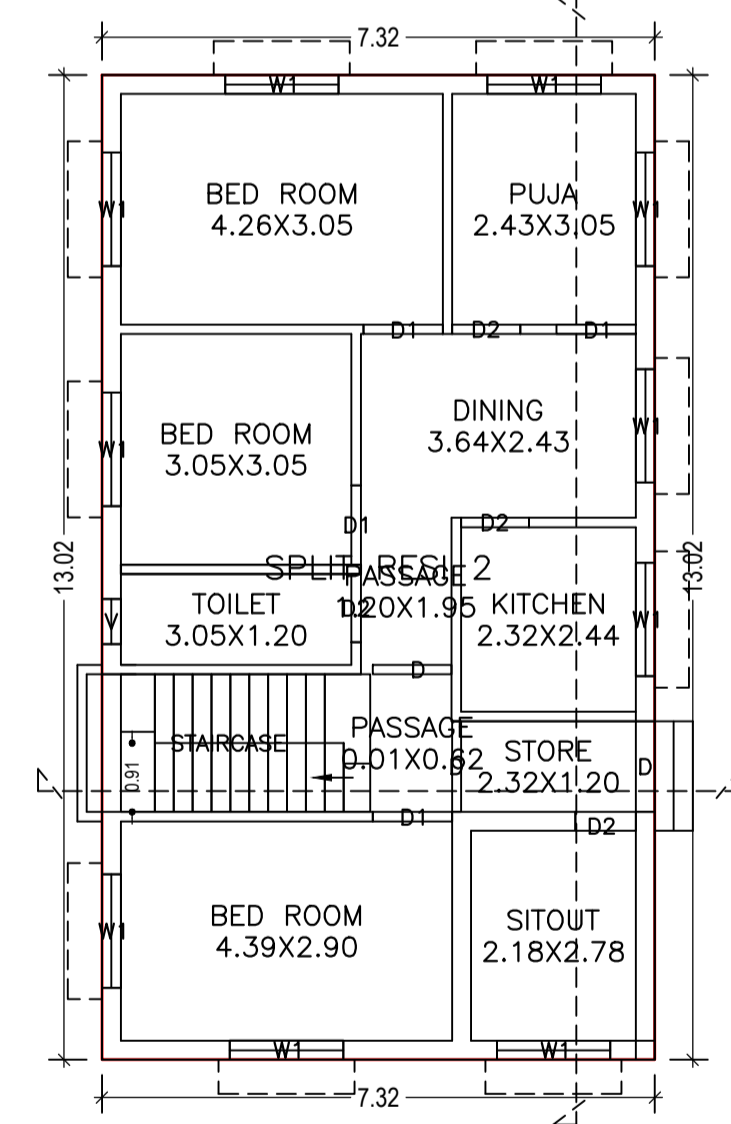

GROUND FLOOR PLAN  
(Proposed)  
(SCALE 1:100)

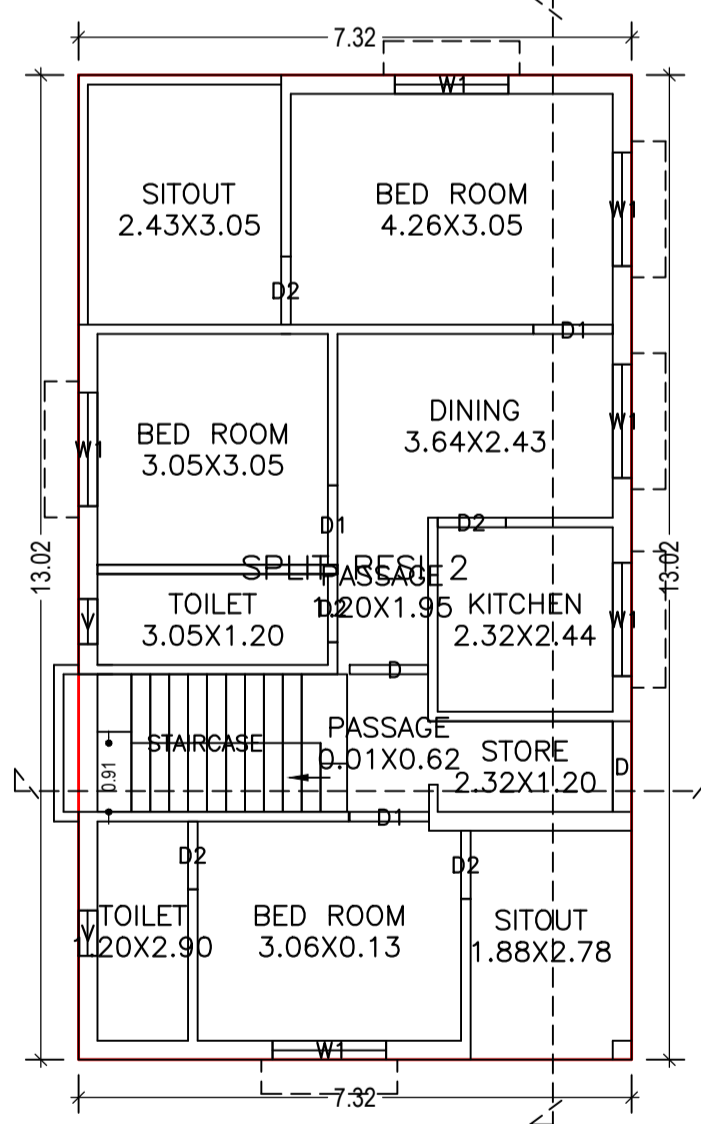

FIRST FLOOR PLAN  
(Proposed)  
(SCALE 1:100)

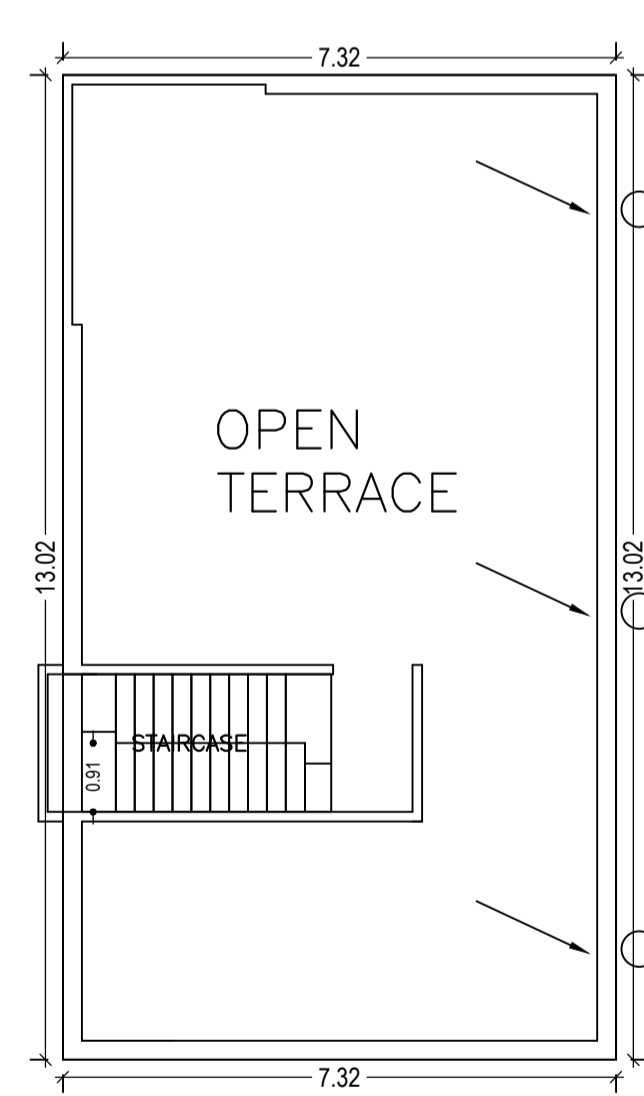

TERRACE FLOOR PLAN  
(SCALE 1:100)

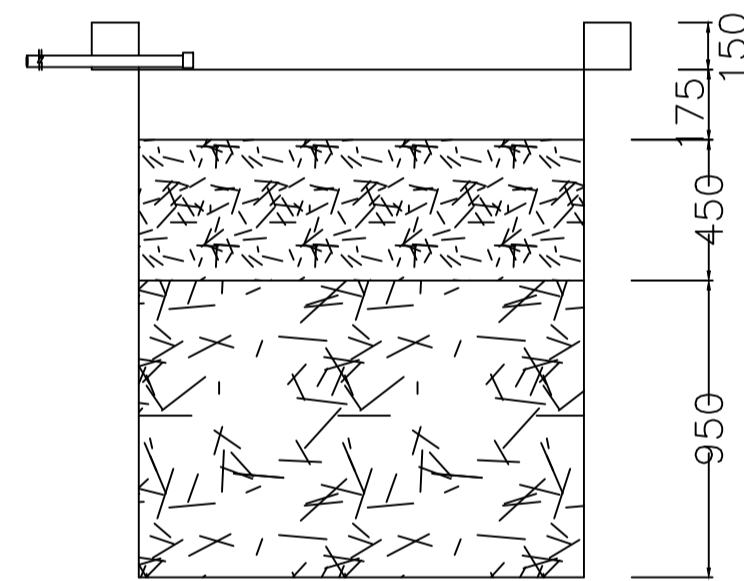

SECTION AT Y-Y

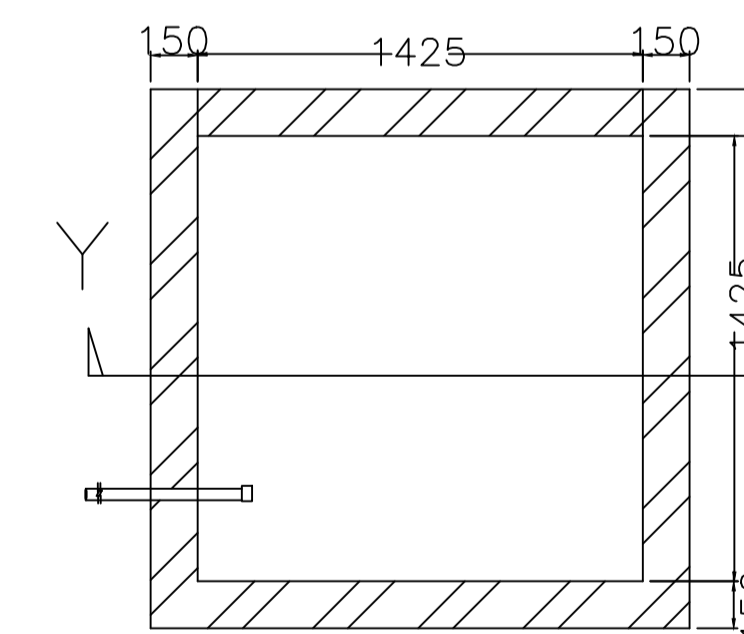

PLAN OF RECHARGE WELL

WATER HARVESTING

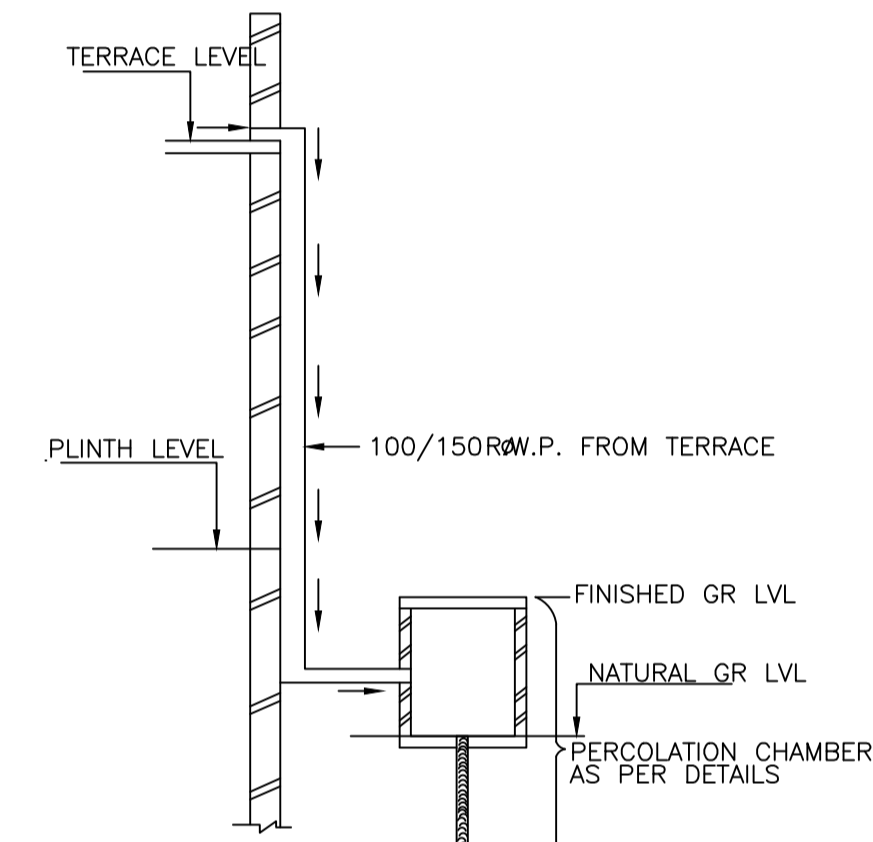

ROOF TOP RAIN WATER  
COLLECTION SYSTEM

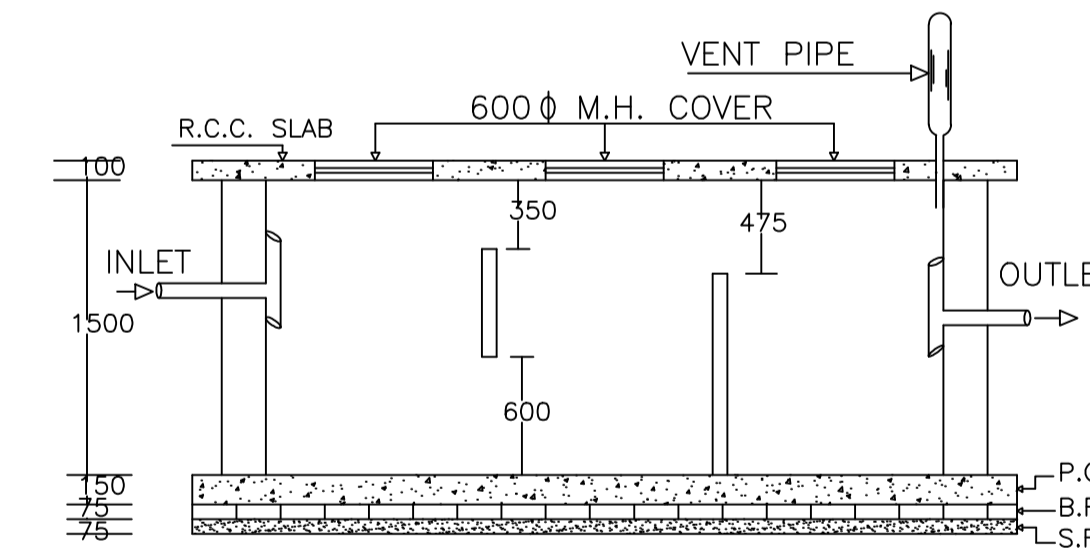

PLAN OF SEPTIC TANK

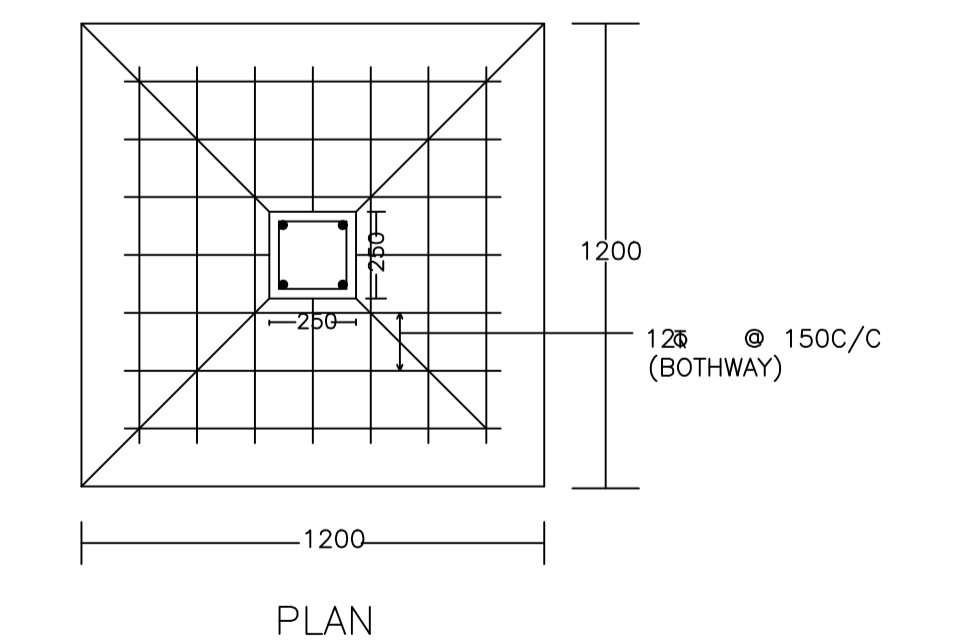
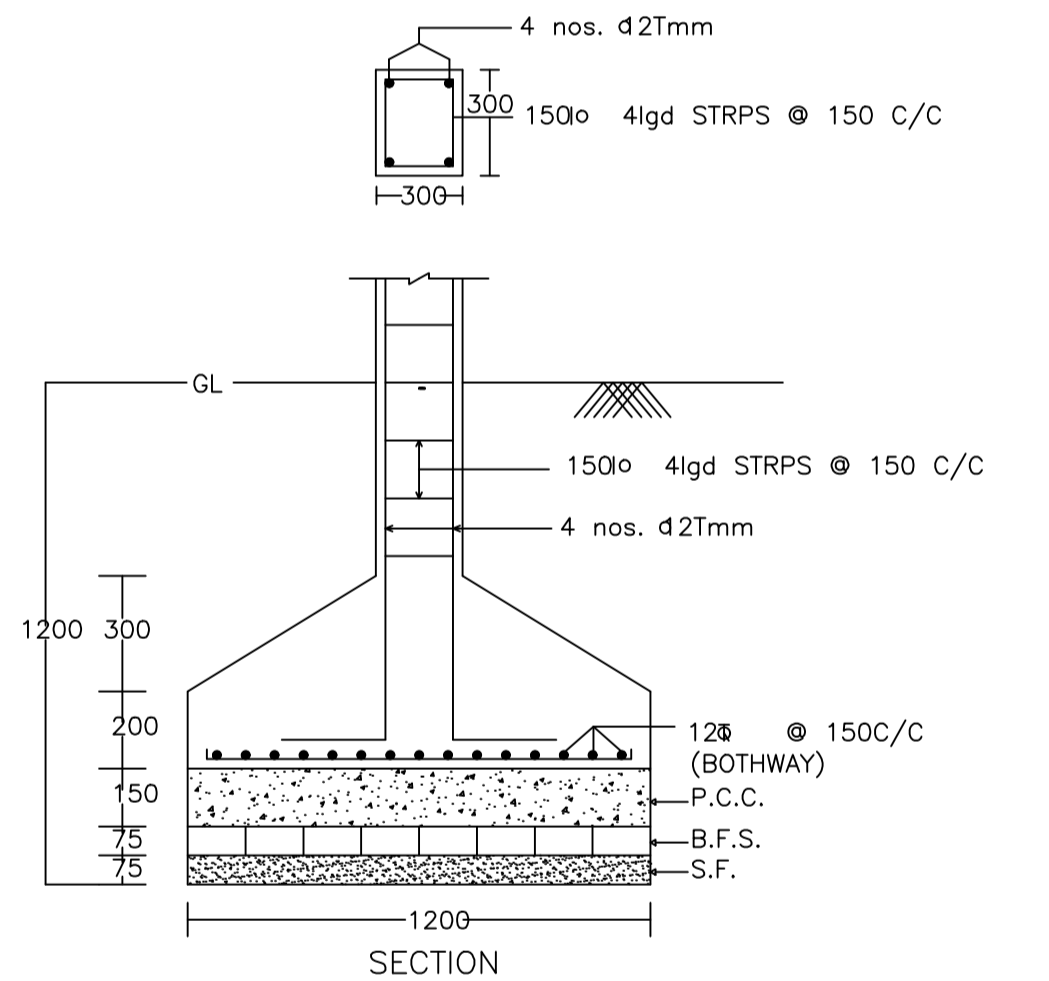

DETAIL OF COLUMNS

LTP NAME AND SIGNATURE	STRUCTURAL ENG'S NAME AND SIGNATURE	BUILDER NAME AND SIGNATURE
TULSI CHAUDHARI DMC/STU/0005/2017		