

SECTION ON X-X

SECTION ON Y-Y

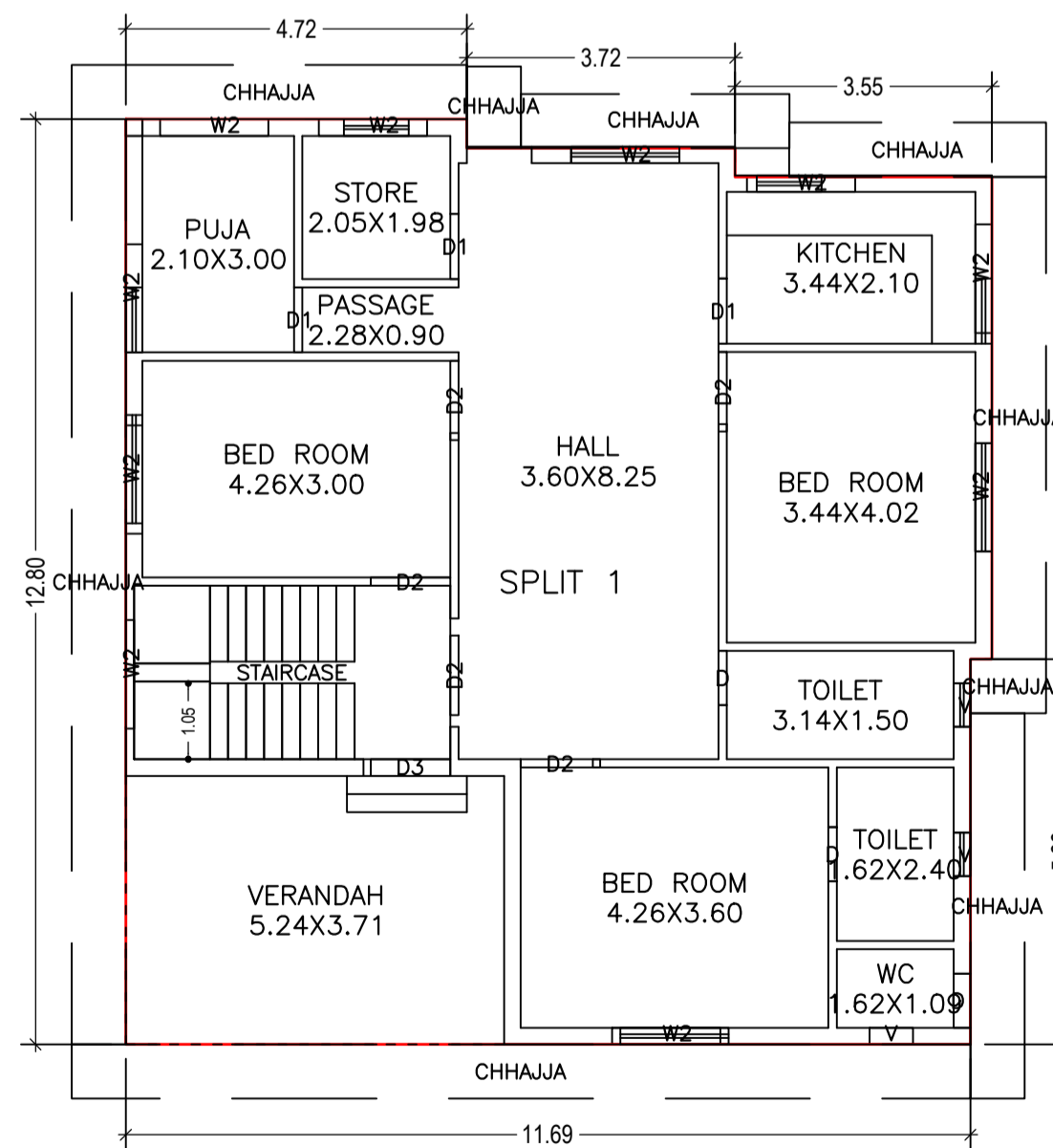

GROUND FLOOR PLAN (Proposed) (SCALE 1:100)

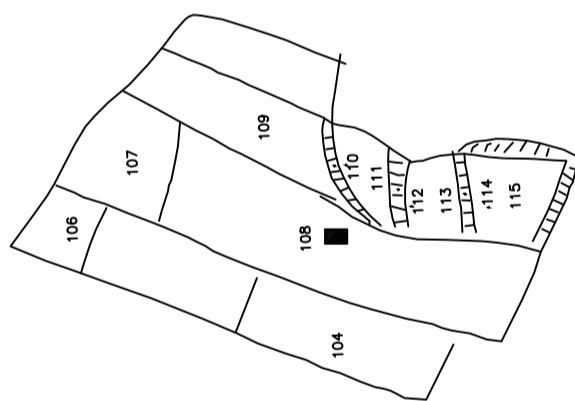
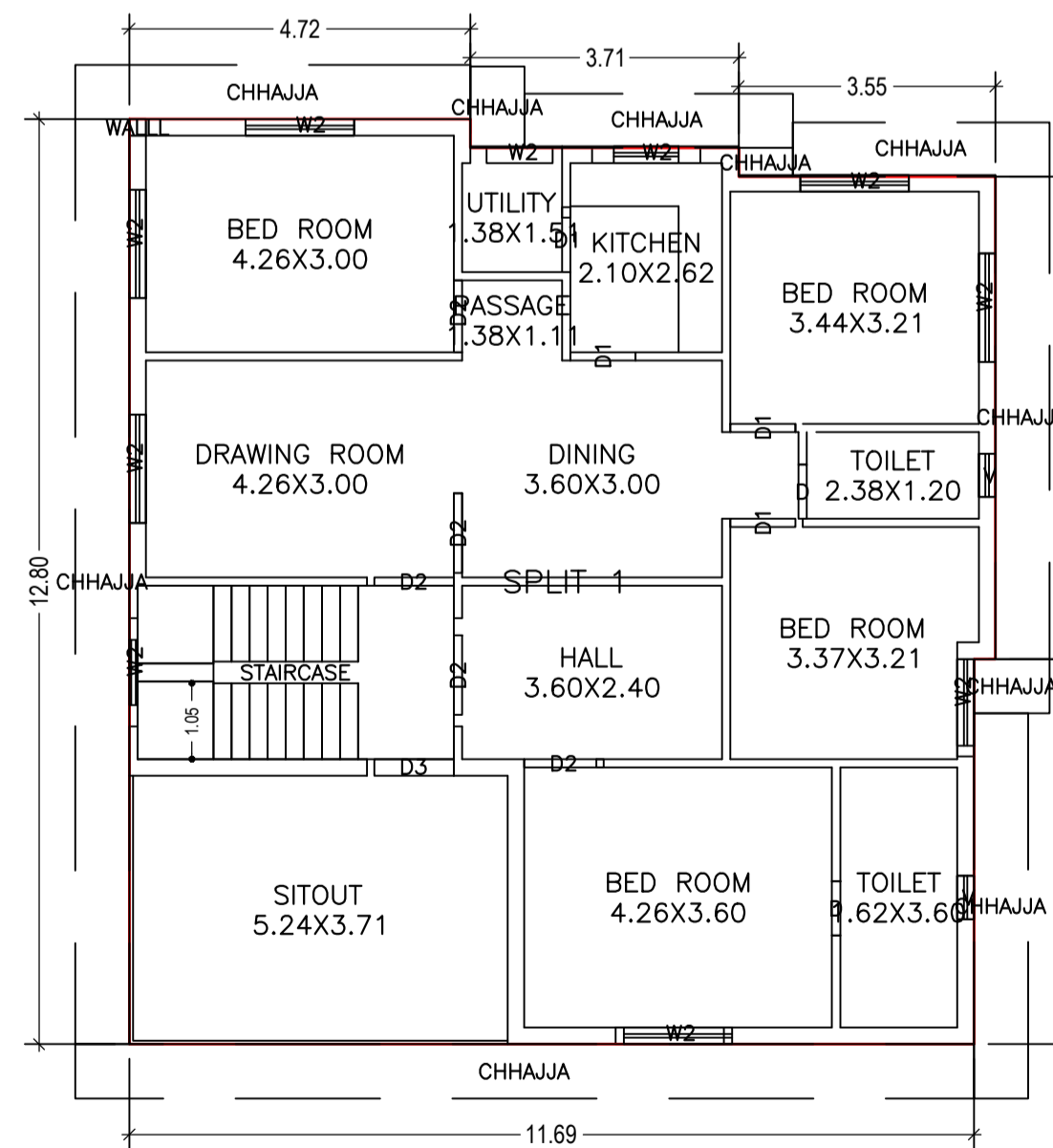

FIRST FLOOR PLAN (Proposed) (SCALE 1:100)

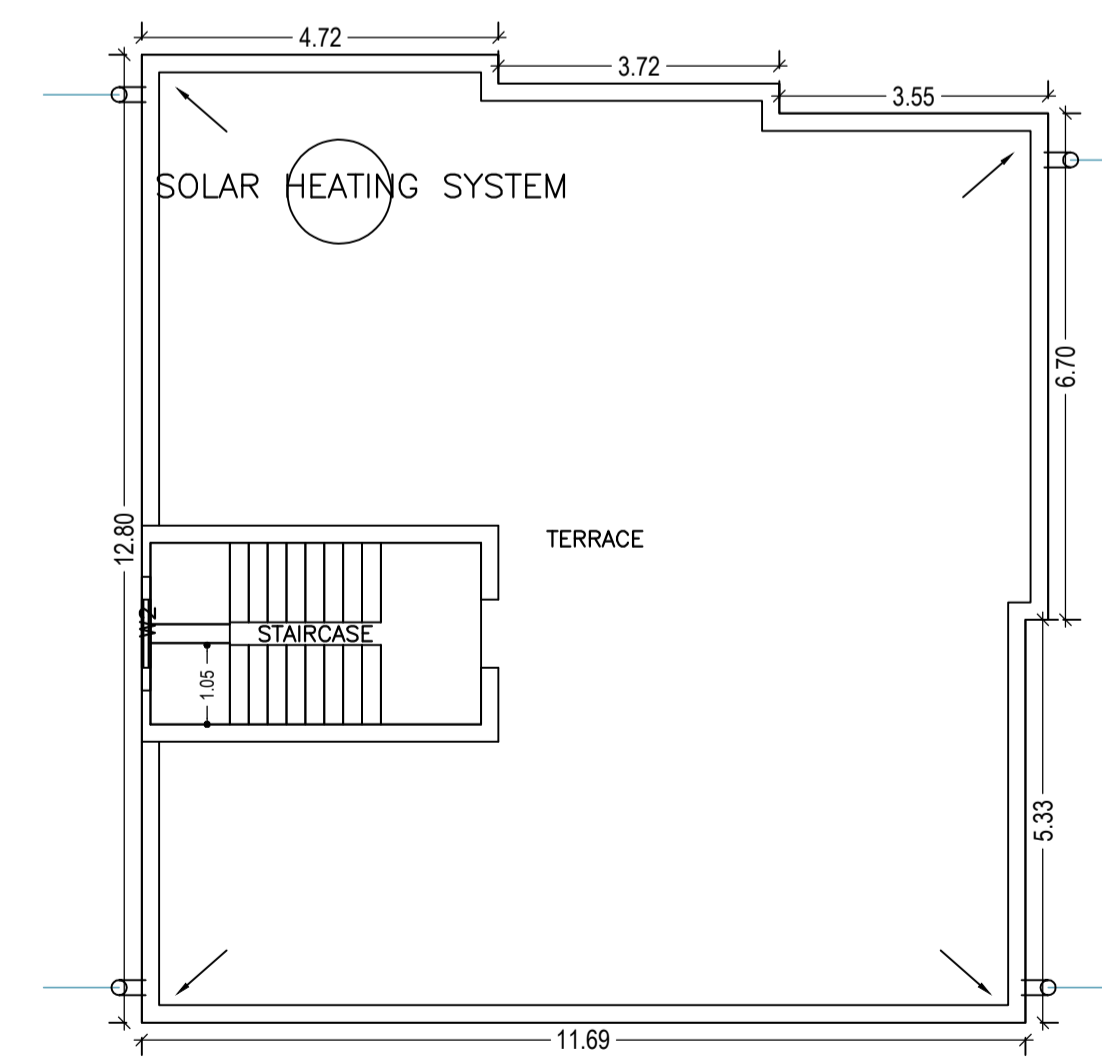

TERRACE FLOOR PLAN (SCALE 1:100)

Proposal Basic Information	
Proposal File No.	DMC/BP/0235/W29/2019
Owner Name	SMT. TULU DEVI.
Khata No	105
Plot No	108
Village Name	Bhuda
Use	Residential
SubUse	Bungalow/ Dwelling / Non Apartment

AREA STATEMENT		VERSION NO. : 1.041
DHANBAD MUNICIPAL CORPORATION		VERSION DATE: 29/04/2019
PROJECT DETAIL:		
Region: JHARKHAND URBAN LOCAL BODIES	Plot Use: Residential	
District: DHANBAD	Plot SubUse: Bungalow/ Dwelling / Non Apartment	
Authority: DHANBAD MUNICIPAL CORPORATION	Plot/Nearby/Religious Structure: NA	
Inward No: DMC/BP/0235/W29/2019	Plot/SubPlot No: 108	
Application Type: General Proposal	North: Plot No. - RADHA DEVI	
Project Type: Building Permission	South: Plot No. - TANPTI DUTTA	
Nature of Development: New	East: Survey No. - NALI	
Location of Development Area: Old Area	West: Road Width - 4.50	
AREA DETAILS:		
AREA OF PLOT (Minimum)	(A)	SQ.MT. 230.59
NET AREA OF PLOT (Gross Plot Area - Deduction from Gross Plot area)	(A-Deductions)	230.59
Deduction for Balance Plot Area (from Gross Plot Area)		
Common Plot		32.70
Total		32.70
BALANCE AREA OF PLOT (Net Plot Area - Recreational/Amenity space)	(A-Deductions)	197.89
PLOT AREA FOR COVERAGE (Net Plot Area)	(A-Deductions)	230.59
Plot Area for FAR (Net Plot Area + Road Widening Area)	(A-Deductions)	230.59
COVERAGE CHECK		
Permissible Coverage area ( 70.00 % )		161.41
Proposed Coverage Area ( 64.00 % )		147.57
Total Prop. Coverage Area ( 64 % )		147.57
Balance coverage area ( 6.00 % )		13.84
FAR CHECK		
Perm. FAR Area ( 1.50 )		345.89
Total Perm. FAR area		345.89
Residential FAR		295.14
Proposed FAR Area		295.14
Total Proposed FAR Area		295.14
Consumed FAR (Factor)		1.28
Balance FAR Area		50.75
BUILT UP AREA CHECK		
Total Proposed BuiltUp Area		295.14
ARCHITECT (Regd)		PARTHA - PAL
ENGINEER (Regd)		
SUPERVISOR (Regd)		
OWNER (Regd)		SMT. TULU DEVI.
DEVELOPMENT AUTHORITY		LOCAL BODY

COLOR INDEX	
PLOT BOUNDARY	Black
ABUTTING ROAD	Green
PROPOSED CONSTRUCTION	Red
COMMON PLOT	Yellow
ROAD WIDENING AREA	Blue
EXISTING (To be retained)	Light Blue
EXISTING (To be demolished)	Light Yellow

Floor Name	Building Name A (B)		Total	
	Proposed Built Up Area (Sq.mt.)	Proposed FAR Area (Sq.mt.)	Total Proposed Built Up Area (Sq.mt.)	Total FAR Area (Sq.mt.)
Ground Floor	147.57	147.57	147.57	147.57
First Floor	147.57	147.57	147.57	147.57
Terrace Floor	0.00	0.00	0.00	0.00
Total :	295.14	295.14	295.14	295.14

Building Name	Building Use	Building SubUse	Building Structure
A (B)	Residential	Bungalow/ Dwelling / Non Apartment	Non-Highrise

FAR & Tenement Details (Table 4c-1)						
Building	No. of Same Bldg	Total Built Up Area (Sq.mt.)	Proposed FAR Area (Sq.mt.)	Total FAR Area (Sq.mt.)	Total Consumed Additional FAR Area (Sq.mt.)	Tnmt (No.)
A (B)	1	295.14	295.14	295.14	295.14	01
Grand Total :	1	295.14	295.14	295.14	295.14	01

UnitBUA Table for Building :A (B)						
FLOOR	Name	UnitBUA Type	UnitBUA Area	Carpet Area	No. of Rooms	No. of Tenement
GROUND FLOOR PLAN	SPLIT 1	FLAT	295.14	295.03	12	1
	SPLIT 1	FLAT	0.00	0.00	13	0
FIRST FLOOR PLAN						
Total:			295.14	295.03	25	1

SCHEDULE OF DOOR:				
BUILDING NAME	NAME	LENGTH	HEIGHT	NOS
A (B)	D	0.75	2.10	05
A (B)	D1	0.90	2.10	07
A (B)	D2	1.00	2.10	01
A (B)	D2	1.10	2.10	09
A (B)	D3	1.10	2.10	02

SCHEDULE OF WINDOW/VENTILATION:				
BUILDING NAME	NAME	LENGTH	HEIGHT	NOS
A (B)	V	0.60	0.60	05
A (B)	W2	0.91	1.20	01
A (B)	W2	1.35	1.20	01
A (B)	W2	1.50	1.20	19

Building :A (B)					
Floor Name	Total Built Up Area (Sq.mt.)	Proposed FAR Area (Sq.mt.)	Total FAR Area (Sq.mt.)	Total Consumed Additional FAR Area (Sq.mt.)	Tnmt (No.)
Ground Floor	147.57	147.57	147.57	147.57	01
First Floor	147.57	147.57	147.57	147.57	00
Terrace Floor	0.00	0.00	0.00	0.00	00
Total :	295.14	295.14	295.14	295.14	01
Total Number of Same Buildings	1				
Total :	295.14	295.14	295.14	295.14	01

LTP NAME AND SIGNATURE	STRUCTURAL ENG'S NAME AND SIGNATURE	BUILDER NAME AND SIGNATURE	DIGITAL SIGNATURE
PARTHA - PAL DMC/ENG/0021/2016			

Proposal Basic Information	
Proposal File No.	DMC/BP/0235/W29/2019
Owner Name	SMT. TULU DEVI.
Khata No	105
Plot No	108
Village Name	Bhuda
Use	Residential
SubUse	Bungalow/ Dwelling / Non Apartment

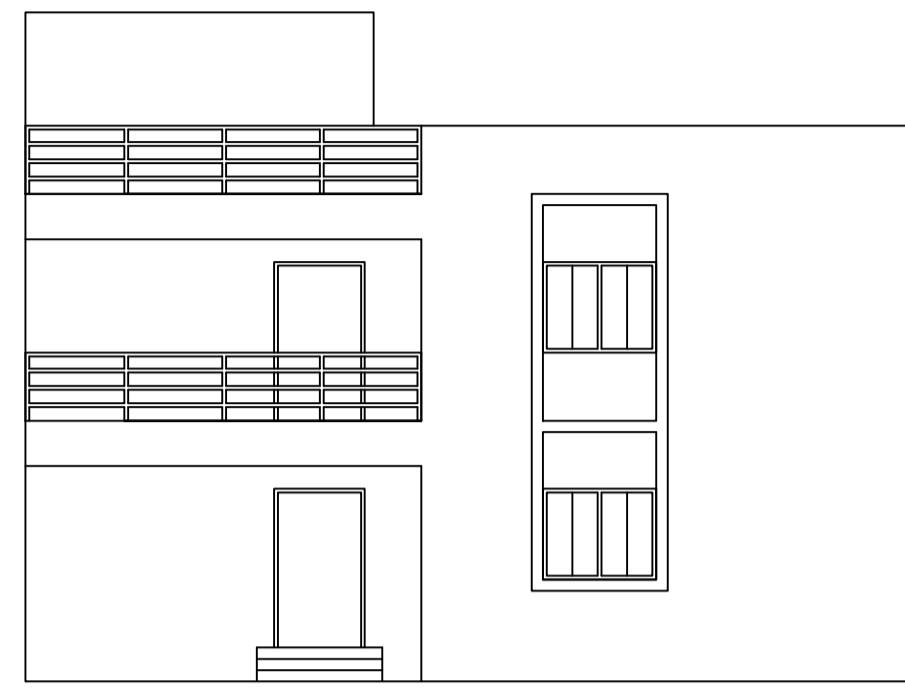

FRONT ELEVATION

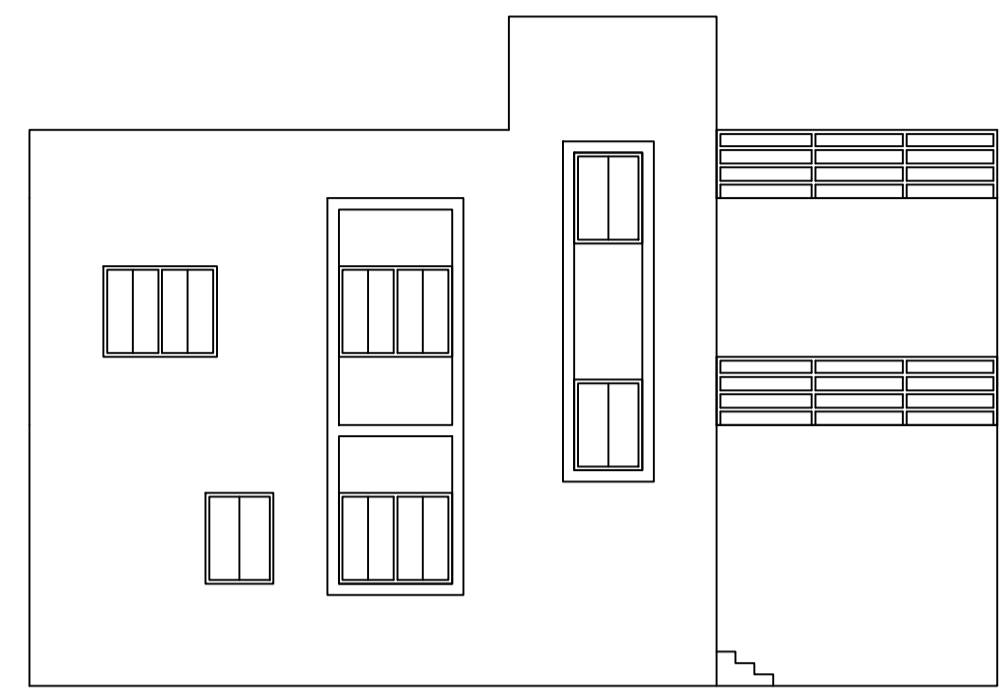

LEFT SIDE ELEVATION

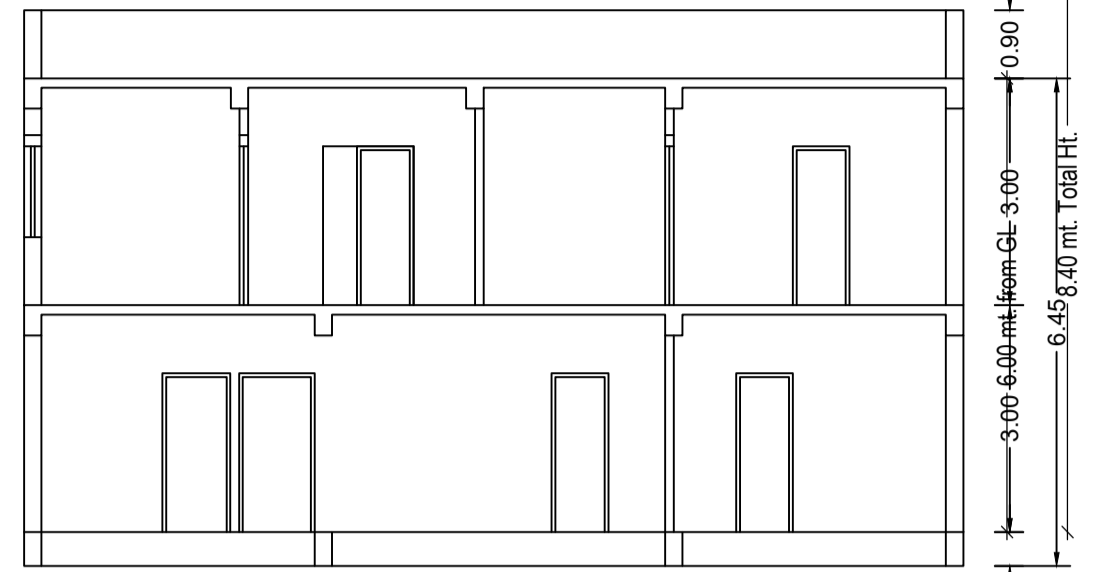

SECTION ON X-X

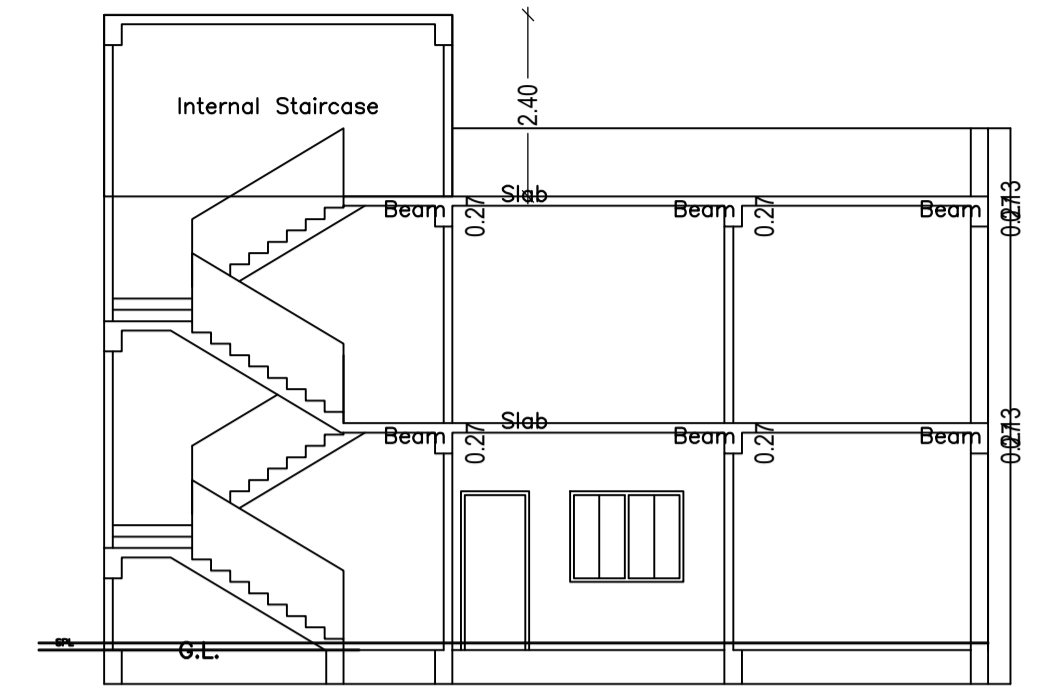

SECTION ON Y-Y

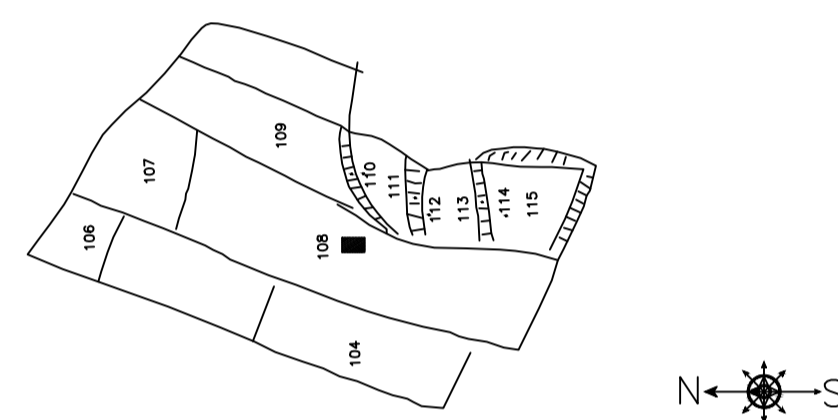

KEY PLAN  
SCALE:- 1"=3.30'

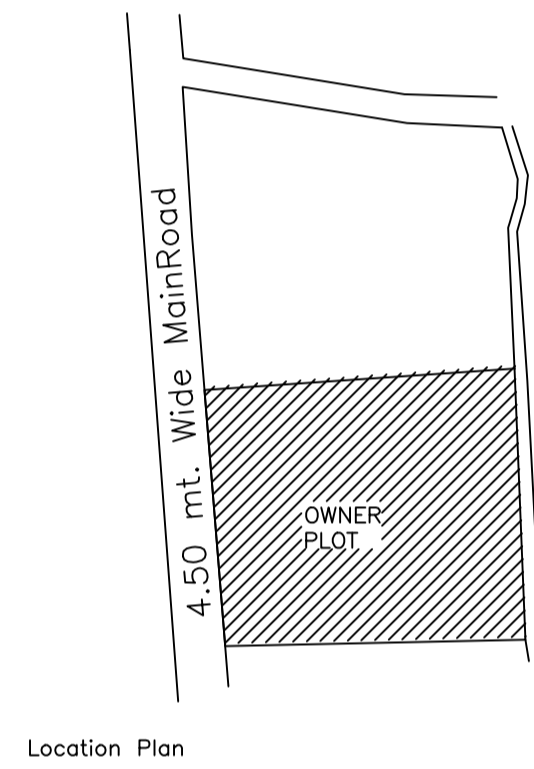

Location Plan

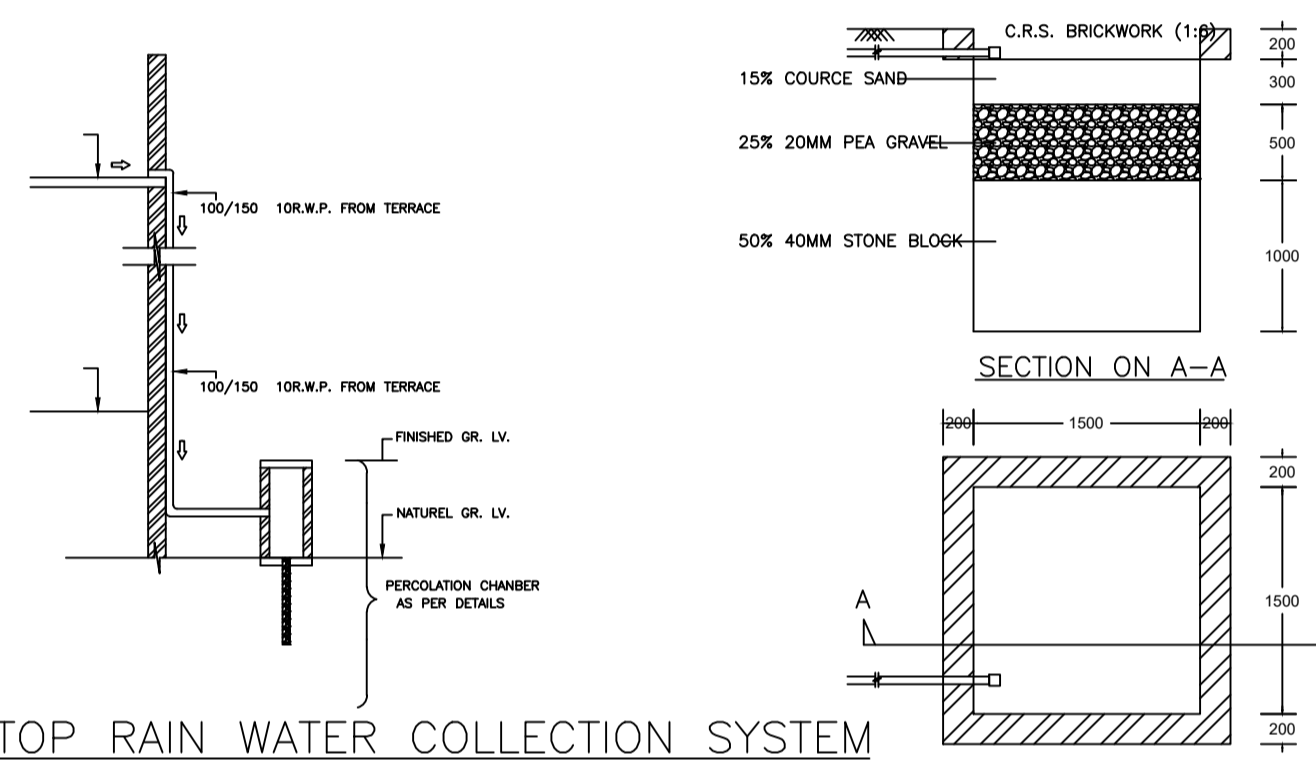

ROOF TOP RAIN WATER COLLECTION SYSTEM

PLAN OF RECHARGE WELL  
(WATER HARVESTING)

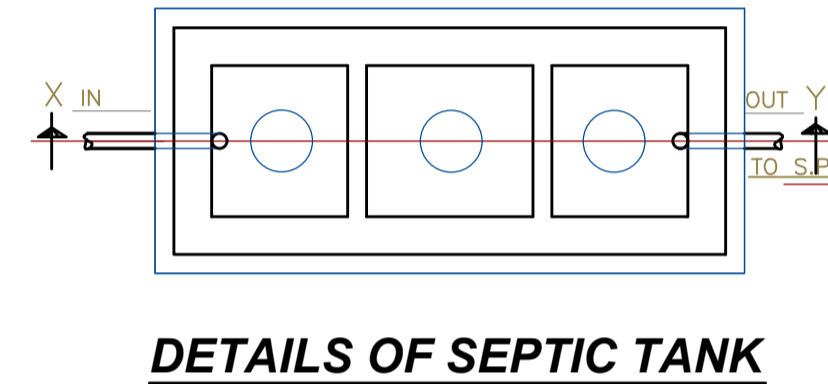

DETAILS OF SEPTIC TANK

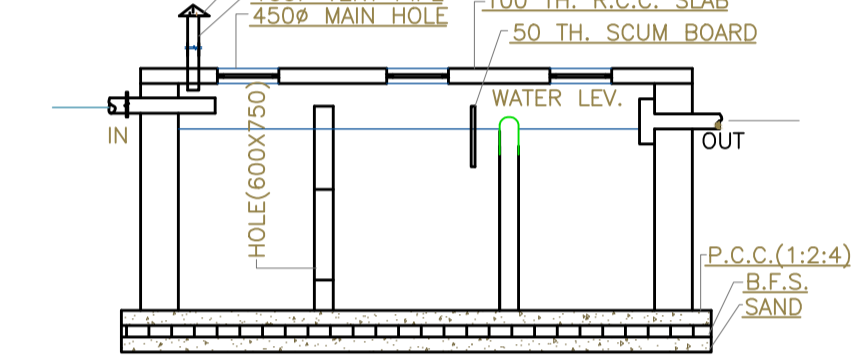

SECTION ON X-Y

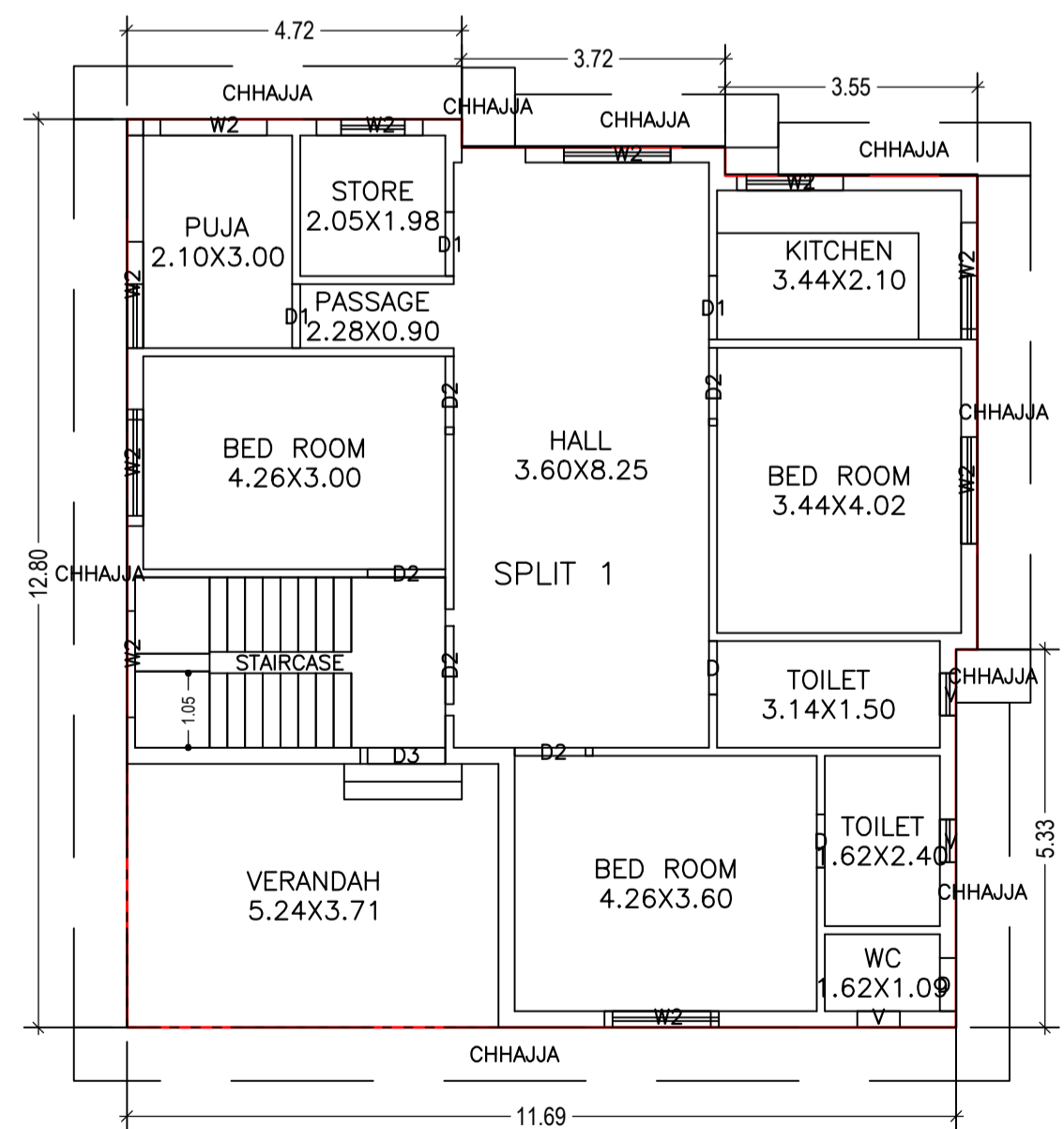

GROUND FLOOR PLAN  
(Proposed)  
(SCALE 1:100)

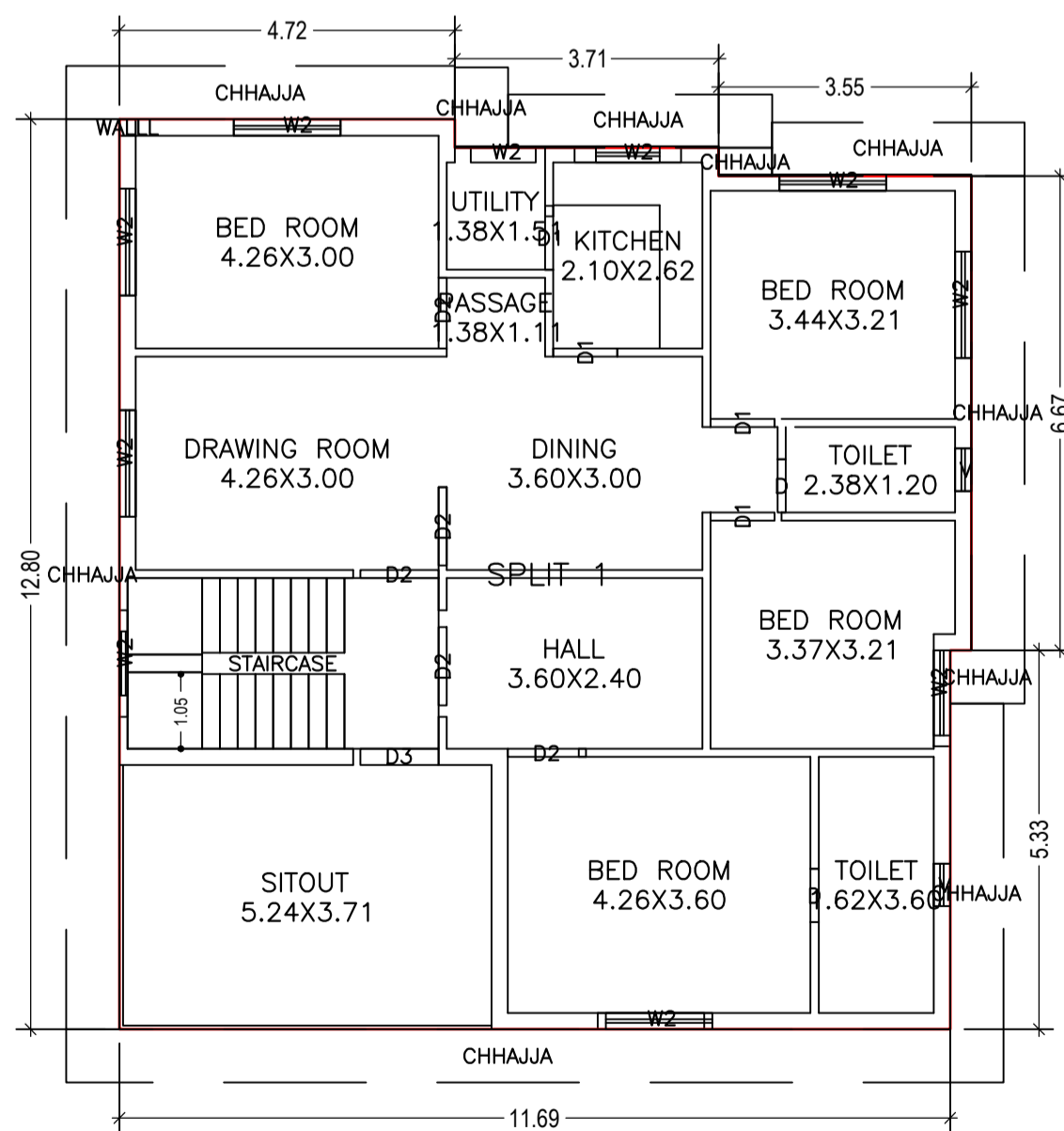

FIRST FLOOR PLAN  
(Proposed)  
(SCALE 1:100)

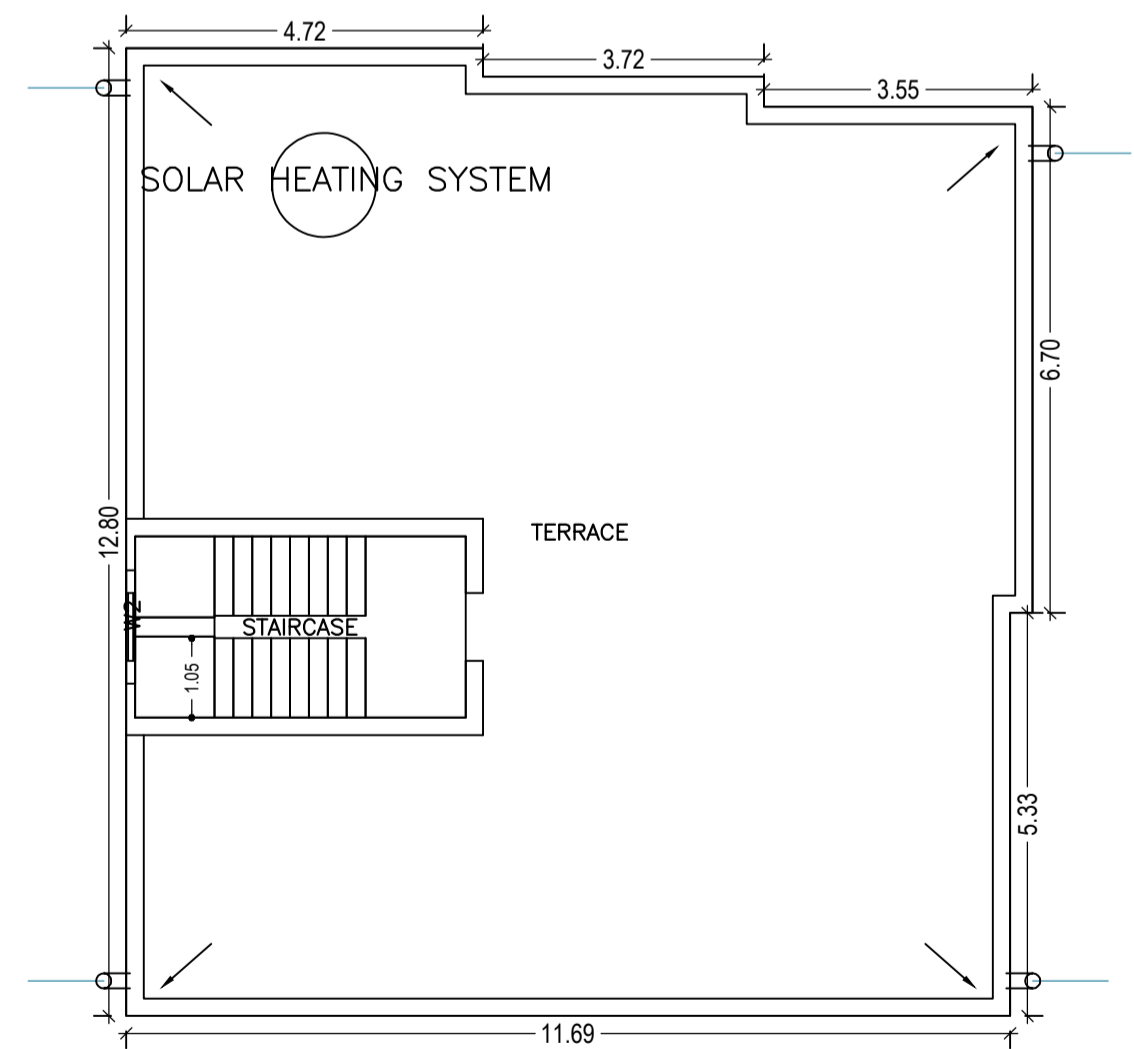

TERRACE FLOOR PLAN  
(SCALE 1:100)

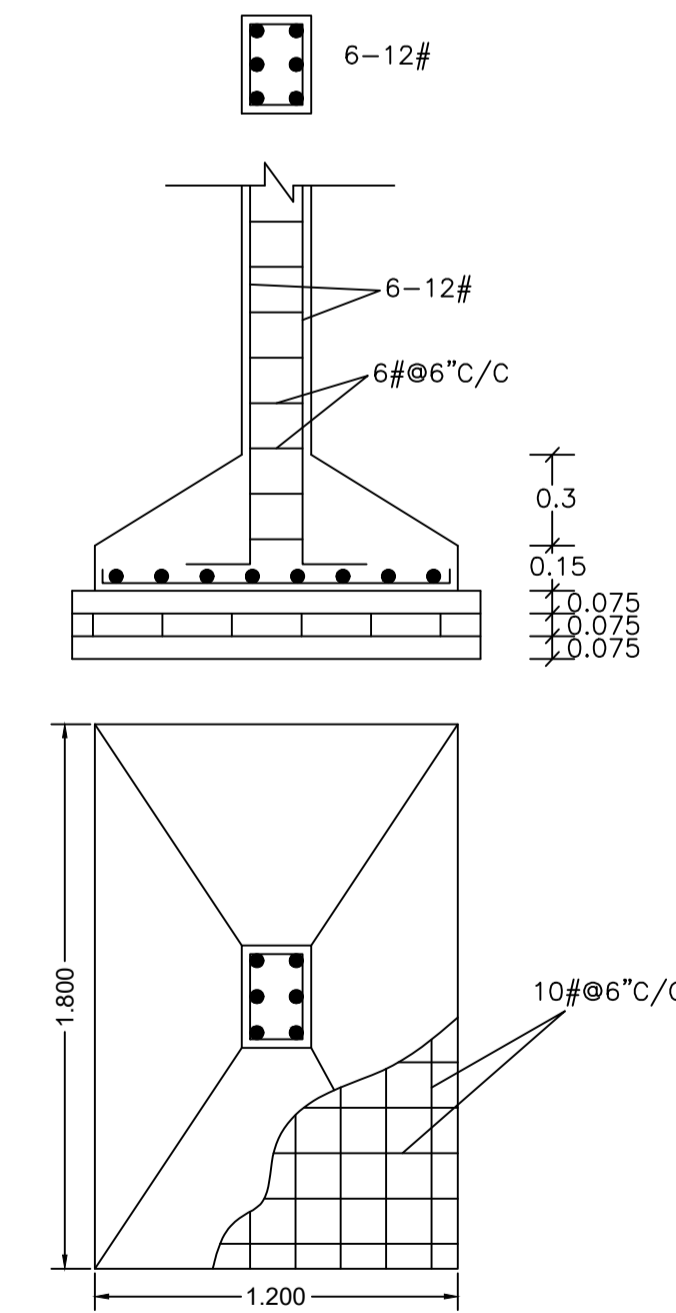

COLUMN DETAILS  
SCALE:- 1:50

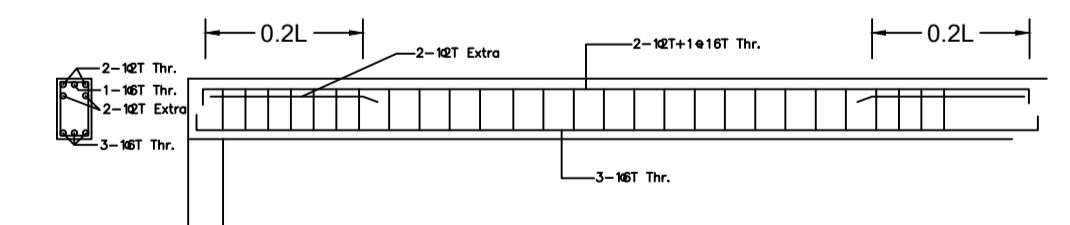

STRUCTURAL DETAILS OF BEAM

LTP NAME AND SIGNATURE	STRUCTURAL ENG'S NAME AND SIGNATURE	BUILDER NAME AND SIGNATURE	DIGITAL SIGNATURE
PARTHA - PAL DMC/ENG/0021/2016			