

SITE PLAN

SCHEDULE OF DOOR:

BUILDING NAME	NAME	LENGTH	HEIGHT	NOS
A (A P SINGH ENCLAVE)	D2	0.75	2.10	60
A (A P SINGH ENCLAVE)	D	0.90	2.10	10
A (A P SINGH ENCLAVE)	D1	0.90	2.10	30
A (A P SINGH ENCLAVE)	D	1.00	2.10	100

SCHEDULE OF WINDOW/VENTILATION:

BUILDING NAME	NAME	LENGTH	HEIGHT	NOS
A (A P SINGH ENCLAVE)	V	0.60	0.60	60
A (A P SINGH ENCLAVE)	W1	0.90	1.20	30
A (A P SINGH ENCLAVE)	W	1.20	1.20	130

Balcony Calculations Table

FLOOR	SIZE	AREA	TOTAL AREA
SECOND FLOOR PLAN	0.55 X 0.00 X 2 X 1	4.12	19.90
	0.48 X 0.00 X 2 X 1	4.12	
	1.00 X 1.77 X 2 X 1	3.50	
THIRD FLOOR PLAN	1.00 X 2.00 X 2 X 1	4.00	
	1.00 X 2.10 X 2 X 1	4.16	
	0.55 X 0.00 X 2 X 1	4.12	19.90
FOURTH FLOOR PLAN	0.48 X 0.00 X 2 X 1	4.12	
	1.00 X 1.77 X 2 X 1	3.50	
	1.00 X 2.00 X 2 X 1	4.00	
Total			59.70

UnitBUA Table for Building :A (A P SINGH ENCLAVE)

FLOOR	Name	UnitBUA Type	UnitBUA Area	Carpet Area	No. of Rooms	No. of Tenement
GROUND FLOOR PLAN	1	FLAT	76.78	76.70	7	6
	2	FLAT	76.78	76.74	7	
	3	FLAT	67.68	67.64	6	
	4	FLAT	67.12	67.07	6	
	5	FLAT	74.07	74.01	7	
	6	FLAT	76.11	76.04	7	
FIRST FLOOR PLAN	10	FLAT	67.12	67.11	6	6
	11	FLAT	74.07	74.02	7	
	12	FLAT	76.11	76.06	7	
SECOND FLOOR PLAN	7	FLAT	76.78	76.70	7	6
	8	FLAT	76.78	76.76	7	
	9	FLAT	67.68	67.66	6	
	13	FLAT	80.92	80.84	7	
	14	FLAT	80.92	80.90	7	
	15	FLAT	69.68	69.66	6	
THIRD FLOOR PLAN	16	FLAT	69.12	69.11	6	6
	17	FLAT	77.87	77.85	7	
	18	FLAT	80.22	80.20	7	
	19	FLAT	80.92	80.84	7	
	20	FLAT	80.92	80.90	7	
	21	FLAT	69.68	69.64	6	
FOURTH FLOOR PLAN	22	FLAT	69.12	69.07	6	6
	23	FLAT	77.87	77.83	7	
	24	FLAT	80.22	80.16	7	
	25	FLAT	80.92	80.84	7	
	26	FLAT	80.92	80.88	7	
	27	FLAT	69.68	69.66	6	
Total			2253.25	2252.00	200	30

Building :A (A P SINGH ENCLAVE)

Floor Name	Gross Builtup Area	Deductions From Gross BUA/Area in Sq.m.	Total Built Up Area (Sq.m.)	Deductions (Area in Sq.m.)			Proposed FAR Area (Sq.m.)	Add Area In FAR (Sq.m.)	Total FAR Area (Sq.m.)	Total Consumed Additional FAR Area (Sq.m.)	Trmt (No.)
				Cutout	Lift	Balcony					
Basement Floor	557.68	15.28	542.40	0.00	0.00	533.98	0.00	8.42	8.42	8.42	00
Ground Floor	489.55	15.28	474.27	0.00	0.00	0.00	474.27	0.00	474.27	474.27	06
First Floor	489.55	15.28	474.27	0.00	0.00	0.00	474.27	0.00	474.27	474.27	06
Second Floor	509.74	15.28	494.46	0.00	10.10	0.00	484.36	0.00	484.36	484.36	06
Third Floor	509.74	15.28	494.46	0.00	10.10	0.00	484.36	0.00	484.36	484.36	06
Fourth Floor	509.75	0.00	509.75	6.86	10.10	0.00	492.79	0.00	492.79	492.79	06
Terrace Floor	0.00	0.00	0.00	0.00	0.00	0.00	0.00	0.00	0.00	0.00	00
Total :	3066.01	76.40	2989.61	6.86	30.30	533.98	2410.05	8.42	2418.47	2418.47	30
Total Number of Same Buildings :	1										
Total :	3066.01	76.40	2989.61	6.86	30.30	533.98	2410.05	8.42	2418.47	2418.47	30

Required Parking (Table 7a)

Building Name	Type	SubUse	Area (Sq.m.)	Units		Car		Visitors Car		TwoWheeler	
				Reqd.	Prop.	Reqd./Unit	Prop.	Reqd./Unit	Prop.	Reqd./Unit	Prop.
A (A P SINGH ENCLAVE)	Residential	Residential Bldg/Apartment	0 - 140	1	30.00	1.00	30	-	-	-	-
A (A P SINGH ENCLAVE)			> 140	1	30.00	-	-	-	-	1	30
A (A P SINGH ENCLAVE)			> 0	1	30.00	-	-	1	3	-	-
Total :			-	-	-	-	30	30	3	3	30

Parking Check (Table 7b)

Vehicle Type	Reqd.		Prop.	
	No.	Area	No.	Area
Car	-	-	30	375.00
Total Car	30	375.00	30	375.00
Visitor's Car Parking	-	-	3	37.50
Total Visitor Parking	3	37.50	3	37.50
TwoWheeler	-	-	30	60.00
Total TwoWheeler	30	60.00	30	60.00
Other Parking	-	-	-	276.76
Total		472.50		846.76

FAR & Tenement Details (Table 4c-1)

Building	No. of Same Bldg	Gross Built Up Area (Sq.m.)	Deductions From Gross BUA/Area in Sq.m.	Total Built Up Area (Sq.m.)	Deductions (Area in Sq.m.)		Proposed FAR Area (Sq.m.)	Add Area In FAR (Sq.m.)	Total FAR Area (Sq.m.)	Total Consumed Additional FAR Area (Sq.m.)	Trmt (No.)	
					Lift	Balcony						Parking
A (A P SINGH ENCLAVE)	1	3066.01	76.40	2989.61	6.86	30.30	533.98	2410.05	8.42	2418.47	2418.47	30
Grand Total :	1	3066.01	76.40	2989.61	6.86	30.30	533.98	2410.05	8.42	2418.47	2418.47	30

LTP NAME AND SIGNATURE	STRUCTURAL ENG'S NAME AND SIGNATURE	BUILDER NAME AND SIGNATURE	DIGITAL SIGNATURE
PIYUSH KANTI SINGH DMC/ENG/0202016			

Proposal Basic Information	
Proposal File No.	DMC/BP/0250/W20/2019
Owner Name	Sri. Shailesh Kumar Singh and Others
Khata No	26 , New Khata No. - 1
Plot No	90 , 93 ,New Plot - 162
Village Name	Bisanpur
Use	Residential
SubUse	Residential Bldg/Apartment

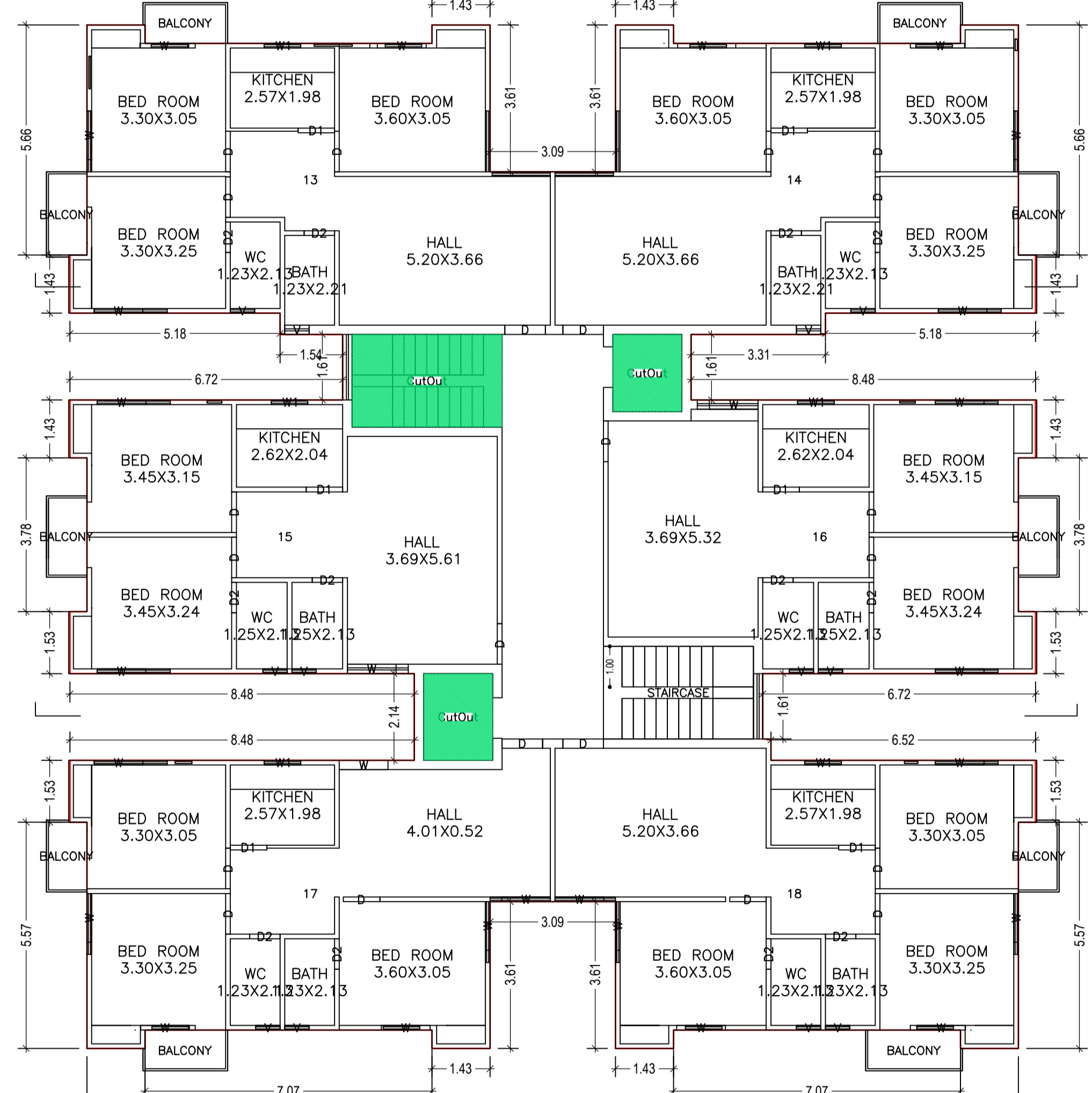
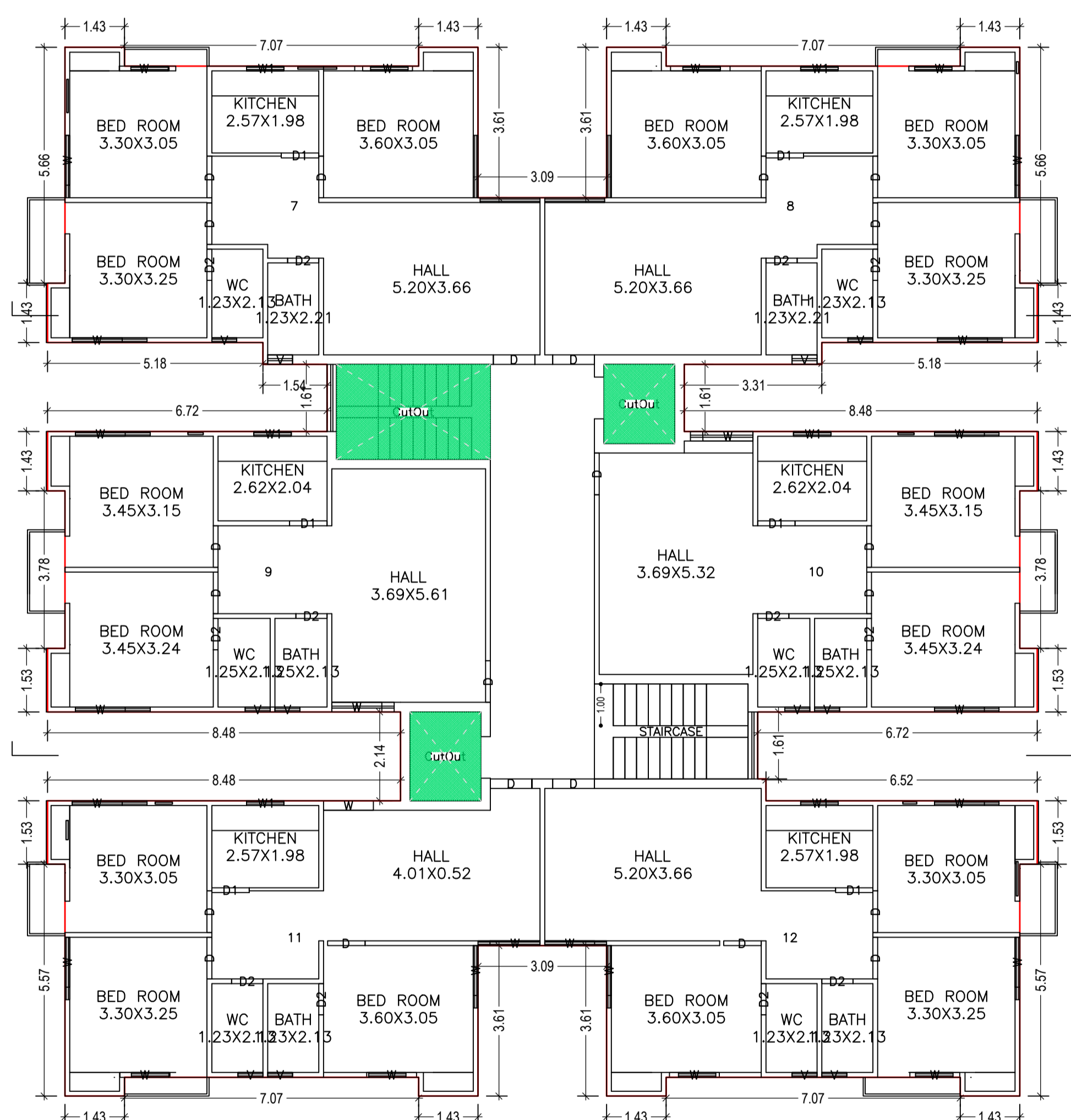

LTP NAME AND SIGNATURE	STRUCTURAL ENG'S NAME AND SIGNATURE	BUILDER NAME AND SIGNATURE	DIGITAL SIGNATURE
PIYUSH KANTI SINGH DMC/ENG/0020/2016			

Proposal Basic Information	
Proposal File No.	DMC/BP/0250/W20/2019
Owner Name	Sri. Shailesh Kumar Singh and Others
Khata No	26 , New Khata No. - 1
Plot No	90 , 93 ,New Plot - 162
Village Name	Bisanpur
Use	Residential
SubUse	Residential Bldg/Apartment

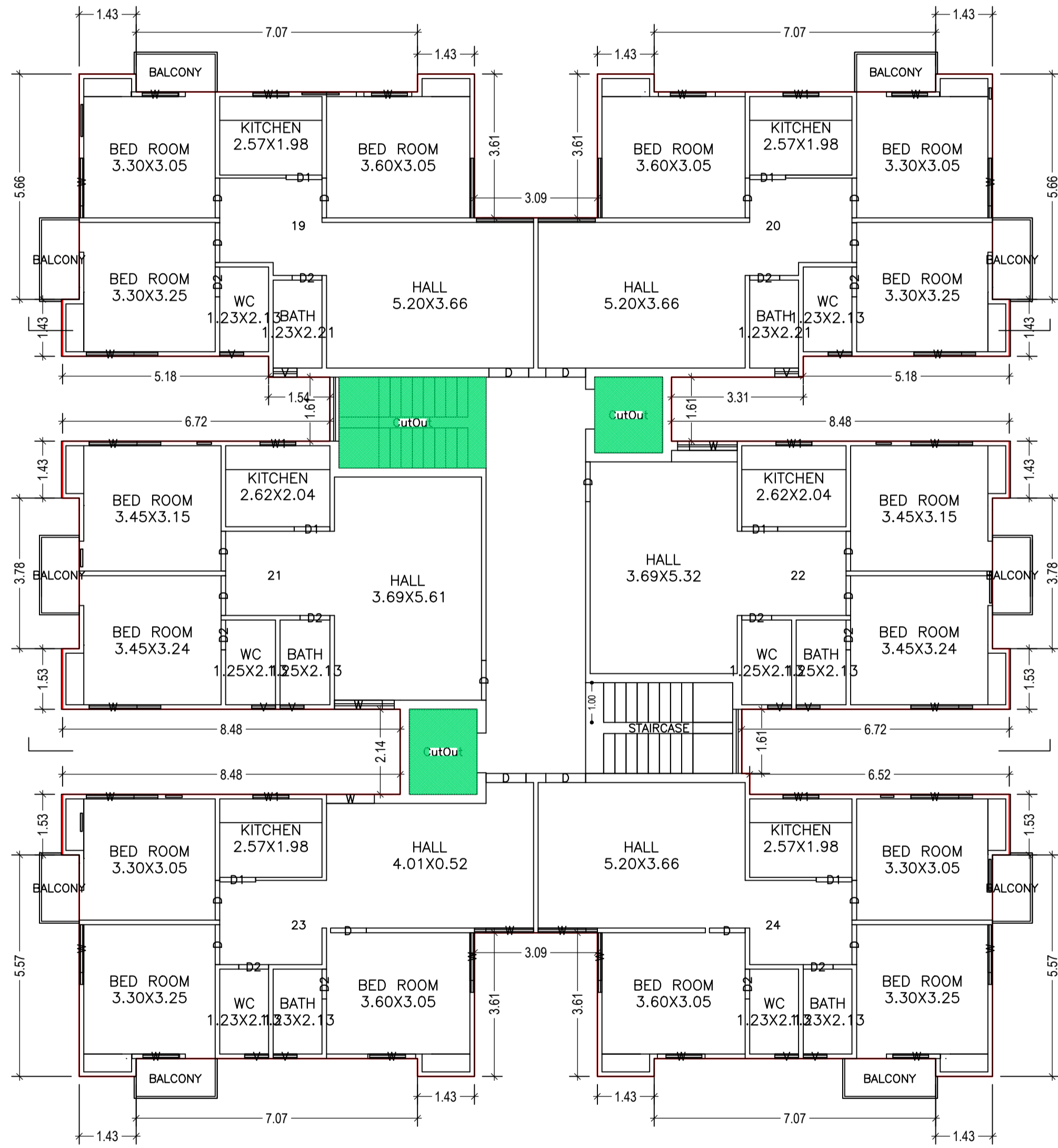

THIRD FLOOR PLAN
(Proposed)
(SCALE 1:100)

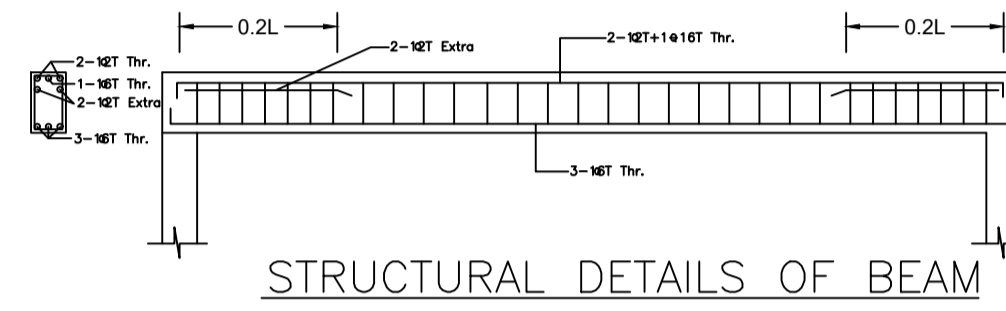

STRUCTURAL DETAILS OF BEAM

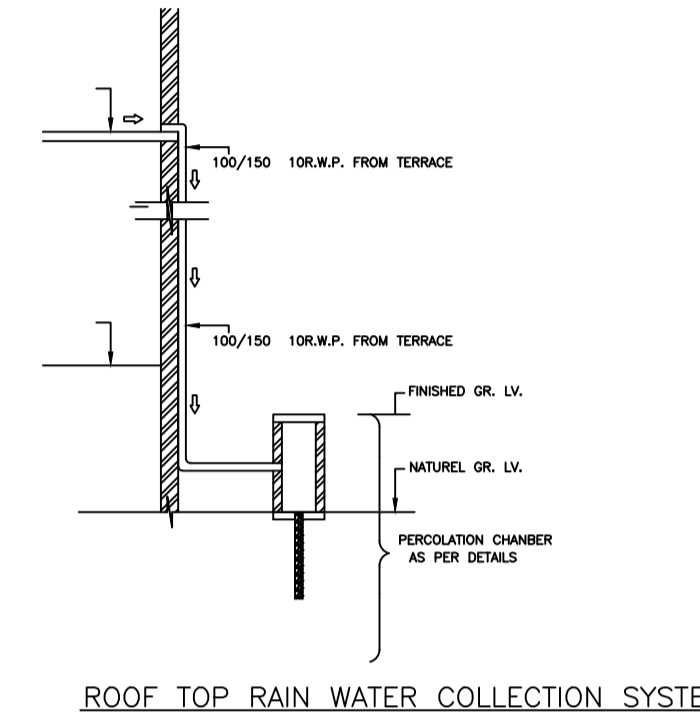

ROOF TOP RAIN WATER COLLECTION SYSTEM

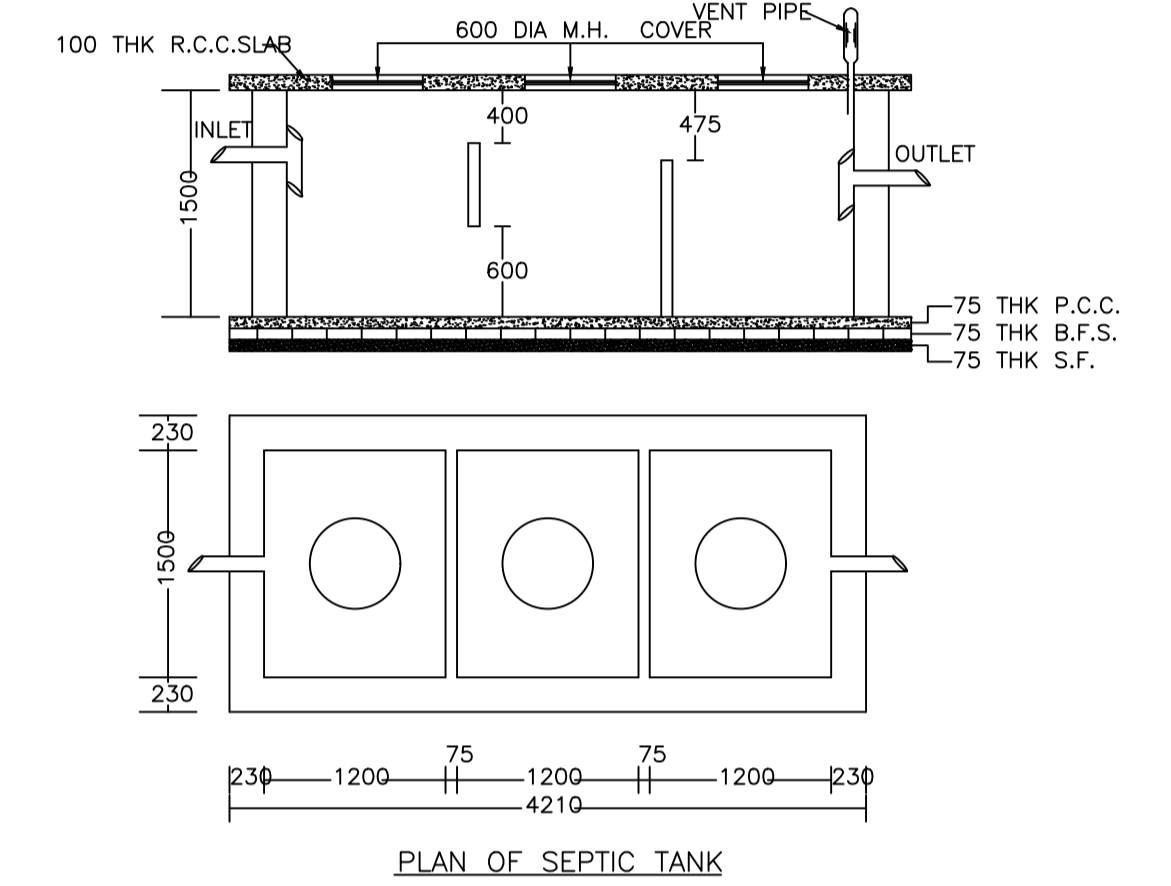

PLAN OF SEPTIC TANK

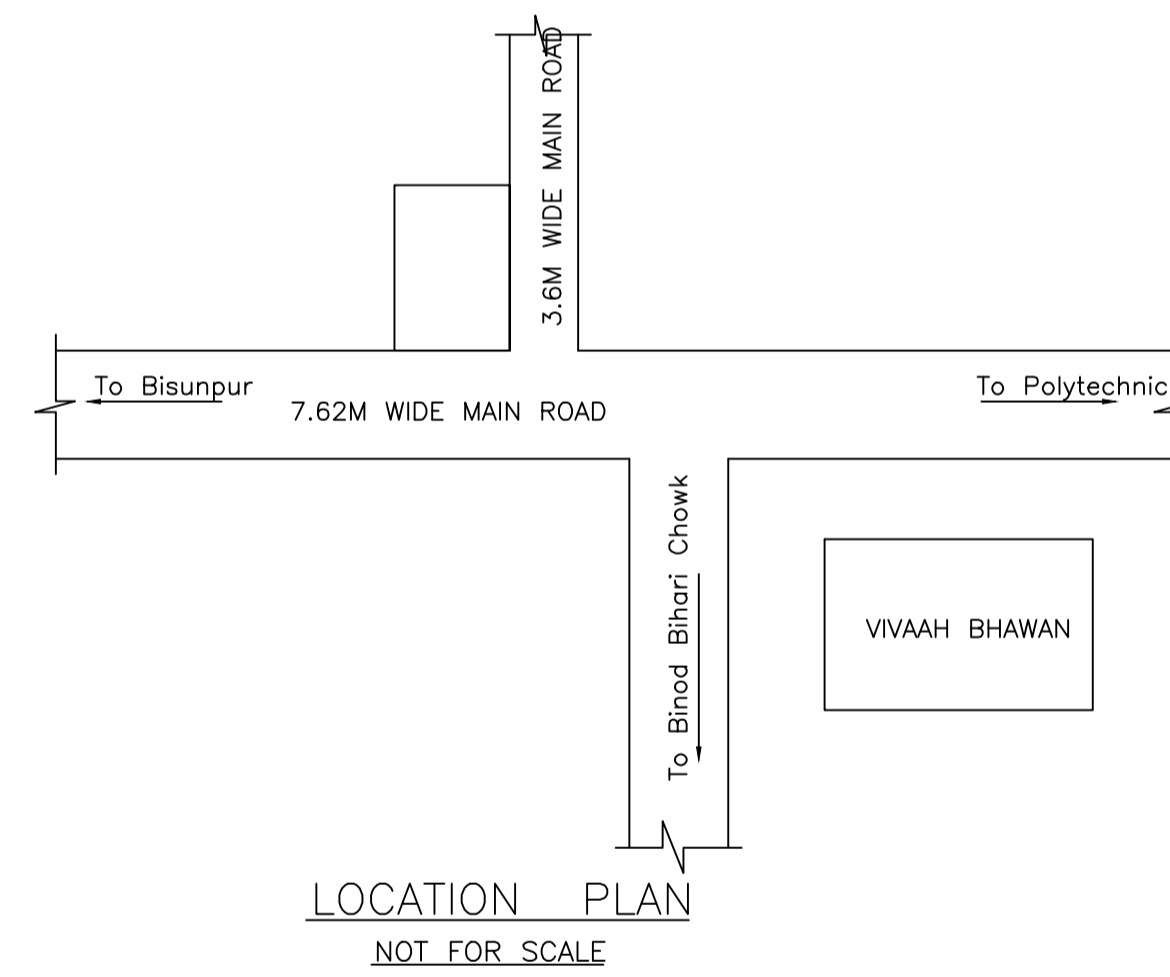

LOCATION PLAN
NOT FOR SCALE

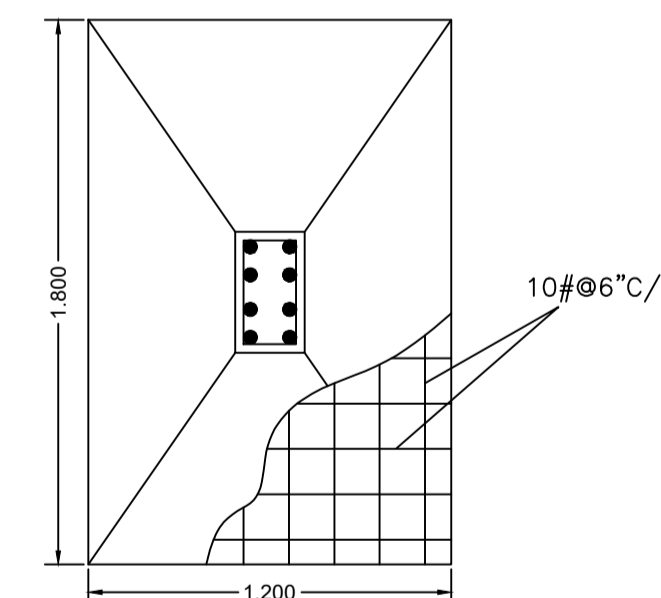
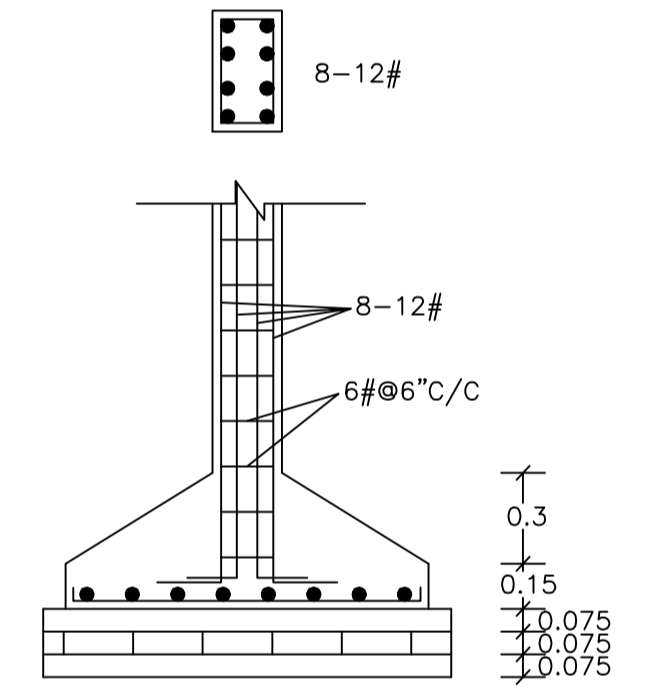

COLUMN DETAILS
SCALE:- 1:50
PART OF PLOT NO.93

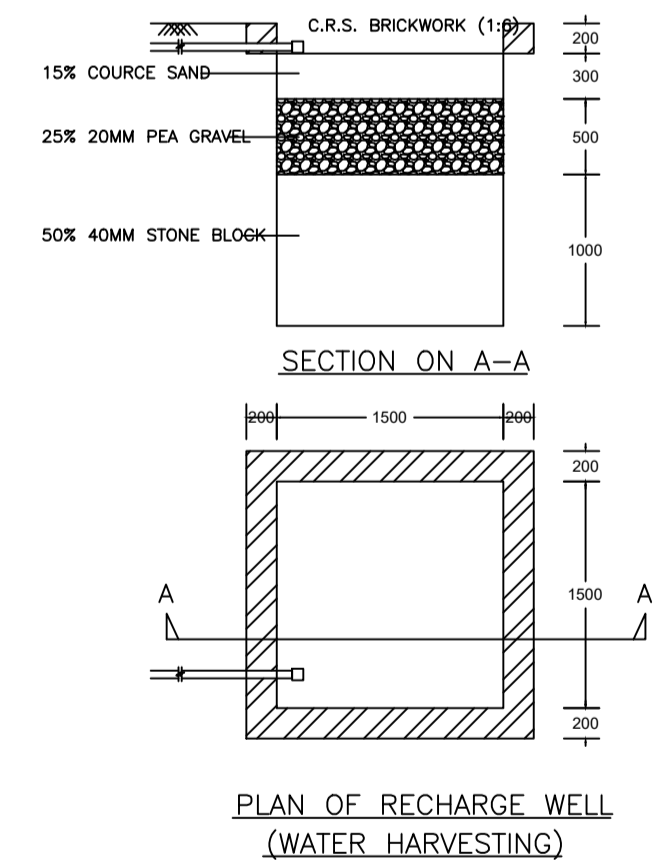
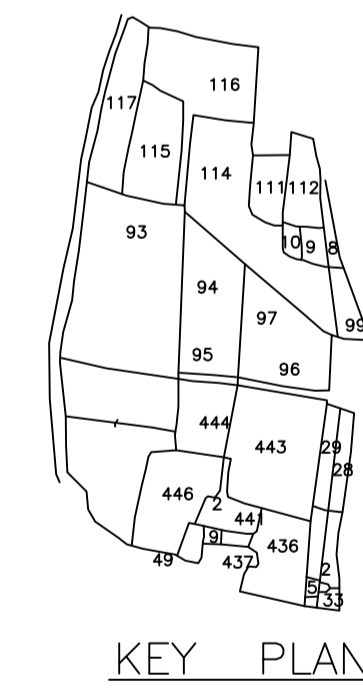

LTP NAME AND SIGNATURE	STRUCTURAL ENG'S NAME AND SIGNATURE	BUILDER NAME AND SIGNATURE	DIGITAL SIGNATURE
PIYUSH KANTI SINGH DMC/ENG/0020/2016			

Proposal Basic Information	
Proposal File No.	DMC/BP/0250/W20/2019
Owner Name	Sri. Shailesh Kumar Singh and Others
Khata No	26 , New Khata No. - 1
Plot No	90 , 93 ,New Plot - 162
Village Name	Bisanpur
Use	Residential
SubUse	Residential Bldg/Apartment

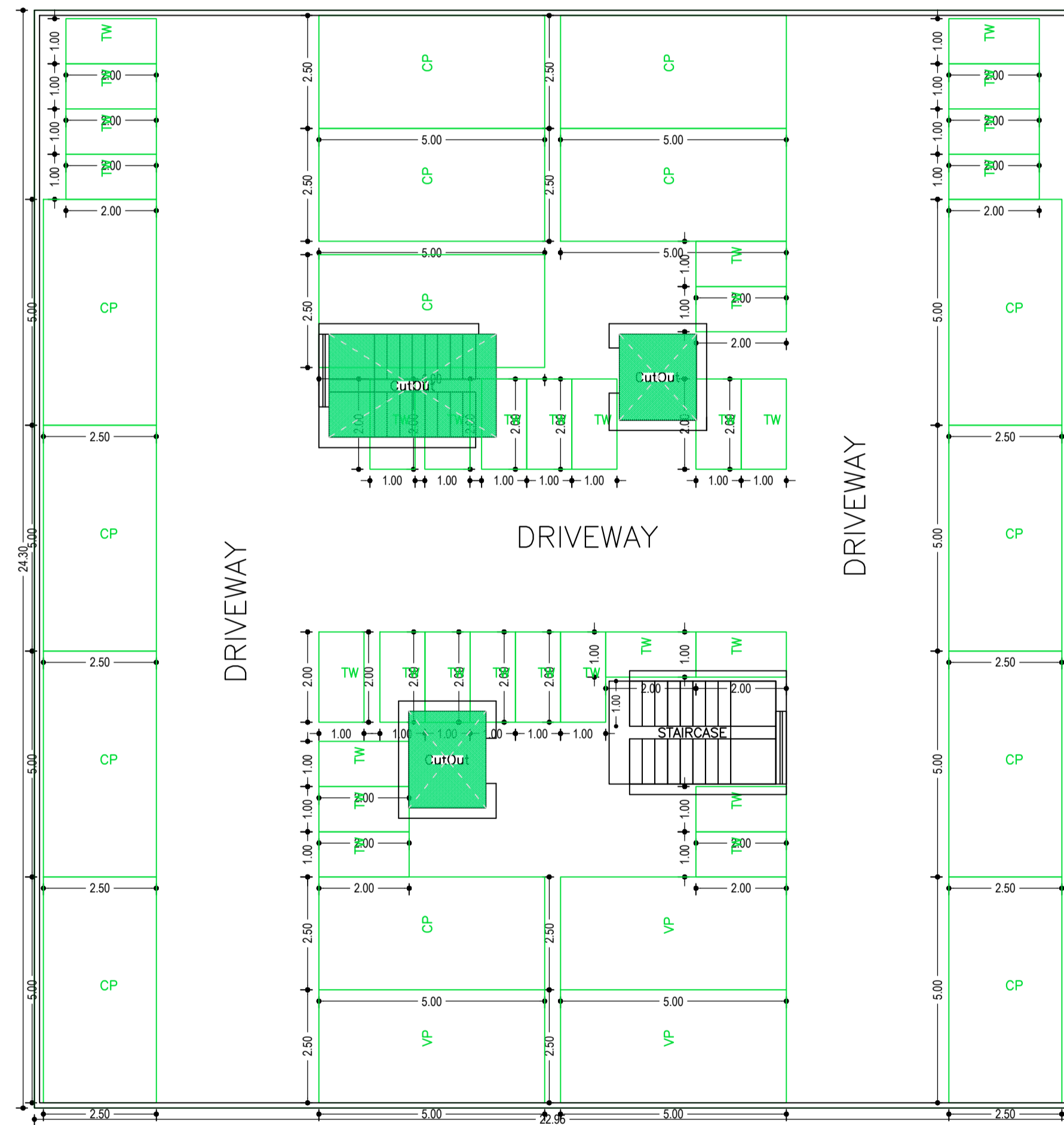

BASEMENT FLOOR PLAN
(SCALE 1:100)

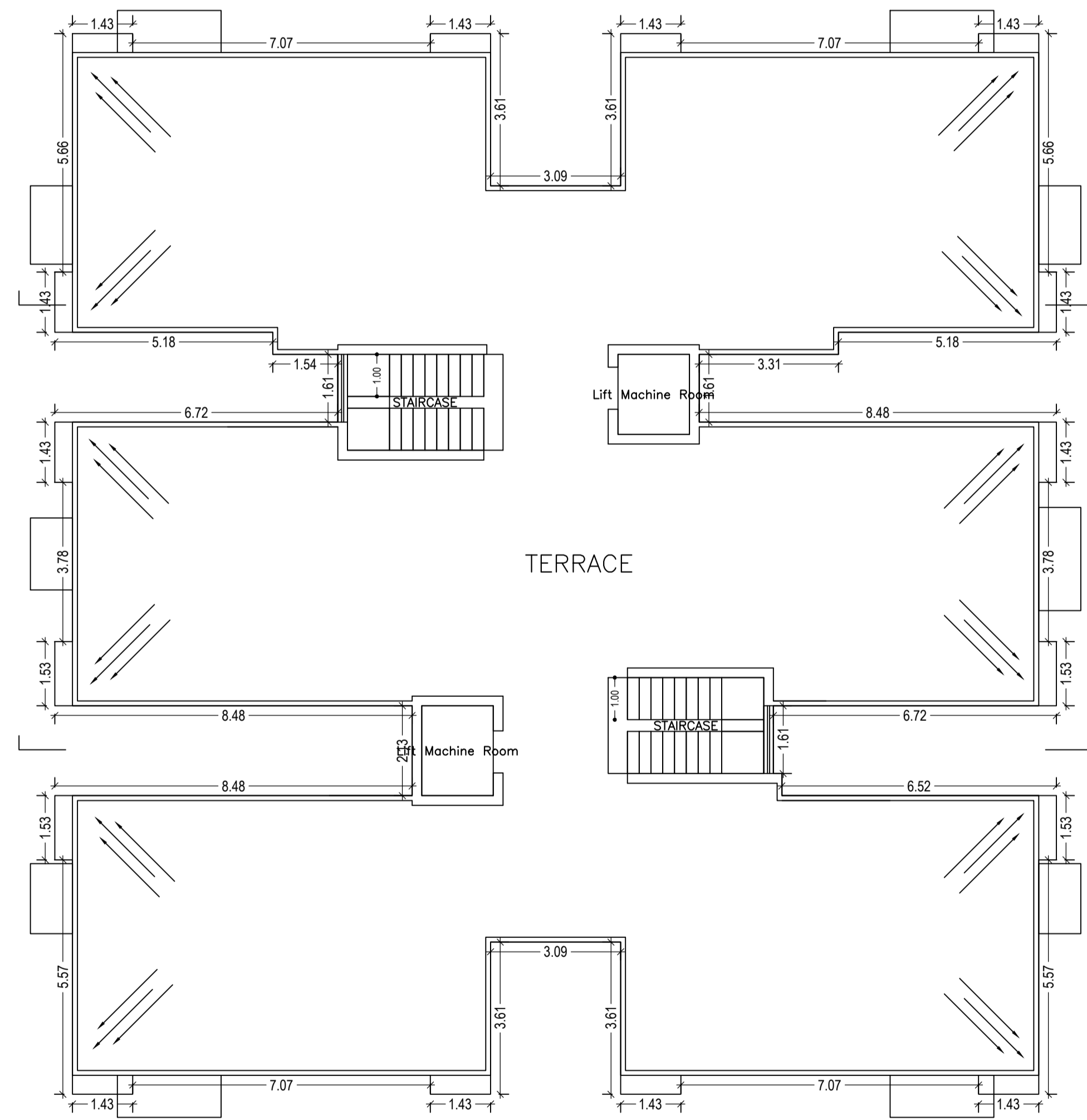

TERRACE FLOOR PLAN
(SCALE 1:100)

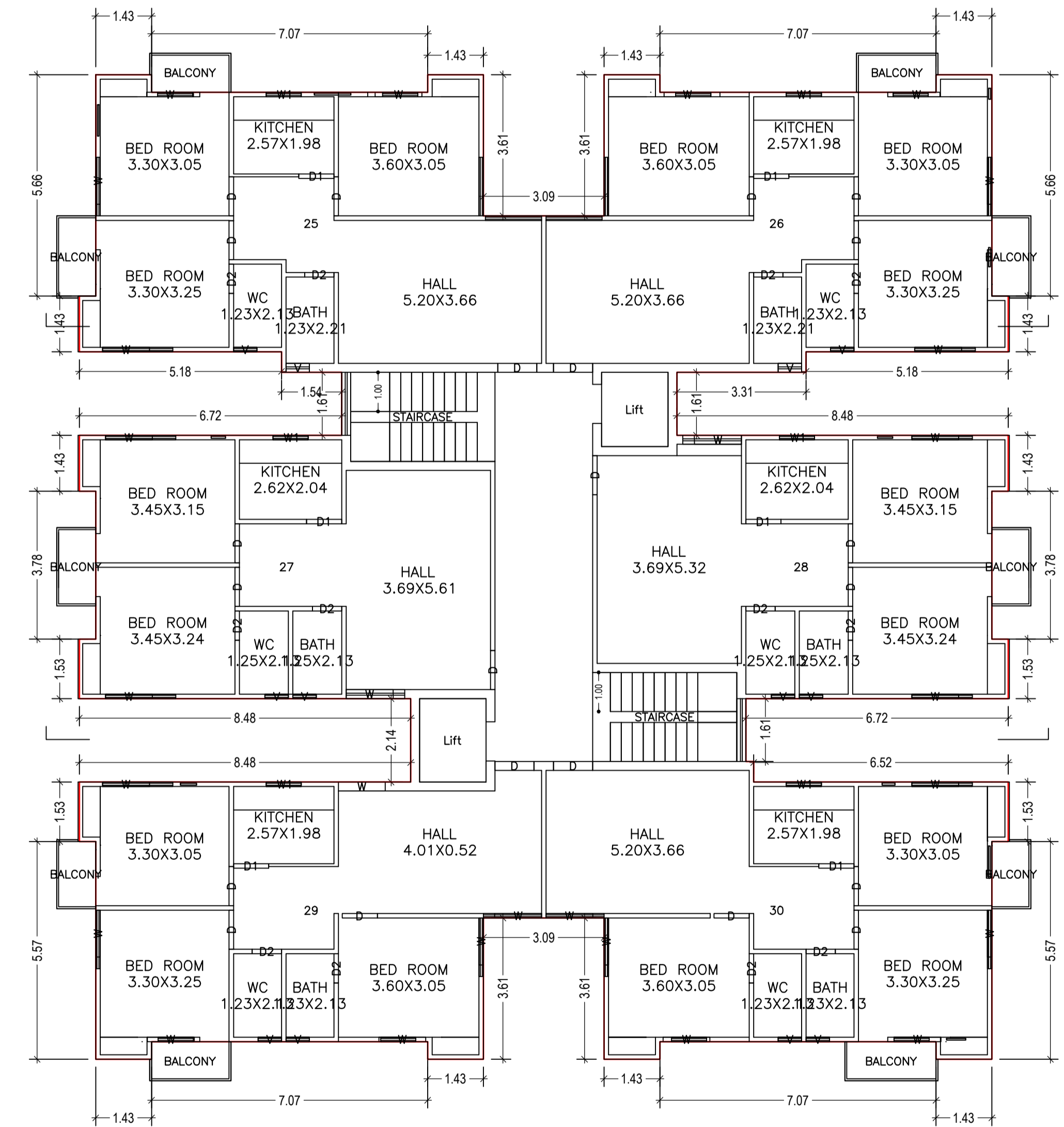

FOURTH FLOOR PLAN
(Proposed)
(SCALE 1:100)

LTP NAME AND SIGNATURE	STRUCTURAL ENG'S NAME AND SIGNATURE	BUILDER NAME AND SIGNATURE	DIGITAL SIGNATURE
PIYUSH KANTI SINGH DMC/ENG/0020/2016			

Proposal Basic Information	
Proposal File No.	DMC/BPI0250/W20/2019
Owner Name	Sri. Shailesh Kumar Singh and Others
Khata No	26 , New Khata No. - 1
Plot No	90 , 93 ,New Plot - 162
Village Name	Bisanpur
Use	Residential
SubUse	Residential Bldg/Apartment

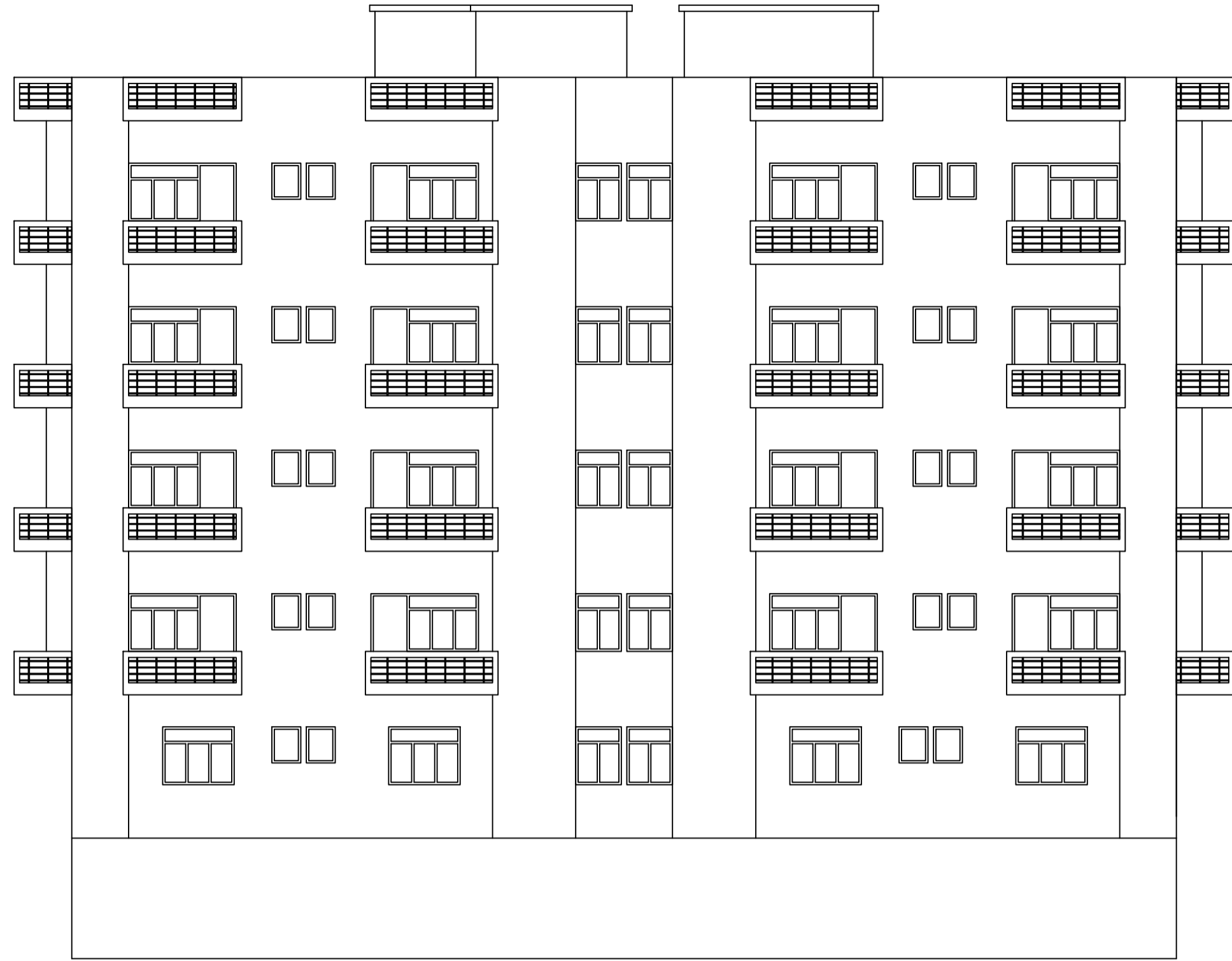

FRONT ELEVATION



RIGHT SIDE ELEVATION

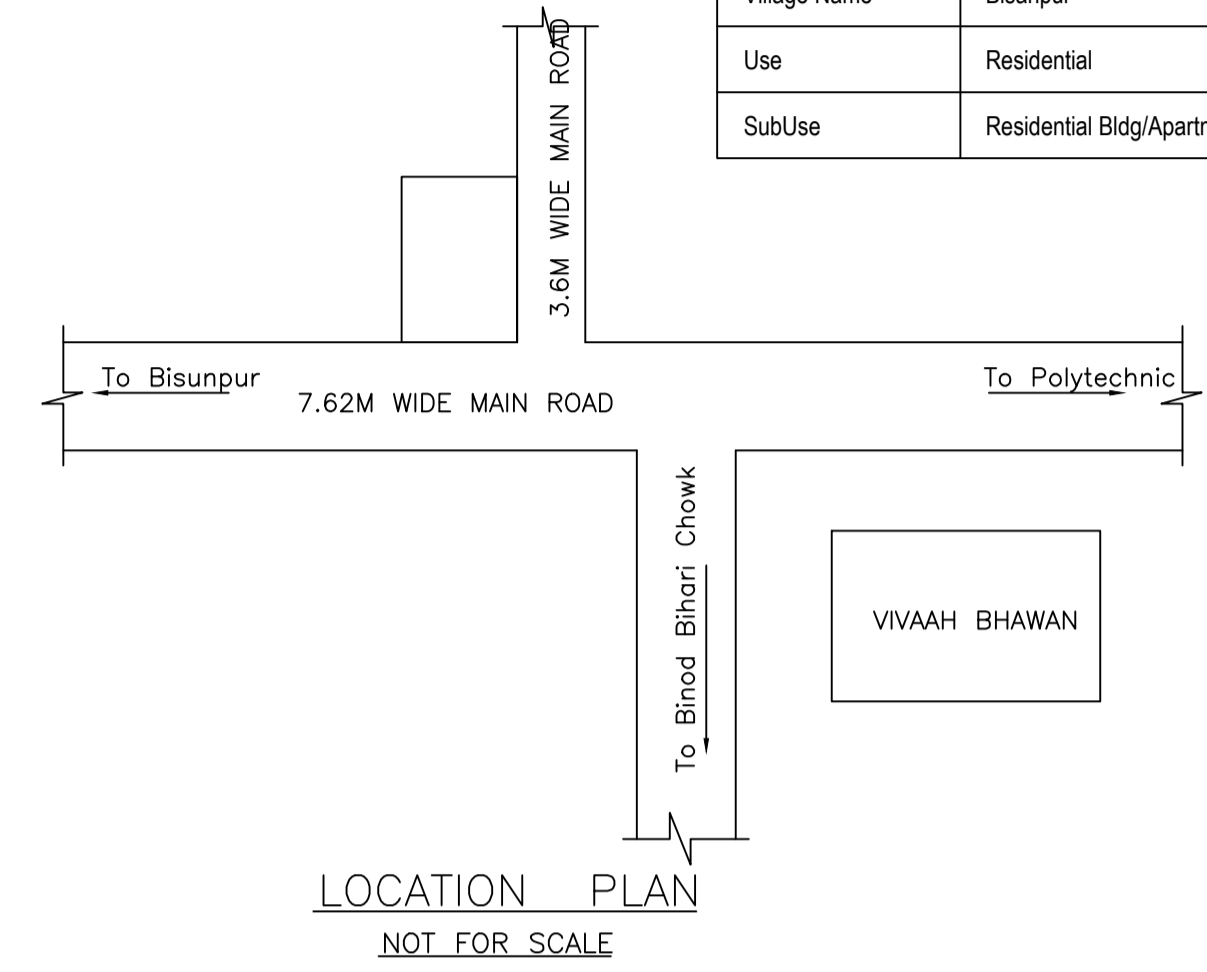

LOCATION PLAN
NOT FOR SCALE

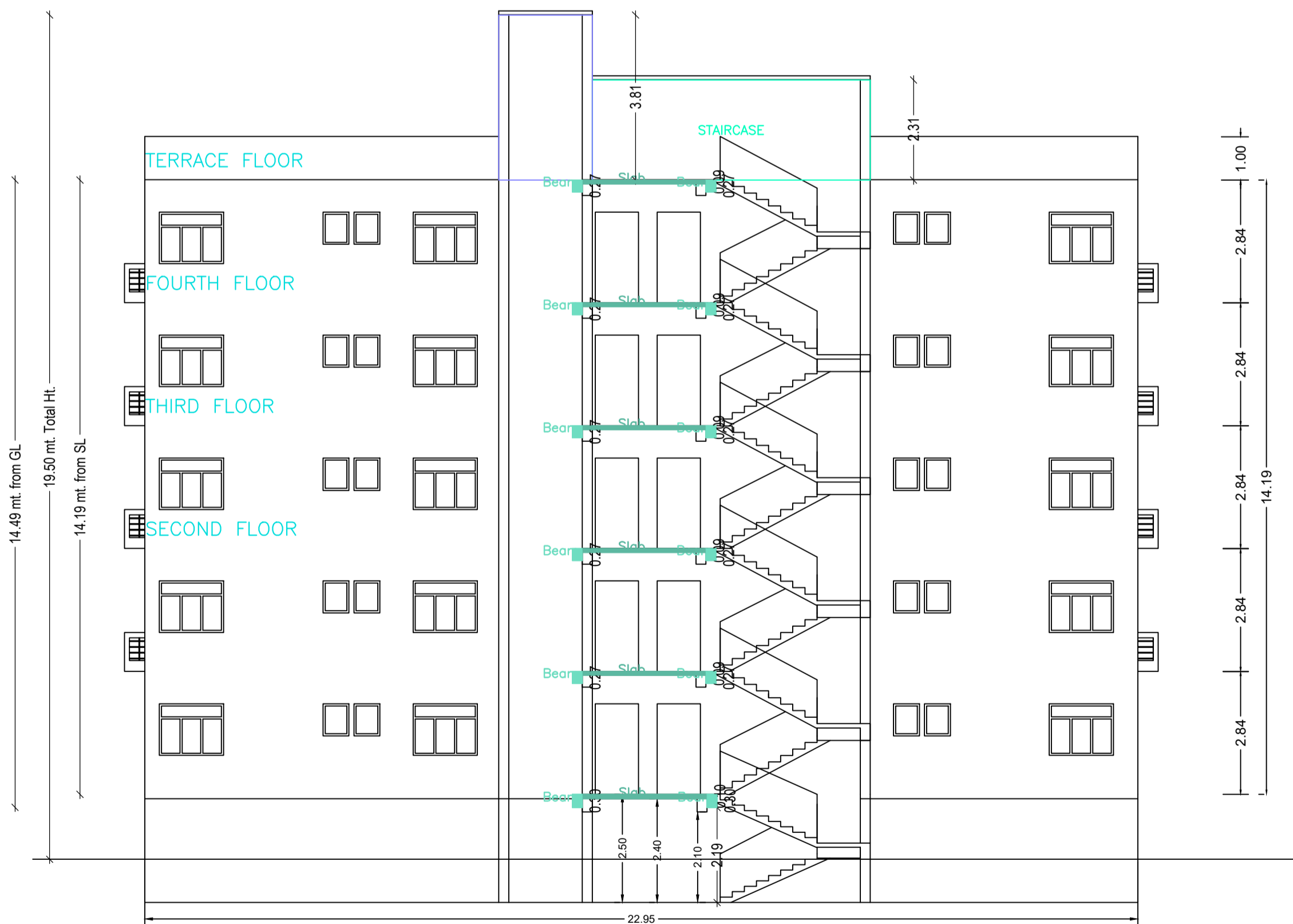

SECTION ON X-X

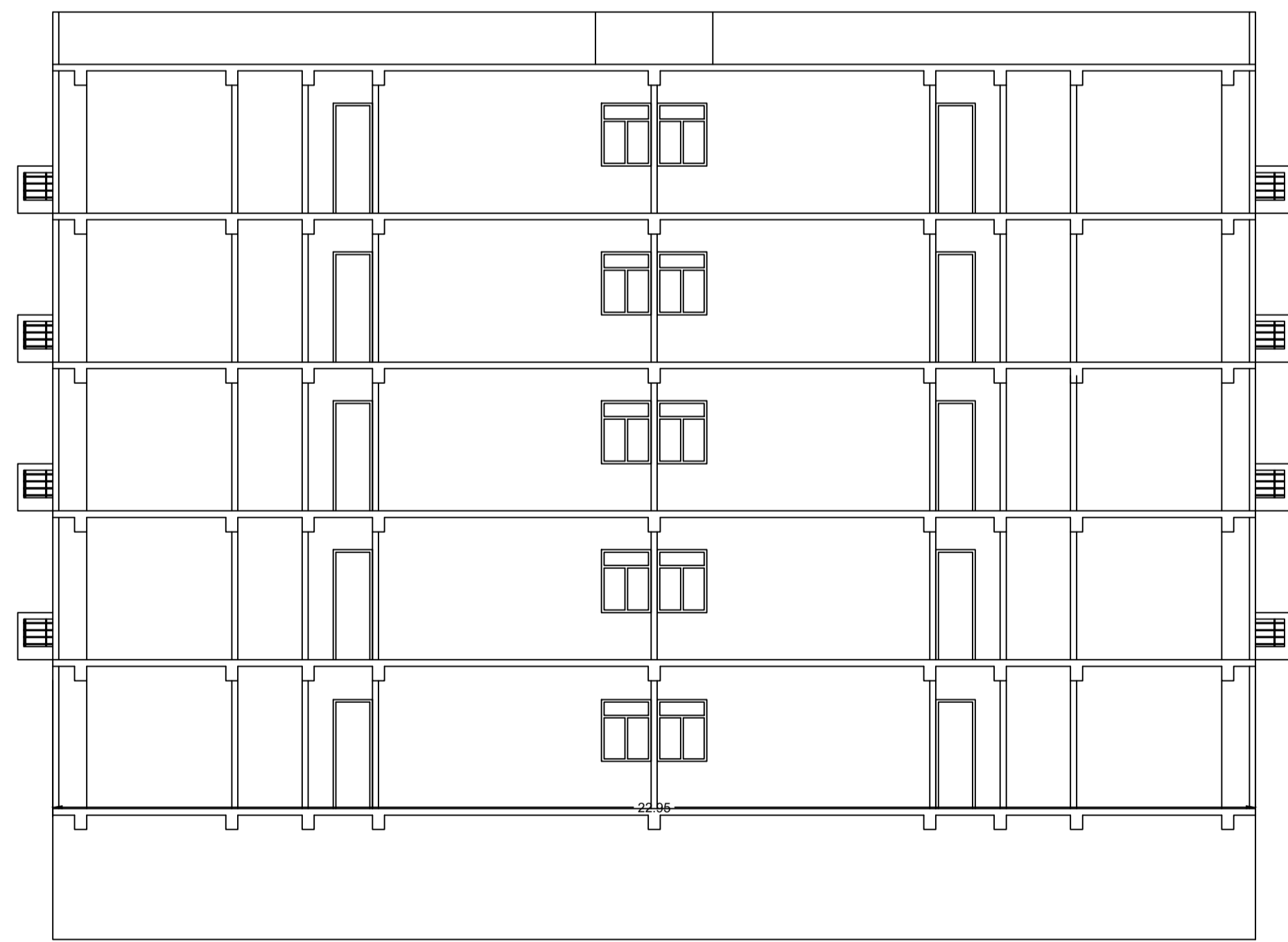

SECTION ON Y-Y

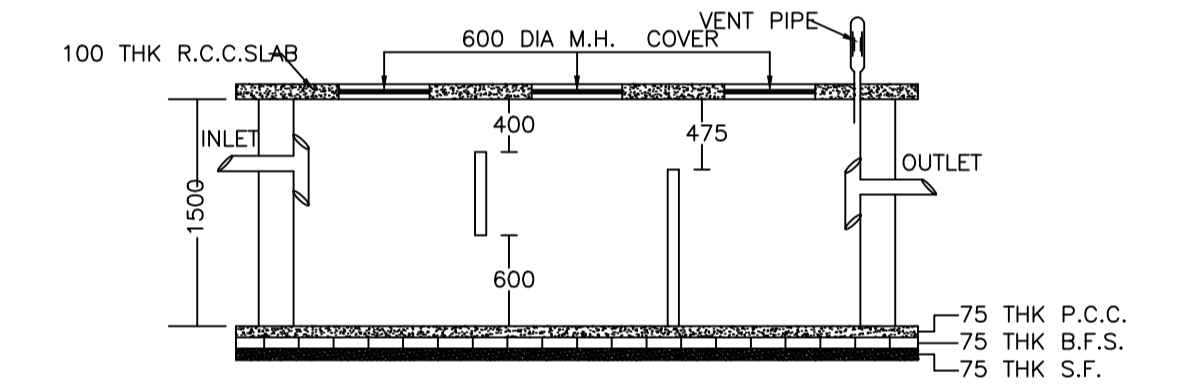

PLAN OF SEPTIC TANK

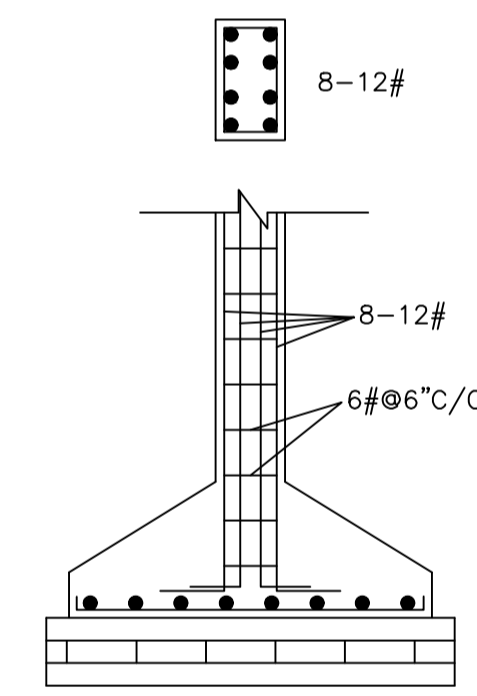

COLUMN DETAILS
SCALE:- 1:50

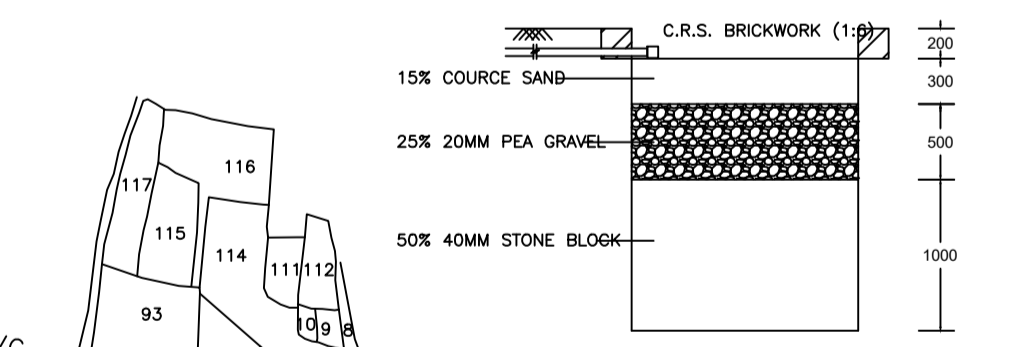

SECTION A-A

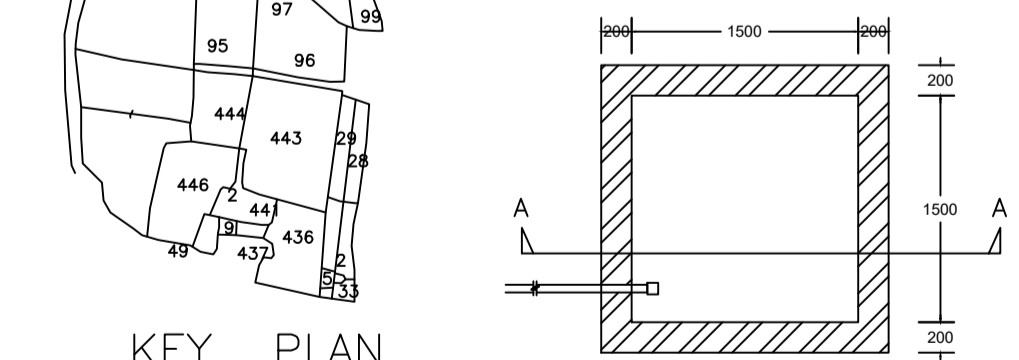

PLAN OF RECHARGE WELL
(WATER HARVESTING)

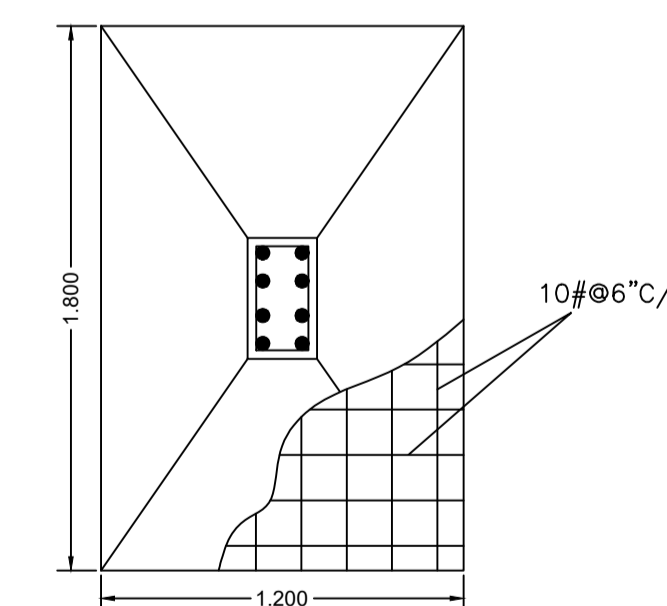

KEY PLAN

PART OF PLOT NO.93

LTP NAME AND SIGNATURE	STRUCTURAL ENG'S NAME AND SIGNATURE	BUILDER NAME AND SIGNATURE	DIGITAL SIGNATURE
PIYUSH KANTI SINGH DMC/ENG/0020/2016			