

| Proposal Basic Information | |
|----------------------------|---|
| Proposal File No. | DMC/BP/0355/W23/2019 |
| Owner Name | KOUSHALYA DEVI |
| Khata No | OLD KHATA NO. 131(NEW KHATA NO. 552) |
| Plot No | OLD PLOT NO. - 3329 (NEW - 4035, 4910) |
| Village Name | Kolakusma |
| Use | Residential |
| SubUse | Bungalow/ Dwelling / Non Apartment |

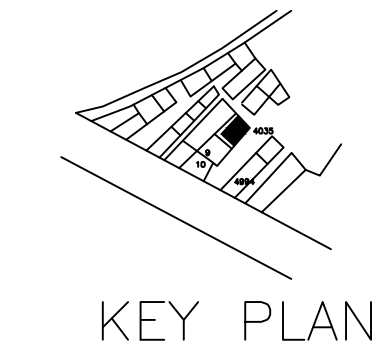
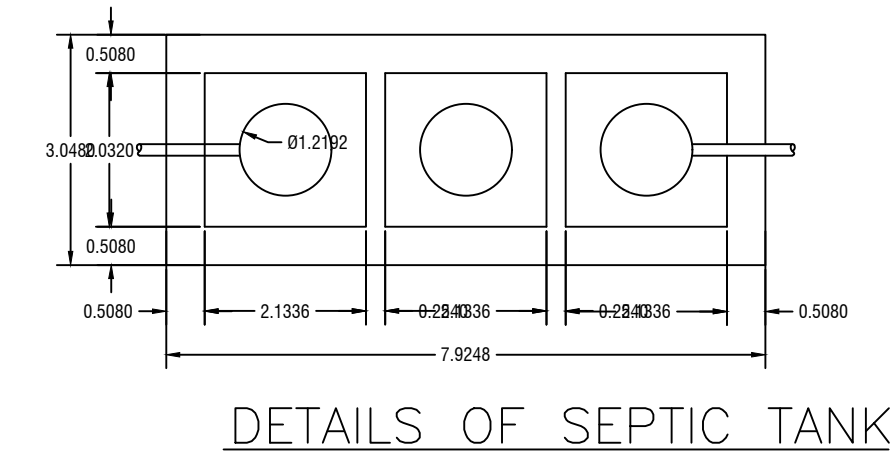
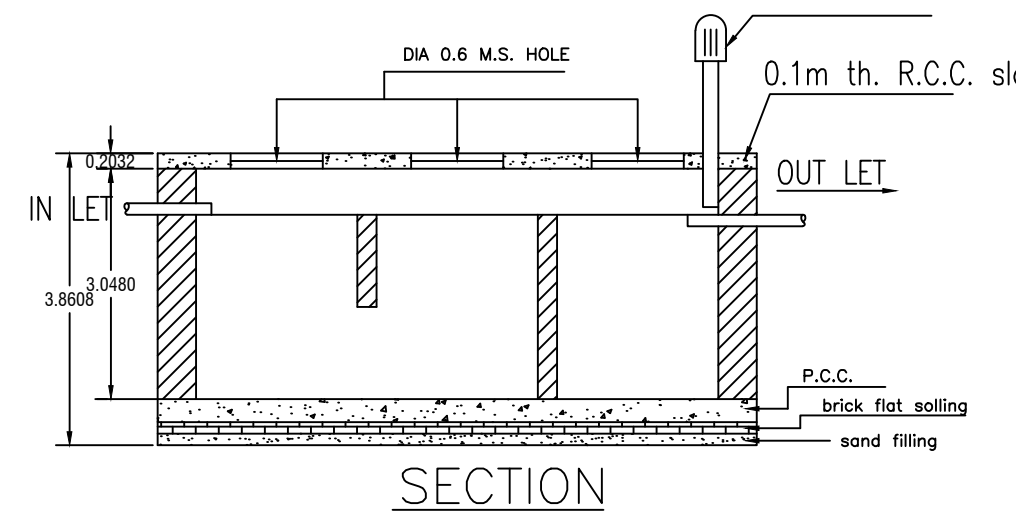
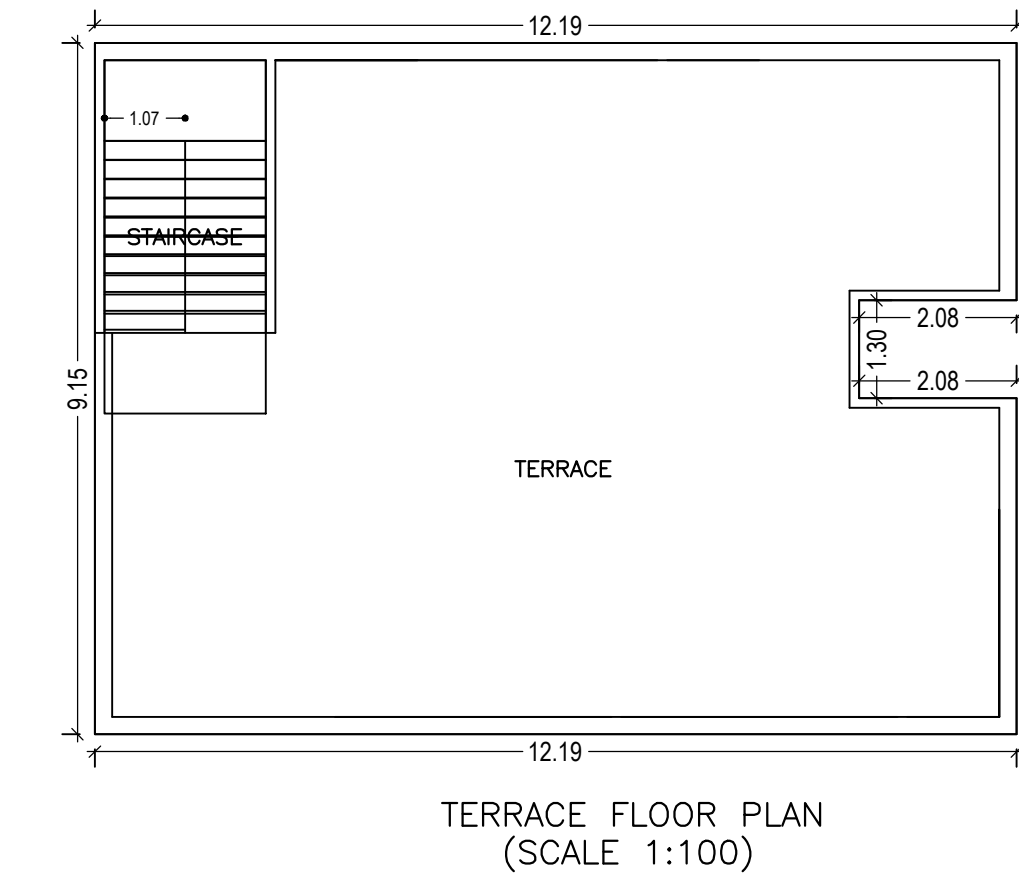
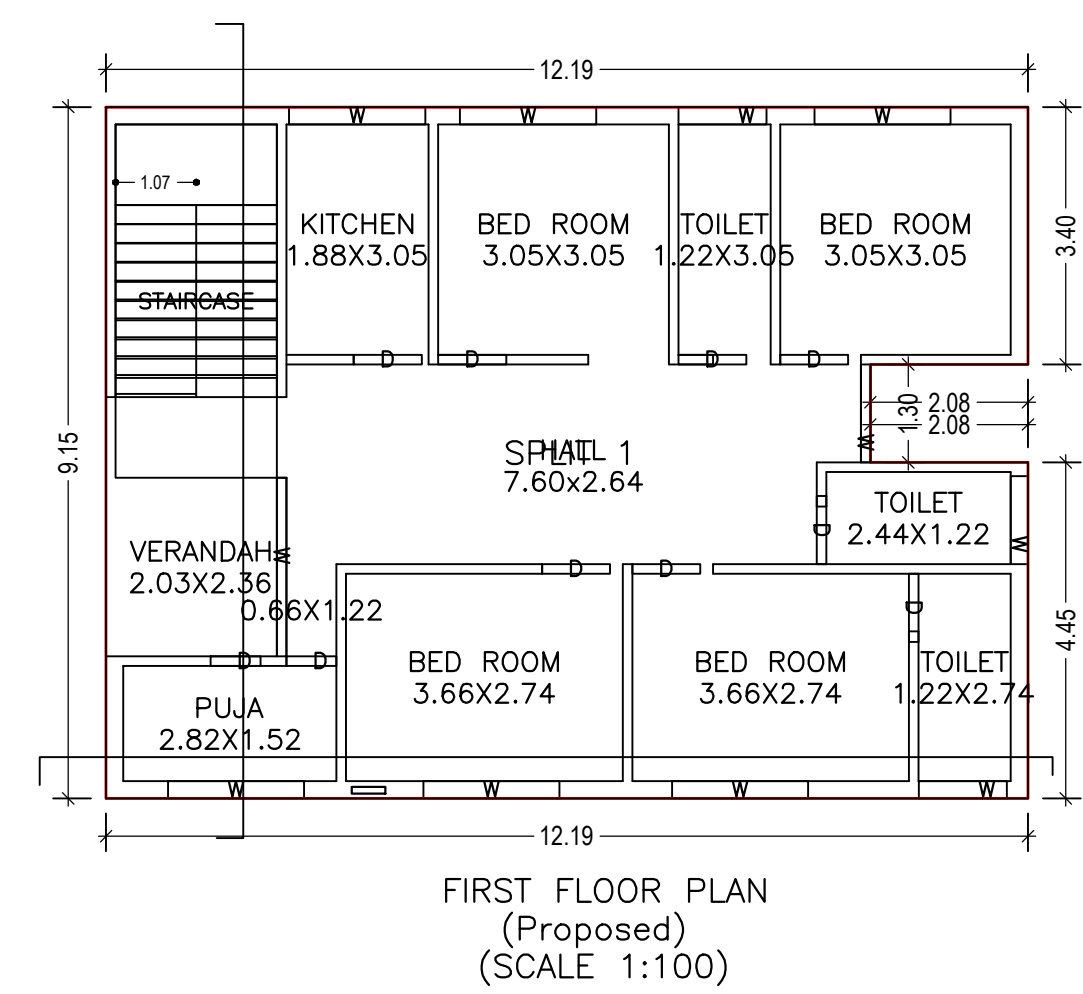
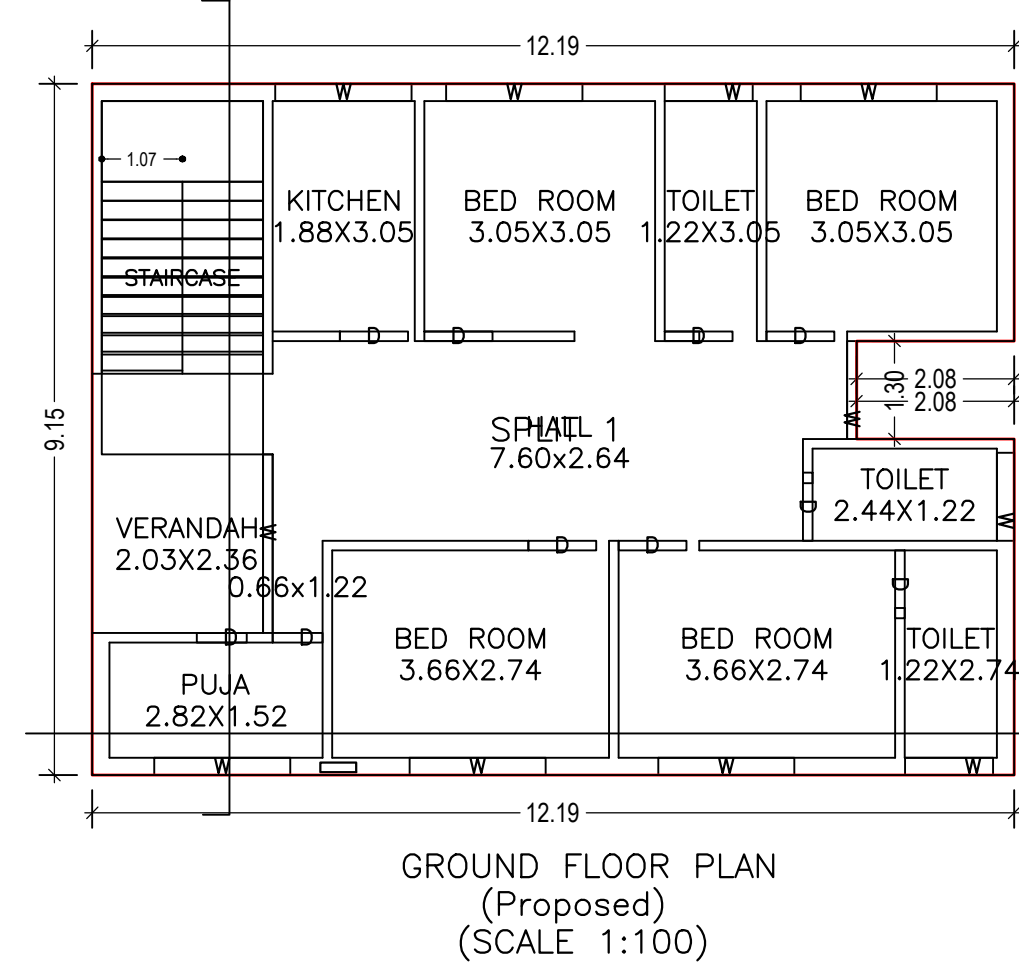
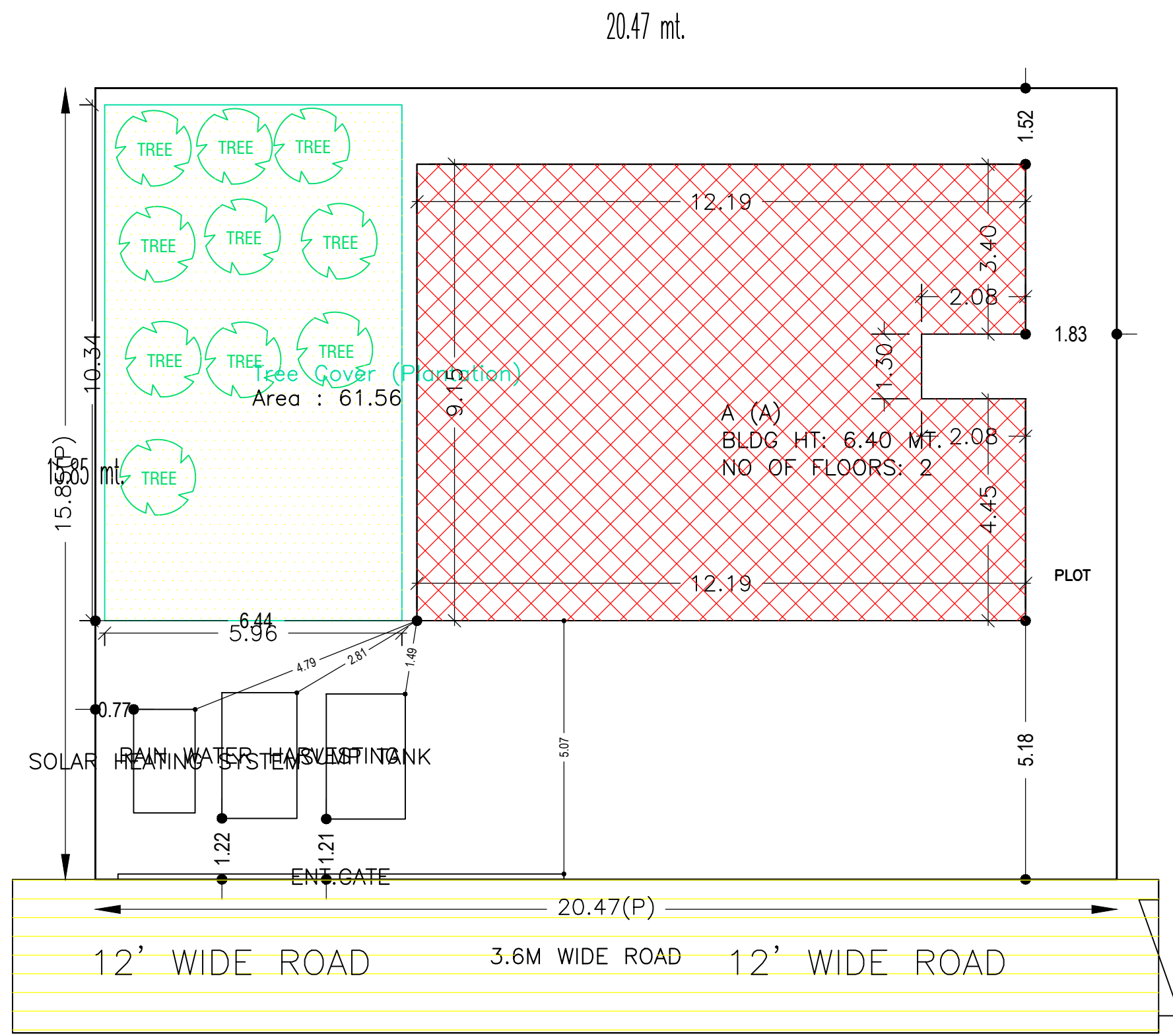

| COLOR INDEX | |
|-----------------------------|------------|
| PLOT BOUNDARY | Black |
| ABUTTING ROAD | Green |
| PROPOSED CONSTRUCTION | Red |
| COMMON PLOT | Yellow |
| ROAD WIDENING AREA | Blue |
| EXISTING (To be retained) | Orange |
| EXISTING (To be demolished) | Light Blue |

Buildingwise Floor FAR Details

| Floor Name | Building Name A (A) | | Total | |
|----------------|---------------------------------|----------------------------|---------------------------------------|-------------------------|
| | Proposed Built Up Area (Sq.mt.) | Proposed FAR Area (Sq.mt.) | Total Proposed Built Up Area (Sq.mt.) | Total FAR Area (Sq.mt.) |
| Ground Floor | 108.84 | 108.84 | 108.84 | 108.84 |
| First Floor | 108.84 | 108.84 | 108.84 | 108.84 |
| Terrace Floor | 0.00 | 0.00 | 0.00 | 0.00 |
| Total : | 217.68 | 217.68 | 217.68 | 217.68 |

| AREA STATEMENT | | VERSION NO.: 1.0.43 |
|--|---|--------------------------|
| DHANBAD MUNICIPAL CORPORATION | | VERSION DATE: 29/04/2019 |
| PROJECT DETAIL: | | |
| Region: JHARKHAND URBAN LOCAL BODIES | Plot Use: Residential | |
| District: DHANBAD | Plot SubUse: Bungalow/ Dwelling / Non Apartment | |
| Authority: DHANBAD MUNICIPAL CORPORATION | PlotNearby/ReligiousStructure: NA | |
| Inward No: DMC/BP/0355/W23/2019 | PlotSubPlot No: OLD PLOT NO. - 3329 (NEW - 4035, 4910) | |
| Application Type: General Proposal | North: Road Width - 3.6 | |
| Project Type: Building Permission | South: Road Width - 3.04 | |
| Nature of Development: New | East: Plot No. - N.K. RAJAK | |
| Location of Development Area: Old Area | West: Plot No. - RAMA SHANKAR SINGH | |

FAR & Tenement Details (Table 4c-1)

| Building | No. of Same Bldg | Total Built Up Area (Sq.mt.) | Proposed FAR Area (Sq.mt.) Resi. | Total FAR Area (Sq.mt.) | Total Consumed Additional FAR Area (Sq.mt.) | Tnmt (No.) |
|----------------------|------------------|------------------------------|----------------------------------|-------------------------|---|------------|
| A (A) | 1 | 217.68 | 217.68 | 217.68 | 217.68 | 01 |
| Grand Total : | 1 | 217.68 | 217.68 | 217.68 | 217.68 | 01 |

Building USE/SUBUSE Details

| Building Name | Building Use | Building SubUse | Building Structure |
|---------------|--------------|----------------------------|--------------------|
| A (A) | Residential | Residential Bldg/Apartment | Non-Highrise |

UnitBUA Table for Building :A (A)

| FLOOR | Name | UnitBUA Type | UnitBUA Area | Carpet Area | No. of Rooms | No. of Tenement |
|-------------------|---------|--------------|---------------|---------------|--------------|-----------------|
| GROUND FLOOR PLAN | SPLIT 1 | FLAT | 217.67 | 217.57 | 11 | 1 |
| FIRST FLOOR PLAN | SPLIT 1 | FLAT | 0.00 | 0.00 | 11 | 0 |
| Total: | - | - | 217.67 | 217.57 | 22 | 1 |

SCHEDULE OF DOOR:

| BUILDING NAME | NAME | LENGTH | HEIGHT | NOS |
|---------------|------|--------|--------|-----|
| A (A) | D | 0.66 | 2.10 | 04 |
| A (A) | D | 0.90 | 2.10 | 16 |

SCHEDULE OF WINDOW/VENTILATION:

| BUILDING NAME | NAME | LENGTH | HEIGHT | NOS |
|---------------|------|--------|--------|-----|
| A (A) | W | 1.17 | 1.20 | 06 |
| A (A) | W | 1.30 | 1.20 | 02 |
| A (A) | W | 1.80 | 1.20 | 12 |
| A (A) | W | 2.36 | 1.20 | 02 |

Building :A (A)

| Floor Name | Total Built Up Area (Sq.mt.) | Proposed FAR Area (Sq.mt.) Resi. | Total FAR Area (Sq.mt.) | Total Consumed Additional FAR Area (Sq.mt.) | Tnmt (No.) |
|---------------------------------------|------------------------------|----------------------------------|-------------------------|---|------------|
| Ground Floor | 108.84 | 108.84 | 108.84 | 108.84 | 01 |
| First Floor | 108.84 | 108.84 | 108.84 | 108.84 | 00 |
| Terrace Floor | 0.00 | 0.00 | 0.00 | 0.00 | 00 |
| Total : | 217.68 | 217.68 | 217.68 | 217.68 | 01 |
| Total Number of Same Buildings | 1 | | | | |

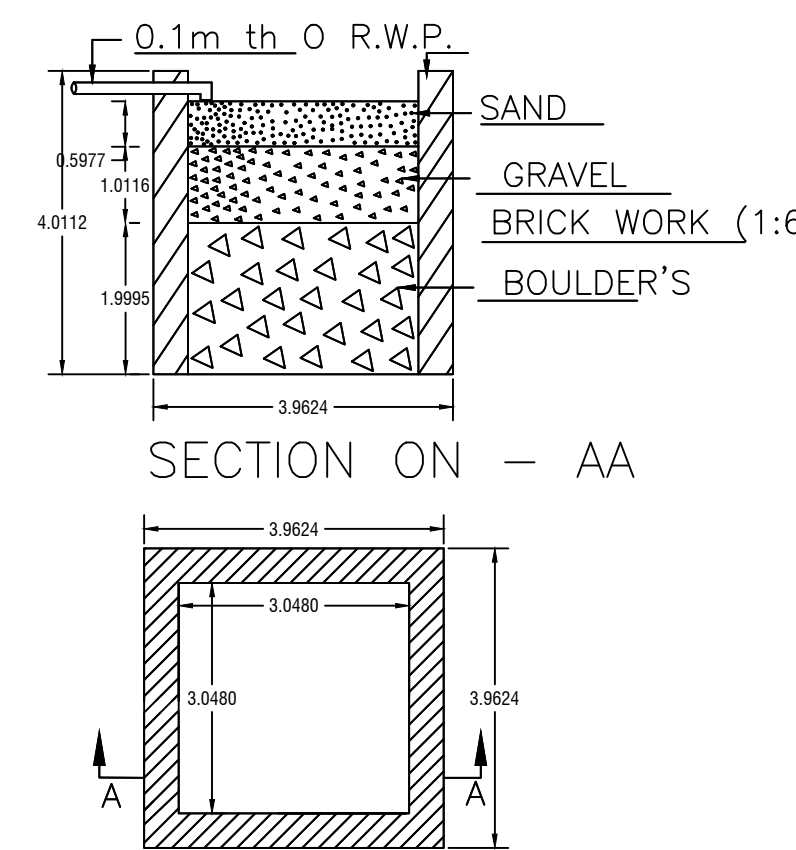
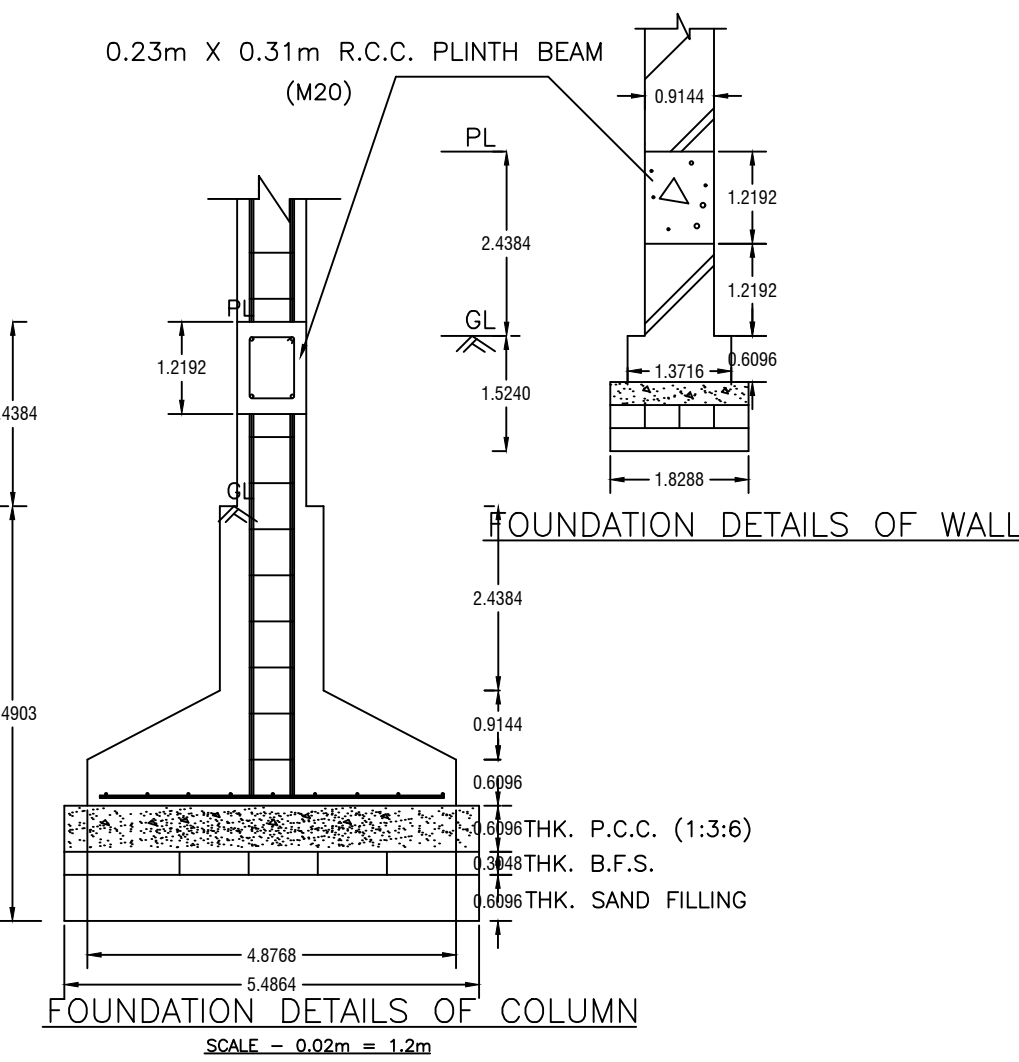

DETAIL'S OF WATER HARVESTING

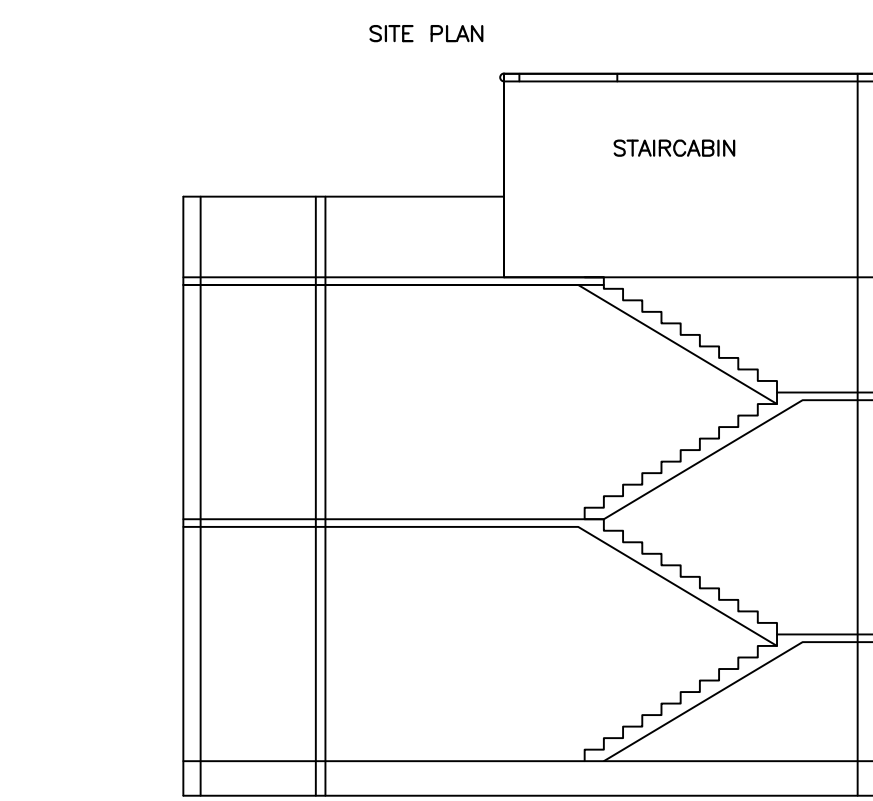

SECTION ON Y-Y

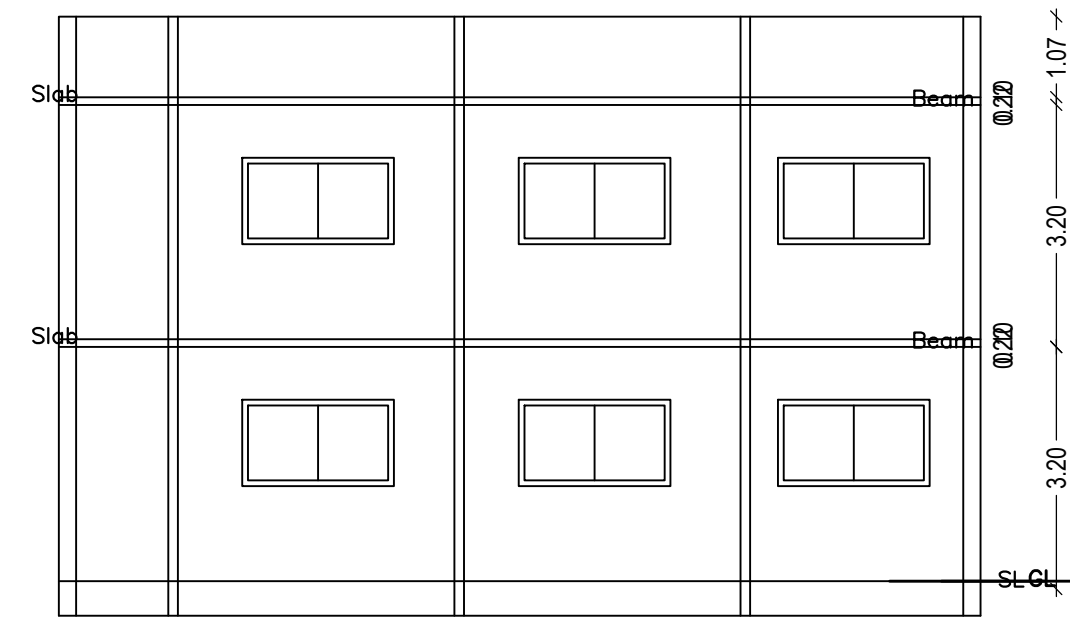

SECTION ON X-X

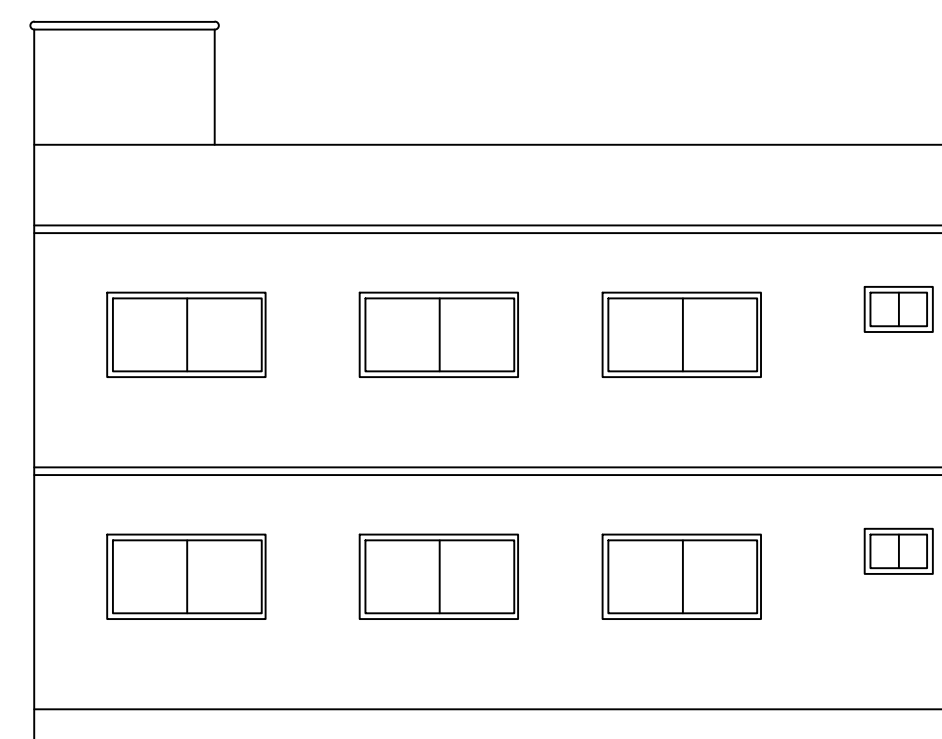

FRONT ELEVATION

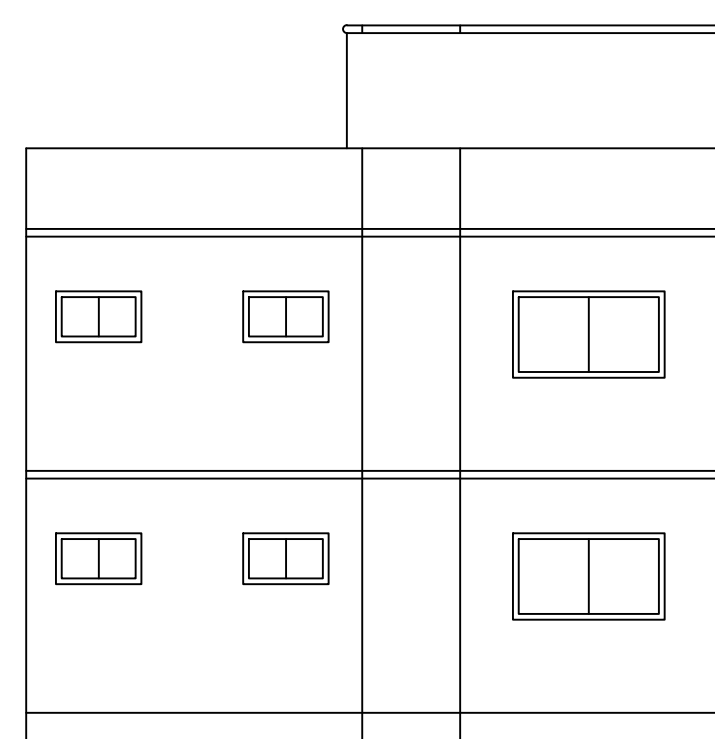

RIGHT SIDE ELEVATION