

SITE PLAN
SCALE:- 1"=8'0"

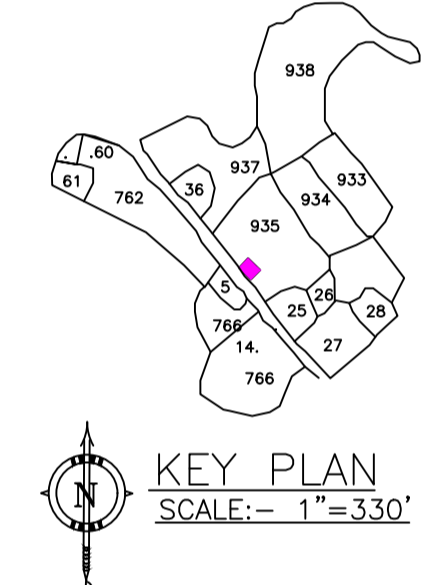

KEY PLAN
SCALE:- 1"=3'30"

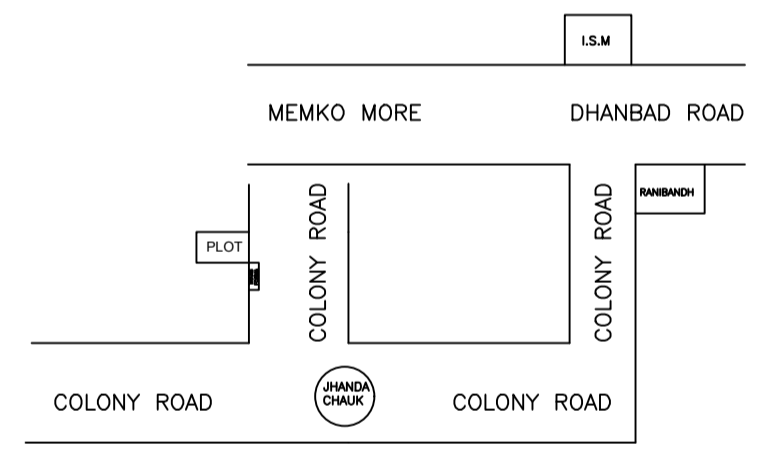

LOCATION PLAN
NOT FOR SCALE

SCHEDULE OF DOOR:

BUILDING NAME	NAME	LENGTH	HEIGHT	NOS
A (RUBI DEVI AND KANCHAN SINGH)	D	0.76	2.10	01
A (RUBI DEVI AND KANCHAN SINGH)	D	0.91	2.10	02
A (RUBI DEVI AND KANCHAN SINGH)	D	1.02	2.10	04
A (RUBI DEVI AND KANCHAN SINGH)	D	1.07	2.10	01

SCHEDULE OF WINDOW/VENTILATION:

BUILDING NAME	NAME	LENGTH	HEIGHT	NOS
A (RUBI DEVI AND KANCHAN SINGH)	W	0.77	1.20	01
A (RUBI DEVI AND KANCHAN SINGH)	W	1.36	1.20	02
A (RUBI DEVI AND KANCHAN SINGH)	W	1.56	1.20	09

UnitBUA Table for Building :A (RUBI DEVI AND KANCHAN SINGH)

FLOOR	Name	UnitBUA Type	UnitBUA Area	Carpet Area	No. of Rooms	No. of Tenement
FIRST FLOOR PLAN	SPLIT 1	FLAT	0.00	0.00	5	0
GROUND FLOOR PLAN	SPLIT 1	FLAT	112.25	112.05	4	1
Total:	-	-	112.25	112.05	9	1

FAR & Tenement Details (Table 4c-1)

Building	No. of Same Bldg	Total Built Up Area (Sq.mt.)	Proposed FAR Area (Sq.mt.)	Total FAR Area (Sq.mt.)	Total Consumed Additional FAR Area (Sq.mt.)	Tnmt (No.)
A (RUBI DEVI AND KANCHAN SINGH)	1	112.24	112.24	112.24	112.24	01
Grand Total :	1	112.24	112.24	112.24	112.24	01

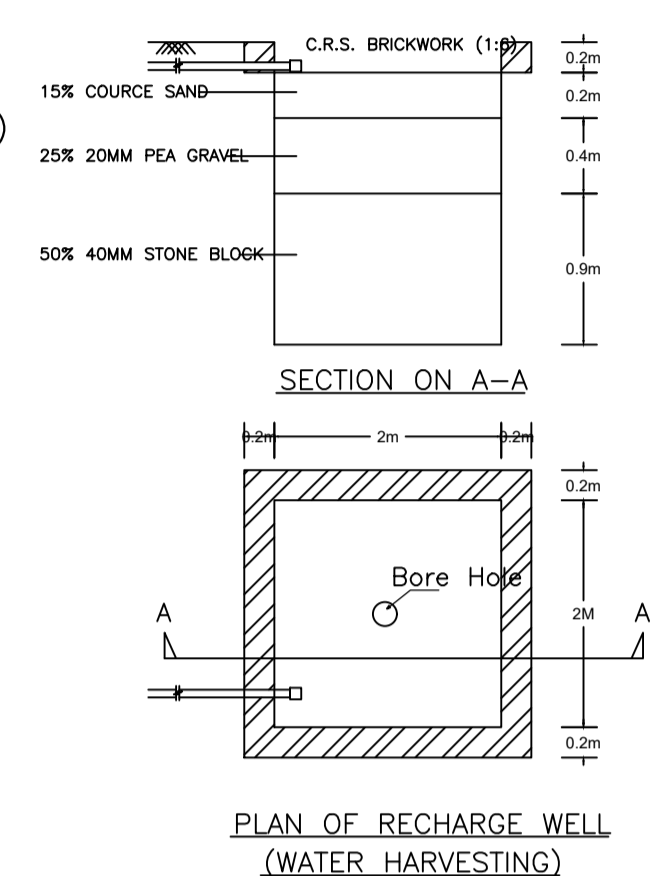

PLAN OF RECHARGE WELL (WATER HARVESTING)

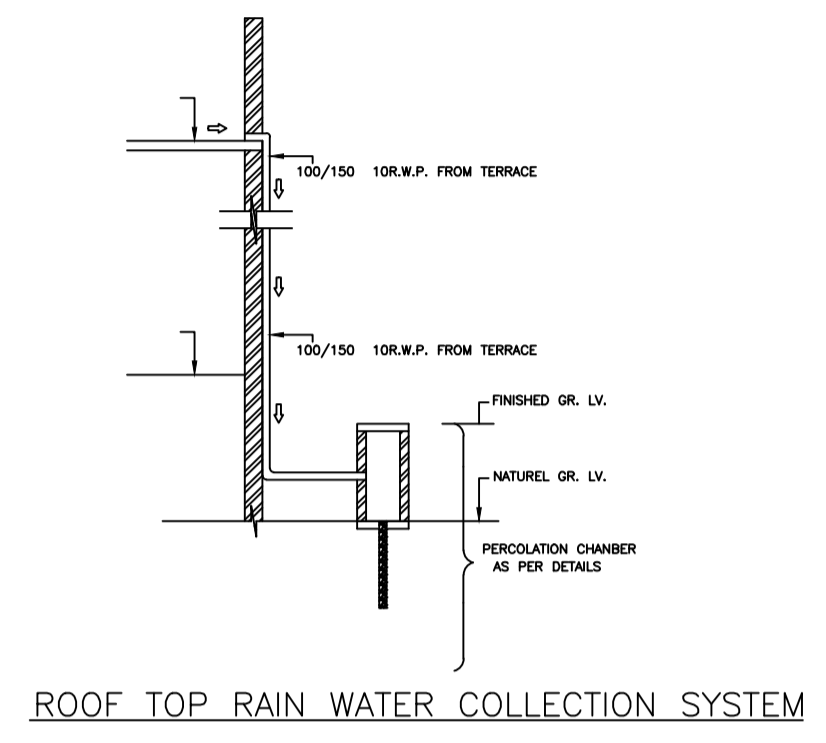

ROOF TOP RAIN WATER COLLECTION SYSTEM

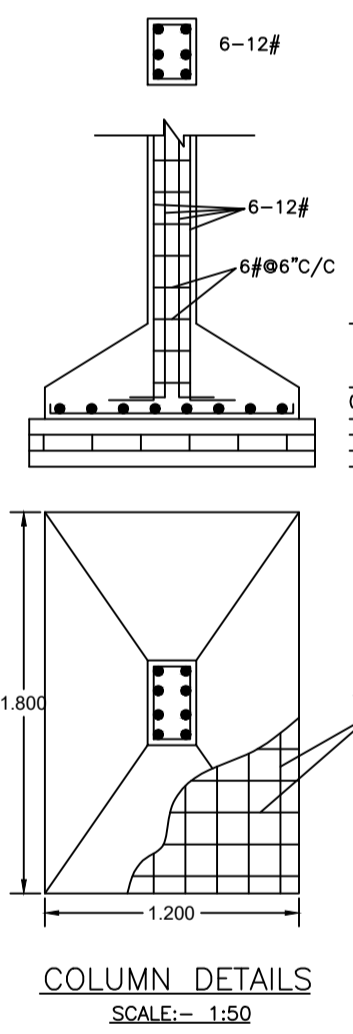

COLUMN DETAILS
SCALE:- 1:50

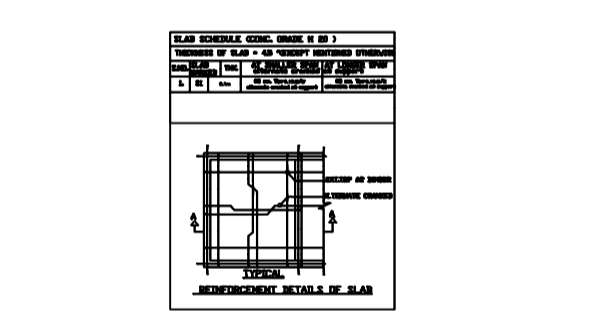
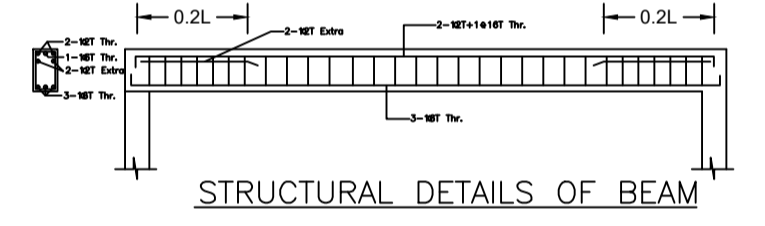

TYP. DETAIL OF STAIR

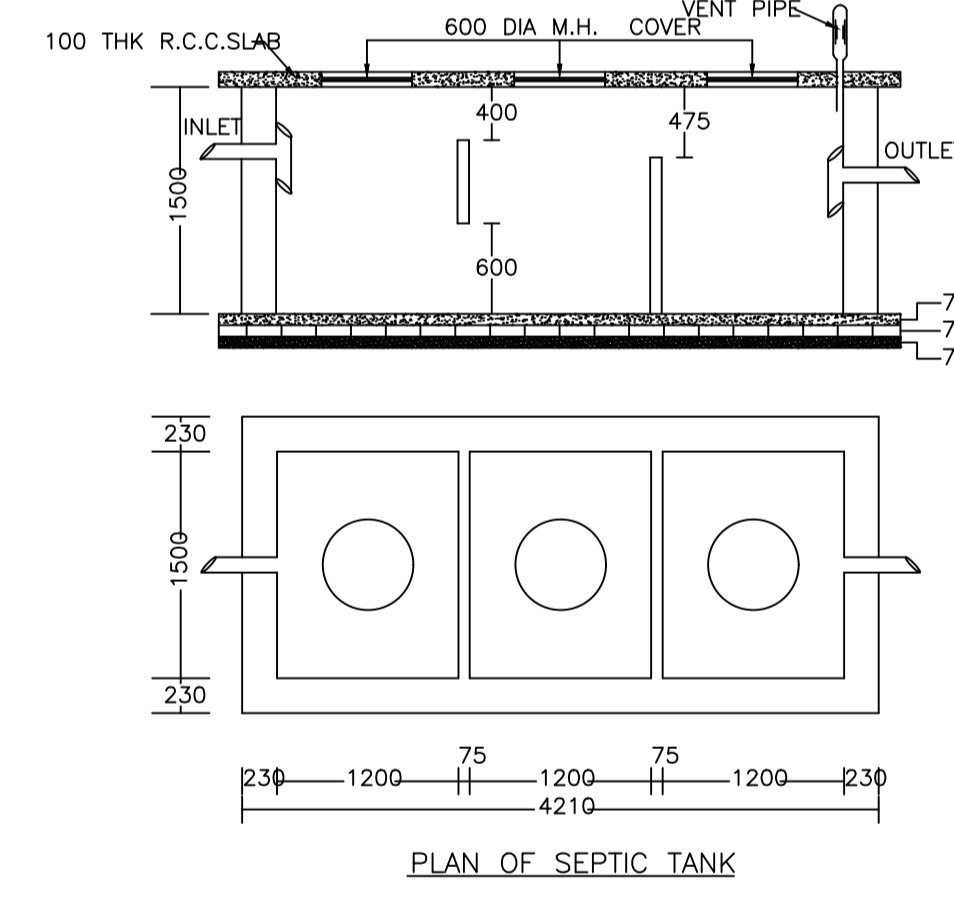

PLAN OF SEPTIC TANK

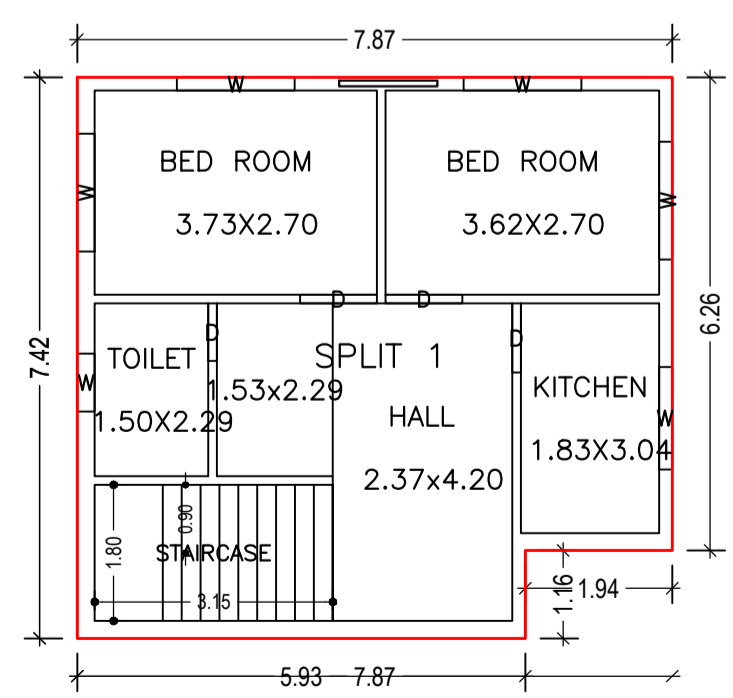

FIRST FLOOR PLAN (Proposed)
(SCALE 1:100)

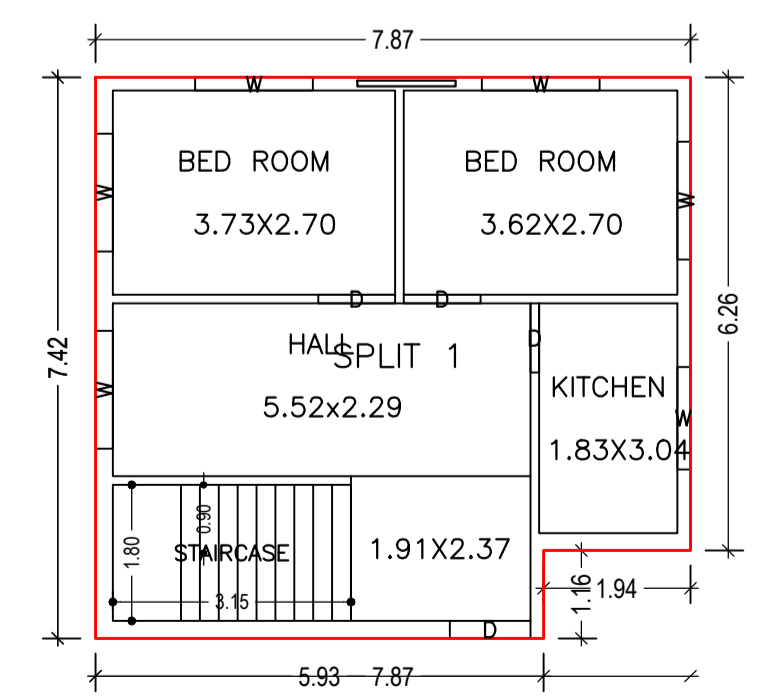

GROUND FLOOR PLAN (Proposed)
(SCALE 1:100)

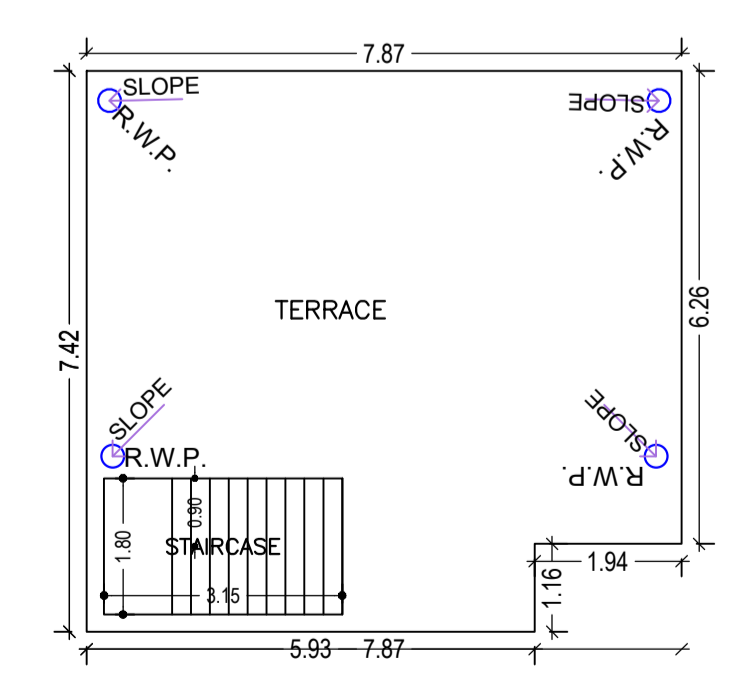

TERRACE FLOOR PLAN (SCALE 1:100)

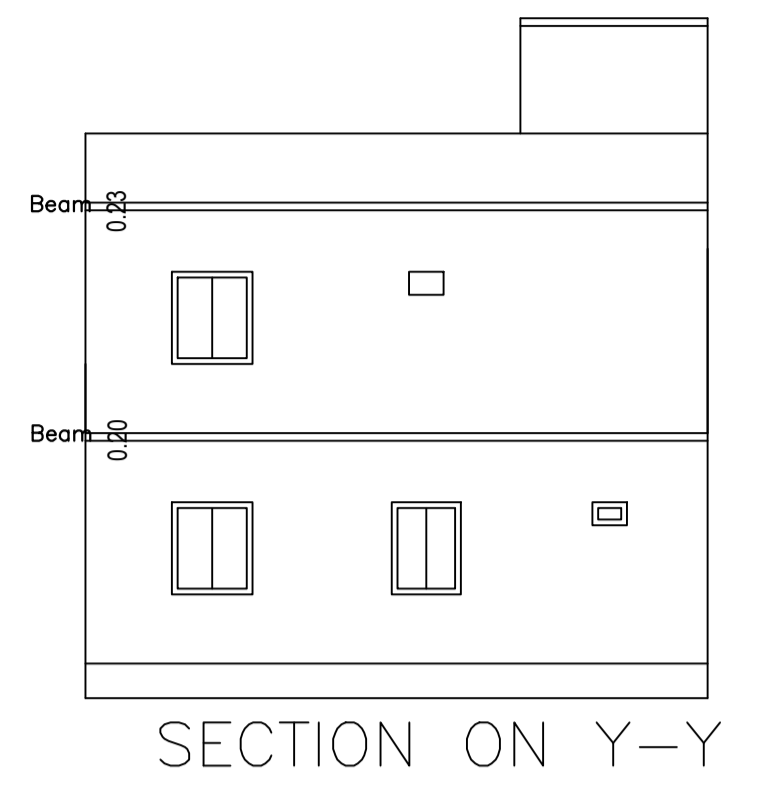

SECTION ON Y-Y

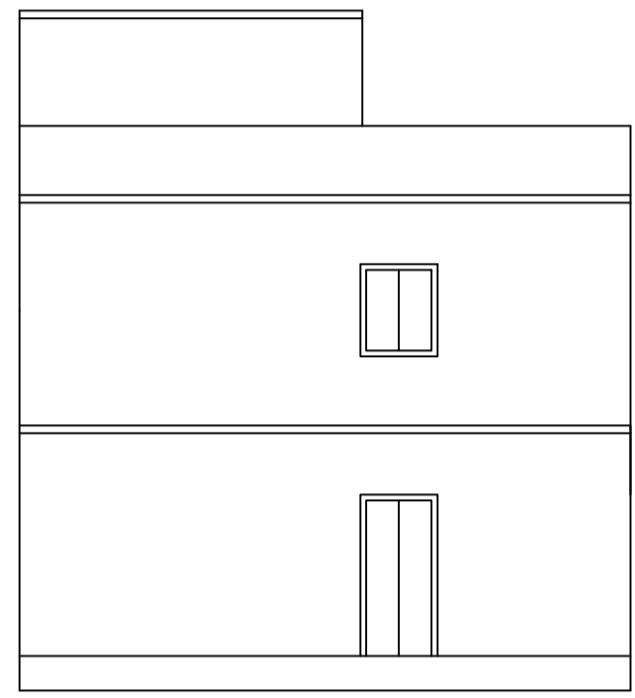

FRONT ELEVATION

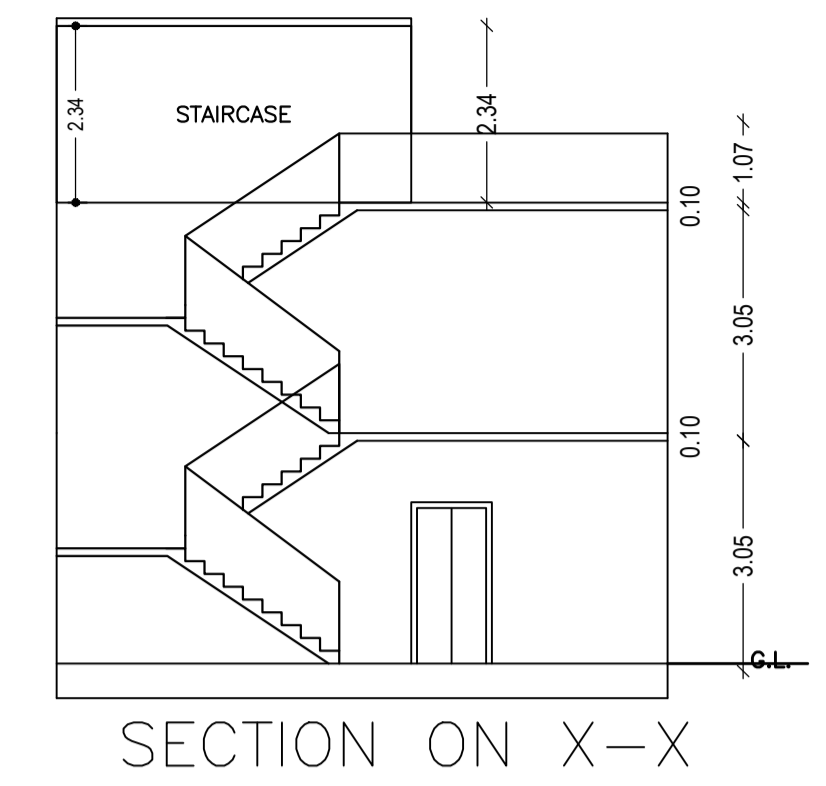

SECTION ON X-X

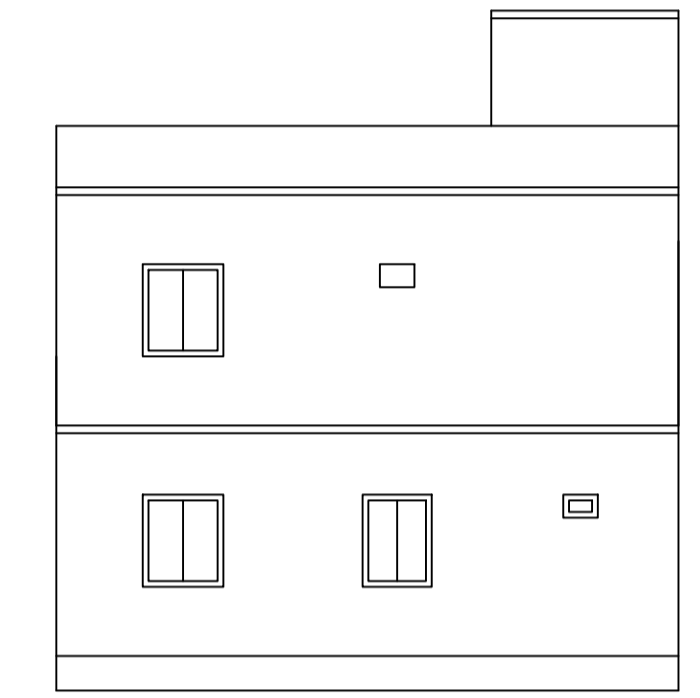

LEFT ELEVATION

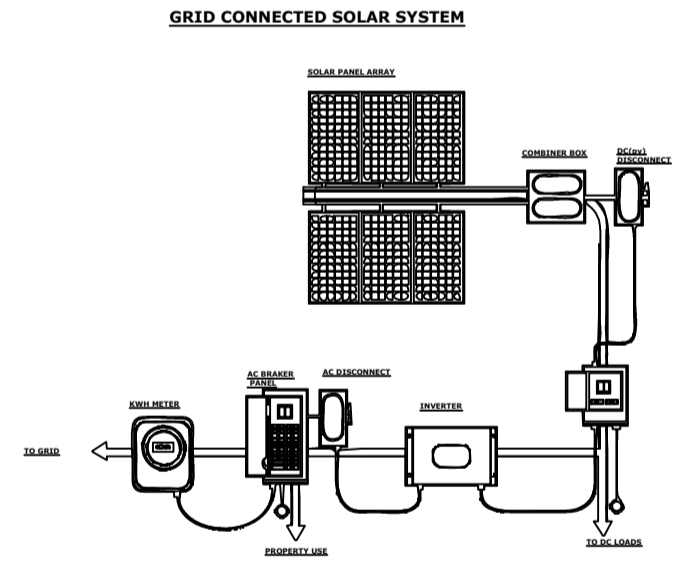

GRID CONNECTED SOLAR SYSTEM

Proposal Basic Information

Proposal File No.	DMC/BP/0375/W21/2019
Owner Name	SMT RUBI DEVI, SMT KANCHAN SINGH
Khata No.	162
Plot No.	935
Village Name	Dhaiya
Use	Residential
SubUse	Bungalow/ Dwelling / Non Apartment

AREA STATEMENT
DHANBAD MUNICIPAL CORPORATION

AREA OF PLOT (Minimum)	(A)	SQ.MT.
NET AREA OF PLOT (Gross Plot Area - Deduction from Gross Plot area)	(A-Deductions)	106.80
Deduction for Balance Plot Area (from Gross Plot Area)		
Common Plot		22.46
BALANCE AREA OF PLOT (Net Plot Area - Recreational/Amenity space)	(A-Deductions)	84.34
PLOT AREA FOR COVERAGE (Net Plot Area)	(A-Deductions)	106.80
Plot Area for FAR (Net Plot Area + Road Widening Area)	(A-Deductions)	106.80
COVERAGE CHECK		
Permissible Coverage area (70.00 %)		74.76
Proposed Coverage Area (52.55 %)		56.12
Total Prop. Coverage Area (52.55 %)		56.12
Balance coverage area (17.45 %)		18.64
FAR CHECK		
Perm. FAR Area (1.50)		160.20
Total Perm. FAR area		160.20
Residential FAR		112.25
Proposed FAR Area		112.25
Total Proposed FAR Area		112.25
Consumed FAR (Factor)		1.05
Balance FAR Area		47.95
BUILT UP AREA CHECK		
Total Proposed BuiltUp Area		112.24
ARCHITECT (Regd)	RAJEEV RANJAN SINGH	
ENGINEER (Regd)		
SUPERVISOR (Regd)		
OWNER (Regd)	SMT RUBI DEVI, SMT KANCHAN SINGH	
DEVELOPMENT AUTHORITY LOCAL BODY		

COLOR INDEX

PLOT BOUNDARY	Black
ABUTTING ROAD	Red
PROPOSED CONSTRUCTION	Green
COMMON PLOT	Yellow
ROAD WIDENING AREA	Blue
EXISTING (To be retained)	Light Blue
EXISTING (To be demolished)	Dark Blue

Buildingwise Floor FAR Details

Floor Name	Building Name		Total	
	A (RUBI DEVI AND KANCHAN SINGH) Proposed Built Up Area (Sq.mt.)	Proposed FAR Area (Sq.mt.)	Total Proposed Built Up Area (Sq.mt.)	Total FAR Area (Sq.mt.)
Ground Floor	56.12	56.12	56.12	56.12
First Floor	56.12	56.12	56.12	56.12
Terrace Floor	0.00	0.00	0.00	0.00
Total :	112.24	112.24	112.24	112.24

Building USE/SUBUSE Details

Building Name	Building Use	Building SubUse	Building Structure
A (RUBI DEVI AND KANCHAN SINGH)	Residential	Residential Bldg/Apartment	Non-Highrise

Building :A (RUBI DEVI AND KANCHAN SINGH)

Floor Name	Total Built Up Area (Sq.mt.)	Proposed FAR Area (Sq.mt.)	Total FAR Area (Sq.mt.)	Total Consumed Additional FAR Area (Sq.mt.)	Tnmt (No.)
Ground Floor	56.12	56.12	56.12	56.12	01
First Floor	56.12	56.12	56.12	56.12	00
Terrace Floor	0.00	0.00	0.00	0.00	00
Total :	112.24	112.24	112.24	112.24	01

LTP NAME AND SIGNATURE	STRUCTURAL ENG'S NAME AND SIGNATURE	BUILDER NAME AND SIGNATURE	DIGITAL SIGNATURE
RAJEEV RANJAN SINGH DMC/ENG/0032/2017			