

Proposal Basic Information

Proposal File No.	DMC/BP/0063/W23/2019
Owner Name	Sri shankar sah
Khata No	25 / 31
Plot No	120
Village Name	Kolakusma
Use	Residential
SubUse	Bungalow/ Dwelling / Non Apartment

AREA STATEMENT DHANBAD MUNICIPAL CORPORATION	VERSION NO.: 1.0.35 VERSION DATE: 13/03/2019
PROJECT DETAIL:	
Region: JHARKHAND URBAN LOCAL BODIES	Plot Use: Residential
District: DHANBAD	Plot SubUse: Bungalow/ Dwelling / Non Apartment
Authority: DHANBAD MUNICIPAL CORPORATION	PlotNearbyReligiousStructure: NA
Inward No: DMC/BP/0063/W23/2019	PlotSubPlot No: 120
Application Type: General Proposal	North: Plot No. - saruv kumar suman
Project Type: Building Permission	South: Plot No. - 30
Nature of Development: New	East: Plot No. - 20.21
Location of Development Area: Old Area	West: Road Width - 6.1
AREA DETAILS:	
AREA OF PLOT (Minimum)	(A) 111.50 SQ.MT.
NET AREA OF PLOT(Gross Plot Area - Deduction from Gross Plot area)	(A-Deductions) 111.50
Deduction for Balance Plot Area (from Gross Plot Area)	
Common Plot	8.37
Total	8.37
BALANCE AREA OF PLOT(Net Plot Area - Recreational/Amenity space)	(A-Deductions) 103.12
PLOT AREA FOR COVERAGE(Net Plot Area)	(A-Deductions) 111.50
Plot Area for FAR (Net Plot Area + Road Widening Area)	(A-Deductions) 111.50
COVERAGE CHECK	
Permissible Coverage area ( 70.00 % )	78.05
Proposed Coverage Area ( 53.60 % )	59.76
Total Prop. Coverage Area ( 53.6 % )	59.76
Balance coverage area ( 16.40 % )	18.29
FAR CHECK	
Perm. FAR Area ( 2.50 )	278.75
Total Perm. FAR area	278.75
Residential FAR	112.78
Proposed FAR Area	112.78
Total Proposed FAR Area	112.78
Consumed FAR (Factor)	1.01
Balance FAR Area	165.97
BUILT UP AREA CHECK	
Total Proposed BuiltUp Area	117.75
ARCHITECT (Regd)	KUMARI RINKU RANI
ENGINEER (Regd)	
SUPERVISOR (Regd)	
OWNER (Regd)	Sri shankar sah
DEVELOPMENT AUTHORITY LOCAL BODY	

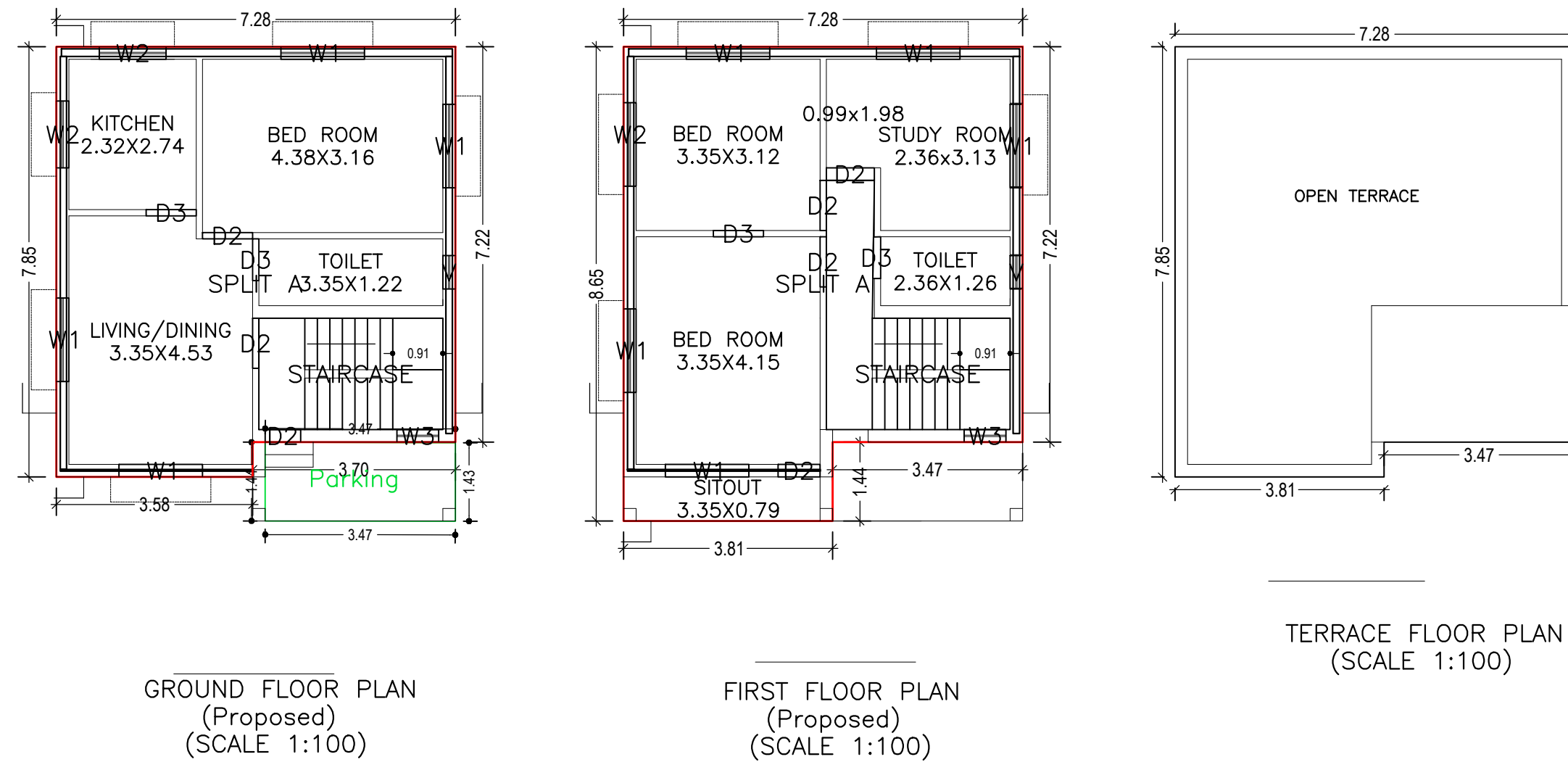
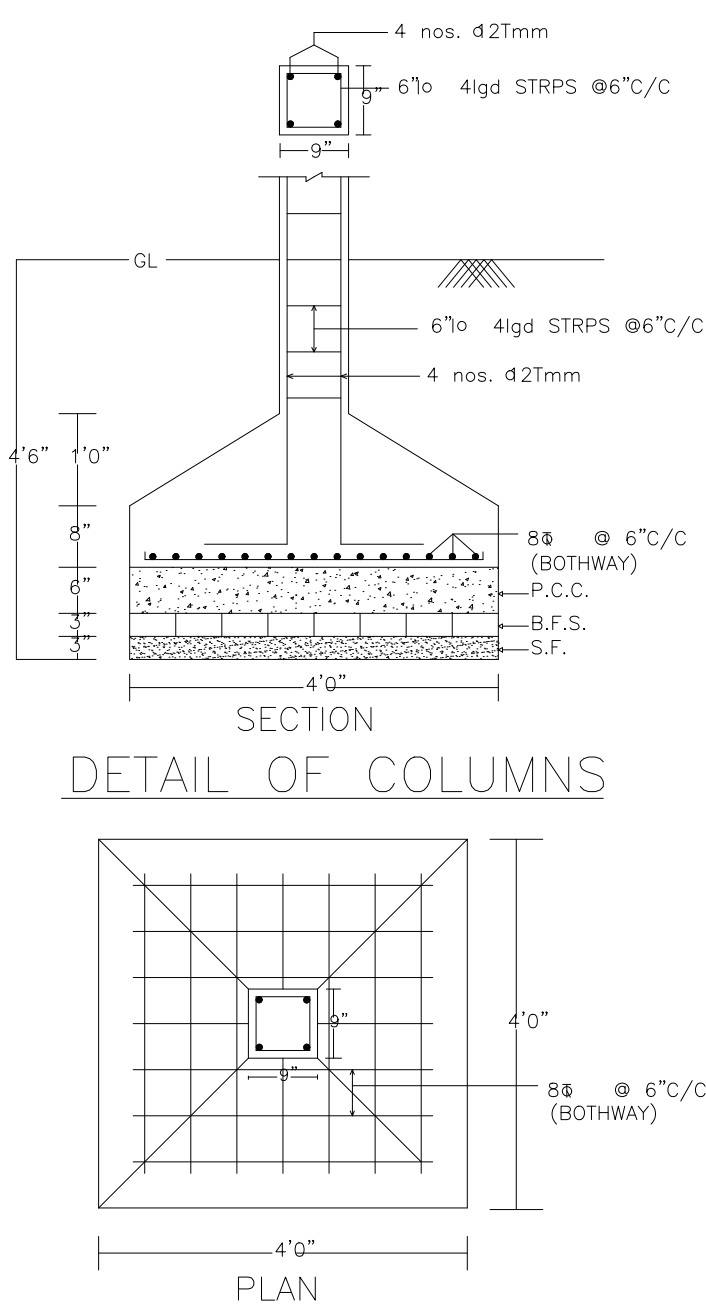
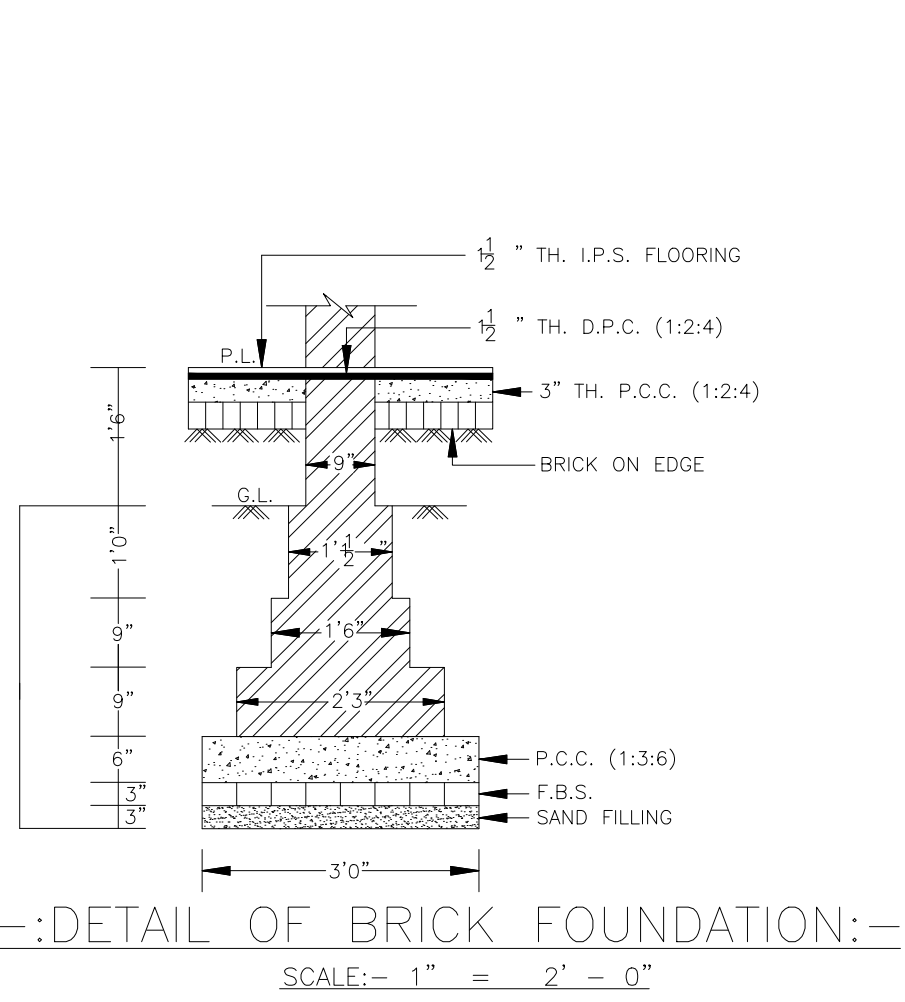
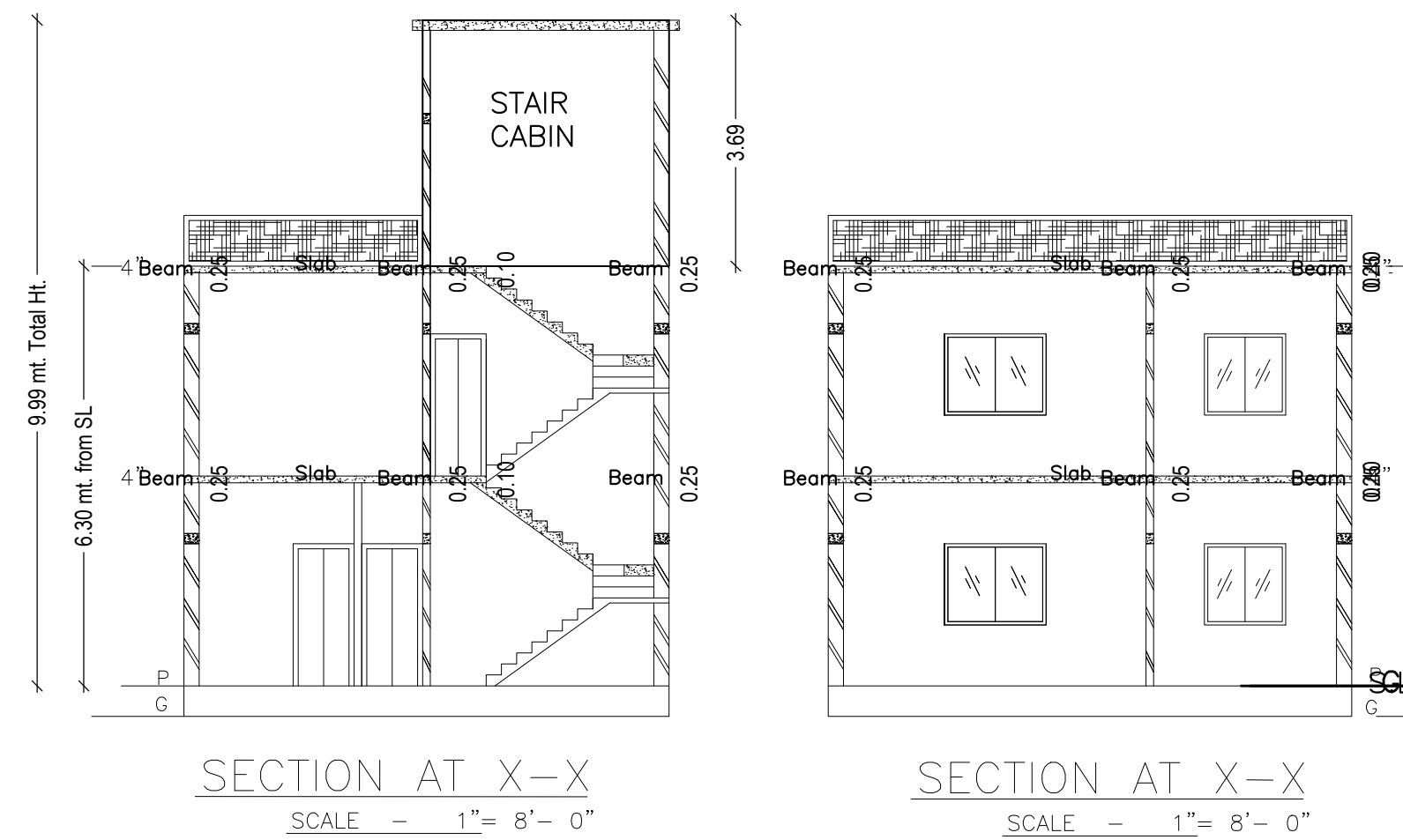
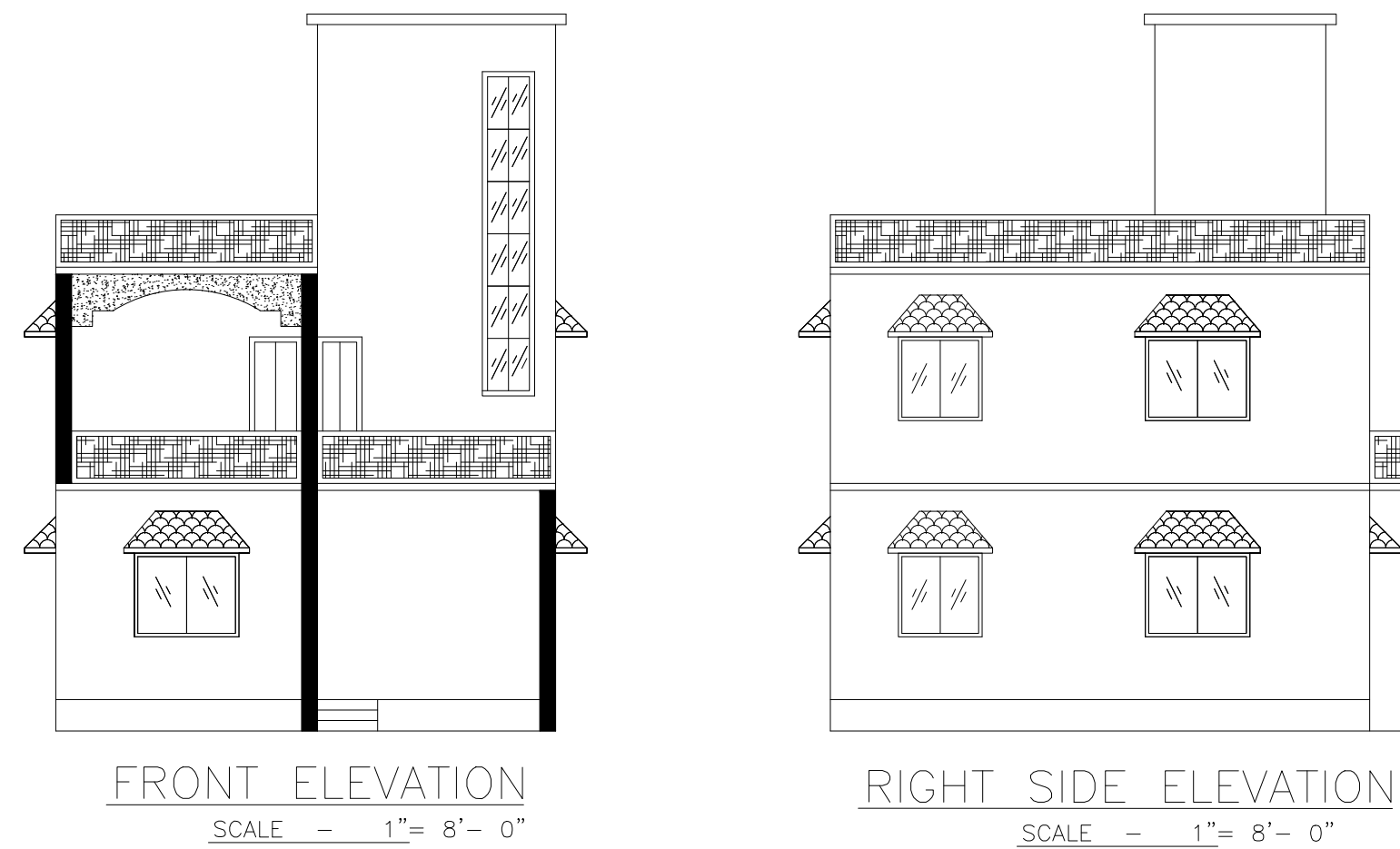
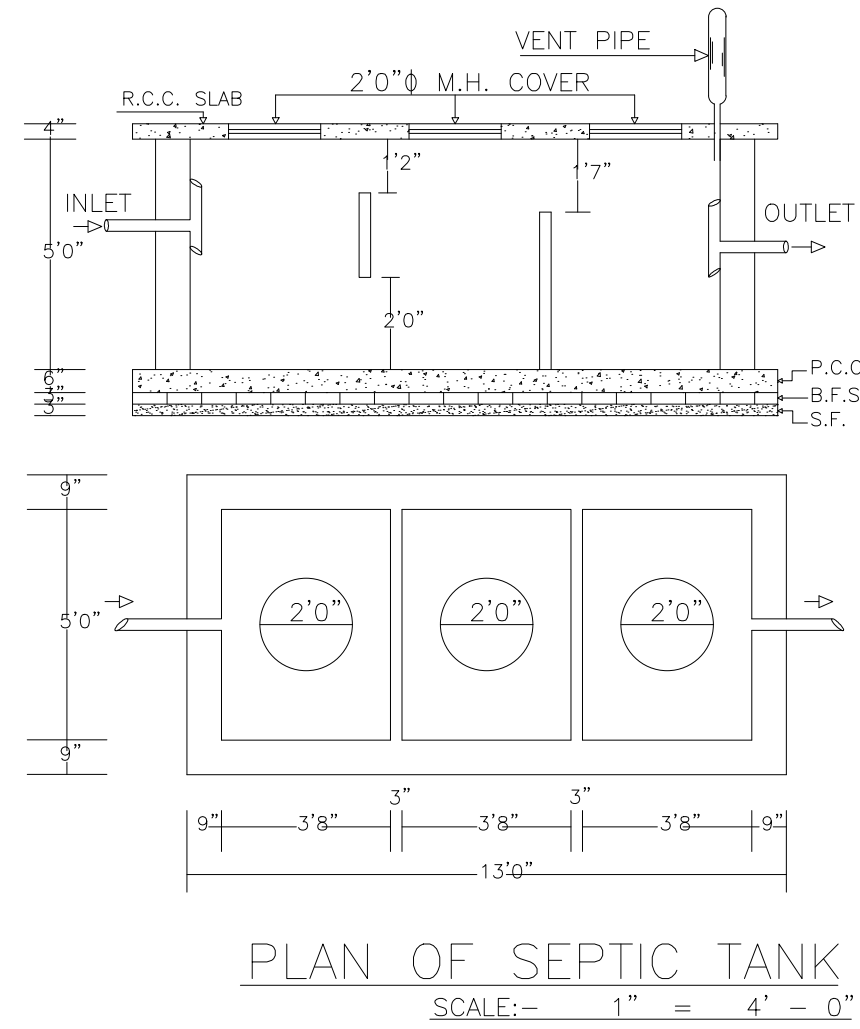
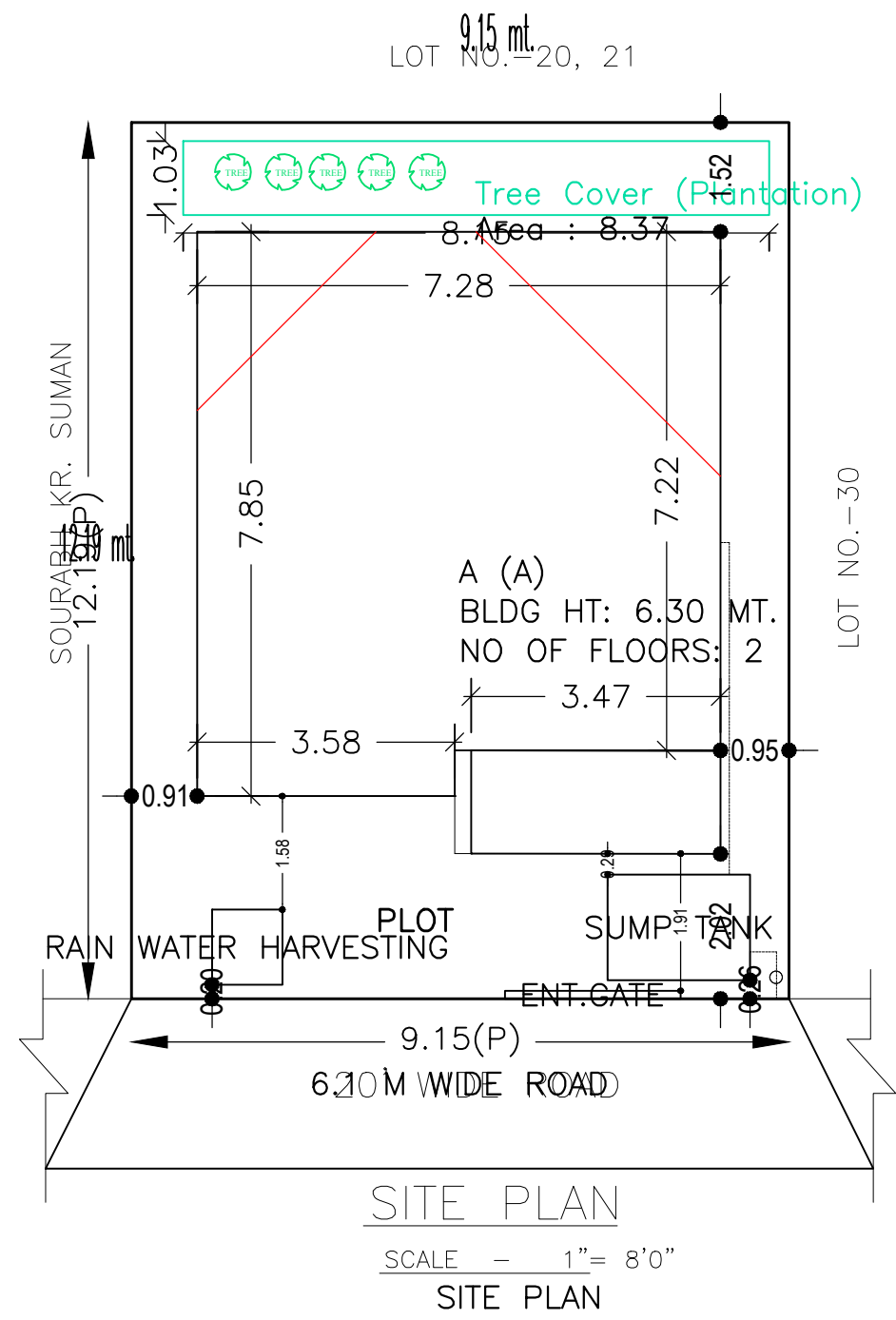

Building USE/SUBUSE Details

Building Name	Building Use	Building SubUse	Building Structure
A (A)	Residential	Bungalow/ Dwelling / Non Apartment	Non-Highrise

UnitBUA Table for Building :A (A)

FLOOR	Name	UnitBUA Type	UnitBUA Area	Carpet Area	No. of Rooms	No. of Tenement
GROUND FLOOR PLAN	SPLIT A	FLAT	112.78	107.22	4	1
FIRST FLOOR PLAN	SPLIT A	FLAT	0.00	0.00	5	0
Total:	-	-	112.78	107.22	9	1

Building :A (A)

Floor Name	Total Built Up Area (Sq.mt.)	Deductions (Area in Sq.mt.)	Proposed FAR Area (Sq.mt.)	Total FAR Area (Sq.mt.)	Total Consumed Additional FAR Area (Sq.mt.)	Tnmt (No.)
Ground Floor	59.76	4.97	54.79	54.79	54.79	01
First Floor	57.99	0.00	57.99	57.99	57.99	00
Terrace Floor	0.00	0.00	0.00	0.00	0.00	00
Total:	117.75	4.97	112.78	112.78	112.78	01
Total Number of Same Buildings:	1					
Total:	117.75	4.97	112.78	112.78	112.78	01

FAR & Tenement Details (Table 4c-1)

Building	No. of Same Bldg	Total Built Up Area (Sq.mt.)	Deductions (Area in Sq.mt.)	Proposed FAR Area (Sq.mt.)	Total FAR Area (Sq.mt.)	Total Consumed Additional FAR Area (Sq.mt.)	Tnmt (No.)
A (A)	1	117.75	4.97	112.78	112.78	112.78	01
Grand Total:	1	117.75	4.97	112.78	112.78	112.78	01

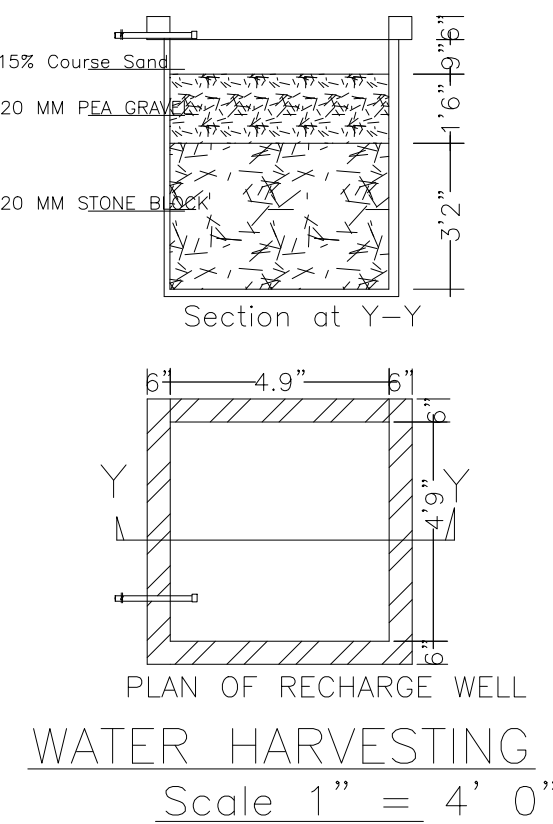
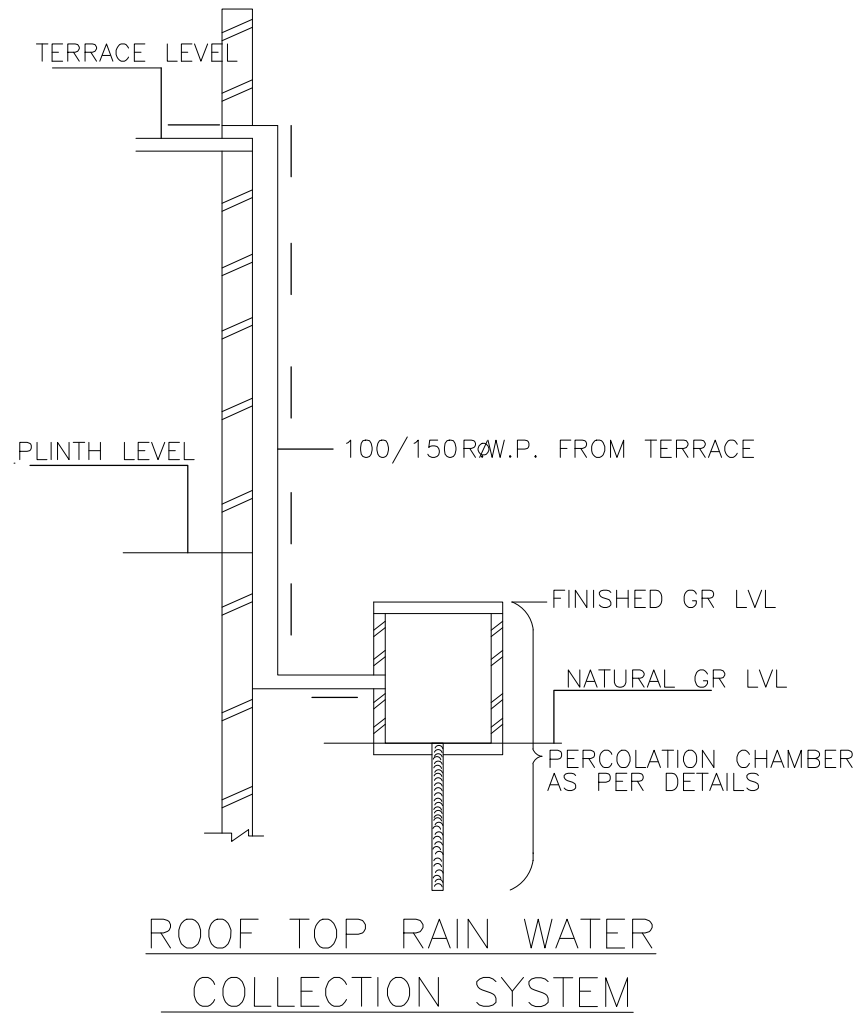

**COLOR INDEX**

PLOT BOUNDARY	Black
ABUTTING ROAD	Red
PROPOSED CONSTRUCTION	Green
COMMON PLOT	Yellow
ROAD WIDENING AREA	Blue
EXISTING (To be retained)	Grey
EXISTING (To be demolished)	White

Buildingwise Floor FAR Details

Floor Name	Building Name A (A)		Total	
	Proposed Built Up Area (Sq.mt.)	Proposed FAR Area (Sq.mt.)	Total Proposed Built Up Area (Sq.mt.)	Total FAR Area (Sq.mt.)
Ground Floor	59.76	54.79	59.76	54.79
First Floor	57.99	57.99	57.99	57.99
Terrace Floor	0.00	0.00	0.00	0.00
Total:	117.75	112.78	117.75	112.78

SCHEDULE OF DOOR:

BUILDING NAME	NAME	LENGTH	HEIGHT	NOS
A (A)	D3	0.76	2.10	02
A (A)	D2	0.76	2.10	01
A (A)	D2	0.88	2.10	01
A (A)	D3	0.91	2.10	02
A (A)	D2	0.91	2.10	04

SCHEDULE OF WINDOW/VENTILATION:

BUILDING NAME	NAME	LENGTH	HEIGHT	NOS
A (A)	V	0.61	1.20	02
A (A)	W3	0.76	1.20	02
A (A)	W2	1.22	1.20	02
A (A)	W1	1.52	1.20	09
A (A)	W2	1.52	1.20	01

LTP NAME AND SIGNATURE KUMARI RINKU RANI DMC/ENG/0016/2016	STRUCTURAL ENG'S NAME AND SIGNATURE	BUILDER NAME AND SIGNATURE	DIGITAL SIGNATURE
--	-------------------------------------	----------------------------	-------------------

Proposal Basic Information	
Proposal File No.	DMC/BP/0063/W23/2019
Owner Name	Sri shankar sah
Khata No	25 / 31
Plot No	120
Village Name	Kolakusma
Use	Residential
SubUse	Bungalow/ Dwelling / Non Apartment

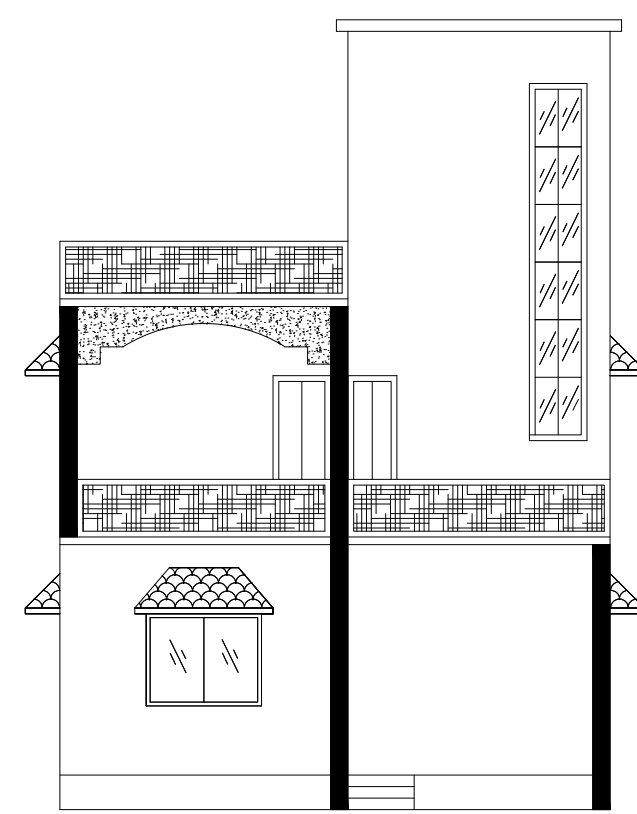

FRONT ELEVATION  
SCALE - 1" = 8' - 0"

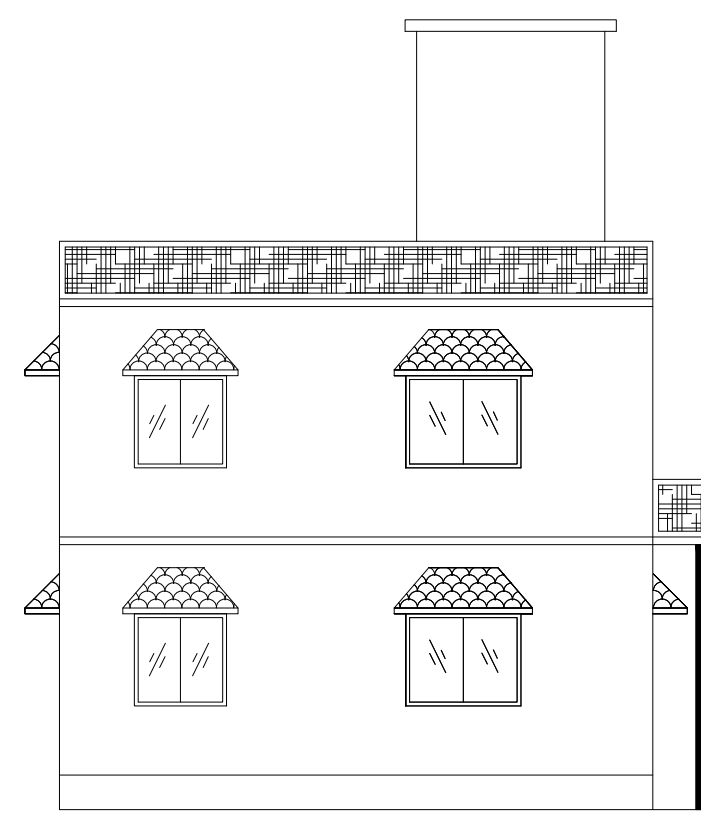

RIGHT SIDE ELEVATION  
SCALE - 1" = 8' - 0"

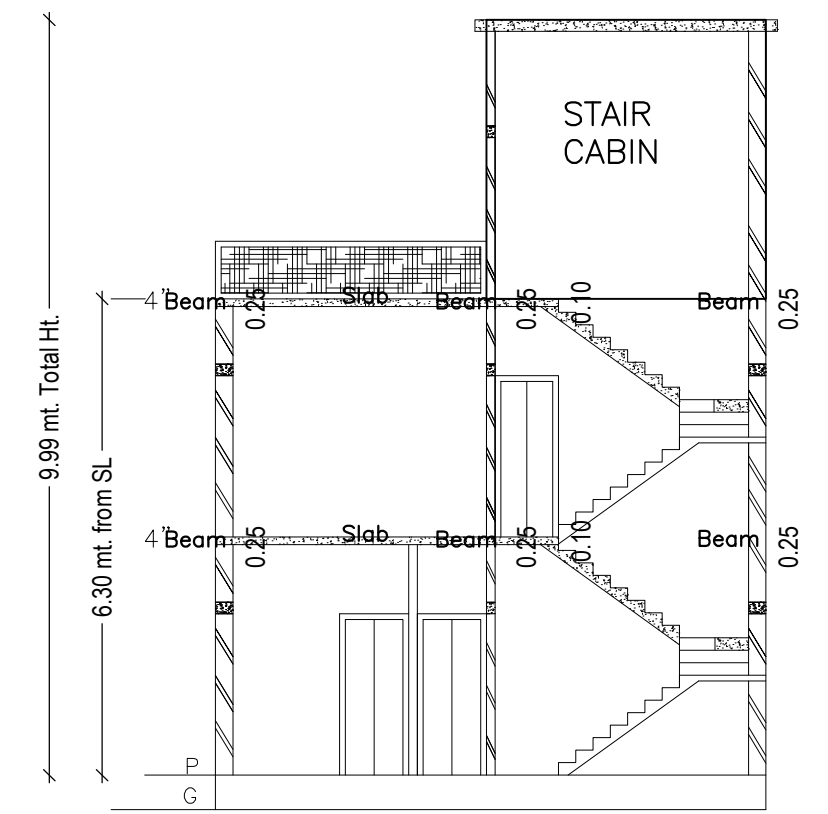

SECTION AT X-X  
SCALE - 1" = 8' - 0"

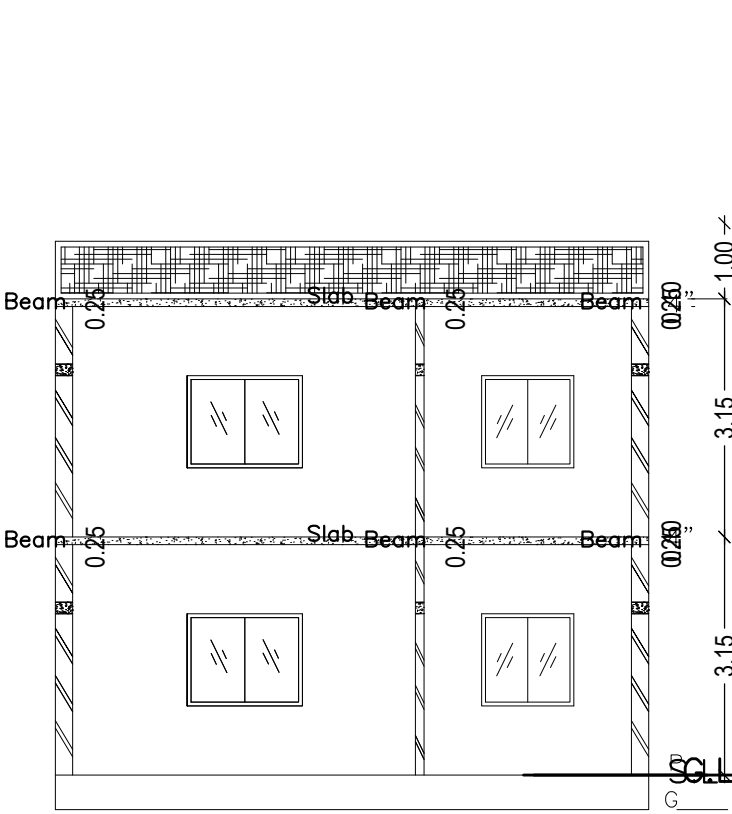

SECTION AT X-X  
SCALE - 1" = 8' - 0"

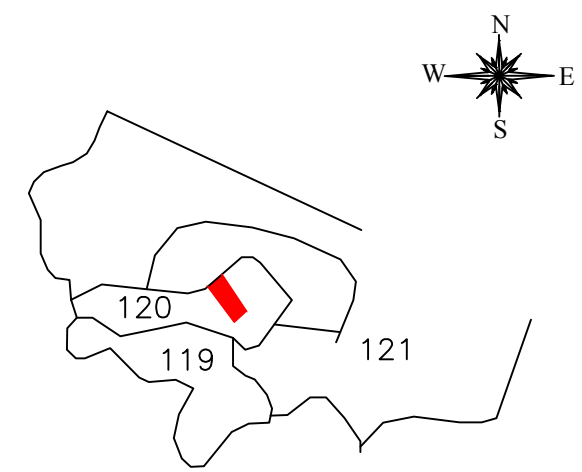

KEY PLAN

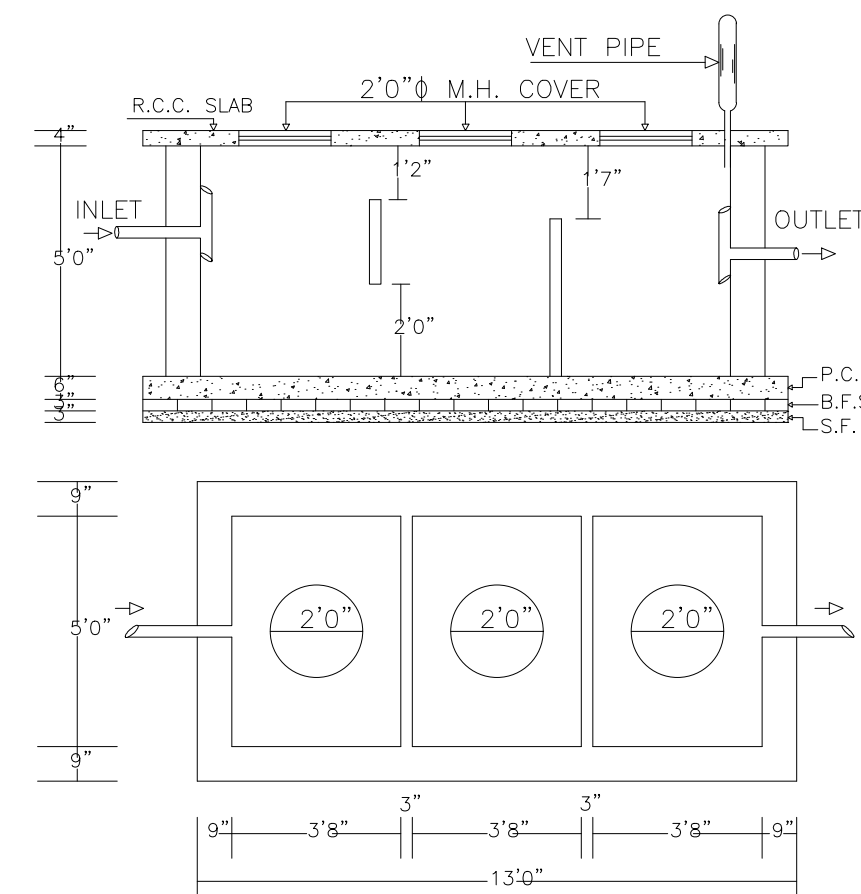

PLAN OF SEPTIC TANK  
SCALE:- 1" = 4' - 0"

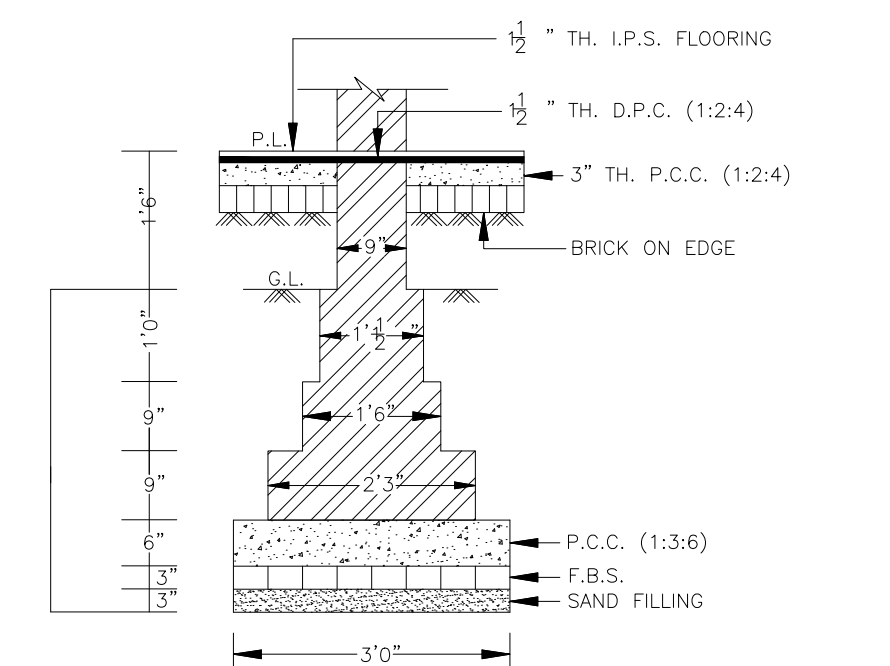

:-:DETAIL OF BRICK FOUNDATION:-  
SCALE:- 1" = 2' - 0"

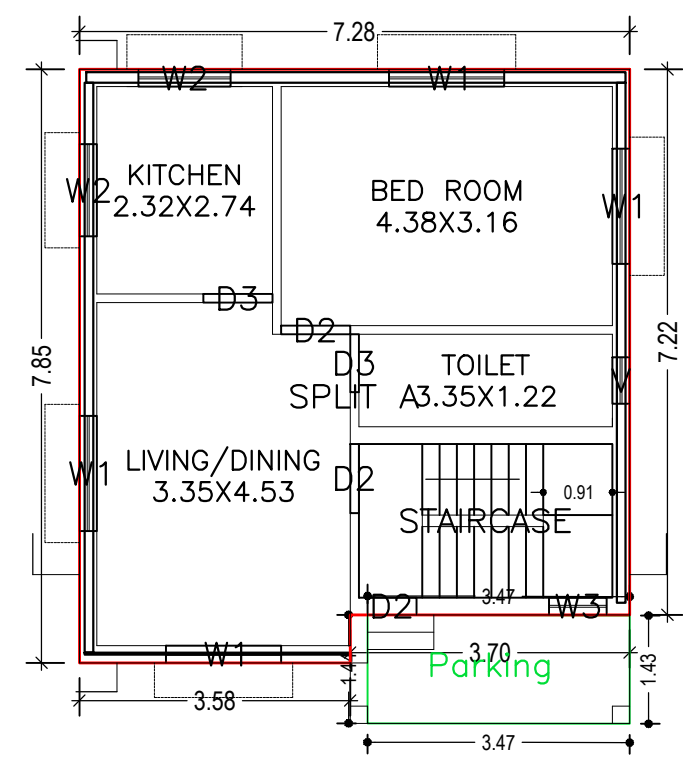

GROUND FLOOR PLAN  
(Proposed)  
SCALE 1:100

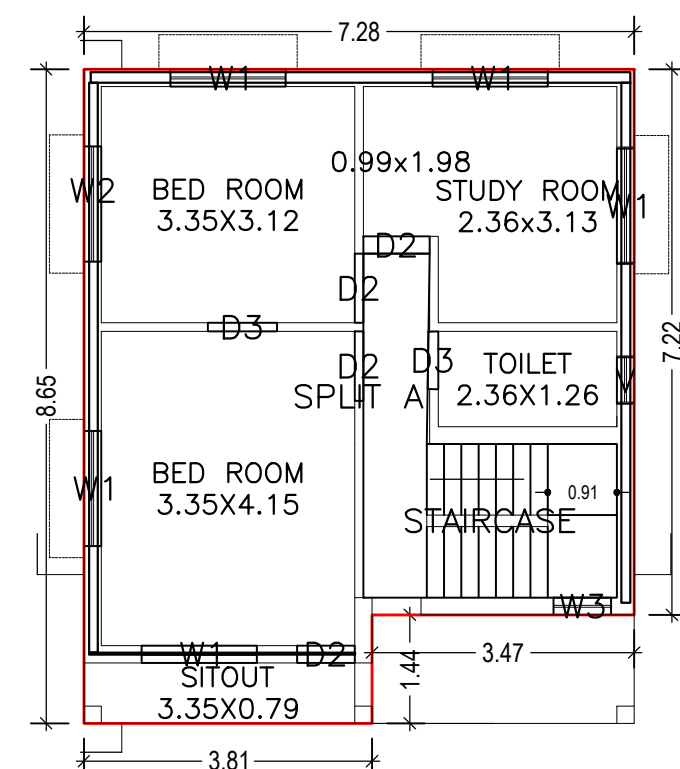

FIRST FLOOR PLAN  
(Proposed)  
SCALE 1:100

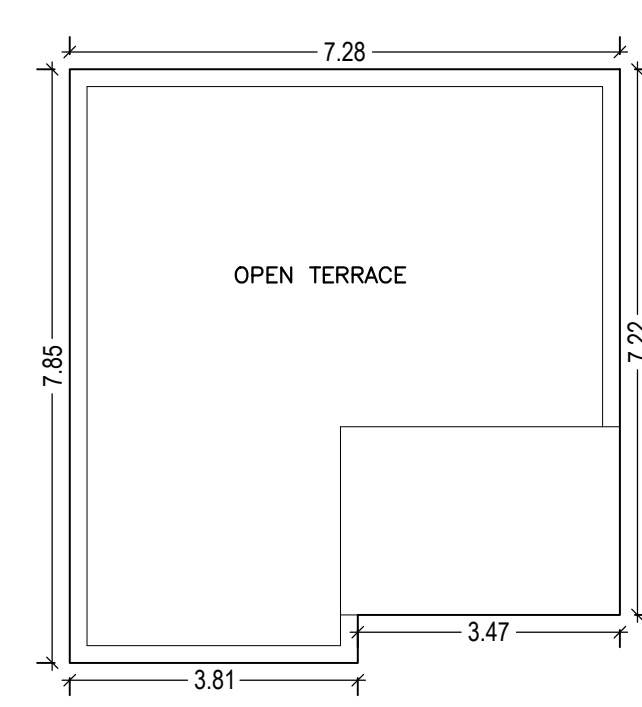

TERRACE FLOOR PLAN  
(SCALE 1:100)

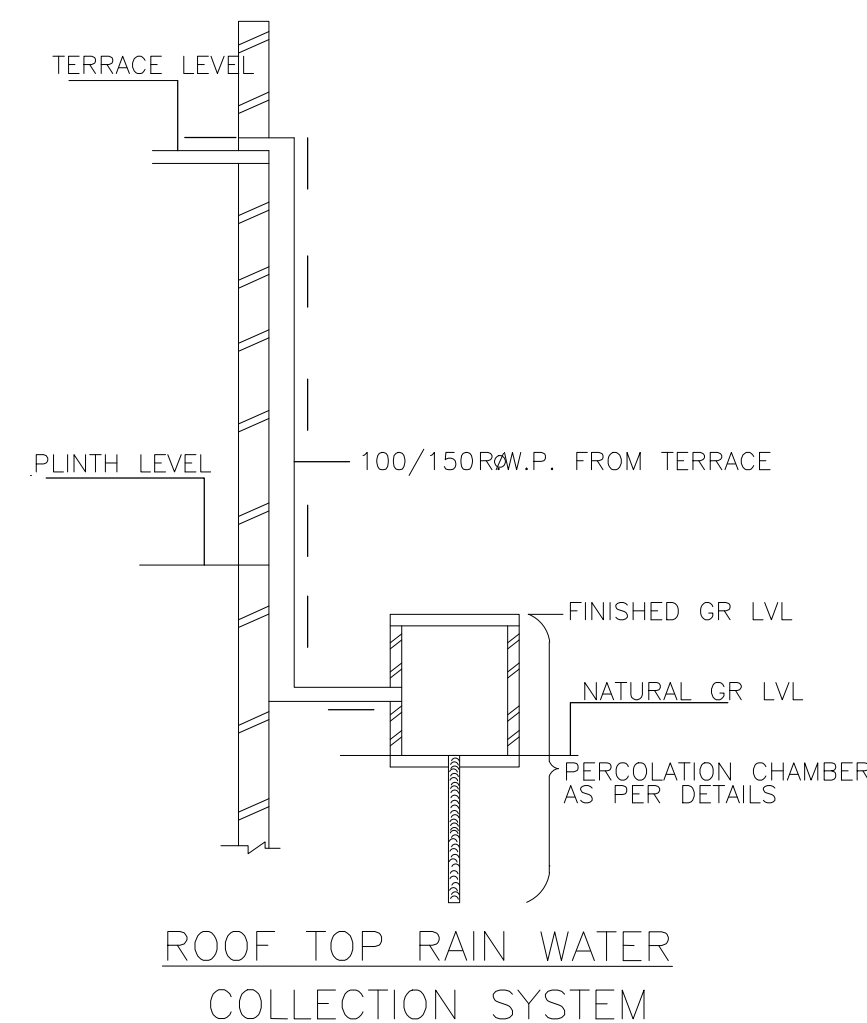

ROOF TOP RAIN WATER  
COLLECTION SYSTEM

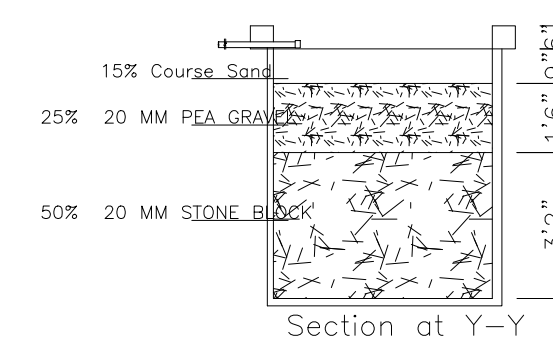

PLAN OF RECHARGE WELL  
Scale 1" = 4' 0"

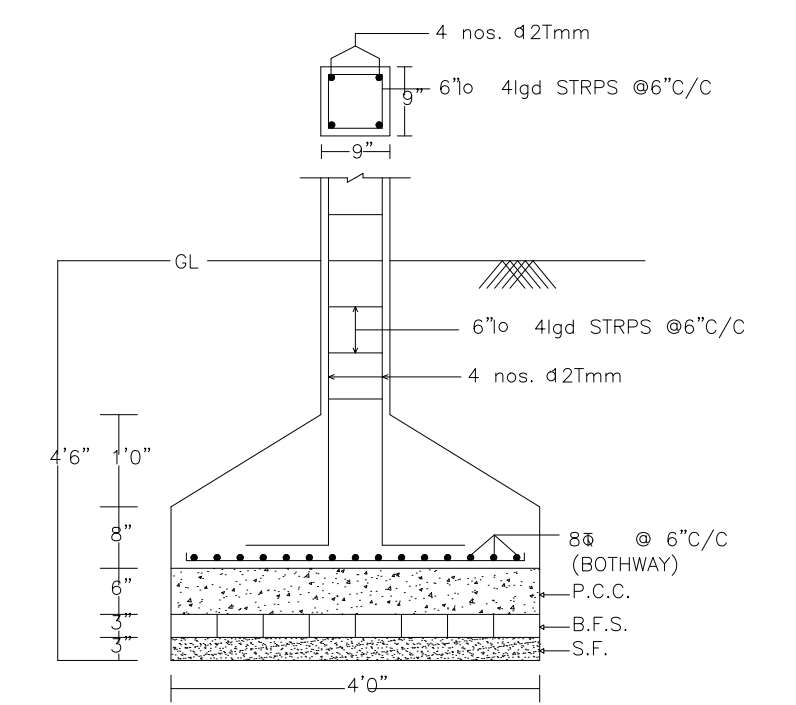

SECTION  
DETAIL OF COLUMNS

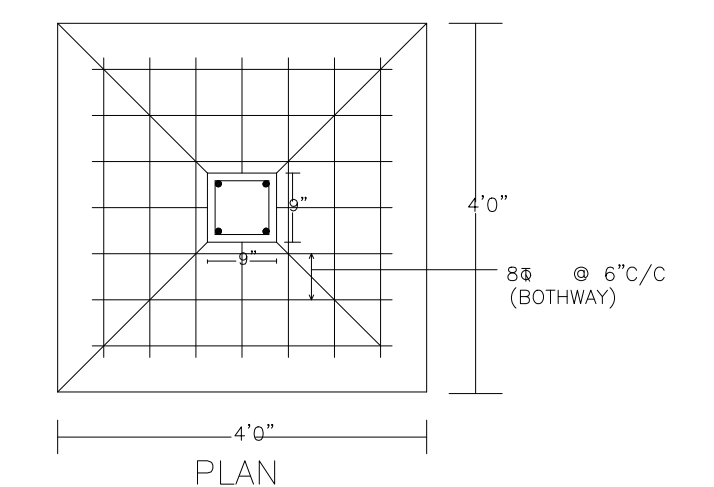

PLAN

LTP NAME AND SIGNATURE	STRUCTURAL ENG'S NAME AND SIGNATURE	BUILDER NAME AND SIGNATURE	DIGITAL SIGNATURE
KUMARI RINKU RANI DMC/ENG/0016/2016			