

Project Title :SMT. MANJU SHARMA

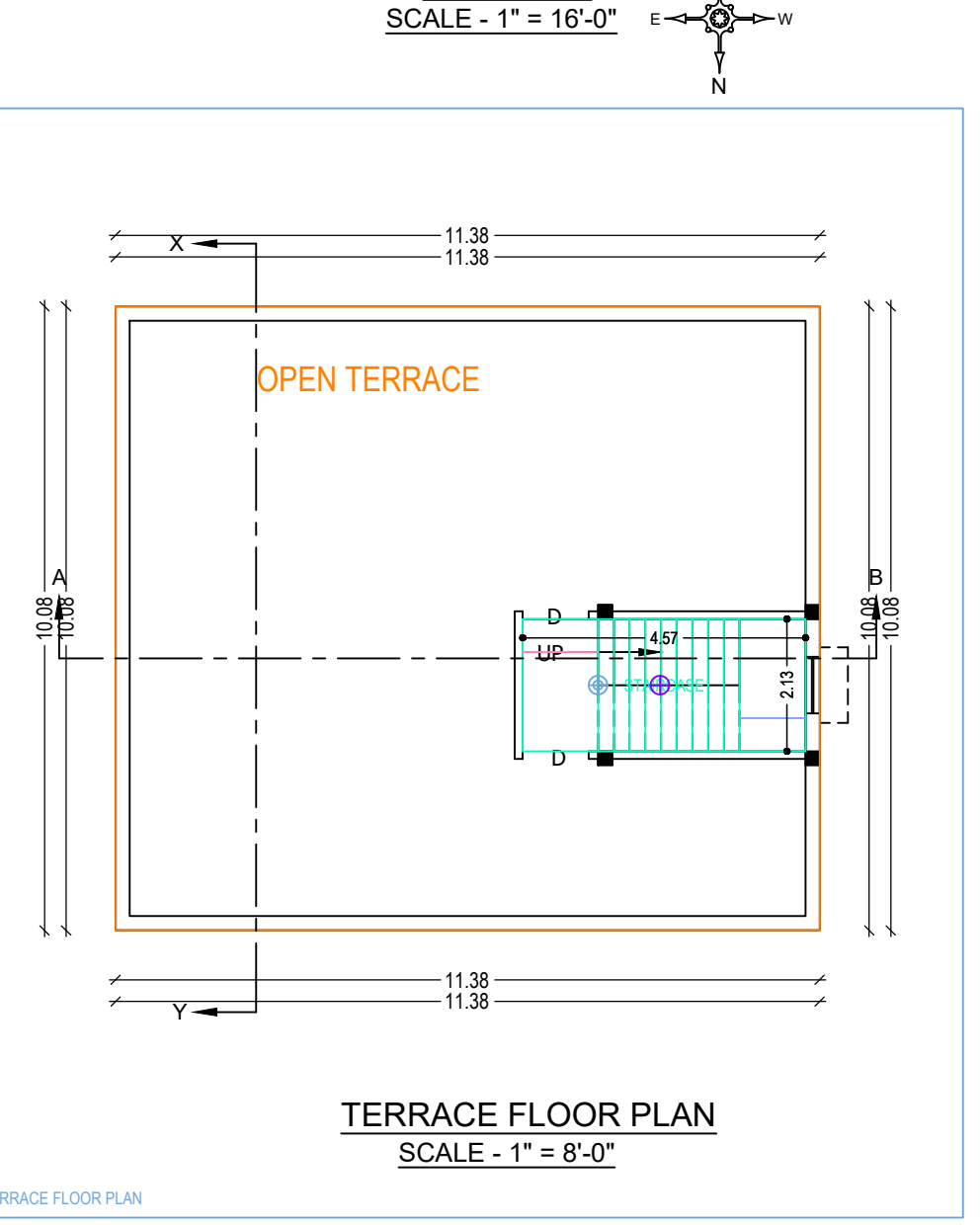
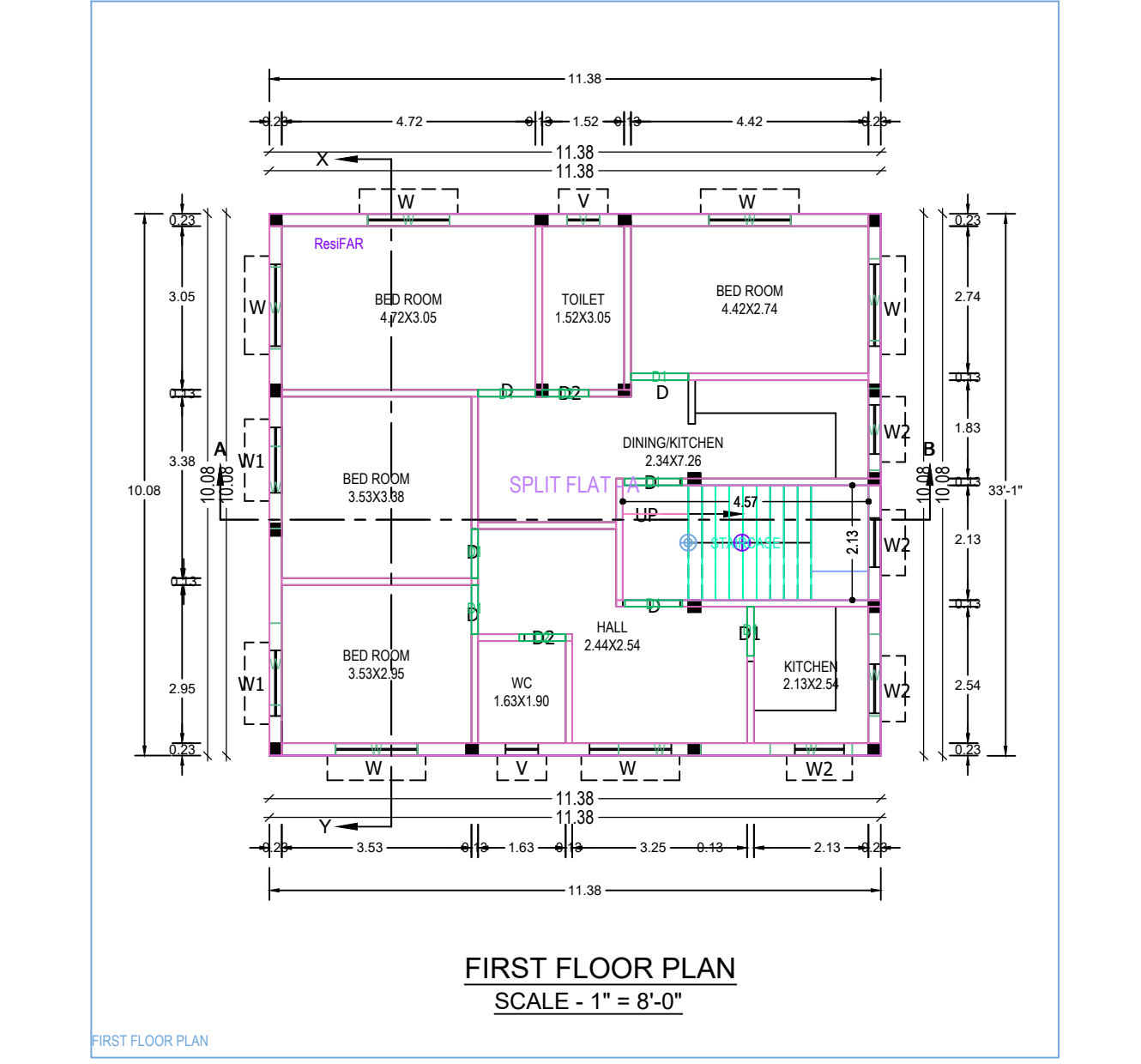
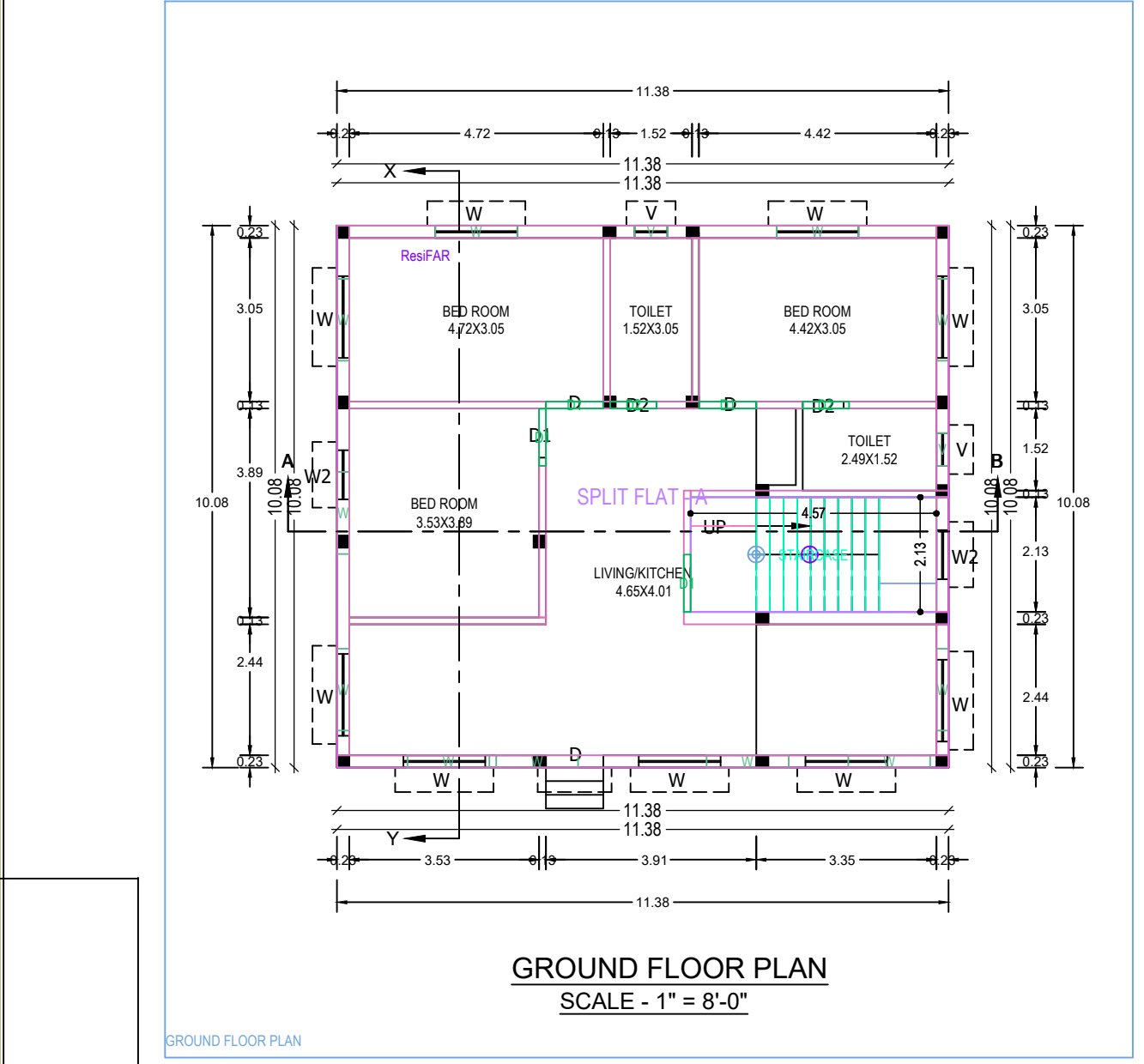
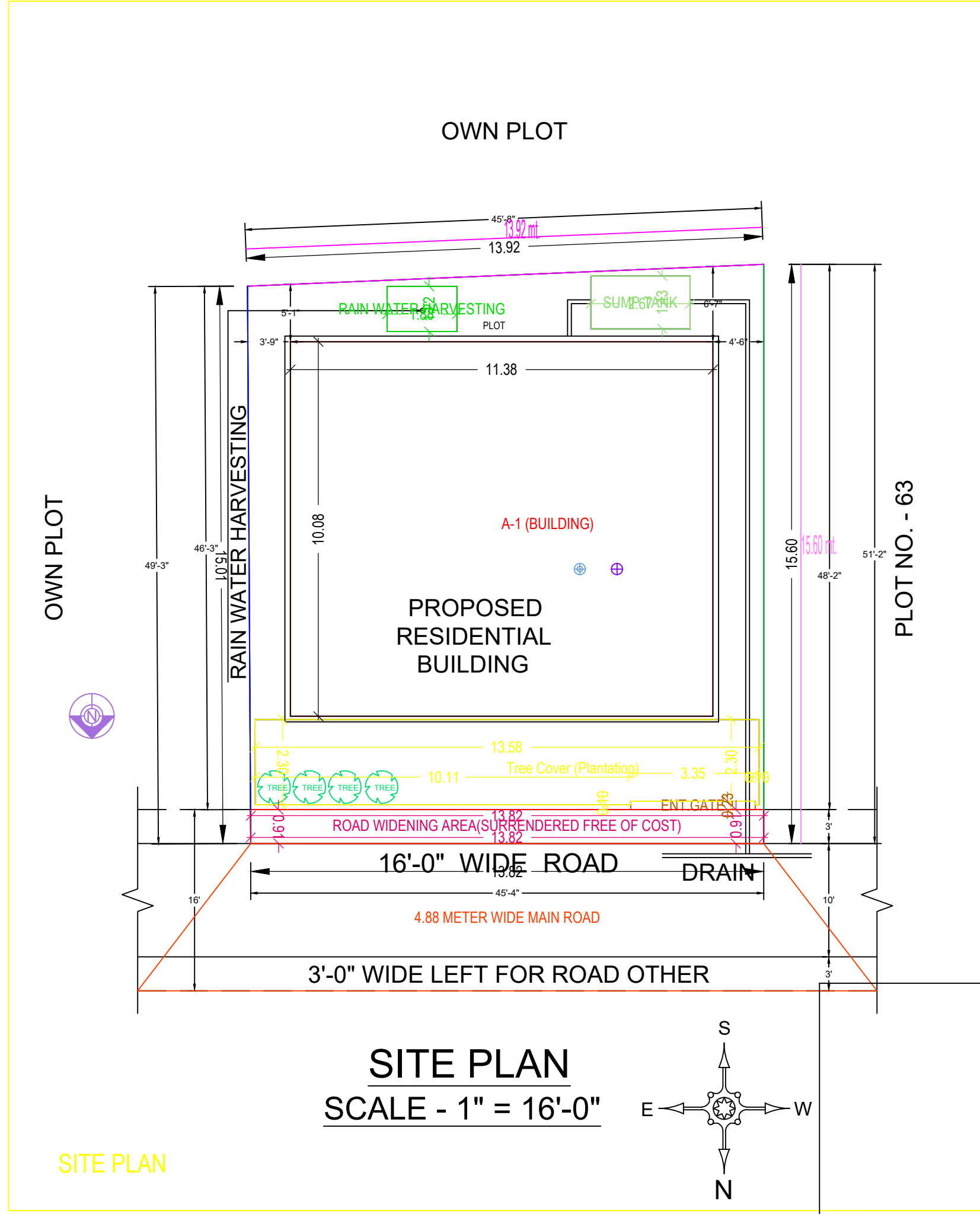
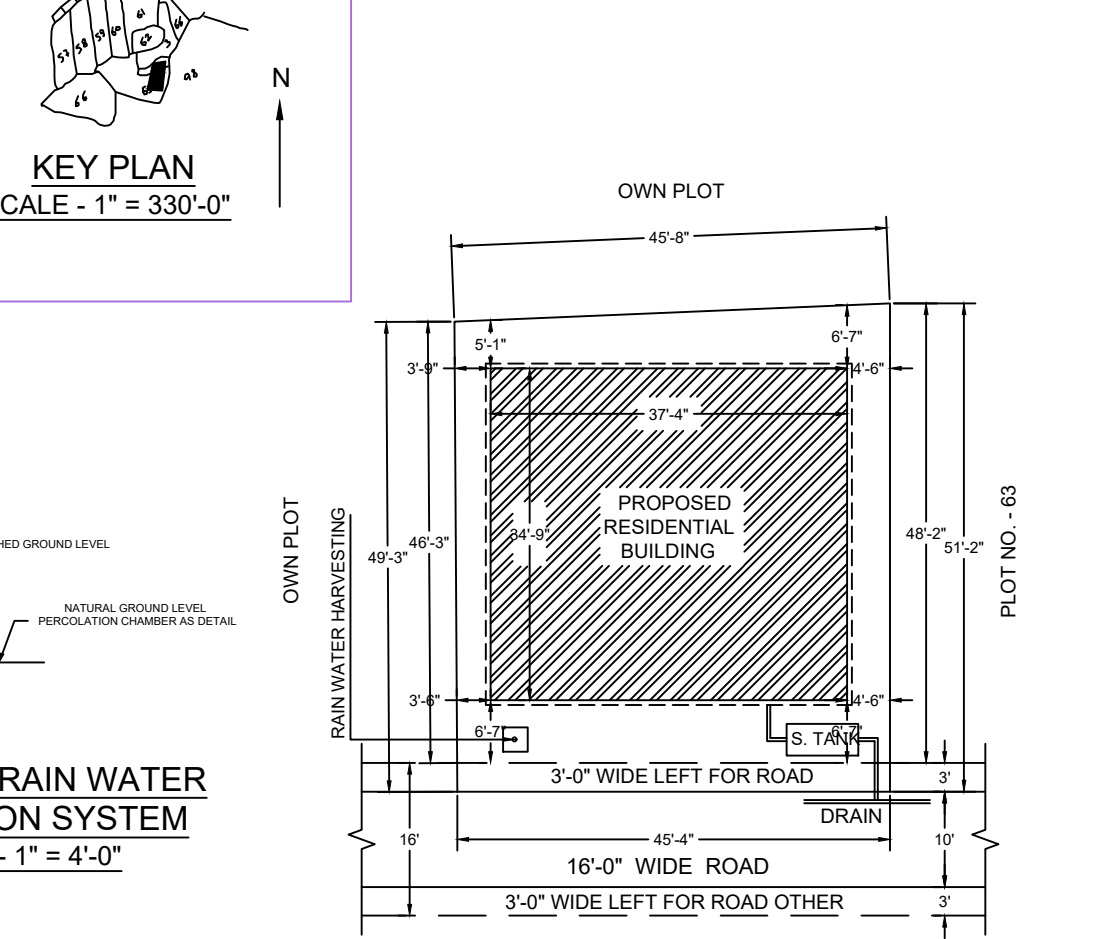
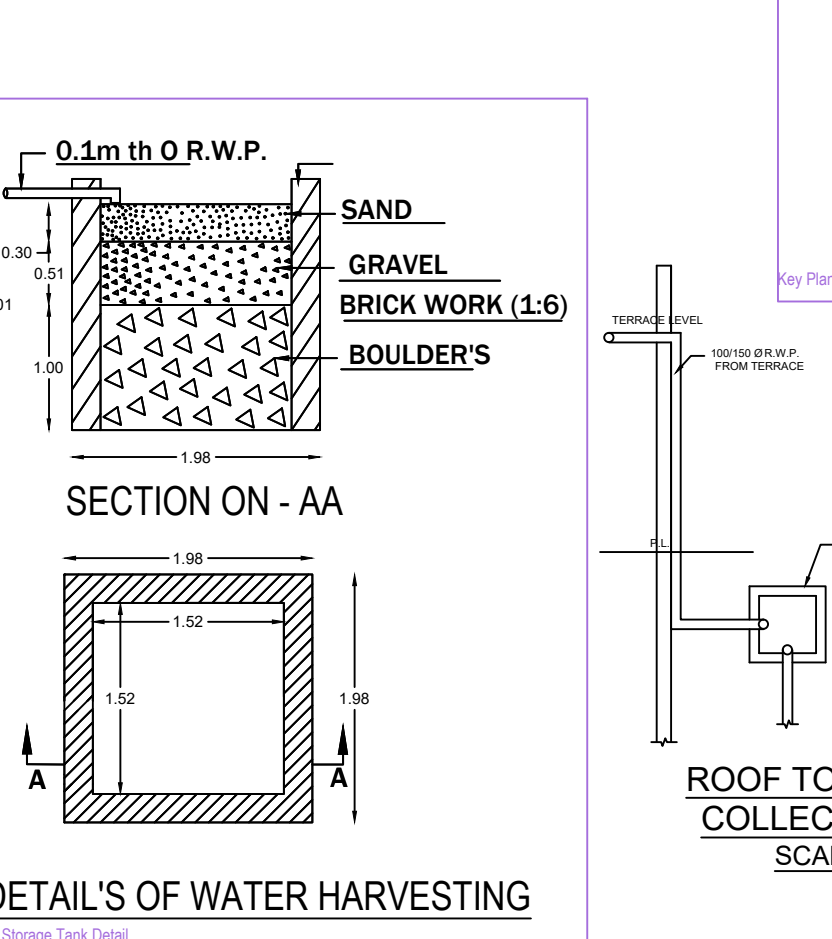
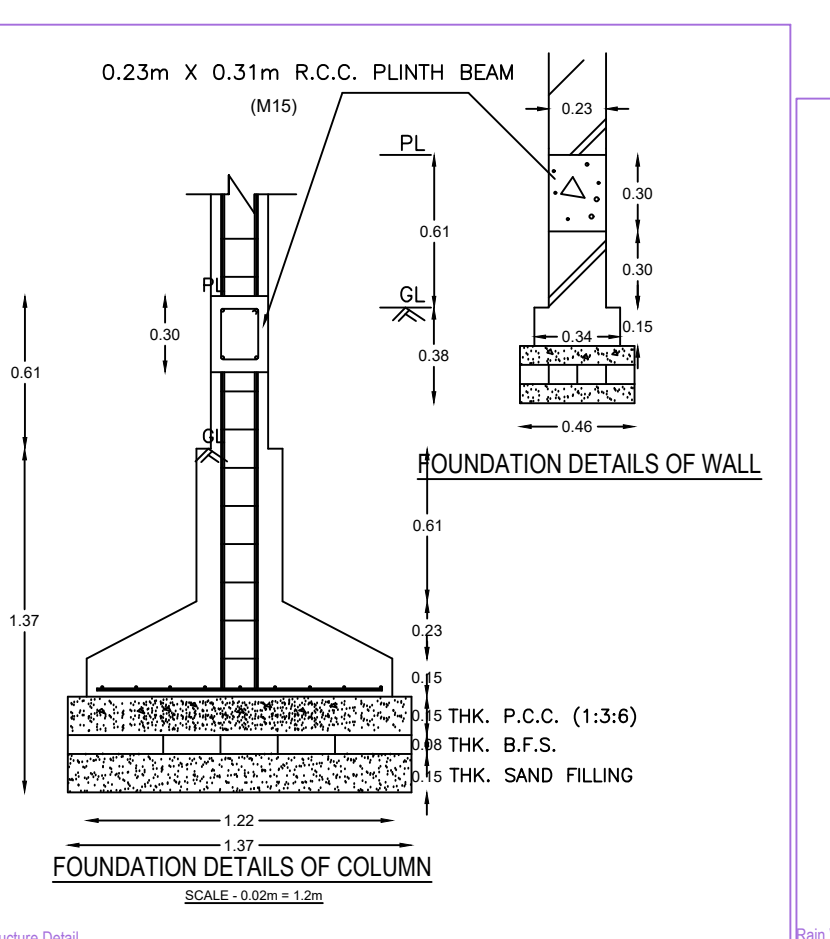
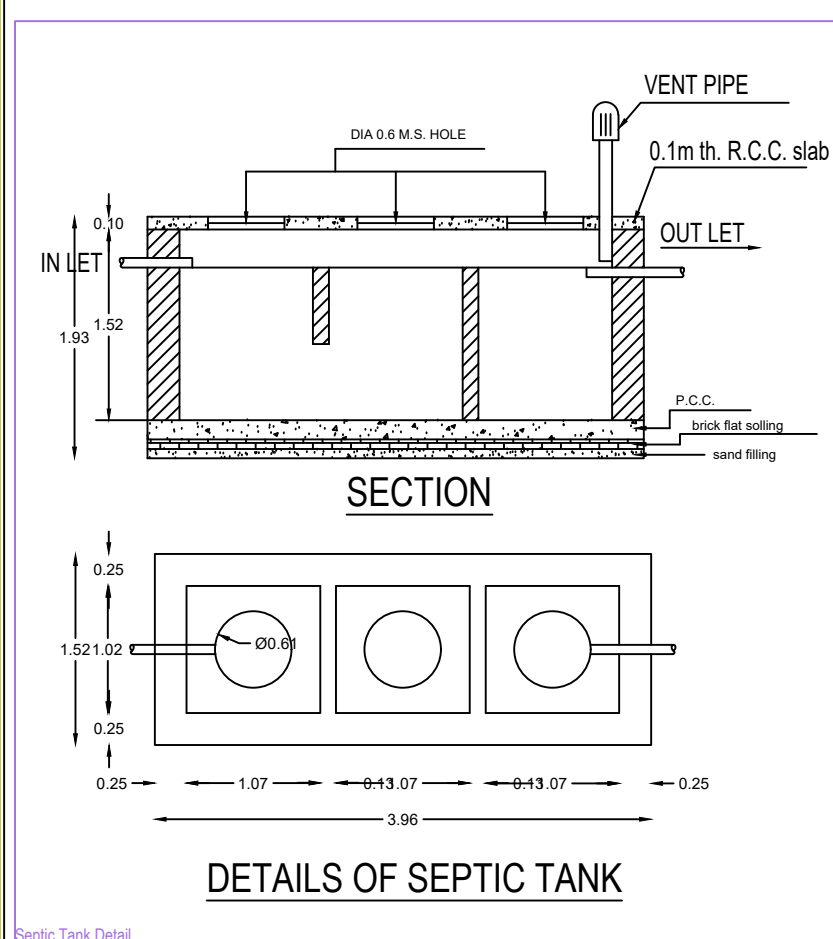
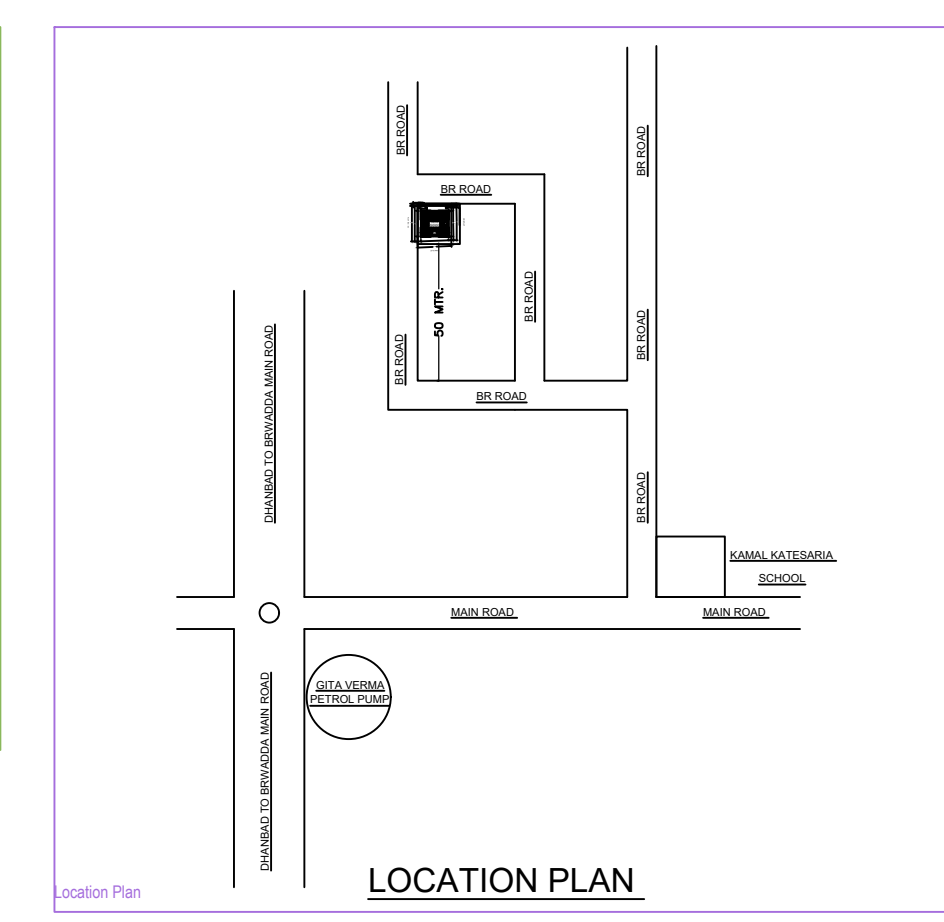
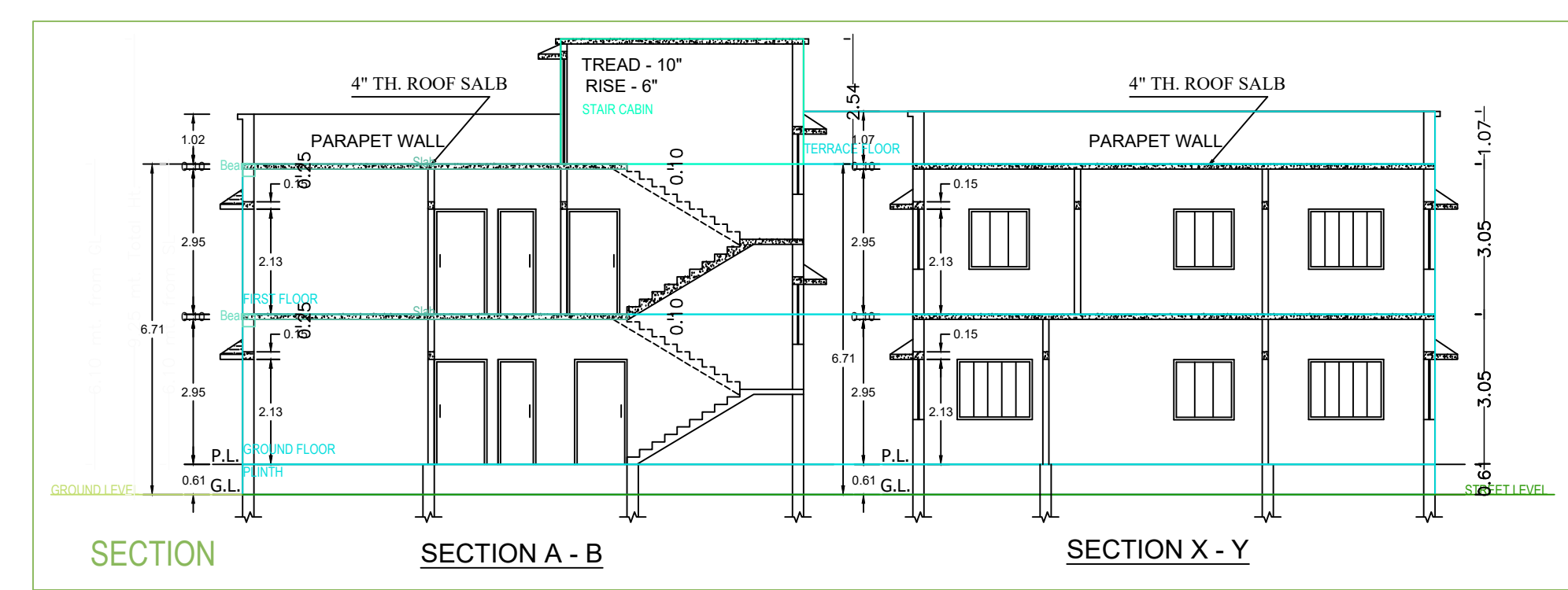
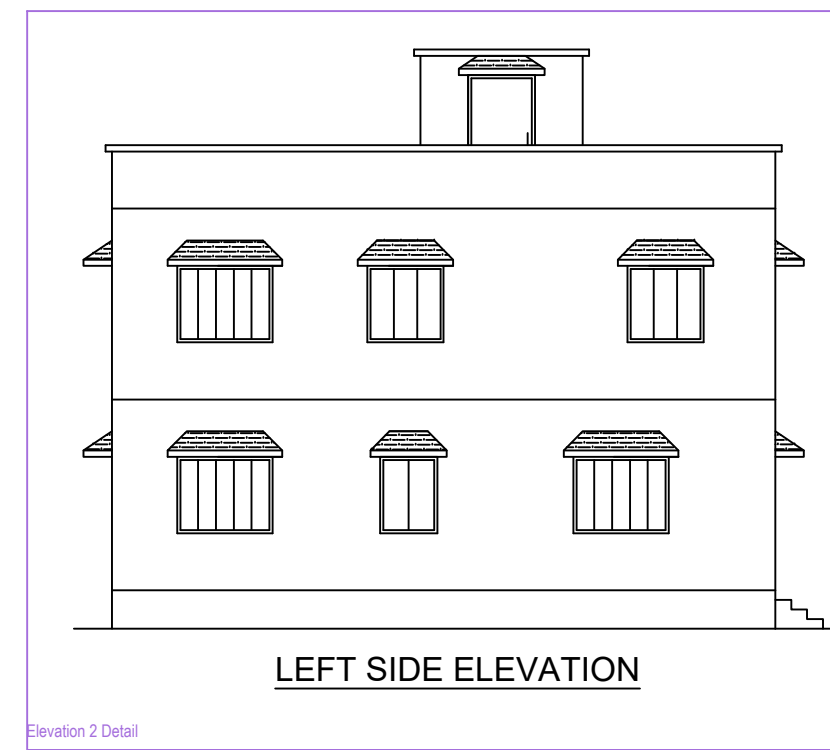
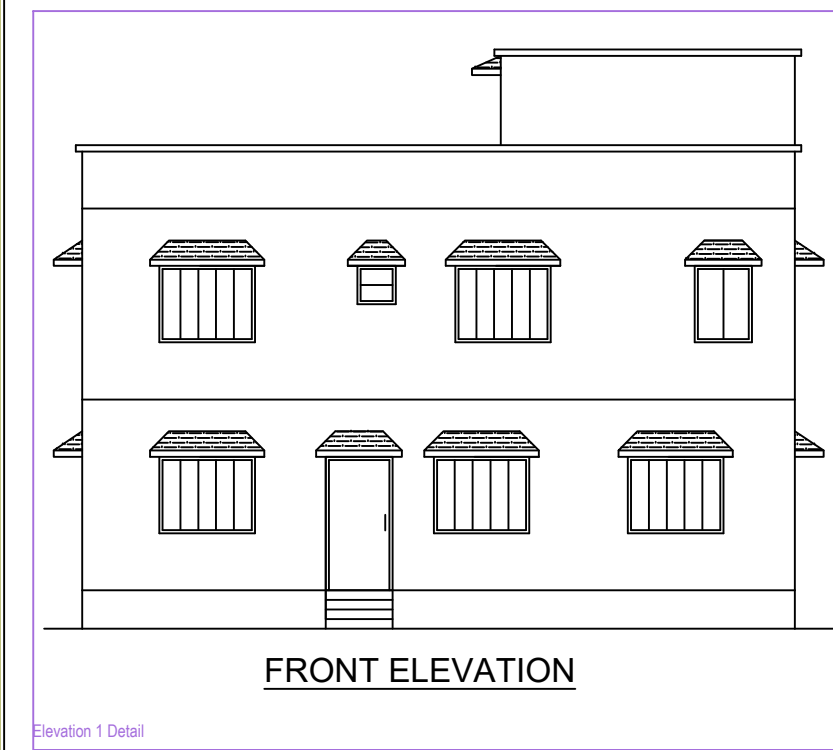

FOUNDATION : 6" th. P.C.C. (1:1.5:3) foundation bed & first class brick work in cement mortar (1:6) in foundation.

PLINTH : 1 1/2" th. D.P.C. (1:1.5:3) all round on the plinth level.

FLOORING : 1 1/2" th. P.S./ Marble flooring over 3" th. P.C.C. (1:3:6).

SUPERSTRUCTURE : First class brick work in cement mortar (1:6).

SLAB, BEAM & LINTEL : All R.C.C. works (1:1.5:3).

WOOD WORKS : All doors & windows frames of sal wood.

PLASTERING : 3/8" th. cement plaster (1:6) in both side.

STAIR CASE : RISE - 6", TREAD - 10"

SCHEDULE

D	3'-6" X 7'-0"	W	5'-0" X 4'-0"
D1	3'-0" X 7'-0"	W1	4'-0" X 4'-0"
D2	2'-6" X 7'-0"	W2	3'-0" X 4'-0"
		V	2'-0" X 2'-0"

DETAILS OF AREA

LAND AREA : 212.79 Sq.mtr. (AS PER DEED)
212.15 Sq.mtr. (AVAILABLE)

GROUND FLOOR AREA : 114.75 Sq.mtr.

FIRST FLOOR AREA : 114.75 Sq.mtr.

COVERED AREA : 229.50 Sq.mtr.

F.A.R. : 1.08

% OF PLINTH AREA : 54.09 %

TITLE OF DRAWING

PLAN FOR PROPOSED RESIDENTIAL BUILDING DRAWING OF SMT. MANJU SHARMA W/O SRI RAMESH SHARMA, UNDER MOUZA - BHELATAND, NO. - 89, KHATA NO. - 03, NEW KHATA NO. - 76, PLOT NO. - 65, NEW PLOT NO. - 103, DIST. - DHANBAD.

SIG. OF OWNER SIG. OF ENGINEER

AREA STATEMENT DHANBAD MUNICIPAL CORPORATION

VERSION NO. : 1.0.17
VERSION DATE : 01/01/2019

PROJECT DETAIL	Plot Use - Residential
Region - DHANBAD URBAN LOCAL BODIES	Plot Sub-Use - Bungalow Dwelling / Non Apartment
Project - DHANBAD	Level Use Zone - 18
Application Type - General Proposal	Adjoining Road Width -
Name of Development - New	Reference Survey No/Survey No -
Project Type - Building Permission	Thana No. -
Site Location -	Plot No. -
Village/Mouza Name -	Khata No. -
Ward No. -	North -
Road/Street -	South -
	East -
	West -

AREA DETAILS:

AREA OF PLOT (Minimum)	(A)	52.00
Deduction for Net Plot Area		212.15
Summery Area of Plot		12.84
Total		12.84
Net Plot Area (Gross Plot Area - Deduction from Gross Plot Area)	(A-Deductions)	199.52
Free Other Net Area		12.64
COF Area		35.86
Total		43.50
Balance Plot Area (Net Plot Area - Recreational/Amenity space)	(A-Deductions)	166.05
Plot Area for Coverage (Net Plot Area - Road/Widening Area)	(A-Deductions)	199.52
Plot Area for FSI (Net Plot Area - Road/Widening Area)	(A-Deductions)	212.15

COVERAGE CHECK

Proposed Coverage Area (0.25 %)	114.75
Total Coverage Area (3.5 %)	114.75

FAR CHECK

Proposed Area of FAR	229.50
Total Area of FAR	229.50

BUILT UP AREA CHECK

Total Proposed Built up Area	229.50
ARCHT ENGR/SUPERVISOR (Sign)	OWNER
DEVELOPMENT AUTHORITY	LOCAL BODY

COLOR INDEX

FLY BOUNDARY	Red
ADJOINING ROAD	Green
PROPOSED WORK (COVERAGE AREA)	Blue
EXISTING (To be retained)	Yellow
EXISTING (To be demolished)	White

MARGIN DETAIL:

Building / Wing	Road Name	Front Margin	Rear Margin	Side Margin	Side Margin
A (BUILDING)	ROAD WIDENING AREA (UNRESERVED FREE OF COST)	2.51	1.55	1.09	1.37

FAR & Tenement Details (Table 4c-1)

Building	No. of Same Bldg	Total Built Up Area (Sq.mt)	Proposed FAR Area (Sq.mt)	Total FAR Area (Sq.mt)	Tent (No.)
A (BUILDING)	1	229.50	229.50	229.50	01
Grand Total	1	229.50	229.50	229.50	01

Building A (BUILDING)

Floor Name	Total Built Up Area (Sq.mt)	Proposed FAR Area (Sq.mt)	Total FAR Area (Sq.mt)	Tent (No.)
Ground Floor	114.75	114.75	114.75	01
First Floor	114.75	114.75	114.75	01
Terrace Floor	0.00	0.00	0.00	01
Total	229.50	229.50	229.50	01

SCHEDULE OF JOINERY:

BUILDING NAME	NAME	LENGTH	HEIGHT	NOS
A (BUILDING)	D2	0.86	2.10	04
A (BUILDING)	D1	0.91	2.10	03
A (BUILDING)	D1	1.07	2.10	08
Total	-	-	-	15

SCHEDULE OF JOINERY:

BUILDING NAME	NAME	LENGTH	HEIGHT	NOS
A (BUILDING)	V	0.61	1.00	03
A (BUILDING)	W	1.52	1.20	22
Total	-	-	-	25

UnitBUA Table for Building A (BUILDING)

FLOOR	Name	UnitBUA Type	UnitBUA Area	Carpet Area	No. of Rooms	No. of Tenement
GROUND FLOOR	SPLIT FLAT - A	FLAT	209.01	179.71	6	1
Total	-	-	209.01	179.71	15	1