

Proposal Basic Information

Proposal File No.	DMC/BP/0011/W23/2019
Owner Name	Smt. Nibedita Sinha & Sri. Jiten Kumar Sinha
Khata No	Old - 81 & New - 250
Plot No	Old - 969 & New - 1923
Village Name	Kolakusma
Use	Residential
SubUse	Bungalow/ Dwelling / Non Apartment

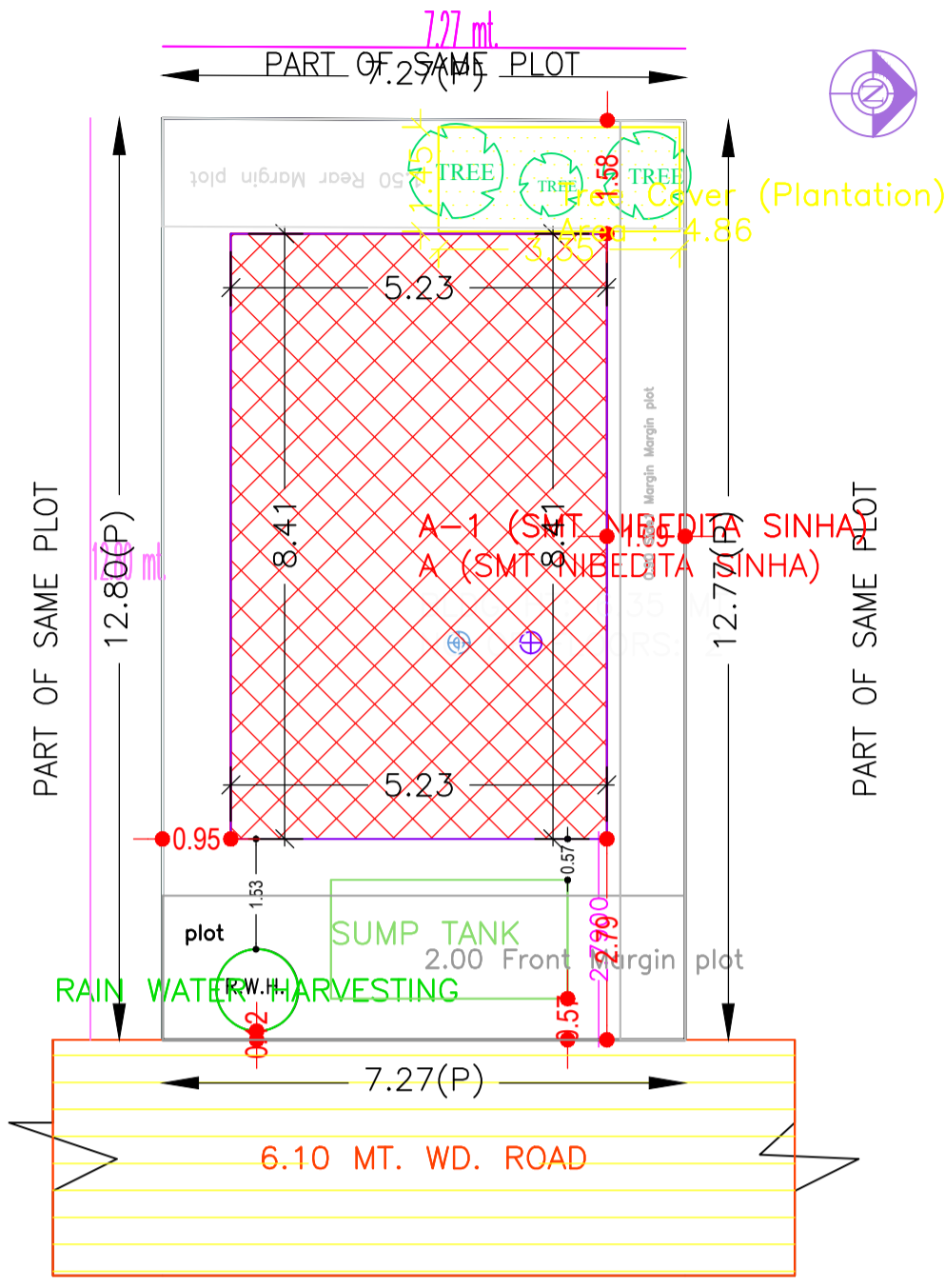

SITE PLAN

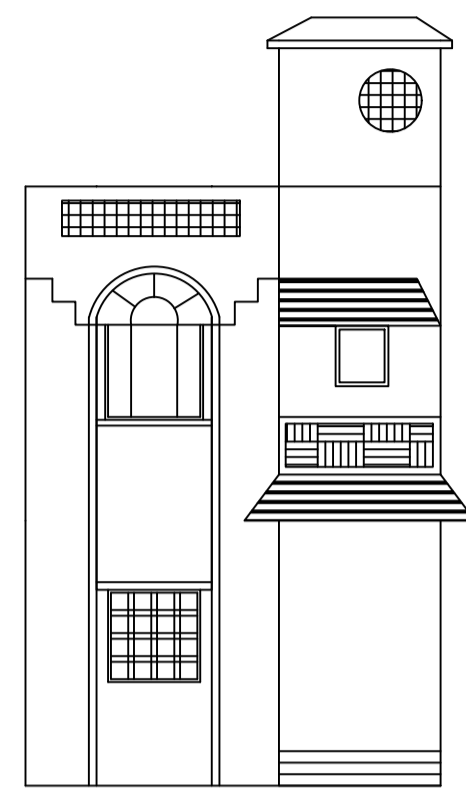

FRONT ELEVATION

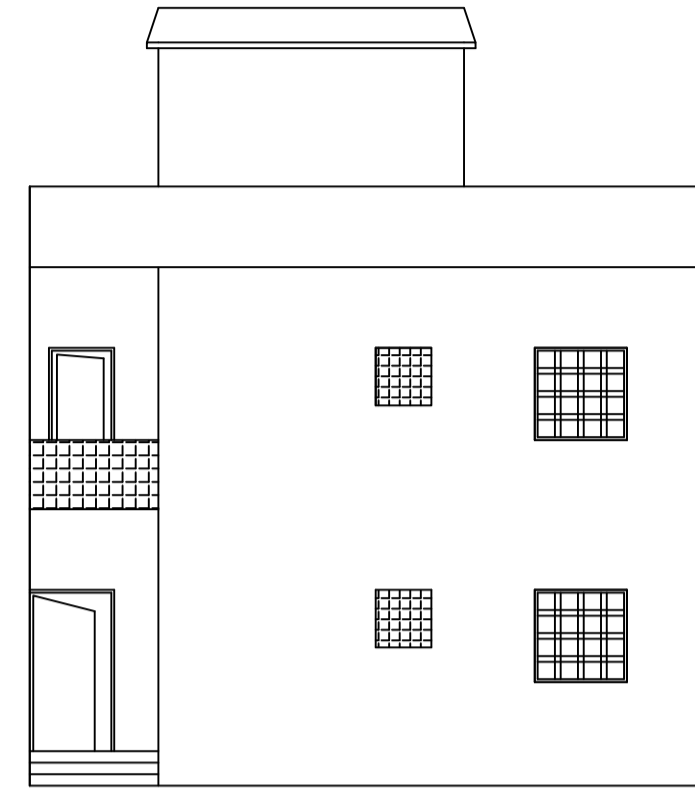

RIGHT SIDE ELEVATION

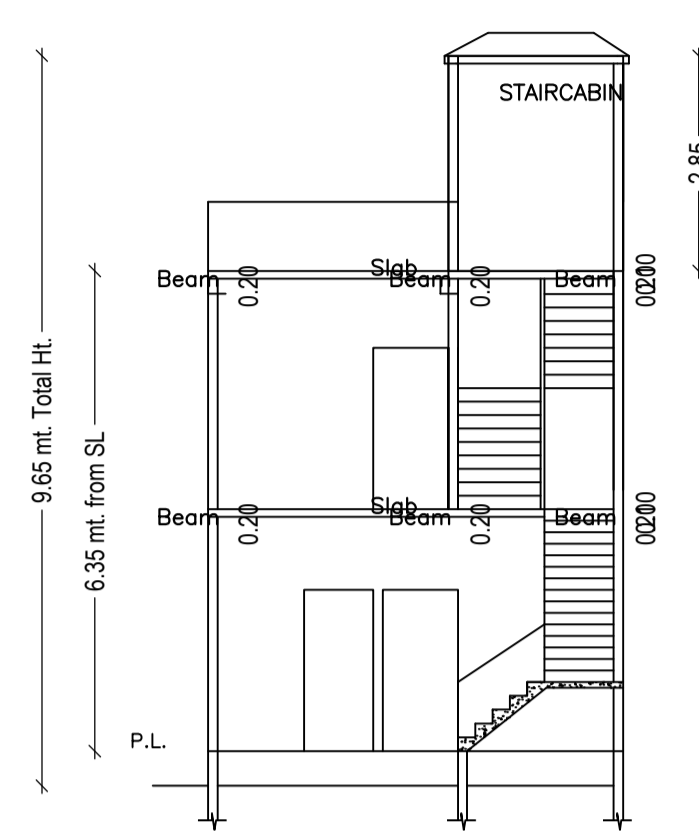

SECTION AT- X:X

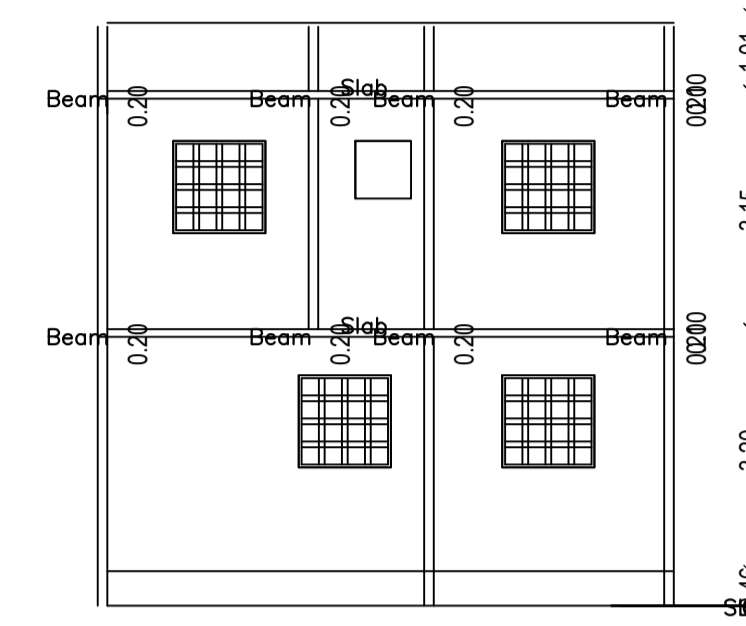

SECTION AT- Y:Y

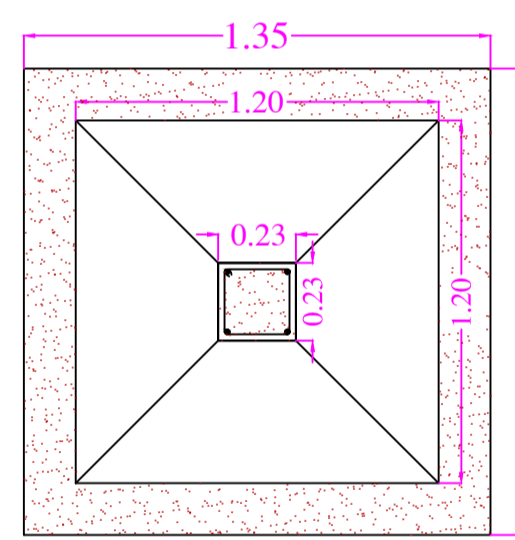
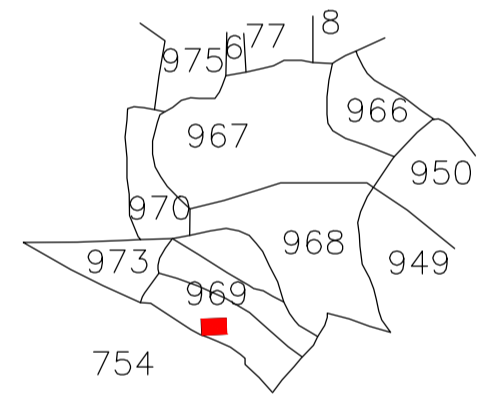

FOUNDATION PLAN

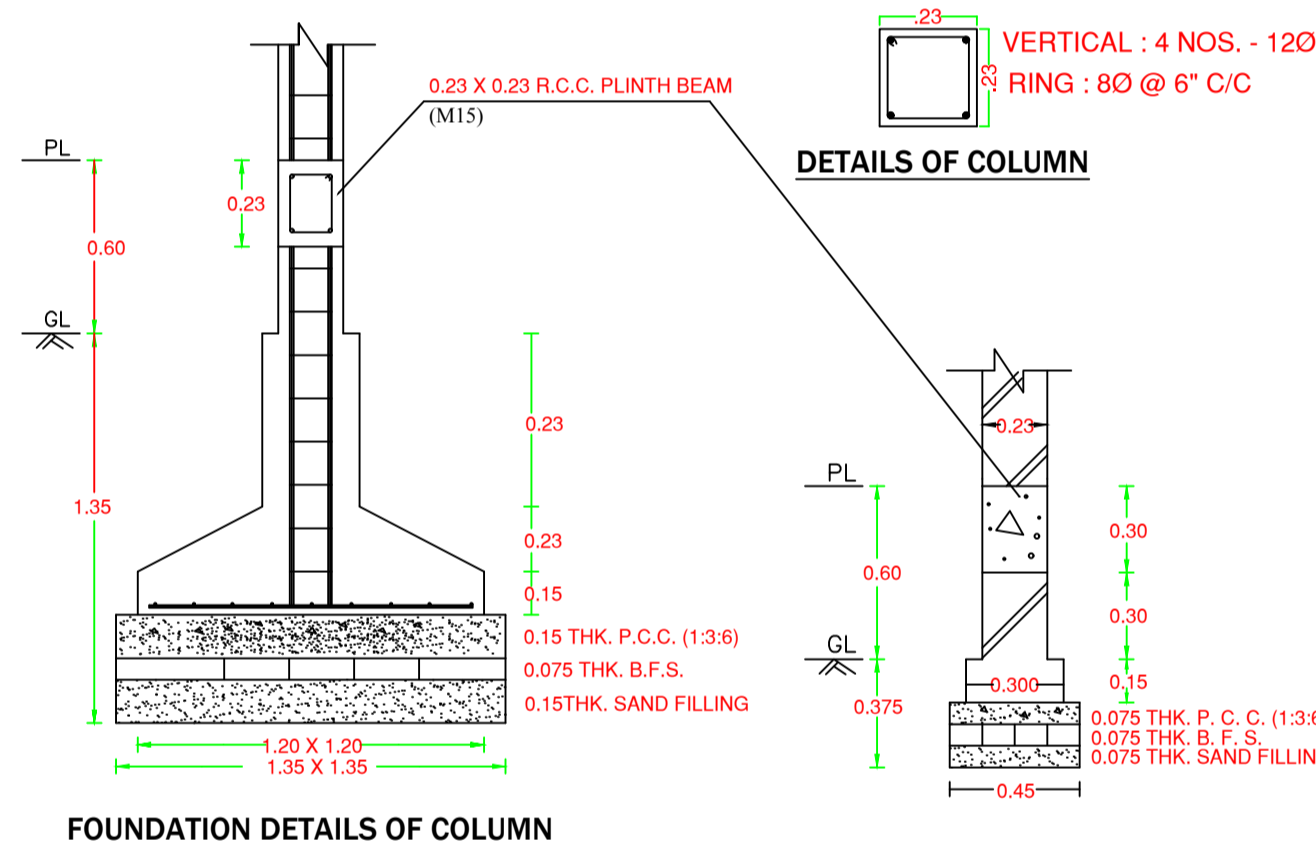

DETAILS OF COLUMN

FOUNDATION DETAILS OF WALL

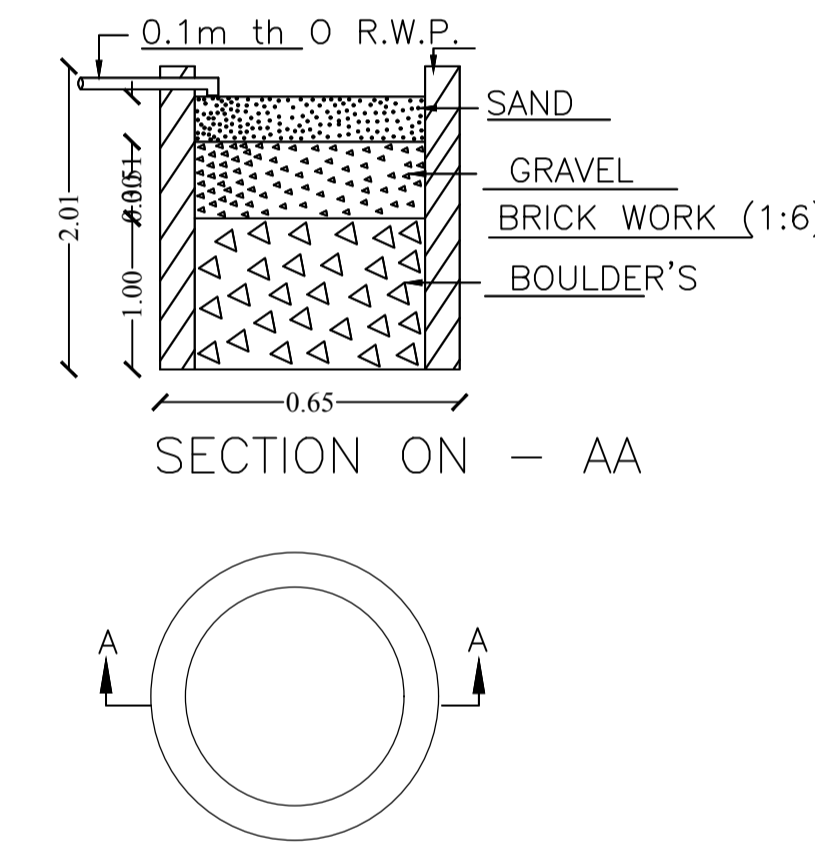

SECTION ON - AA

DETAIL'S OF WATER HARVESTING

AREA STATEMENT DHANBAD MUNICIPAL CORPORATION	VERSION NO. : 1.0.32 VERSION DATE: 10/05/2018	SQ.MT.
PROJECT DETAIL:		
Region: JHARKHAND URBAN	Plot Use: Residential	
LOCAL BODIES	Plot SubUse: Bungalow/ Dwelling / Non Apartment	
District: DHANBAD	PlotNearby/ReligiousStructure: NA	
Authority: DHANBAD MUNICIPAL CORPORATION	Inward No: DMC/BP/0011/W23/2019	
Application Type: General Proposal	Plot/SubPlot No: Old - 969 & New - 1923	
Project Type: Building Permission	North: Plot No. - Part of Same Plot	
Nature of Development: New	South: Plot No. - Part of Same Plot	
Location of Development Area: Old Area	East: Road Width - 6.09 M. Wide Proposed Road	
Area	West: Plot No. - Part of Same Plot	
AREA DETAILS:		
AREA OF PLOT (Minimum)	(A)	92.90
NET AREA OF PLOT(Gross Plot Area - Deduction from Gross Plot area)	(A-Deductions)	92.90
Deduction for Balance Plot Area(from Gross Plot Area)		
Common Plot		4.88
Total		4.88
BALANCE AREA OF PLOT(Net Plot Area - Recreational/Amenity space)	(A-Deductions)	88.04
PLOT AREA FOR COVERAGE(Net Plot Area)	(A-Deductions)	92.90
Plot Area for FAR (Net Plot Area + Road Widening Area)	(A-Deductions)	92.90
COVERAGE CHECK		
Permissible Coverage area (70.00 %)		65.03
Proposed Coverage Area (47.32 %)		43.96
Total Prop. Coverage Area (47.32 %)		43.96
Balance coverage area (22.68 %)		21.07
FAR CHECK		
Perm. FAR Area (2.50)		232.25
Total Perm. FAR area		232.25
Residential FAR		87.92
Proposed FAR Area		87.92
Total Proposed FAR Area		87.92
Consumed FAR (Factor)		0.95
Balance FAR Area		144.33
BUILT UP AREA CHECK		
Total Proposed BuiltUp Area		87.92
ARCHITECT (Regd)		Kumud Kanchan
ENGINEER (Regd)		
SUPERVISOR (Regd)		
OWNER (Regd)		Smt. Nibedita Sinha & Sri. Jiten Kumar Sinha
DEVELOPMENT AUTHORITY		LOCAL BODY

COLOR INDEX	
PLOT BOUNDARY	[Red Line]
ABUTTING ROAD	[Green Line]
PROPOSED CONSTRUCTION	[Red Area]
COMMON PLOT	[Yellow Area]
ROAD WIDENING AREA	[Blue Area]
EXISTING (To be retained)	[Blue Area]
EXISTING (To be demolished)	[Yellow Area]

SCHEDULE OF DOOR:

BUILDING NAME	NAME	LENGTH	HEIGHT	NOS
A (SMT NIBEDITA SINHA)	D1	0.75	2.10	01
A (SMT NIBEDITA SINHA)	D	0.90	2.10	06
A (SMT NIBEDITA SINHA)	D2	1.93	2.10	01

SCHEDULE OF WINDOW/VENTILATION:

BUILDING NAME	NAME	LENGTH	HEIGHT	NOS
A (SMT NIBEDITA SINHA)	V	0.60	1.20	01
A (SMT NIBEDITA SINHA)	W	1.07	1.20	02
A (SMT NIBEDITA SINHA)	W	1.20	1.20	11
A (SMT NIBEDITA SINHA)	W1	1.93	2.10	

FAR & Tenement Details (Table 4c-1)

Building	No. of Same Bldg	Total Built Up Area (Sq.mt.)	Proposed FAR Area (Sq.mt.)	Total FAR Area (Sq.mt.)	Total Consumed Additional FAR Area (Sq.mt.)	Tnmt (No.)
A (SMT NIBEDITA SINHA)	1	87.92	87.92	87.92	87.92	01
Grand Total :	1	87.92	87.92	87.92	87.92	01

UnitBUA Table for Building :A (SMT NIBEDITA SINHA)

FLOOR	Name	UnitBUA Type	UnitBUA Area	Carpet Area	No. of Rooms	No. of Tenement
GROUND FLOOR PLAN	SPLIT Smt. Nibedita Sinha & Sri. Jiten Kumar	FLAT	71.38	65.20	4	1
FIRST FLOOR PLAN	SPLIT Smt. Nibedita Sinha & Sri. Jiten Kumar	FLAT	0.00	0.00	5	0
Total:	-	-	71.38	65.20	9	1

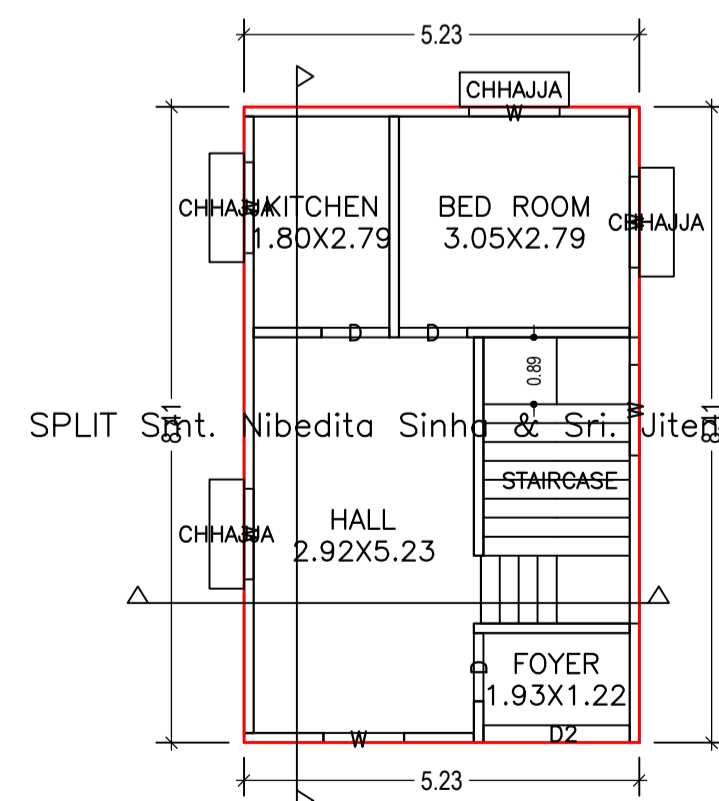

GROUND FLOOR PLAN (Proposed) (SCALE 1:100)

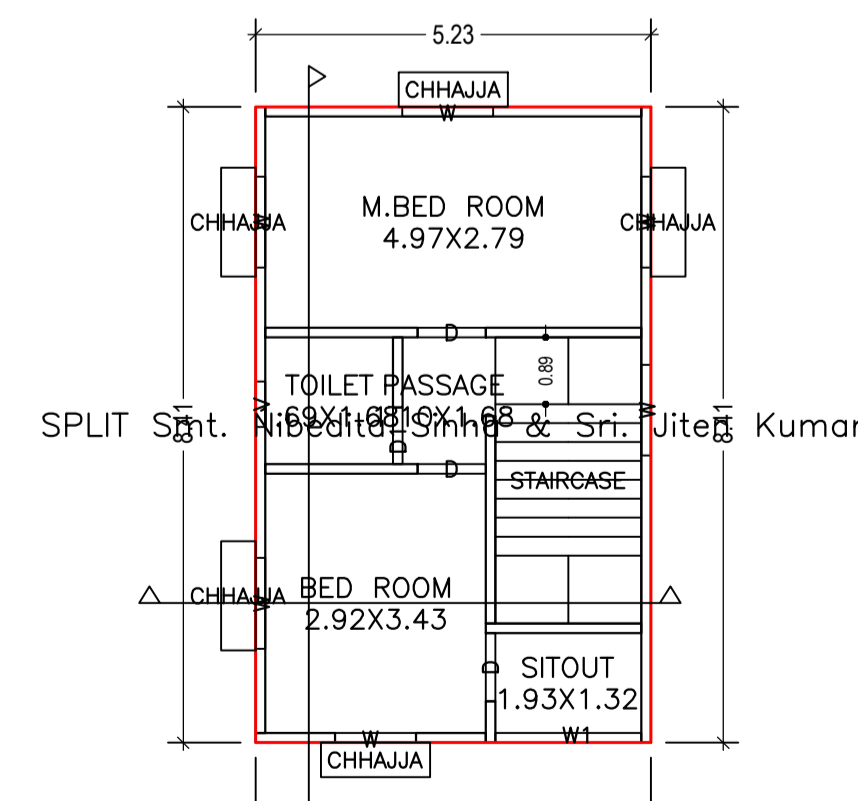

FIRST FLOOR PLAN (Proposed) (SCALE 1:100)

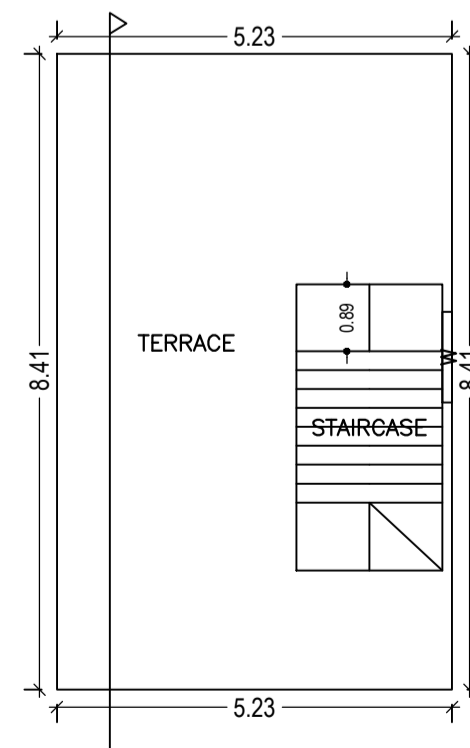

TERRACE FLOOR PLAN (SCALE 1:100)

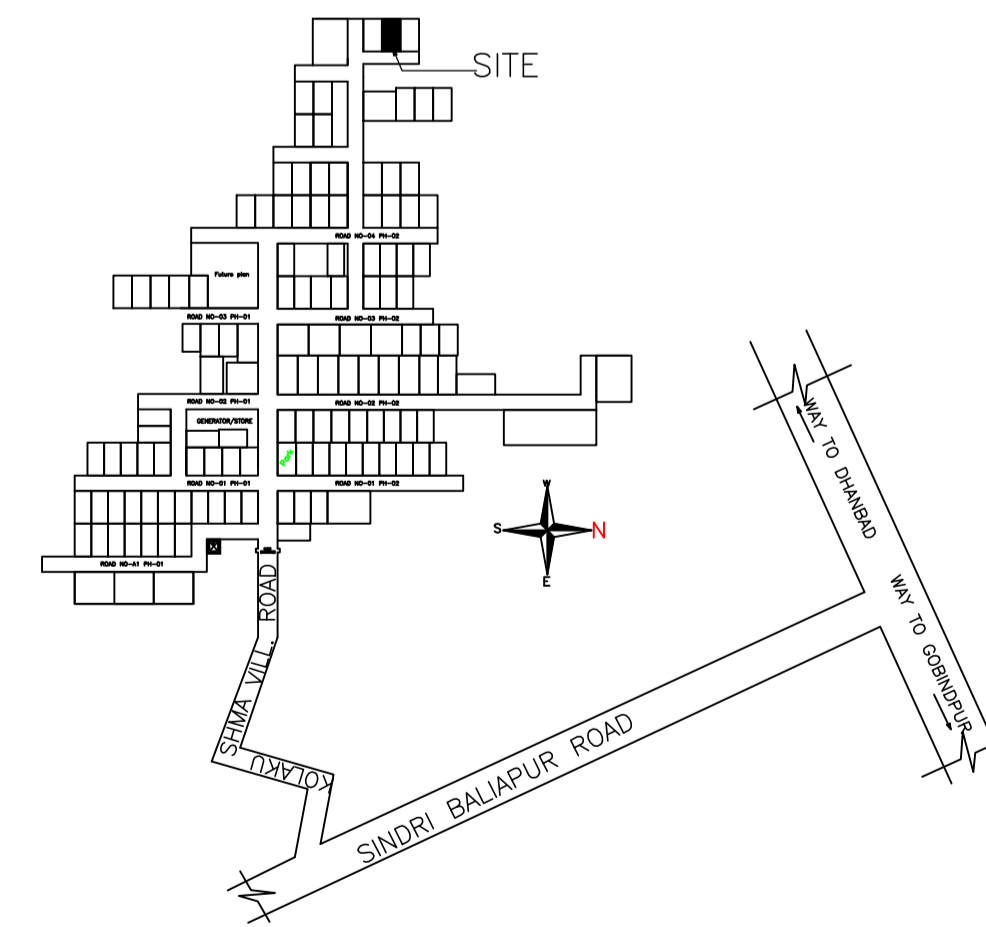

Buildingwise Floor FAR Details

Floor Name	Building Name A (SMT NIBEDITA SINHA)		Total	
	Proposed Built Up Area (Sq.mt.)	Proposed FAR Area (Sq.mt.)	Total Proposed Built Up Area (Sq.mt.)	Total FAR Area (Sq.mt.)
Ground Floor	43.96	43.96	43.96	43.96
First Floor	43.96	43.96	43.96	43.96
Terrace Floor	0.00	0.00	0.00	0.00
Total :	87.92	87.92	87.92	87.92

Building :A (SMT NIBEDITA SINHA)

Floor Name	Total Built Up Area (Sq.mt.)	Proposed FAR Area	Total FAR Area (Sq.mt.)	Total Consumed Additional FAR Area (Sq.mt.)	Tnmt (No.)
		Resi.			
Ground Floor	43.96	43.96	43.96	43.96	01
First Floor	43.96	43.96	43.96	43.96	00
Terrace Floor	0.00	0.00	0.00	0.00	00
Total :	87.92	87.92	87.92	87.92	01
Total Number of Same Buildings	1				
Total :	87.92	87.92	87.92	87.92	01

Building USE/SUBUSE Details

Building Name	Building Use	Building SubUse	Building Structure
A (SMT NIBEDITA SINHA)	Residential	Bungalow/ Dwelling / Non Apartment	Non-Highrise

LTP NAME AND SIGNATURE Kumud Kanchan DMC/ARC/0002/2016	STRUCTURAL ENG'S NAME AND SIGNATURE	BUILDER NAME AND SIGNATURE	DIGITAL SIGNATURE
--	-------------------------------------	----------------------------	-------------------

Proposal Basic Information

Proposal File No.	DMC/BP/0011/W23/2019
Owner Name	Smt. Nibedita Sinha & Sri. Jiten Kumar Sinha
Khata No	Old - 81 & New - 250
Plot No	Old - 969 & New - 1923
Village Name	Kolakusma
Use	Residential
SubUse	Bungalow/ Dwelling / Non Apartment

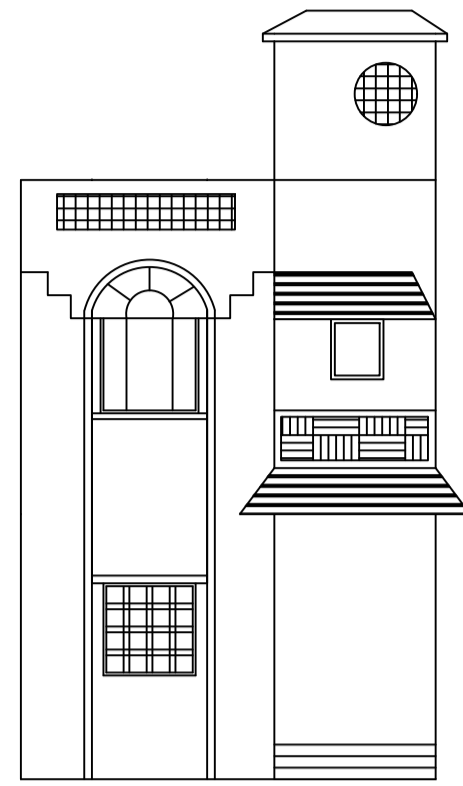

FRONT ELEVATION

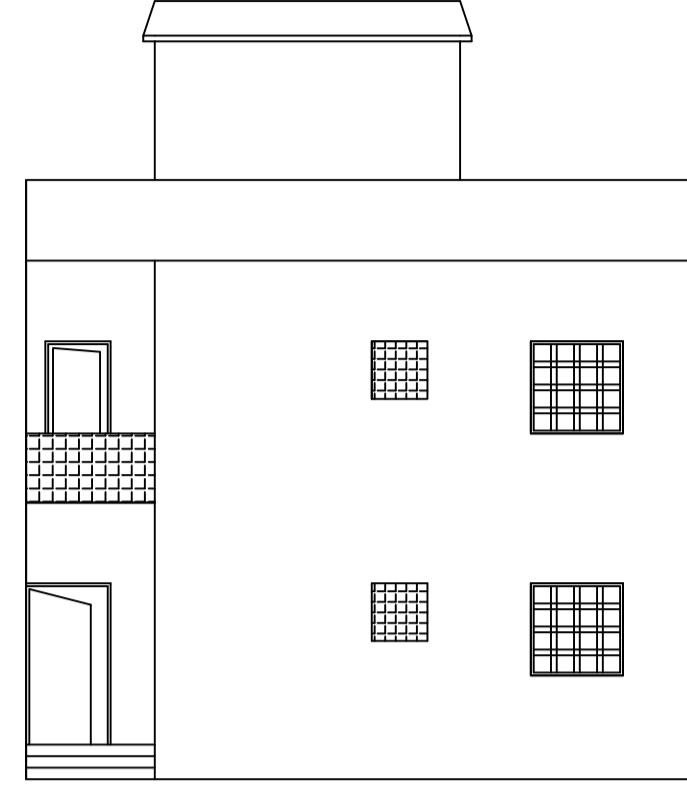

RIGHT SIDE ELEVATION

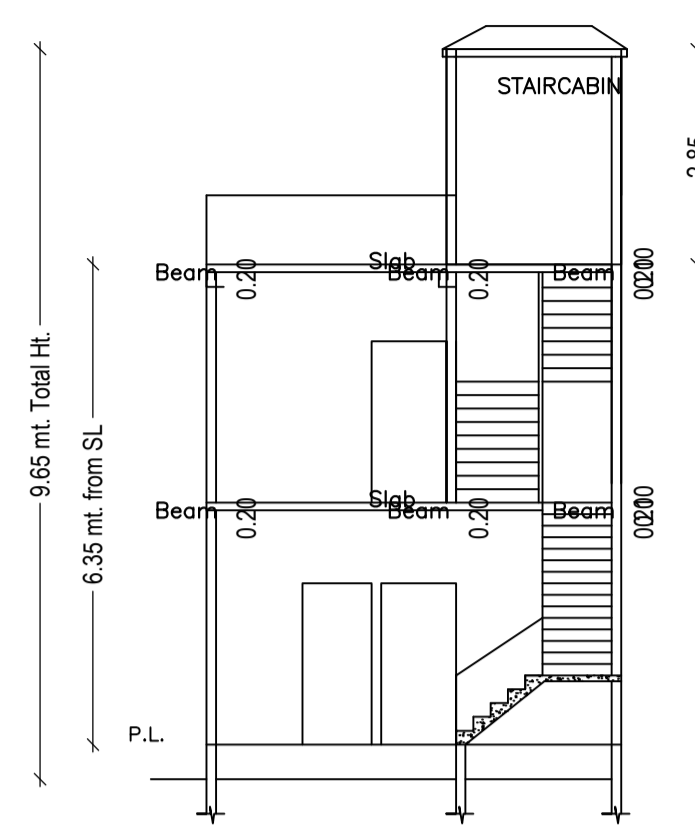

SECTION AT- X:X

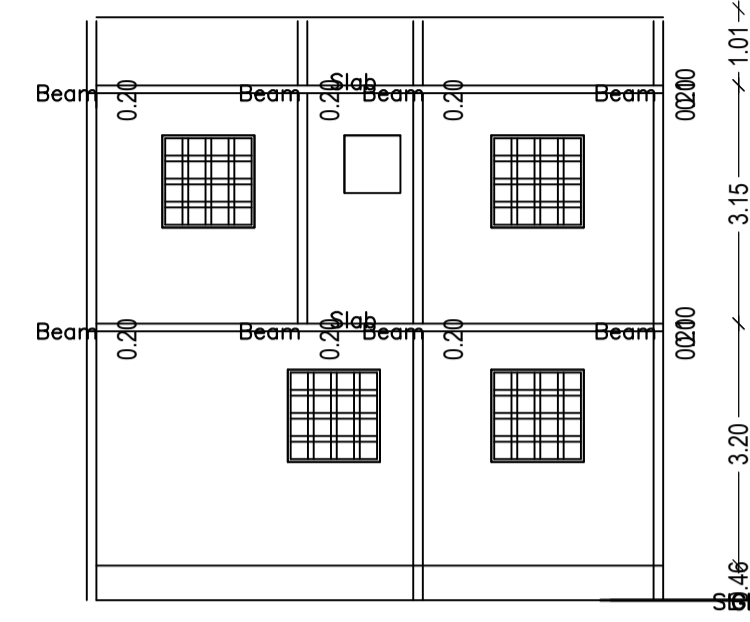

SECTION AT- Y:Y

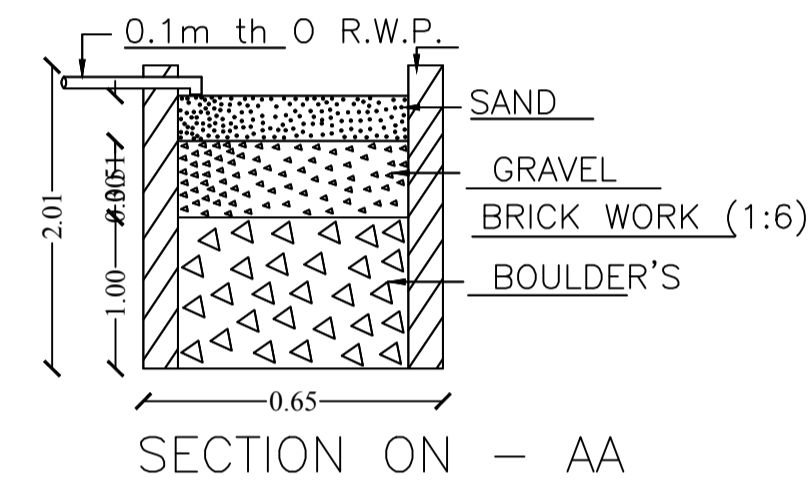
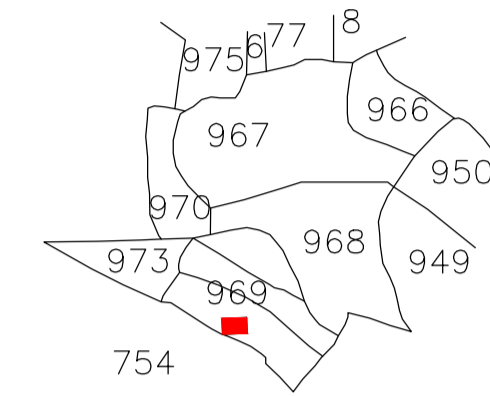

SECTION ON - AA

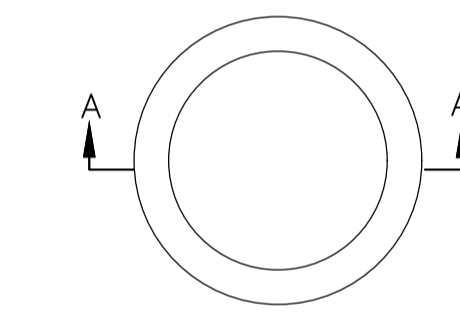

DETAIL'S OF WATER HARVESTING

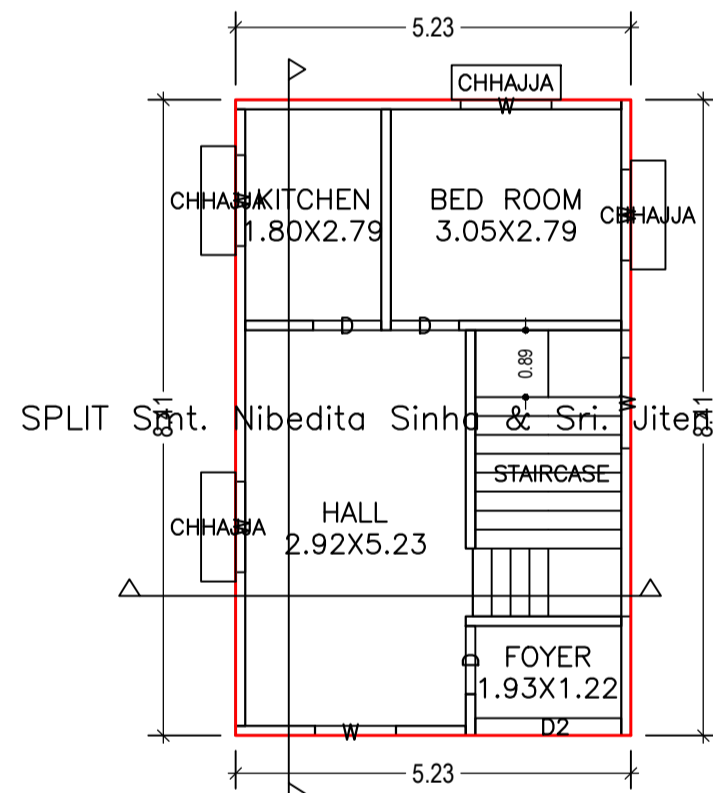
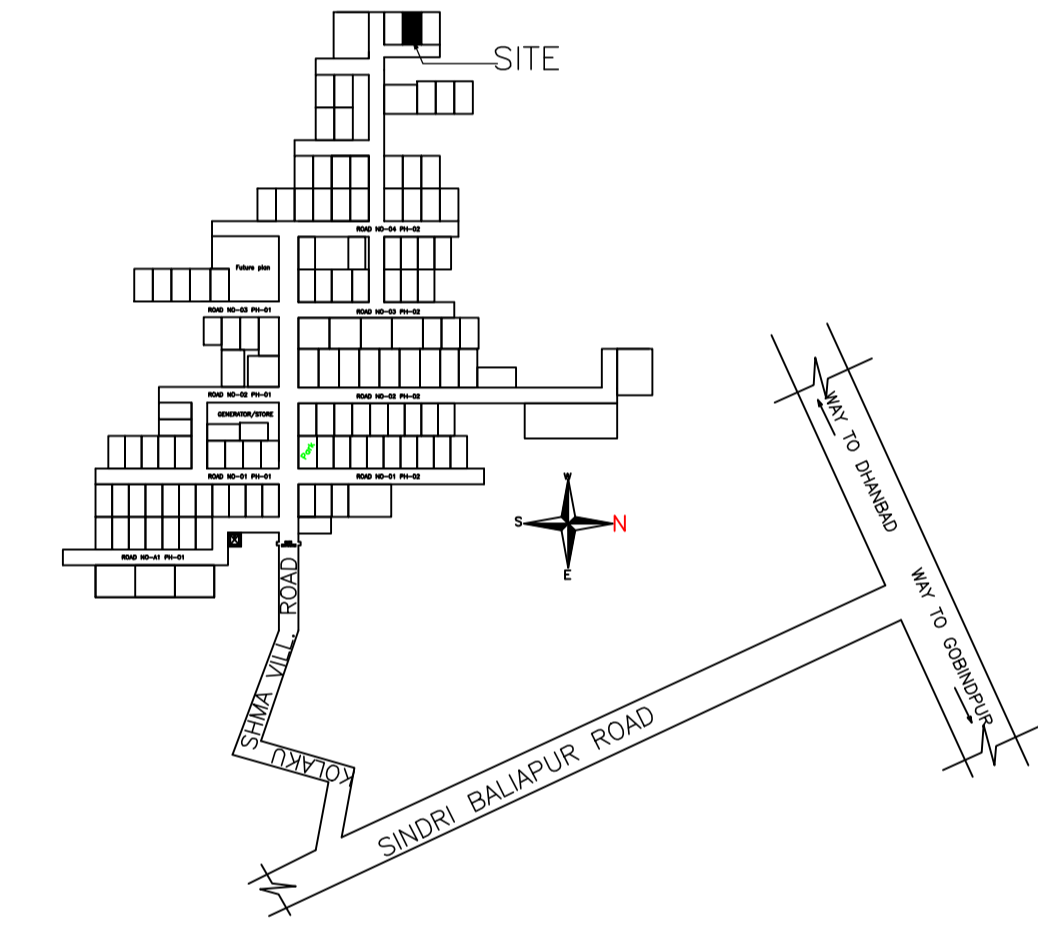

GROUND FLOOR PLAN (Proposed) (SCALE 1:100)

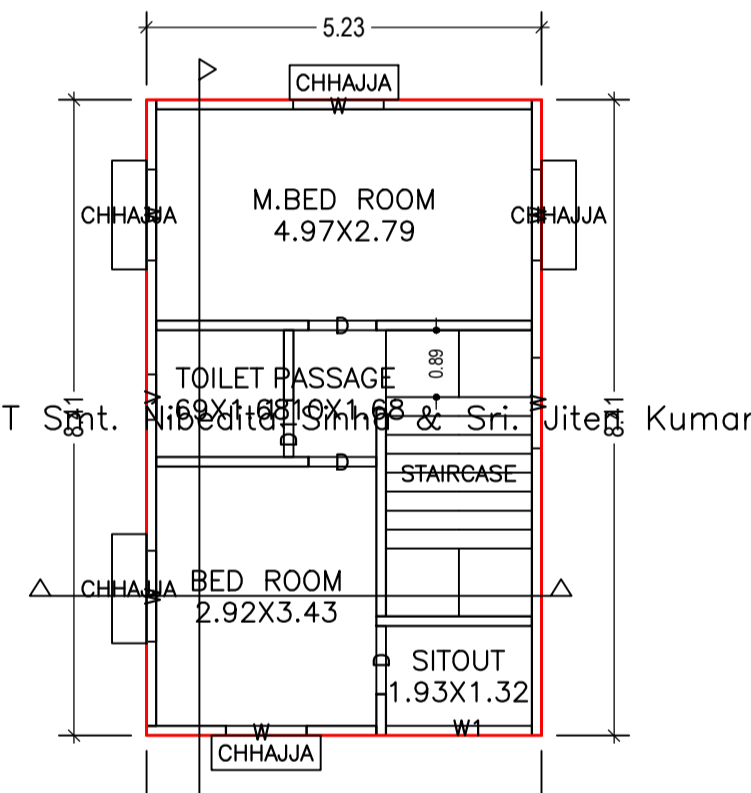

FIRST FLOOR PLAN (Proposed) (SCALE 1:100)

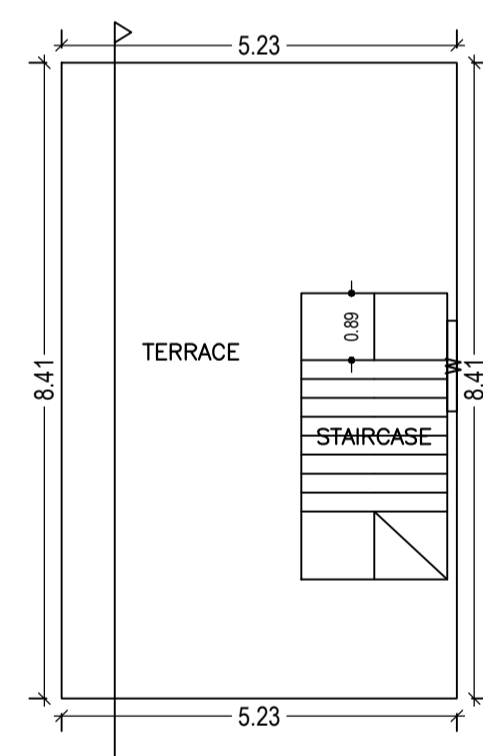

TERRACE FLOOR PLAN (SCALE 1:100)

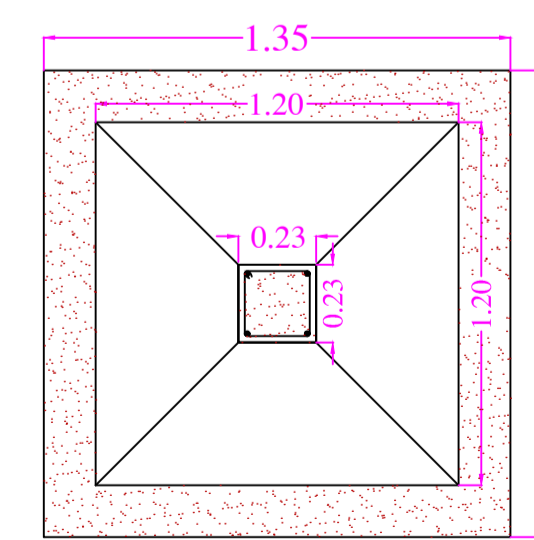

FOUNDATION PLAN

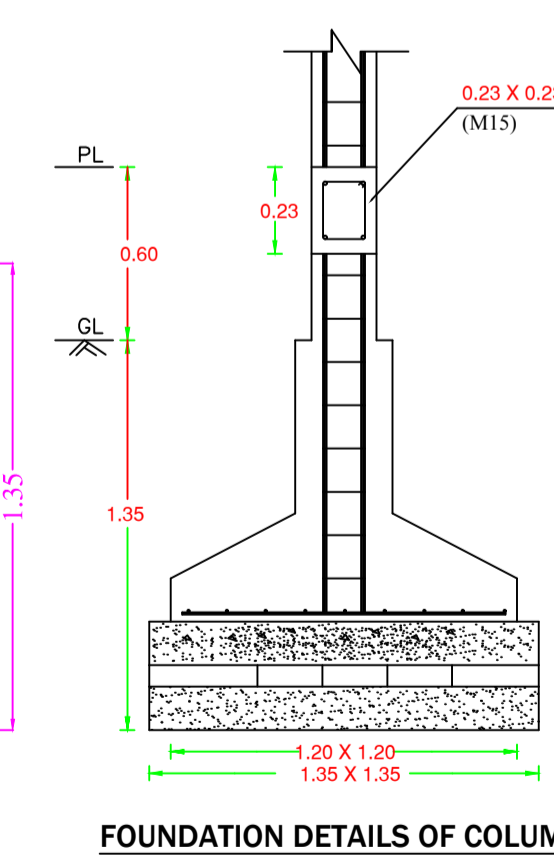

FOUNDATION DETAILS OF COLUMN

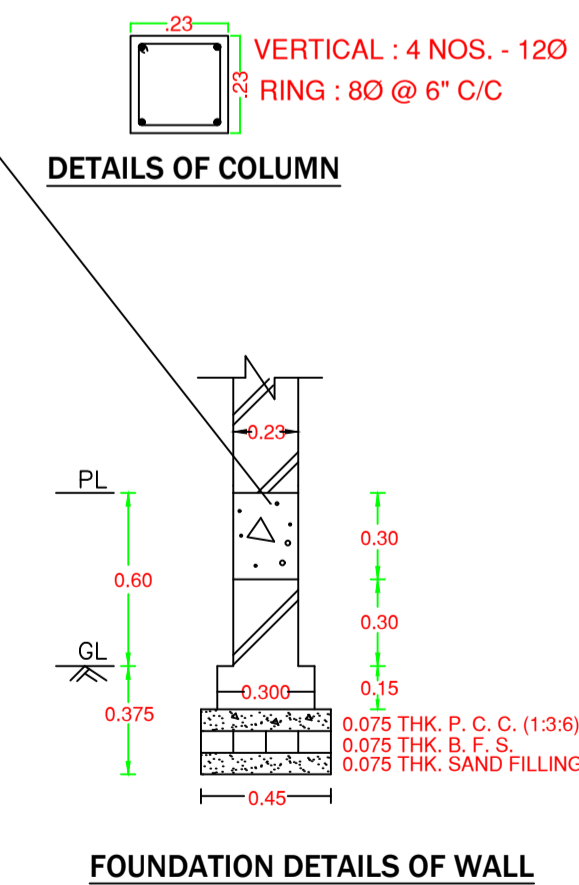

FOUNDATION DETAILS OF WALL

LTP NAME AND SIGNATURE	STRUCTURAL ENG'S NAME AND SIGNATURE	BUILDER NAME AND SIGNATURE	DIGITAL SIGNATURE
Kumud Kanchan DMC/ARC/0002/2016			