

Project Title - SMT. SOMIA CHOURASIA

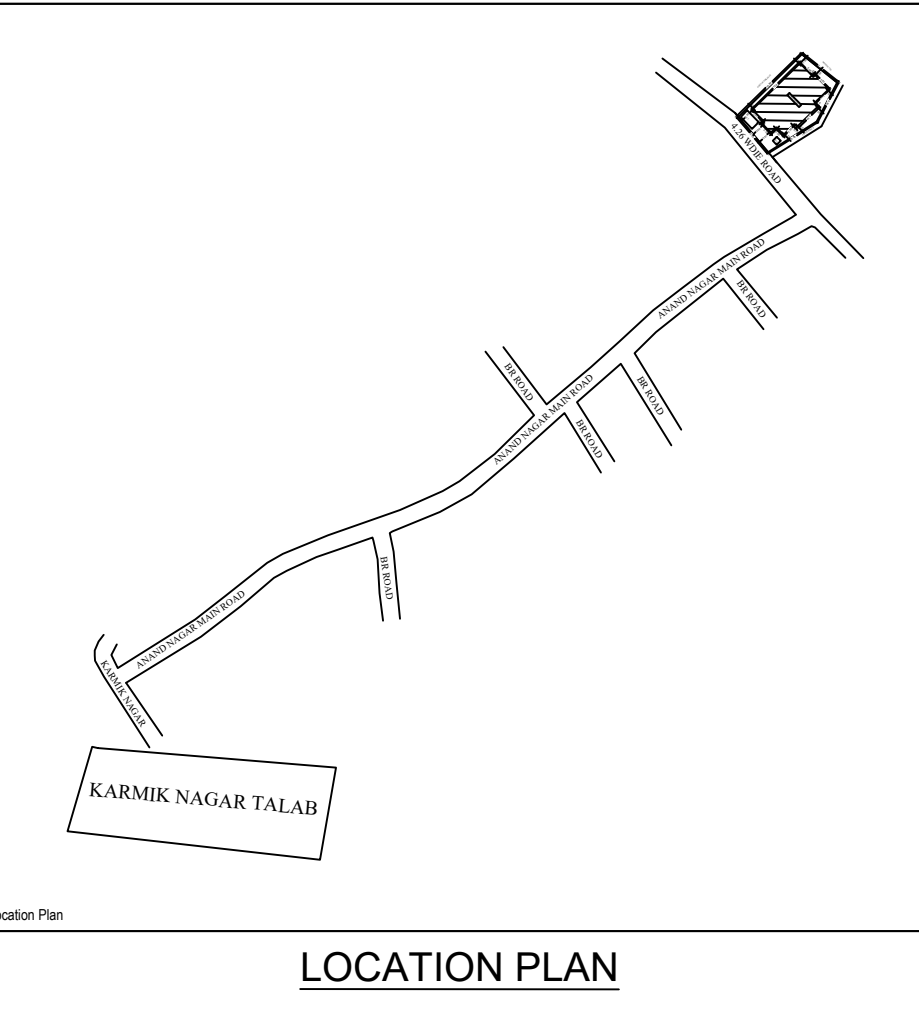
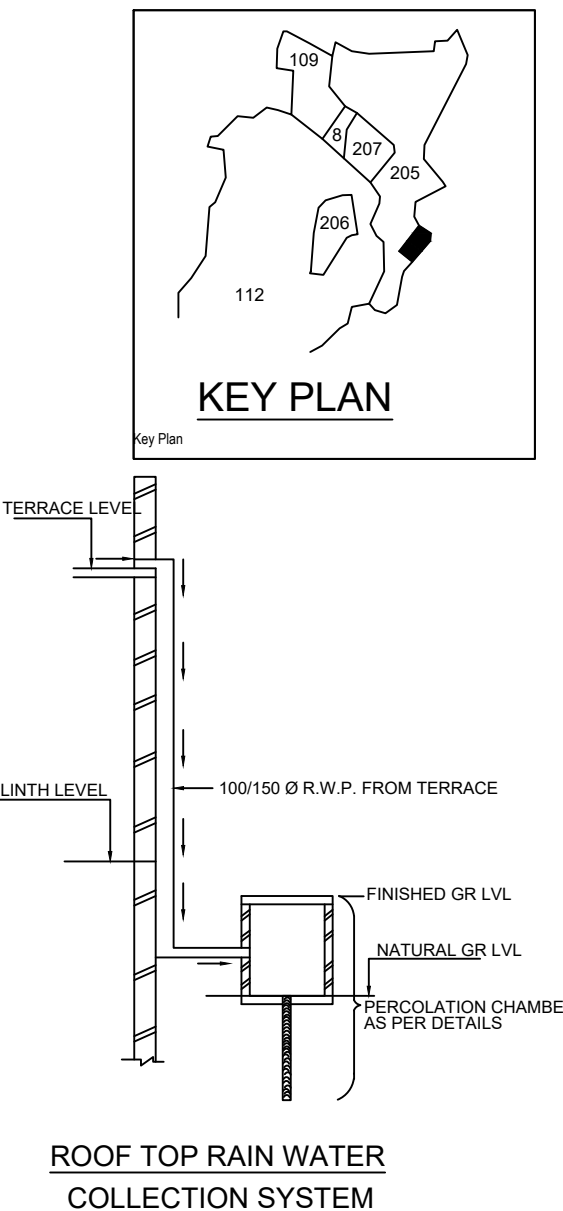
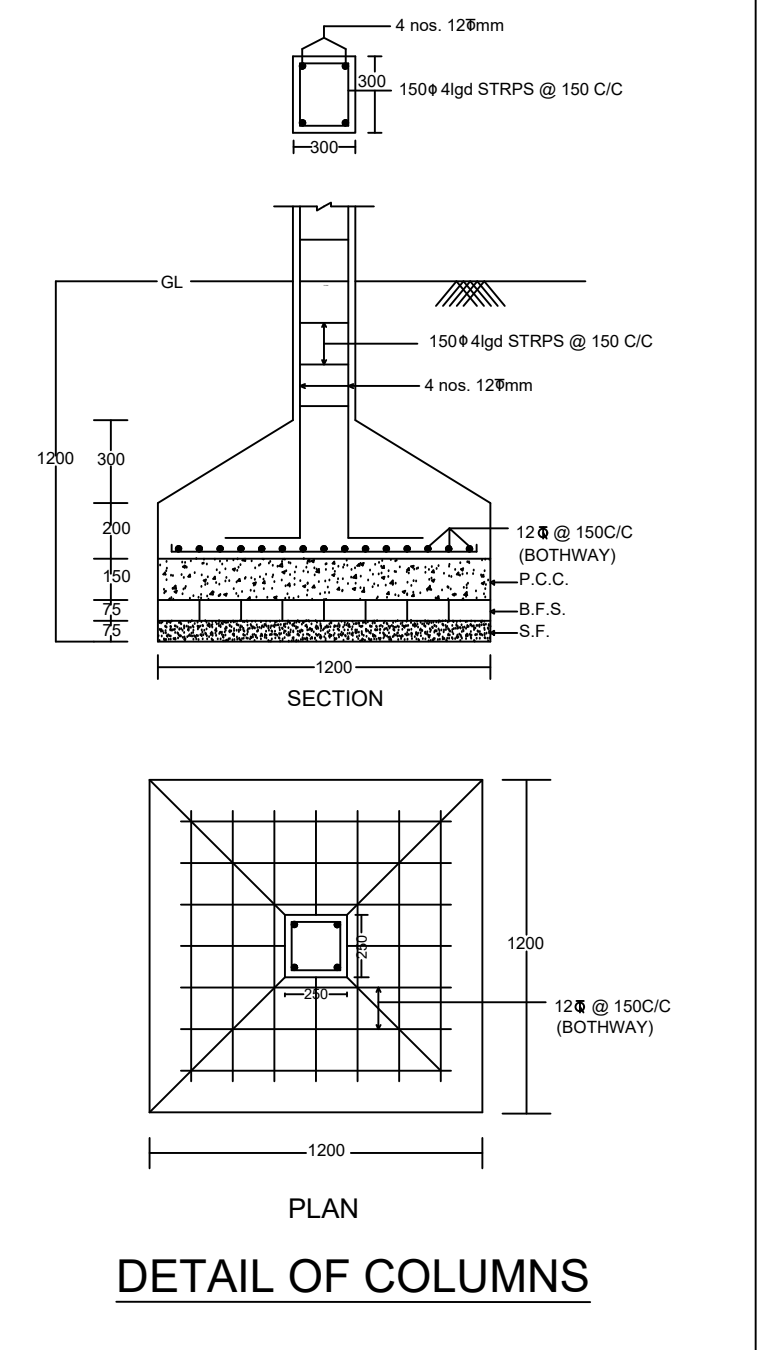
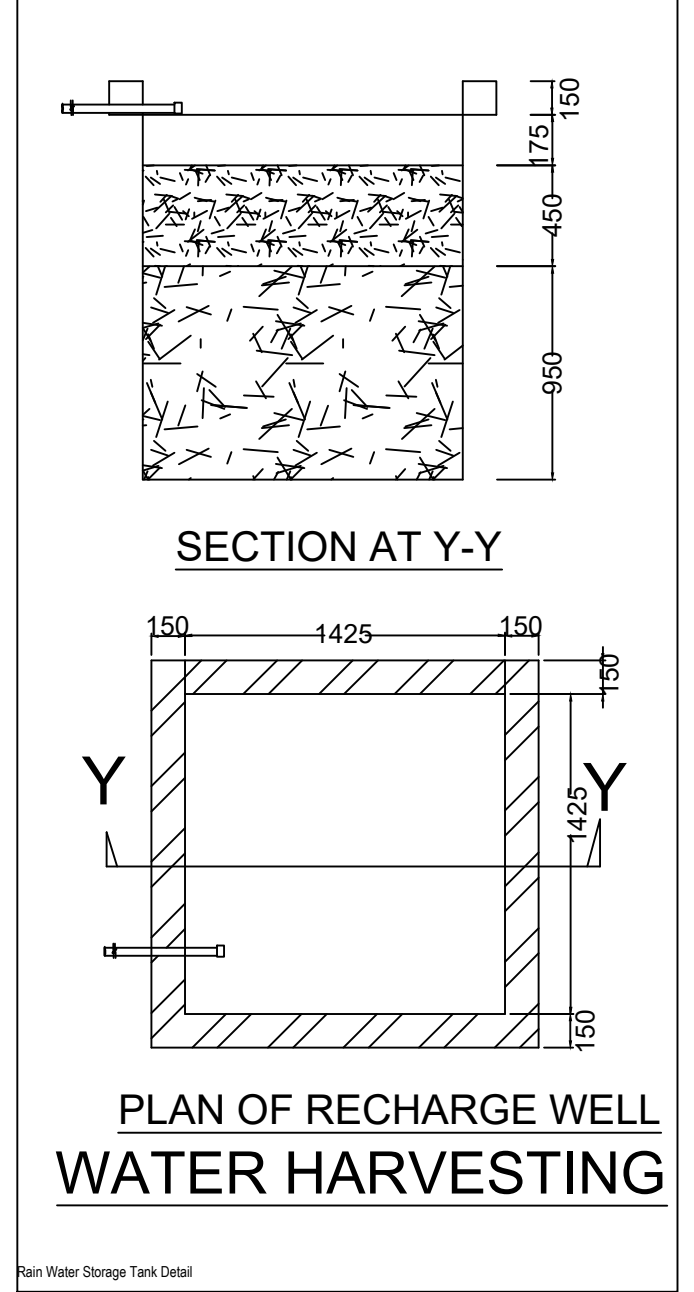
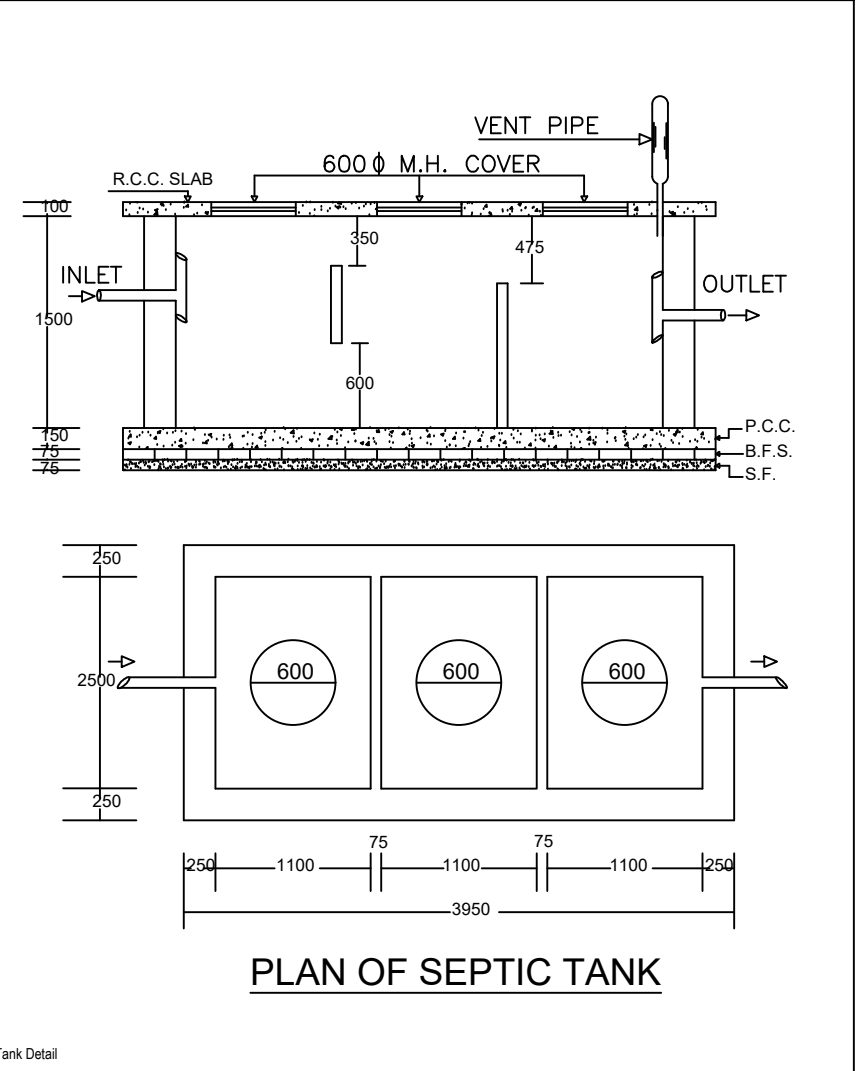
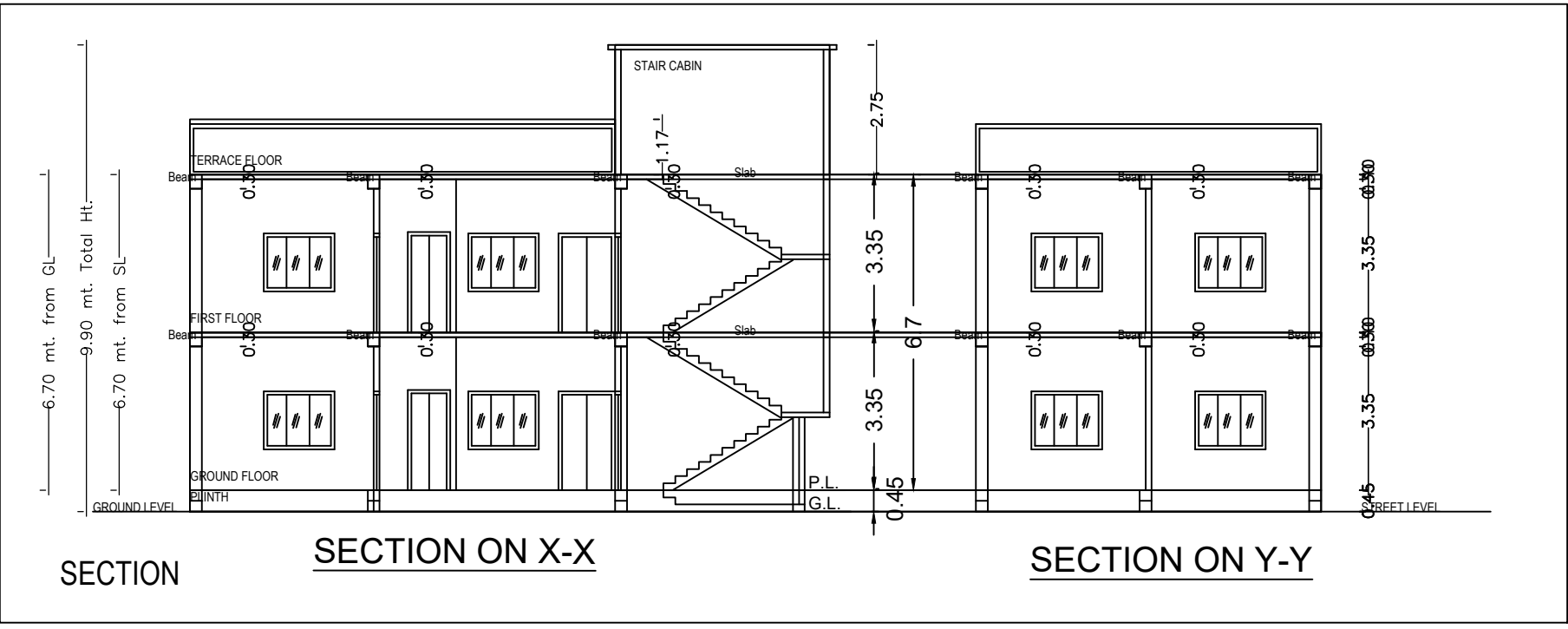
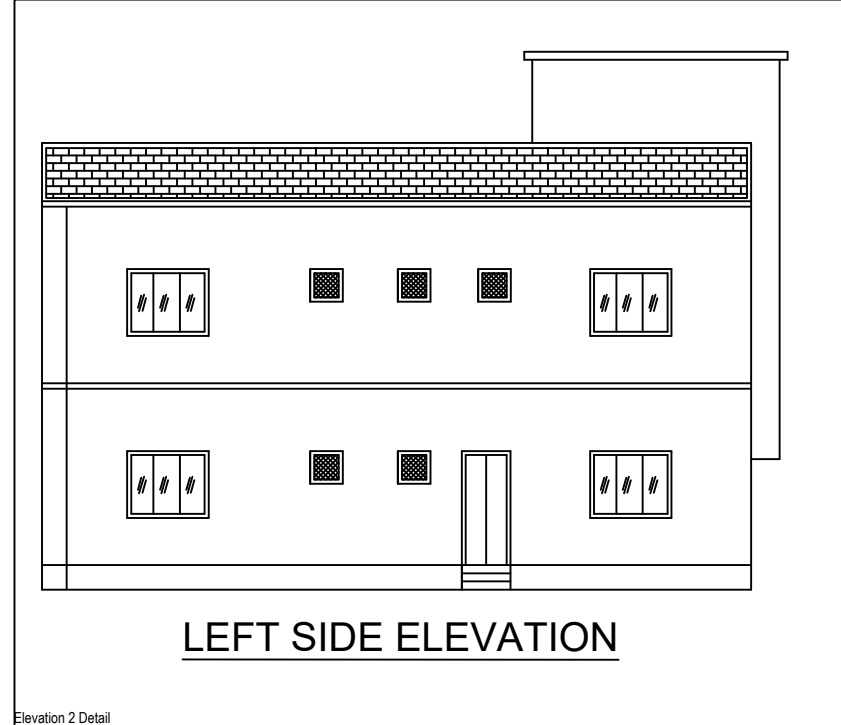
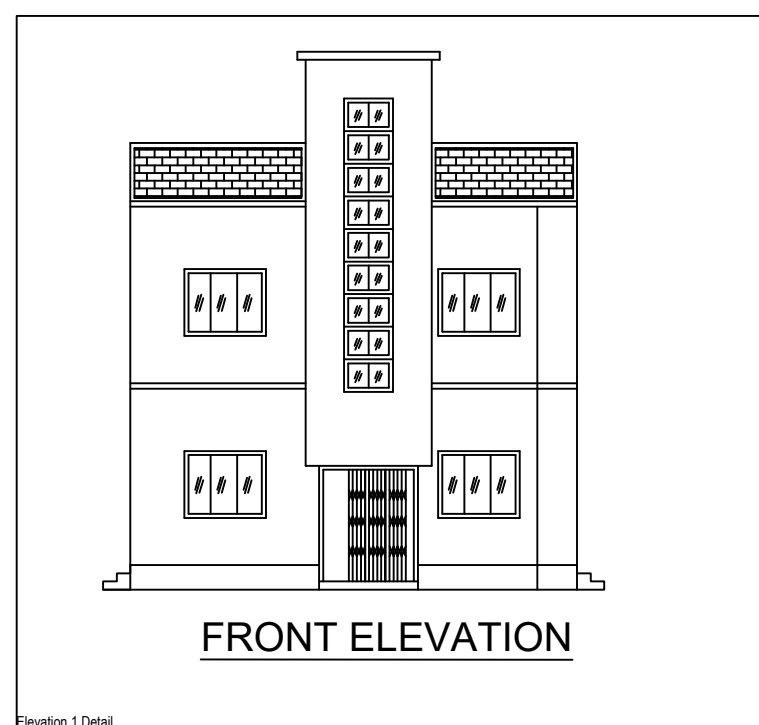

BRIEF SPECIFICATION
 FOUNDATION----- CEMENT CONCRETE (1:1.5:3)
 BRICK WORK IN FOUNDATION & SUPERSTRUCTURE
 FIRST CLASS BRICK WORK IN CEMENT MORTAR (1:2:4)
 D.P.C.-----25 D.P.C. IN CEMENT CONCRETE (1:2:4)
 FLOOR-----25 I.P.S. OVER 75 P.C.C.
 ROOF-----100 THK. R.C.C. ROOF (1:1.5:3)
 LINTEL-----150 THK. R.C.C. LINTEL (1:1.5:3)
 STAIRS-----RISE-- 150, TREAD-- 250

DETAILS OF AREA
 TOTAL AREA (AS PER DEED)----- 176.44 SQM.
 TOTAL AREA (AS PER SITE)----- 175.55 SQM.
 GROUND FLOOR AREA----- 99.07 SQM.
 FIRST FLOOR AREA----- 99.07 SQM.
 TOTAL COVERED AREA----- 198.14 SQM.
 % PLINTH AREA----- 56.43 %
 FAR----- 1.12

SCHEDULE
 D = 1.200X2.100 W1 = 1.500X1.200
 D1 = 1.050X2.100 W2 = 1.200X1.200
 D2 = 0.900X2.100 V = 0.600X0.600

TITLE OF DRAWING
 PLAN OF PROPOSED RESIDENTIAL BUILDING OF
 SMT. SOMIA CHOURASIA S/O SRI BARUN CHOURASIA
 OF HADI PARA OPPOSITE POLICE LINE DHANBAD, P.S. -
 DIST, DHANBAD, UNDER MOUZA -SARAIHELIA, NO.- 08,
 KHATA NO.- 143, NEW KHATA NO.- 490, PLOT NO.- 205
 NEW PLOT NO - 60 IN THE DISTT. OF DHANBAD
 (JHARKHAND).

SIGNATURE OF OWNER

SIGNATURE OF ENGINEER

SCALE ALL DIMENSION ARE IN METRE

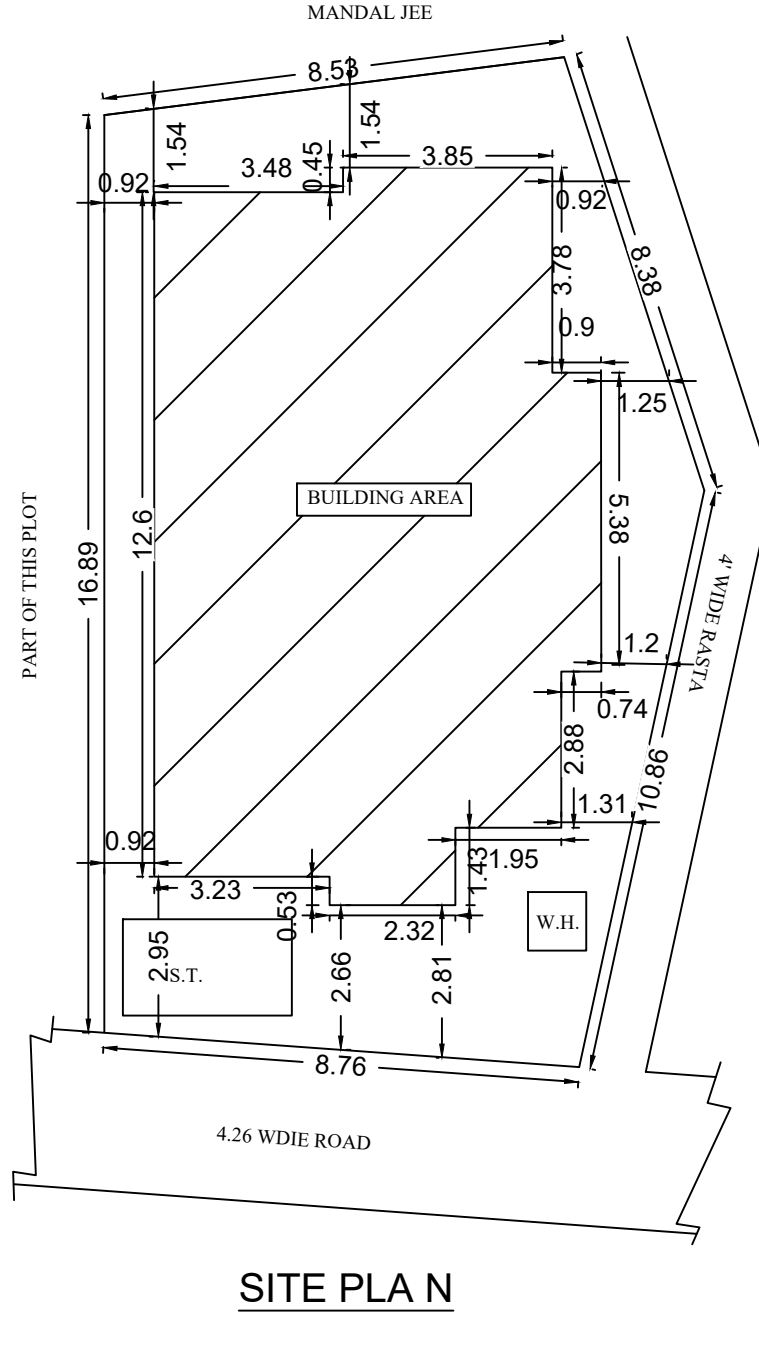
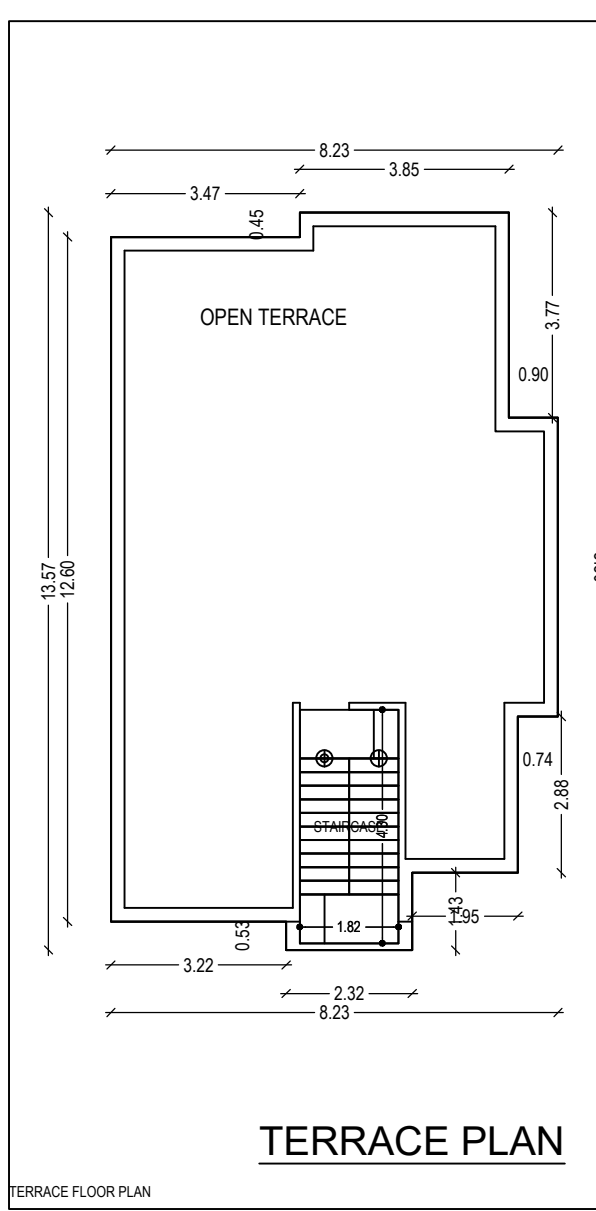
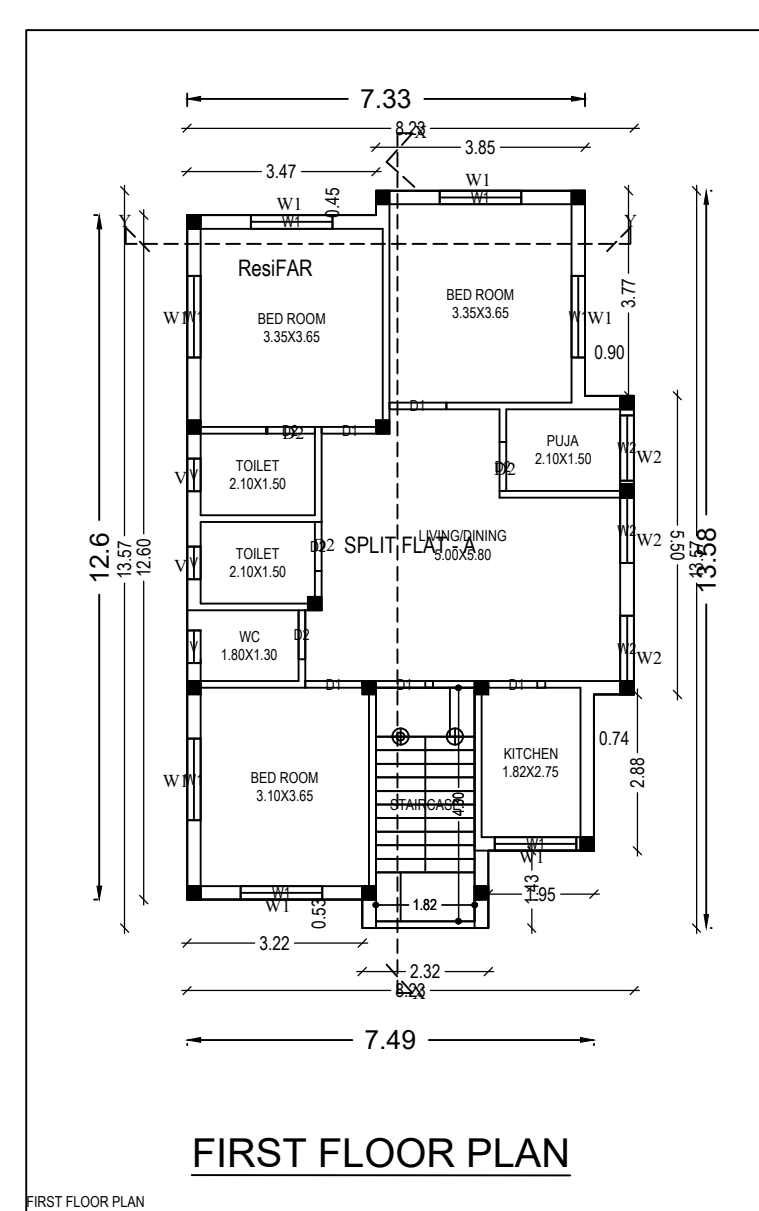
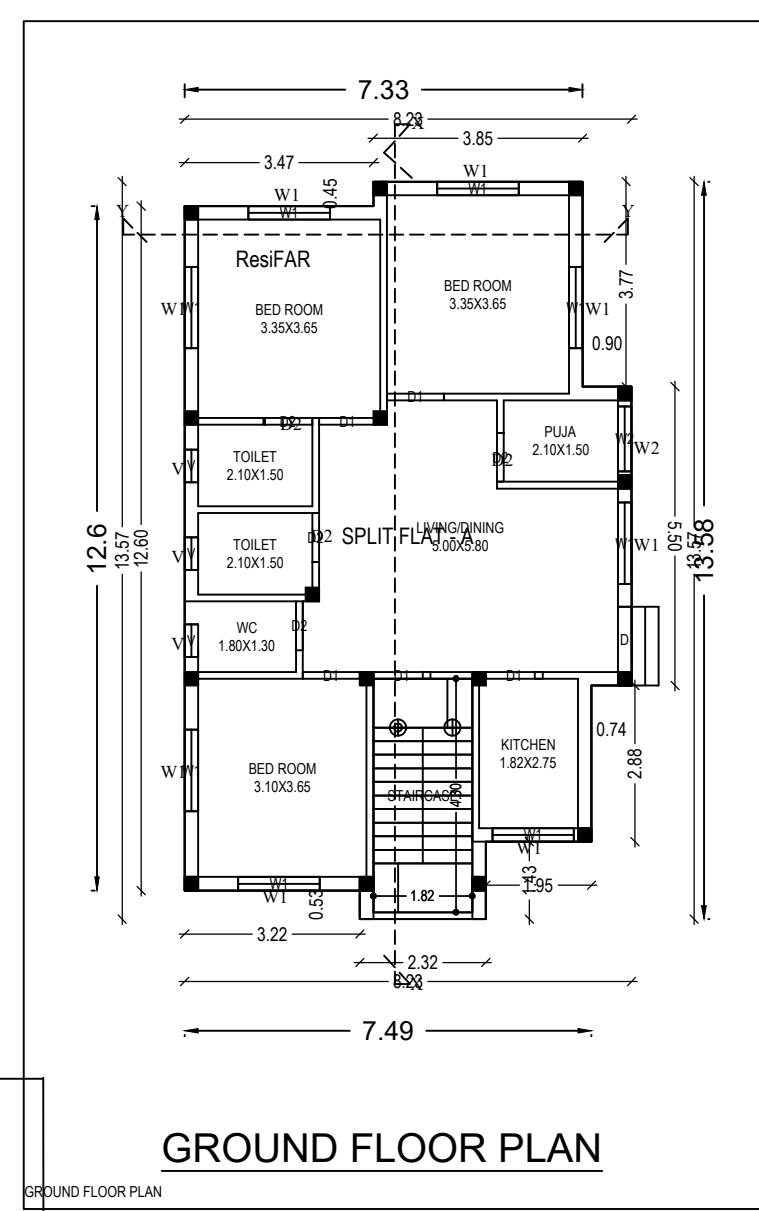
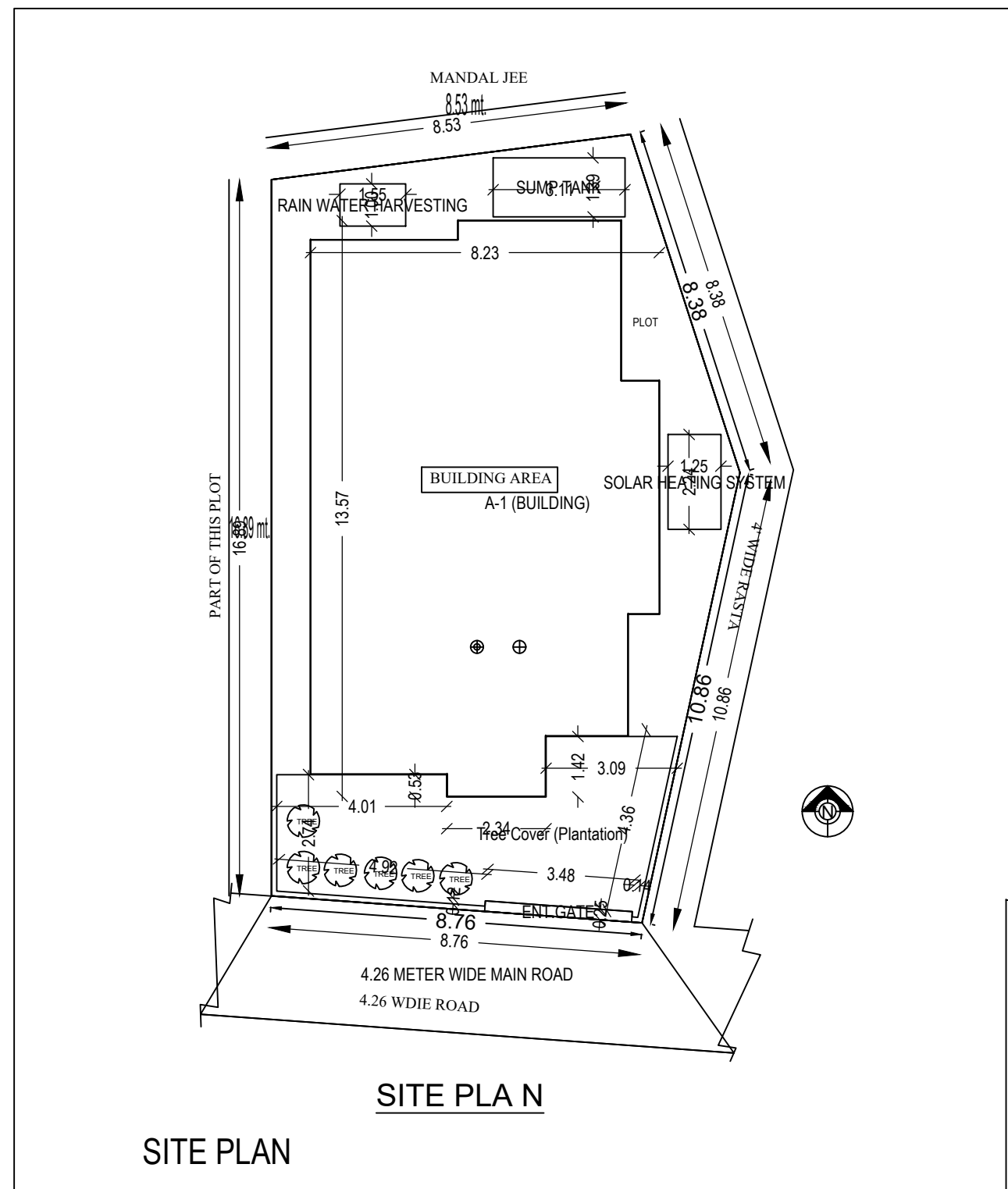

Building 'A' (BUILDING)

Floor Name	Total Built up Area (Sq.M)	Proposed FAR Area (Sq.M)	Total FAR Area (Sq.M)	Area (No.)
Ground Floor	99.08	99.08	99.08	01
First Floor	99.08	99.08	99.08	01
Terrace Floor	0.00	0.00	0.00	00
Total	198.16	198.16	198.16	02
Total Number of Same Buildings	1			
Total	198.16	198.16	198.16	02

SCHEDULE OF JOINERY

BUILDING NAME	NAME	LENGTH	HEIGHT	NO'S
A BUILDING	D	1.20	2.10	08
A BUILDING	D1	1.05	2.10	10
A BUILDING	D2	0.90	2.10	10
Total				28

SCHEDULE OF JOINERY

BUILDING NAME	NAME	LENGTH	HEIGHT	NO'S
A BUILDING	W1	1.50	1.20	08
A BUILDING	W2	1.20	1.20	04
A BUILDING	W3	1.20	1.20	04
Total				16

UNBIA Table for Building 'A' (BUILDING)

FLOOR	Name	UNBIA Type	UNBIA Area	Central Area	No. of Rooms	No. of Tenant
GROUND FLOOR PLAN	SPLIT FLAT - A	FLAT	198.08	198.08	9	1
TERRACE			0.08	0.08	0	0
Total			198.16	198.16	9	1

PROJECT DETAILS

ITEM	DESCRIPTION	UNIT	QUANTITY
Net Plot Area	Ground Floor Area	(A-Deductions)	175.55
	Deductions from Gross Plot Area		
	Deductions for Balance Plot Area (from Gross Plot Area)		
Total			175.55
Net Plot Area	Net Plot Area	(A-Deductions)	175.55
	Deductions from Gross Plot Area		
	Deductions for Balance Plot Area (from Gross Plot Area)		
Total			175.55
Proposed Coverage Area (G.F. + 1 st F)			198.14
Total Coverage Area (G.F. + 1 st F)			198.14
FAR CHECK			1.12
Proposed Area of FAR			198.14
Total Area of Plot			198.14
BUILT UP AREA CHECK			198.14
Total Proposed Built Up Area			198.14
ARCHT/ENGR/SUPERVISOR (Sign)			OWNER
			LOCAL BODY

COLOR INDEX

Color	Description
Black	Proposed Work (Coverage Area)
Grey	Existing (To be retained)
White	Existing (To be demolished)

MARGIN DETAIL

Margin	Width
Front Margin	2.64
Rear Margin	1.51
Side Margin	0.92
Side Margin	0.84

FAR & Tenement Details (Table 4c-1)

Building	No. of Same Bldg.	Total Built up Area (Sq.M)	Total FAR Area (Sq.M)	Tenement (No.)
A BUILDING	1	198.16	198.16	02
Gross Total	1	198.16	198.16	02