

Proposal Basic Information

Proposal File No.	DMC/BP/0213/W23/2019
Owner Name	Sri. Shankar Prasad Singh and Others
Khata No	43, New Khata - 602
Plot No	1858, New Plot - 2419
Village Name	Kolakusma
Use	Residential
SubUse	Bungalow/ Dwelling / Non Apartment

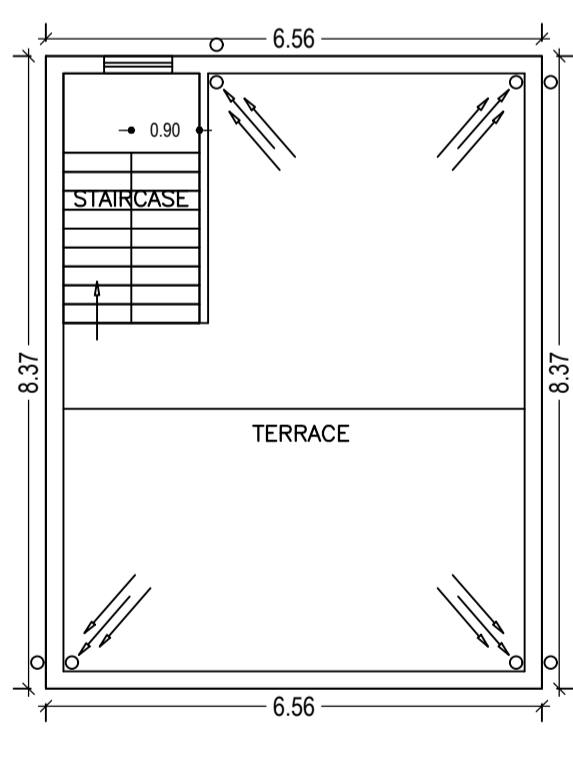
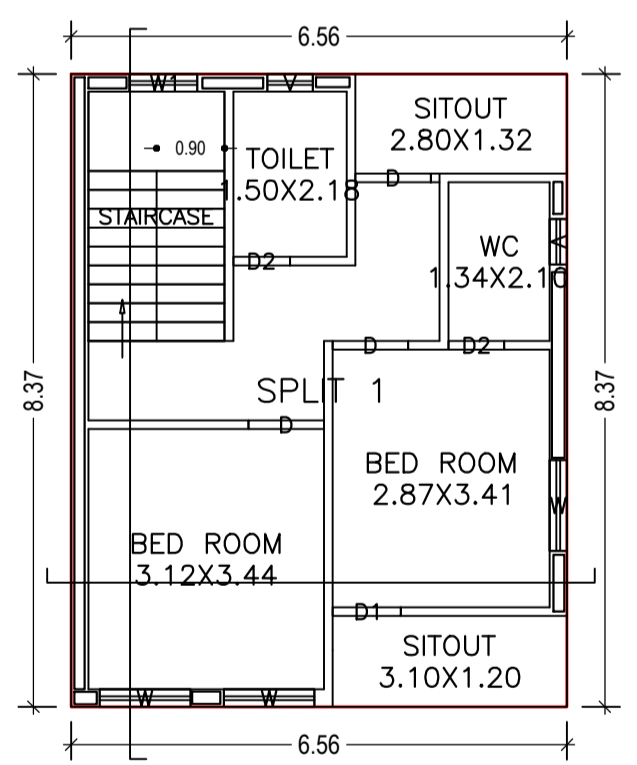
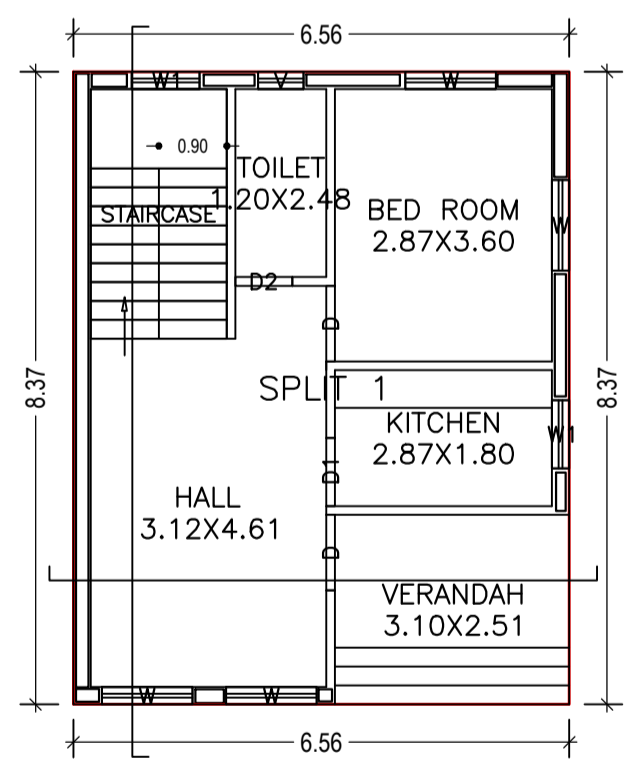
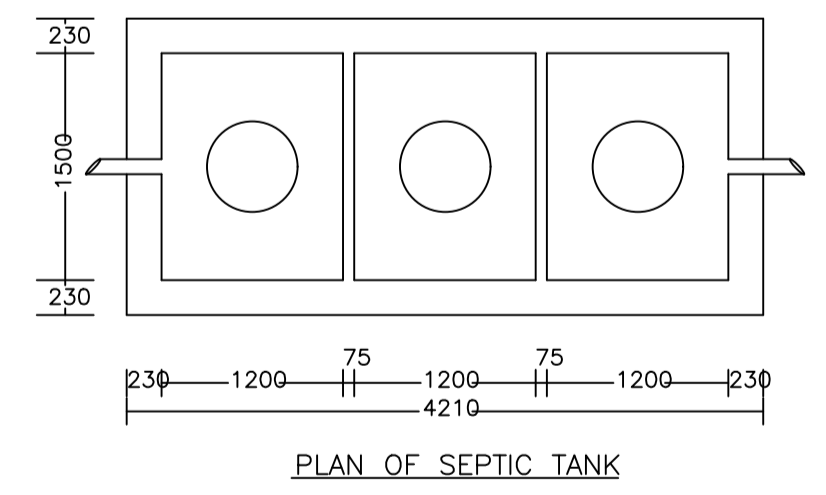
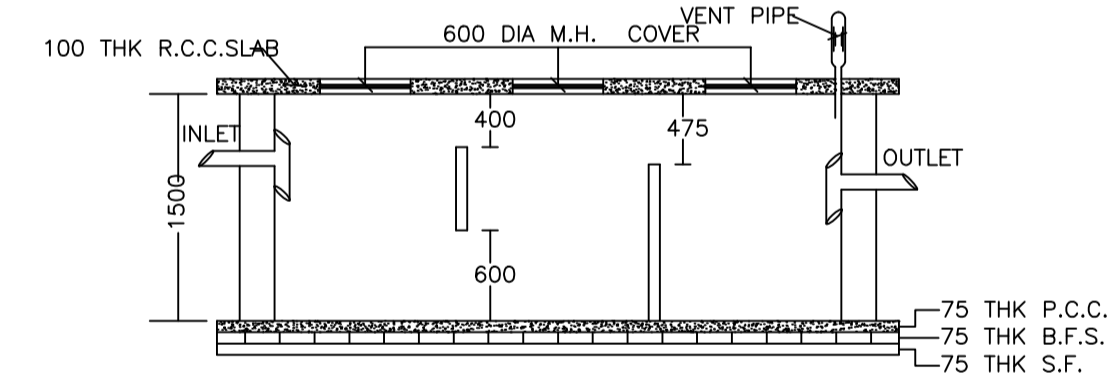
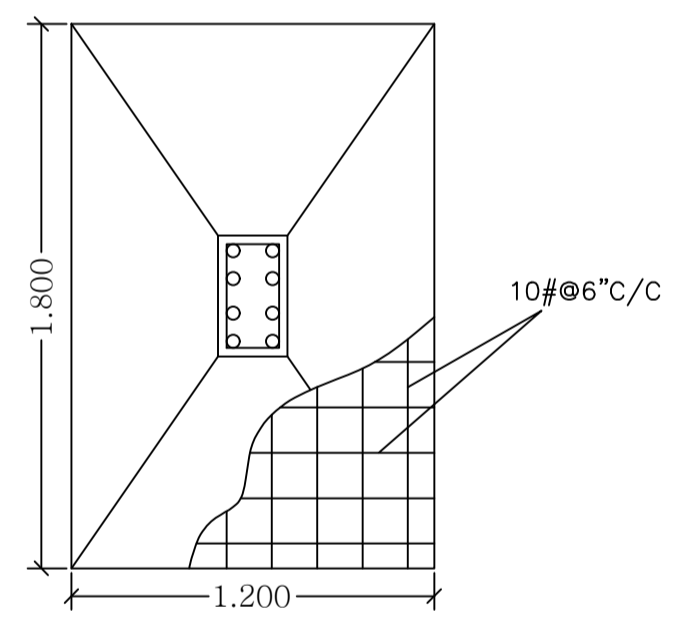
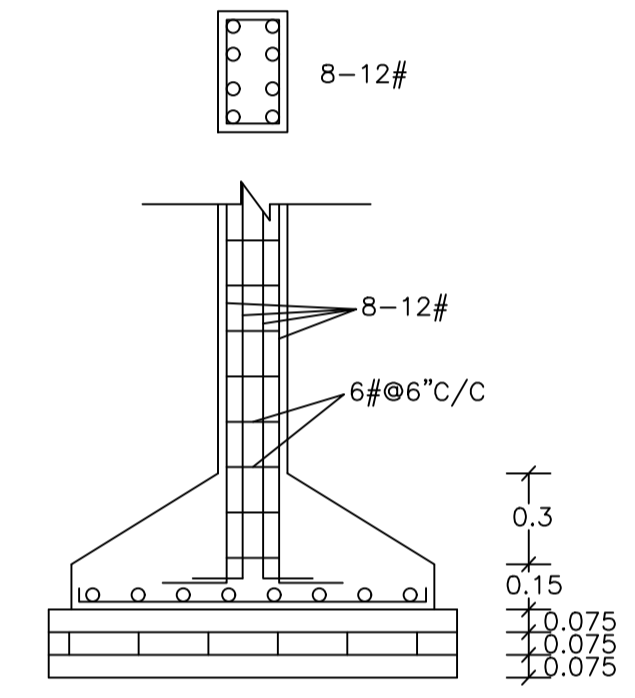
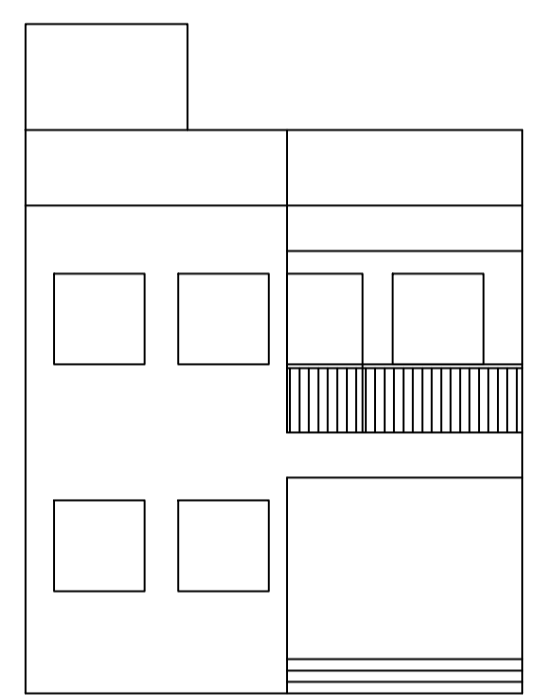
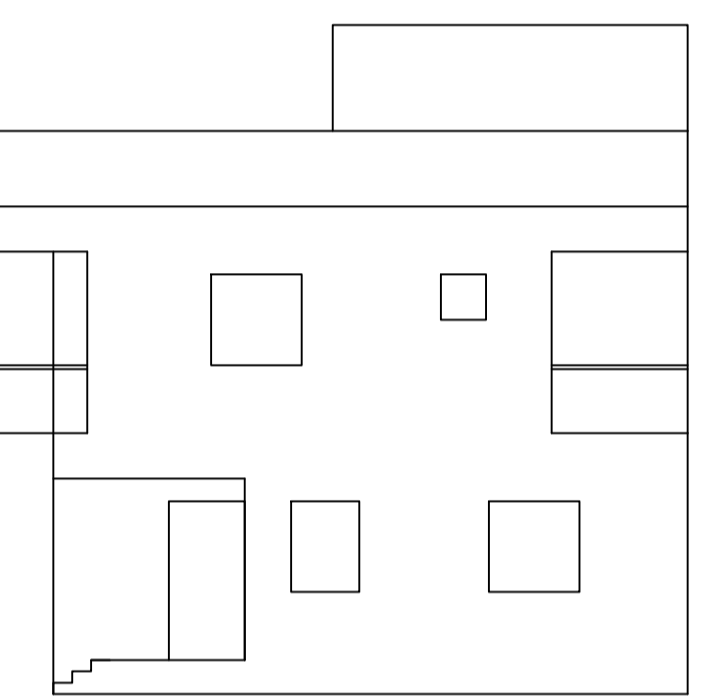
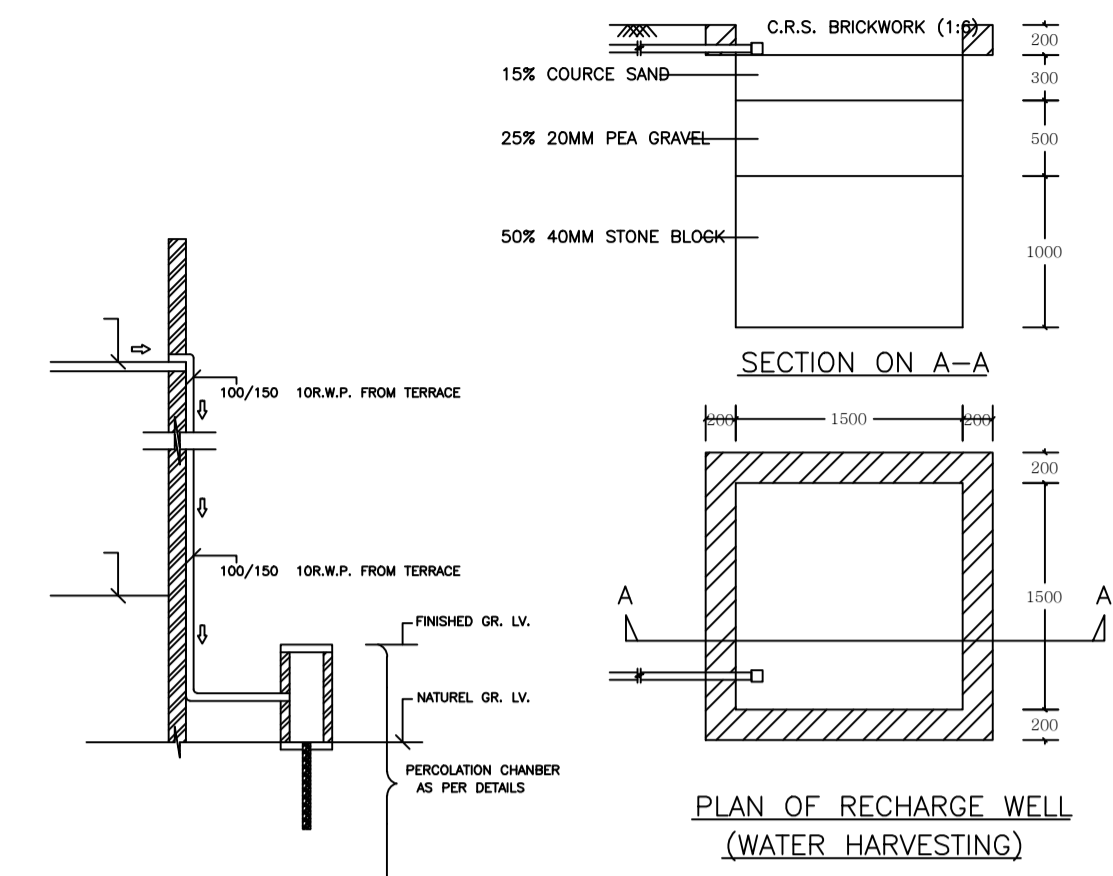
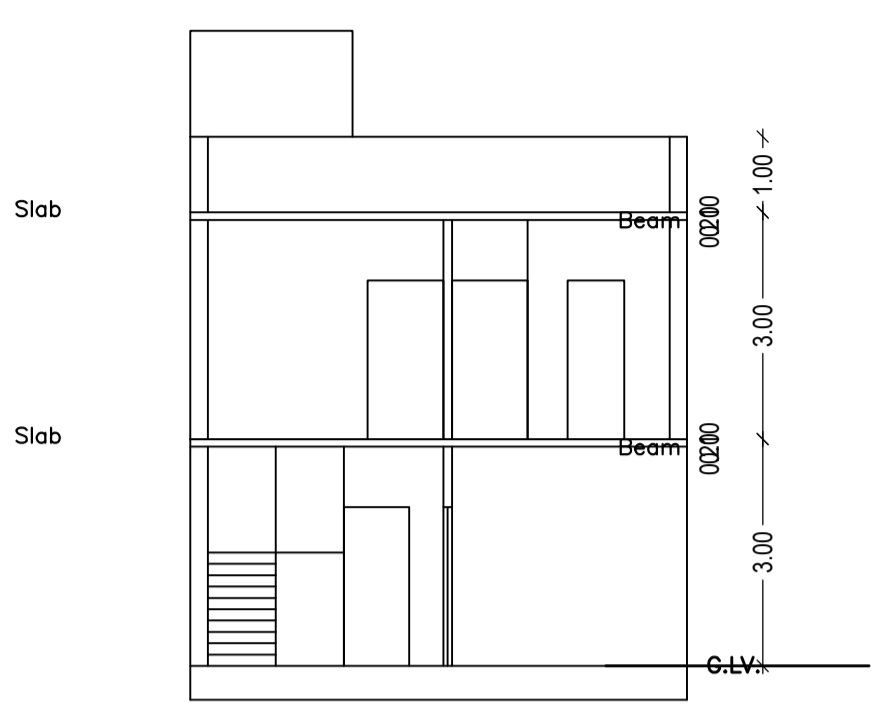
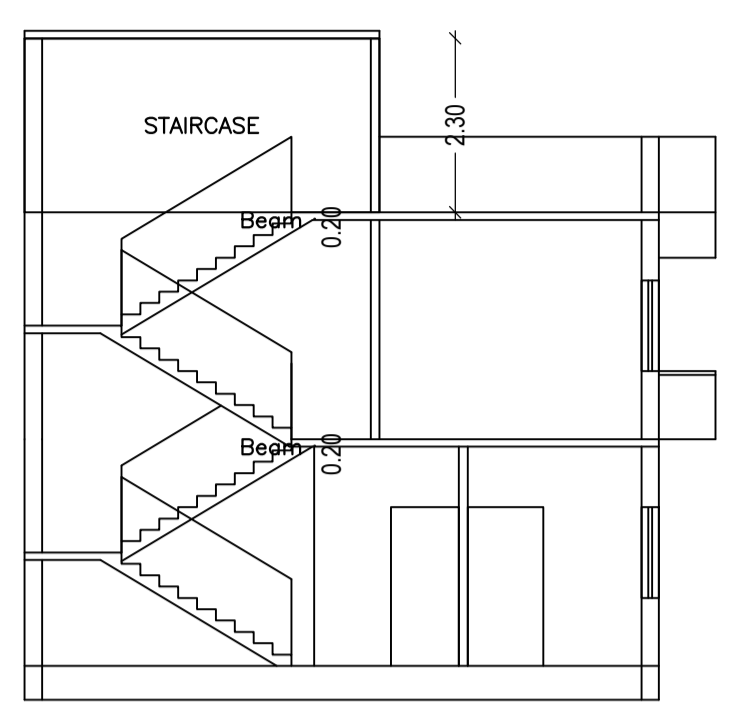
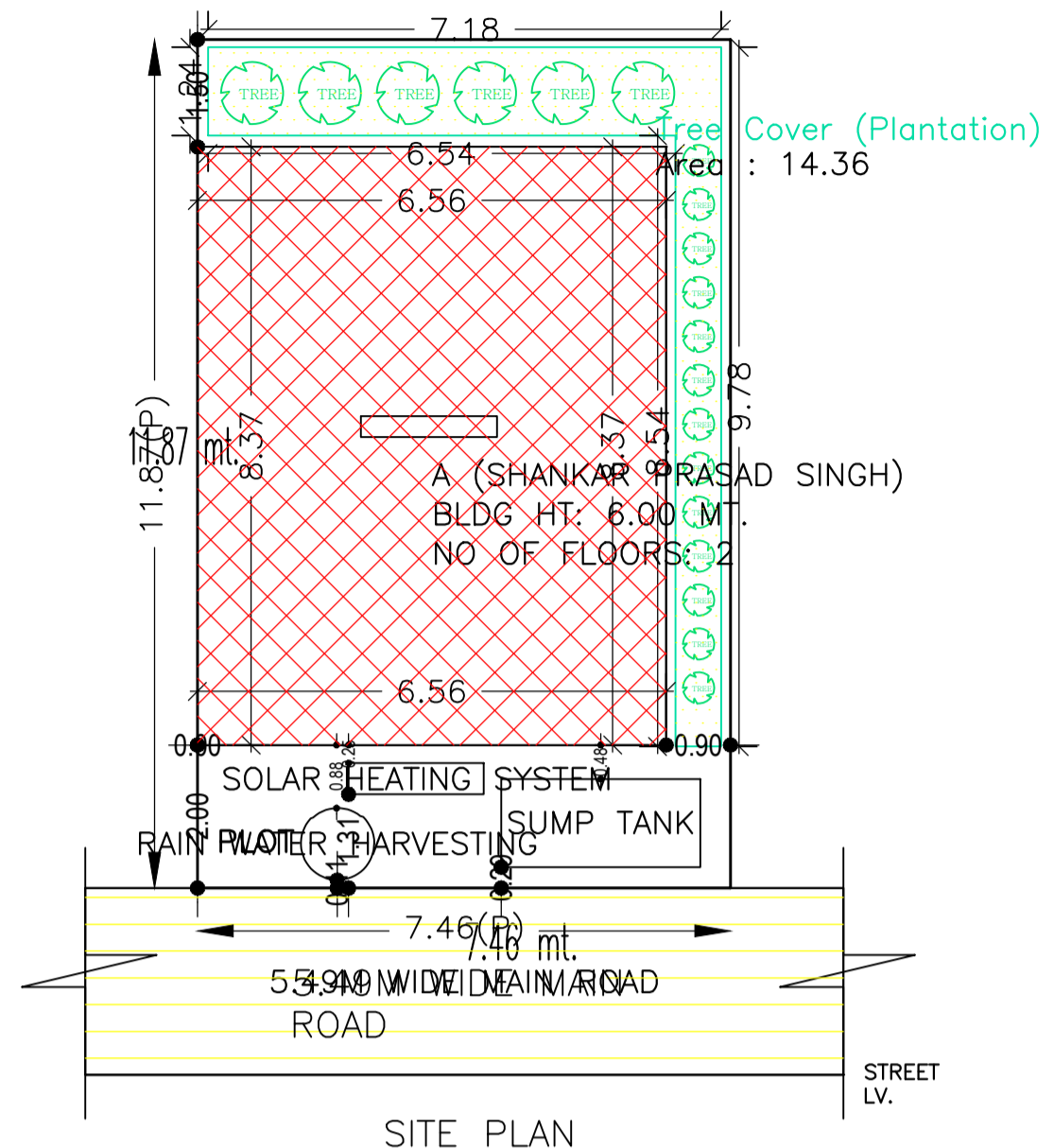

SCHEDULE OF DOOR:

BUILDING NAME	NAME	LENGTH	HEIGHT	NOS
A (SHANKAR PRASAD SINGH)	D2	0.74	2.10	01
A (SHANKAR PRASAD SINGH)	D2	0.75	2.10	02
A (SHANKAR PRASAD SINGH)	D1	0.90	2.10	02
A (SHANKAR PRASAD SINGH)	D	1.00	2.10	05

SCHEDULE OF WINDOW/VENTILATION:

BUILDING NAME	NAME	LENGTH	HEIGHT	NOS
A (SHANKAR PRASAD SINGH)	V	0.60	0.60	03
A (SHANKAR PRASAD SINGH)	W1	0.90	1.20	03
A (SHANKAR PRASAD SINGH)	W	1.20	1.20	07

Building :A (SHANKAR PRASAD SINGH)

Floor Name	Total Built Up Area (Sq.mt.)	Proposed FAR Area (Sq.mt.)	Total FAR Area (Sq.mt.)	Total Consumed Additional FAR Area (Sq.mt.)	Trmt (No.)
Ground Floor	54.89	54.89	54.89	54.89	01
First Floor	54.89	54.89	54.89	54.89	00
Terrace Floor	0.00	0.00	0.00	0.00	00
Total :	109.78	109.78	109.78	109.78	01
Total Number of Same Buildings :	1				
Total :	109.78	109.78	109.78	109.78	01

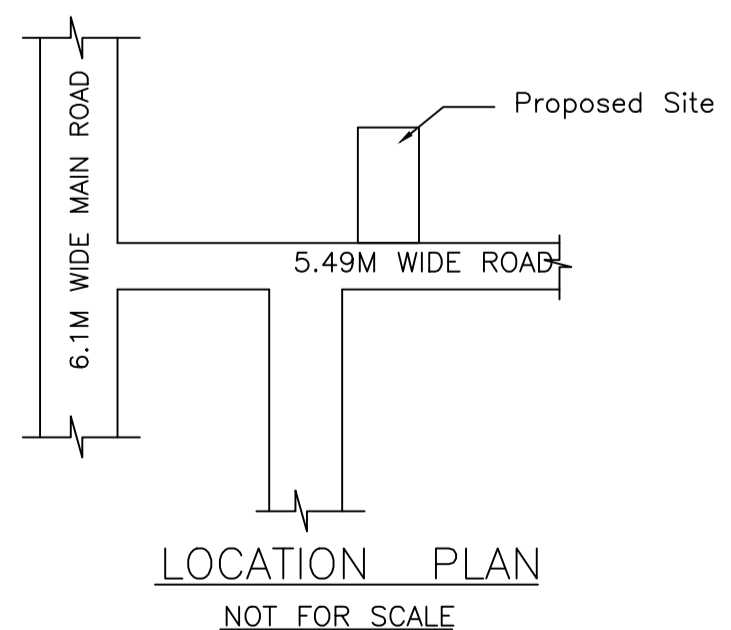
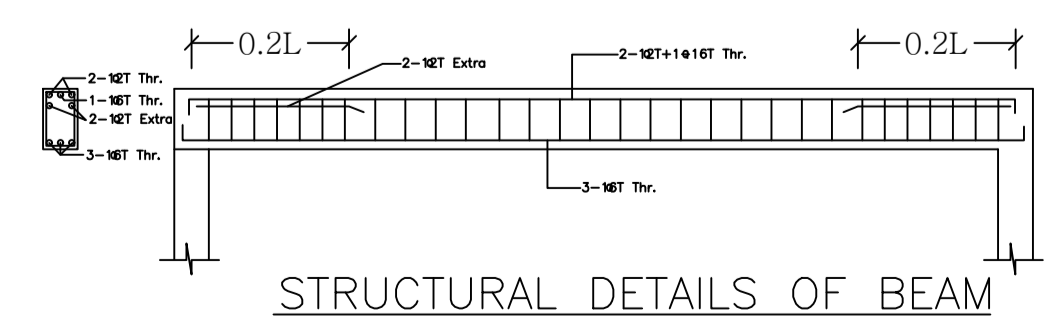

AREA STATEMENT		VERSION NO.:	1.0.38
DHANBAD MUNICIPAL CORPORATION		VERSION DATE:	29/04/2019
PROJECT DETAIL:			
Region: JHARKHAND URBAN LOCAL BODIES	Plot Use:	Residential	
District: DHANBAD	Plot SubUse:	Bungalow/ Dwelling / Non Apartment	
Authority: DHANBAD MUNICIPAL CORPORATION	Plot/Nearby/Religious/Structure:	NA	
Inward No: DMC/BP/0213/W23/2019	Plot/SubPlot No:	1858, New Plot - 2419	
Application Type: General Proposal	North: Plot No. -	POLT NO. 1859 OLD	
Project Type: Building Permission	South: Road Width -	5.49M WIDE MAIN ROAD	
Nature of Development: New	East: Plot No. -	PART OF PLOT NO. 1858 OLD	
Location of Development Area: Old Area	West: Plot No. -	PART OF PLOT NO 1858 OLD	
AREA DETAILS:			
AREA OF PLOT (Minimum)	(A)	88.53	
NET AREA OF PLOT (Gross Plot Area - Deduction from Gross Plot area)	(A-Deductions)	88.53	
Deduction for Balance Plot Area (from Gross Plot Area)			
Common Plot		14.36	
Total		14.36	
BALANCE AREA OF PLOT (Net Plot Area - Recreational/Amenity spaces)	(A-Deductions)	74.17	
PLOT AREA FOR COVERAGE (Net Plot Area)	(A-Deductions)	88.53	
Plot Area for FAR (Net Plot Area + Road Widening Area)	(A-Deductions)	88.53	
COVERAGE CHECK			
Permissible Coverage area (70.00 %)		61.97	
Proposed Coverage Area (62.00 %)		54.89	
Total Prop. Coverage Area (62 %)		54.89	
Balance coverage area (8.00 %)		7.08	
FAR CHECK			
Perm. FAR Area (1.80)		159.35	
Total Perm. FAR area		159.35	
Residential FAR		109.77	
Proposed FAR Area		109.77	
Total Proposed FAR Area		109.77	
Consumed FAR (Factor)		1.24	
Balance FAR Area		49.58	
BUILT UP AREA CHECK			
Total Proposed BuiltUp Area		109.78	
ARCHITECT (Regd)			
PIYUSH KANTI SINGH			
ENGINEER (Regd)			
SUPERVISOR (Regd)			
OWNER (Regd)			
Sri. Shankar Prasad Singh and Others			
DEVELOPMENT AUTHORITY			
LOCAL BODY			

COLOR INDEX	
PLOT BOUNDARY	Black
ABUTTING ROAD	Red
PROPOSED CONSTRUCTION	Green
COMMON PLOT	Yellow
ROAD WIDENING AREA	Orange
EXISTING (To be retained)	Blue
EXISTING (To be demolished)	Light Blue

Floor Name	Building Name		Total	
	Proposed Built Up Area (Sq.mt.)	Proposed FAR Area (Sq.mt.)	Total Proposed Built Up Area (Sq.mt.)	Total FAR Area (Sq.mt.)
Ground Floor	54.89	54.89	54.89	54.89
First Floor	54.89	54.89	54.89	54.89
Terrace Floor	0.00	0.00	0.00	0.00
Total :	109.78	109.78	109.78	109.78

Building USE/SUBUSE Details

Building Name	Building Use	Building SubUse	Building Structure
A (SHANKAR PRASAD SINGH)	Residential	Bungalow/ Dwelling / Non Apartment	Non-Highrise

UnitBUA Table for Building :A (SHANKAR PRASAD SINGH)

FLOOR	Name	UnitBUA Type	UnitBUA Area	Carpet Area	No. of Rooms	No. of Tenement
GROUND FLOOR PLAN	SPLIT 1	FLAT	109.77	105.22	5	1
	SPLIT 1	FLAT	0.00	0.00	6	0
First Floor PLAN	SPLIT 1	FLAT	109.77	105.22	11	1
Total:			109.77	105.22	11	1

FAR & Tenement Details (Table 4c-1)

Building	No. of Same Bldg	Total Built Up Area (Sq.mt.)	Proposed FAR Area (Sq.mt.)	Total FAR Area (Sq.mt.)	Total Consumed Additional FAR Area (Sq.mt.)	Trmt (No.)
A (SHANKAR PRASAD SINGH)	1	109.78	109.78	109.78	109.78	01
Grand Total :	1	109.78	109.78	109.78	109.78	01

LTP NAME AND SIGNATURE	STRUCTURAL ENG'S NAME AND SIGNATURE	BUILDER NAME AND SIGNATURE	DIGITAL SIGNATURE
PIYUSH KANTI SINGH DMC/ENG/0020/2016			