

SITE PLAN

SITE PLAN

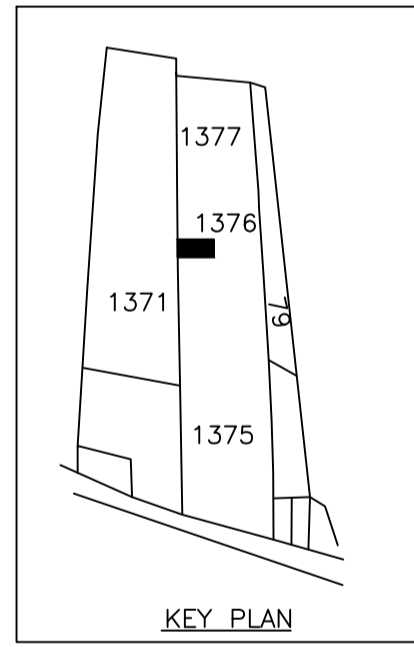

KEY PLAN

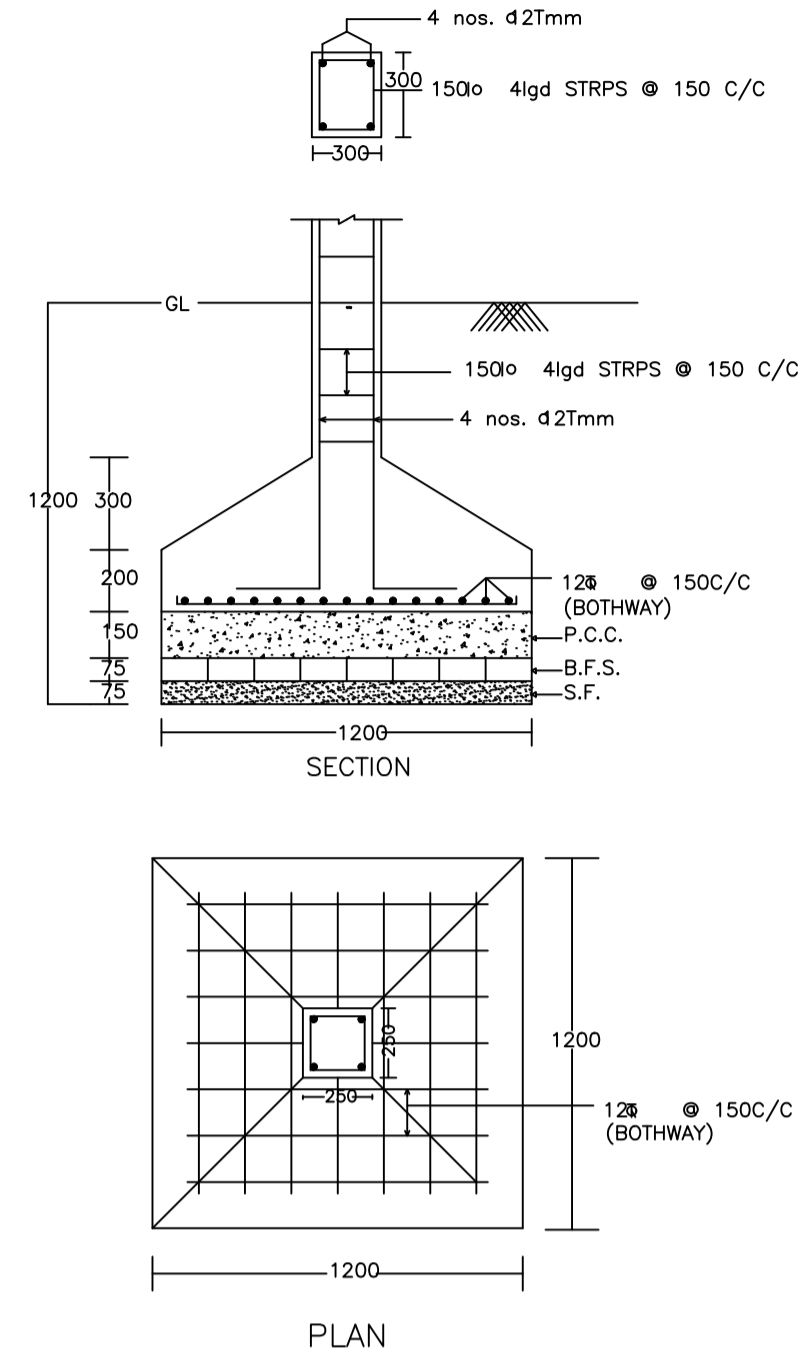

DETAIL OF COLUMNS

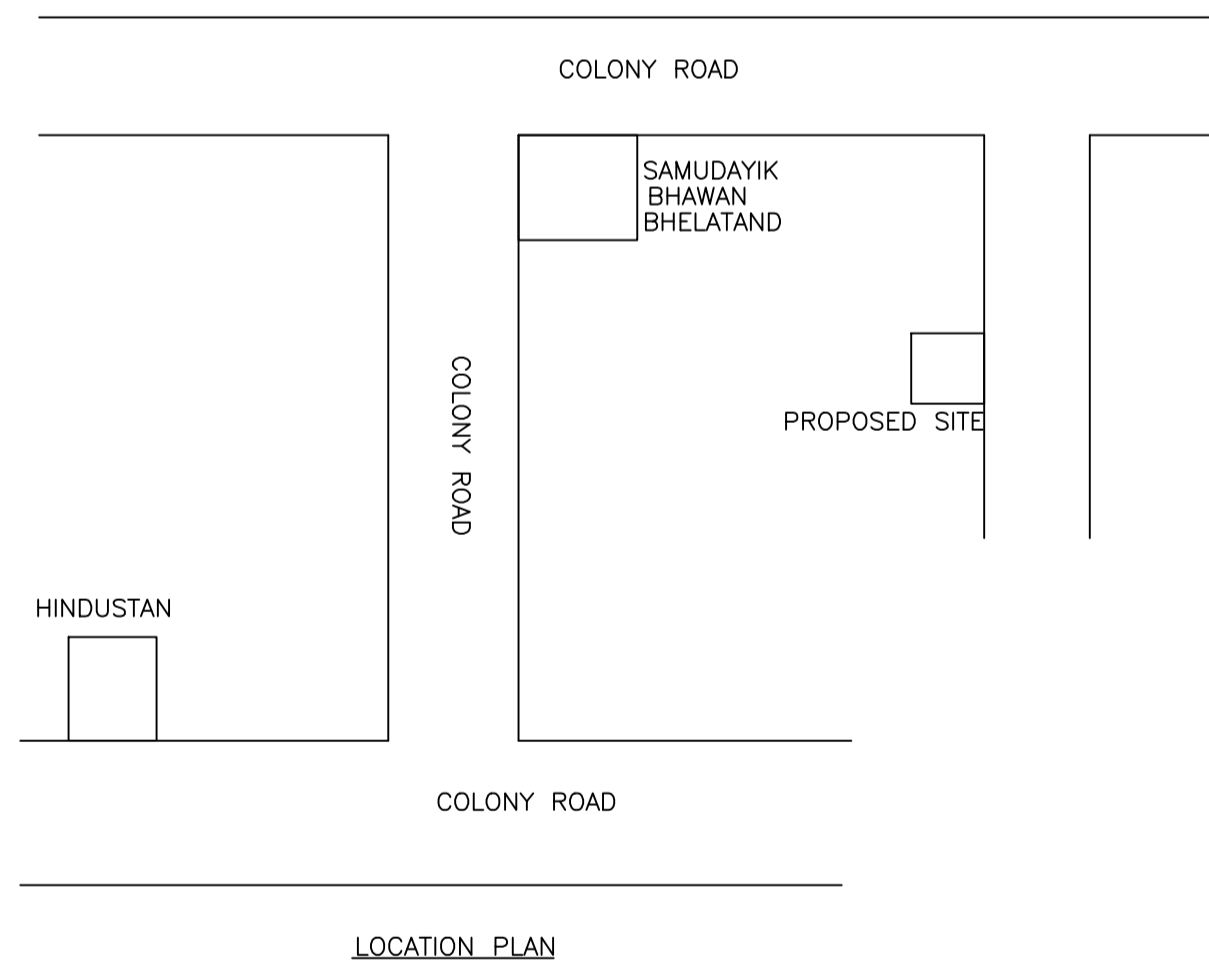

LOCATION PLAN

SCHEDULE OF DOOR:

BUILDING NAME	NAME	LENGTH	HEIGHT	NOS
A (SMT JANKI DEVI)	D	0.67	2.10	02
A (SMT JANKI DEVI)	D	0.76	2.10	02
A (SMT JANKI DEVI)	D	0.91	2.10	02
A (SMT JANKI DEVI)	D	0.92	2.10	02
A (SMT JANKI DEVI)	D	0.95	2.10	02
A (SMT JANKI DEVI)	D	1.07	2.10	02
A (SMT JANKI DEVI)	D	1.09	2.10	01
A (SMT JANKI DEVI)	D	1.19	2.10	02
A (SMT JANKI DEVI)	D	1.22	2.10	02

SCHEDULE OF WINDOW/VENTILATION:

BUILDING NAME	NAME	LENGTH	HEIGHT	NOS
A (SMT JANKI DEVI)	W	0.90	1.20	02
A (SMT JANKI DEVI)	W	0.93	1.20	02
A (SMT JANKI DEVI)	W	0.94	1.20	02
A (SMT JANKI DEVI)	W	1.04	1.20	01
A (SMT JANKI DEVI)	W	1.14	1.20	01
A (SMT JANKI DEVI)	W	1.50	1.20	17

UnitBUA Table for Building :A (SMT JANKI DEVI)

FLOOR	Name	UnitBUA Type	UnitBUA Area	Carpet Area	No. of Rooms	No. of Tenement
FIRST FLOOR PLAN	SPLIT A	FLAT	0.00	0.00	9	0
GROUND FLOOR PLAN	SPLIT A	FLAT	190.72	190.43	9	1
Total:	-	-	190.72	190.43	18	1

Building :A (SMT JANKI DEVI)

Floor Name	Total Built Up Area (Sq.mt.)	Proposed FAR Area (Sq.mt.)	Total FAR Area (Sq.mt.)	Total Consumed Additional FAR Area (Sq.mt.)	Tnmt (No.)
Ground Floor	95.36	95.36	95.36	95.36	01
First Floor	95.36	95.36	95.36	95.36	00
Terrace Floor	0.00	0.00	0.00	0.00	00
Total :	190.72	190.72	190.72	190.72	01
Total Number of Same Buildings	1				
Total :	190.72	190.72	190.72	190.72	01

FAR & Tenement Details (Table 4c-1)

Building	No. of Same Bldg	Total Built Up Area (Sq.mt.)	Proposed FAR Area (Sq.mt.)	Total FAR Area (Sq.mt.)	Total Consumed Additional FAR Area (Sq.mt.)	Tnmt (No.)
A (SMT JANKI DEVI)	1	190.72	190.72	190.72	190.72	01
Grand Total:	1	190.72	190.72	190.72	190.72	01

Proposal Basic Information

Proposal File No.	DMC/BP/0227/W22/2019
Owner Name	SMT JANKI DEVI
Khata No	OLD-90, NEW-47
Plot No	OLD-1376, NEW-1751
Village Name	Bhelatand
Use	Residential
SubUse	Bungalow/ Dwelling / Non Apartment

AREA STATEMENT		VERSION NO. : 1.0.43
DHANBAD MUNICIPAL CORPORATION		VERSION DATE: 29/04/2019
PROJECT DETAIL:		
Region: JHARKHAND URBAN LOCAL BODIES	Plot Use: Residential	
District: DHANBAD	Plot SubUse: Bungalow/ Dwelling / Non Apartment	
Authority: DHANBAD MUNICIPAL CORPORATION	PlotNearby/ReligiousStructure: NA	
Inward No: DMC/BP/0227/W22/2019	PlotSubPlot No: OLD-1376, NEW-1751	
Application Type: General Proposal	North: Plot No. - SAPNA SINGH	
Project Type: Building Permission	South: Plot No. - RAKESH SHRIVASTA	
Nature of Development: New	East: Road Width - 3.65	
Location of Development Area: Old Area	West: Plot No. - MUNILAL HAJRA	
AREA DETAILS:		
AREA OF PLOT (Minimum)	(A)	158.77
NET AREA OF PLOT(Gross Plot Area - Deduction from Gross Plot area)	(A-Deductions)	158.77
Deduction for Balance Plot Area(from Gross Plot Area)		
Common Plot		37.15
Total		37.15
BALANCE AREA OF PLOT(Net Plot Area - Recreational/Amenity space)	(A-Deductions)	121.62
PLOT AREA FOR COVERAGE(Net Plot Area)	(A-Deductions)	158.77
Plot Area for FAR (Net Plot Area + Road Widening Area)	(A-Deductions)	158.77
COVERAGE CHECK		
Permissible Coverage area ( 70.00 % )		111.14
Proposed Coverage Area ( 60.06 % )		95.36
Total Prop. Coverage Area ( 60.06 % )		95.36
Balance coverage area ( 9.94 % )		15.78
FAR CHECK		
Perm. FAR Area ( 1.50 )		238.15
Total Perm. FAR area		238.15
Residential FAR		190.72
Proposed FAR Area		190.72
Total Proposed FAR Area		190.72
Consumed FAR (Factor)		1.20
Balance FAR Area		47.43
BUILT UP AREA CHECK		
Total Proposed BuiltUp Area		190.72
ARCHITECT (Regd)	RAJEEV RANJAN SINGH	
ENGINEER (Regd)		
SUPERVISOR (Regd)		
OWNER (Regd)	SMT JANKI DEVI	
DEVELOPMENT AUTHORITY LOCAL BODY		

COLOR INDEX	
PLOT BOUNDARY	Black
ABUTTING ROAD	Green
PROPOSED CONSTRUCTION	Red
COMMON PLOT	Yellow
ROAD WIDENING AREA	Blue
EXISTING (To be retained)	Blue
EXISTING (To be demolished)	Yellow

Buildingwise Floor FAR Details

Floor Name	Building Name A (SMT JANKI DEVI)		Total	
	Proposed Built Up Area (Sq.mt.)	Proposed FAR Area (Sq.mt.)	Total Proposed Built Up Area (Sq.mt.)	Total FAR Area (Sq.mt.)
Ground Floor	95.36	95.36	95.36	95.36
First Floor	95.36	95.36	95.36	95.36
Terrace Floor	0.00	0.00	0.00	0.00
Total :	190.72	190.72	190.72	190.72

Building USE/SUBUSE Details

Building Name	Building Use	Building SubUse	Building Structure
A (SMT JANKI DEVI)	Residential	Residential Bldg/Apartment	Non-Highrise

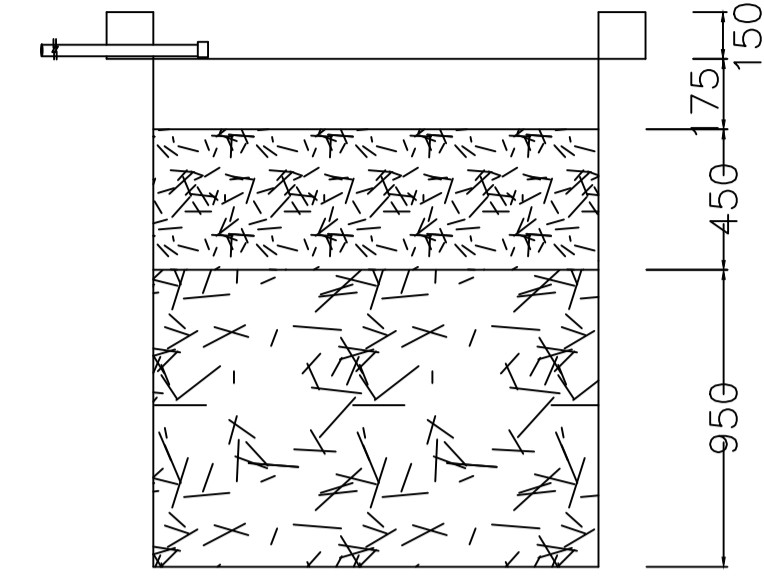

SECTION AT Y-Y

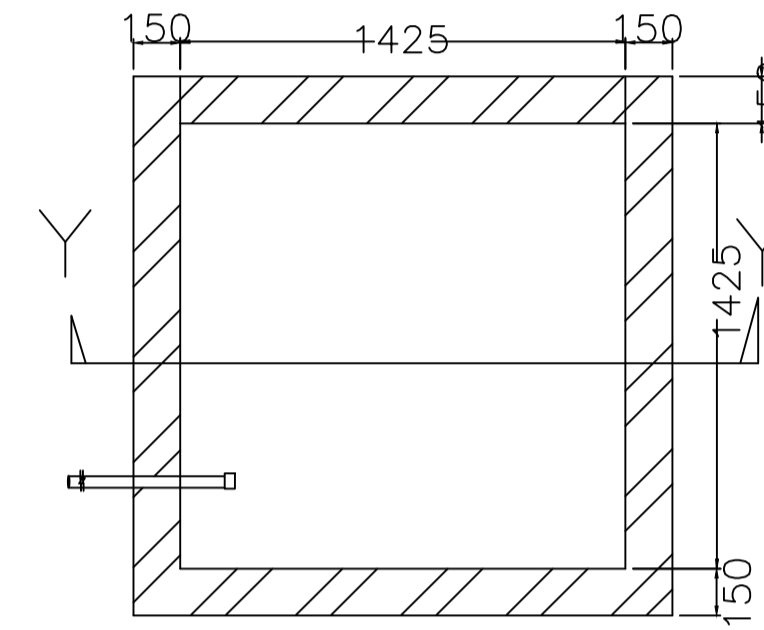

PLAN OF RECHARGE WELL WATER HARVESTING

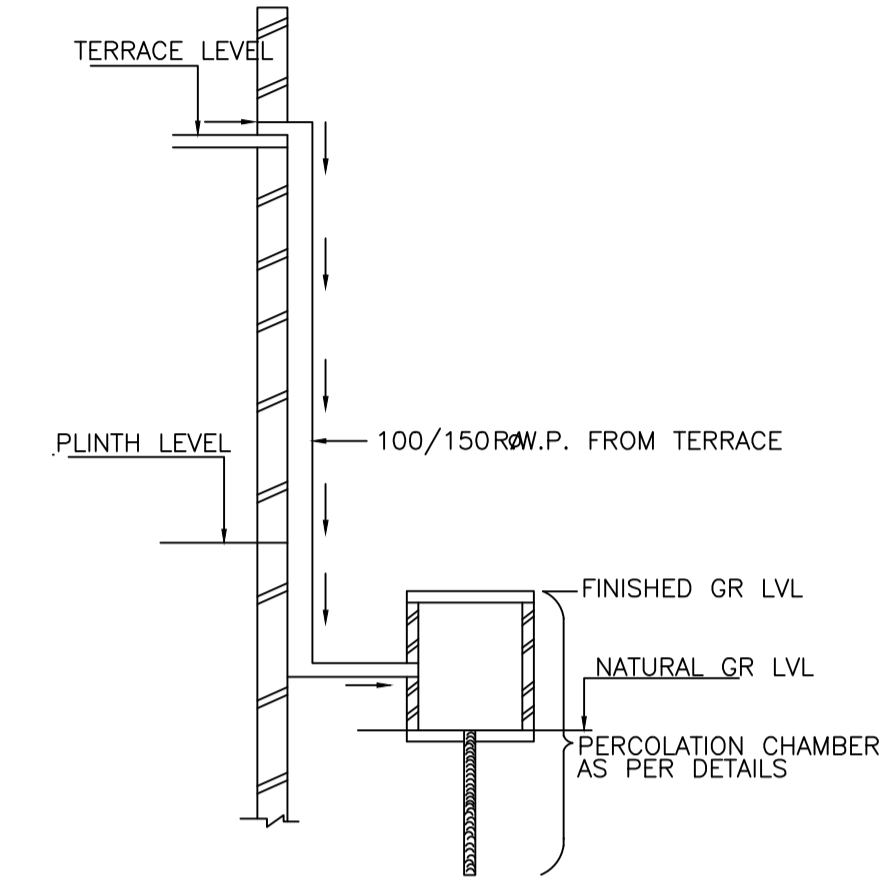

ROOF TOP RAIN WATER COLLECTION SYSTEM

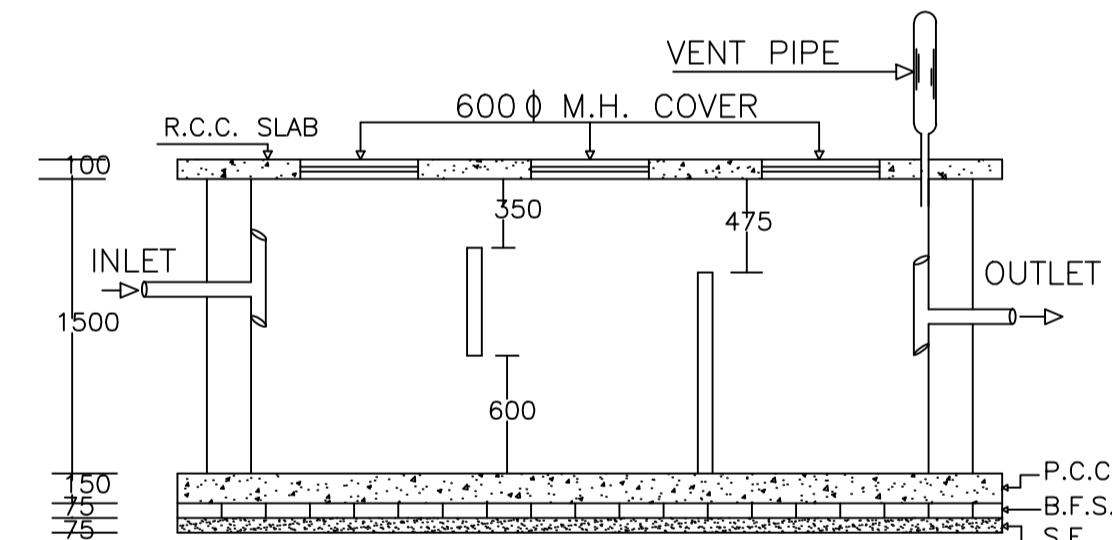

PLAN OF SEPTIC TANK

LTP NAME AND SIGNATURE	STRUCTURAL ENG'S NAME AND SIGNATURE	BUILDER NAME AND SIGNATURE	DIGITAL SIGNATURE
RAJEEV RANJAN SINGH DMC/ENG/0032/2017			

Proposal Basic Information

Proposal File No.	DMC/BP/0227/W22/2019
Owner Name	SMT JANKI DEVI
Khata No	OLD-90, NEW-47
Plot No	OLD-1376, NEW-1751
Village Name	Bhelaland
Use	Residential
SubUse	Bungalow/ Dwelling / Non Apartment

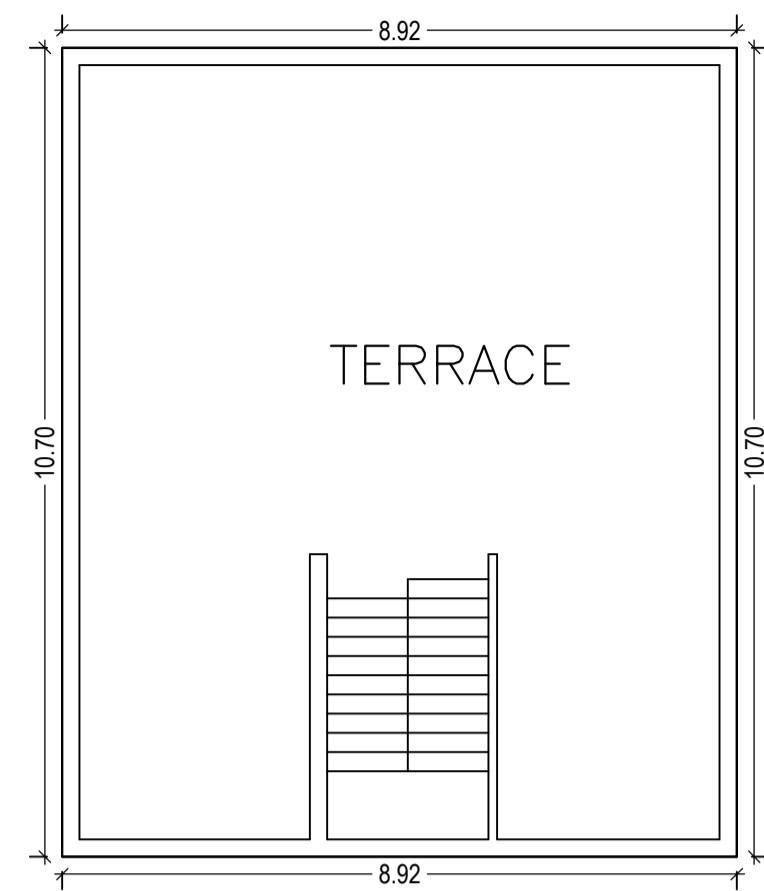

TERRACE FLOOR PLAN (SCALE 1:100)

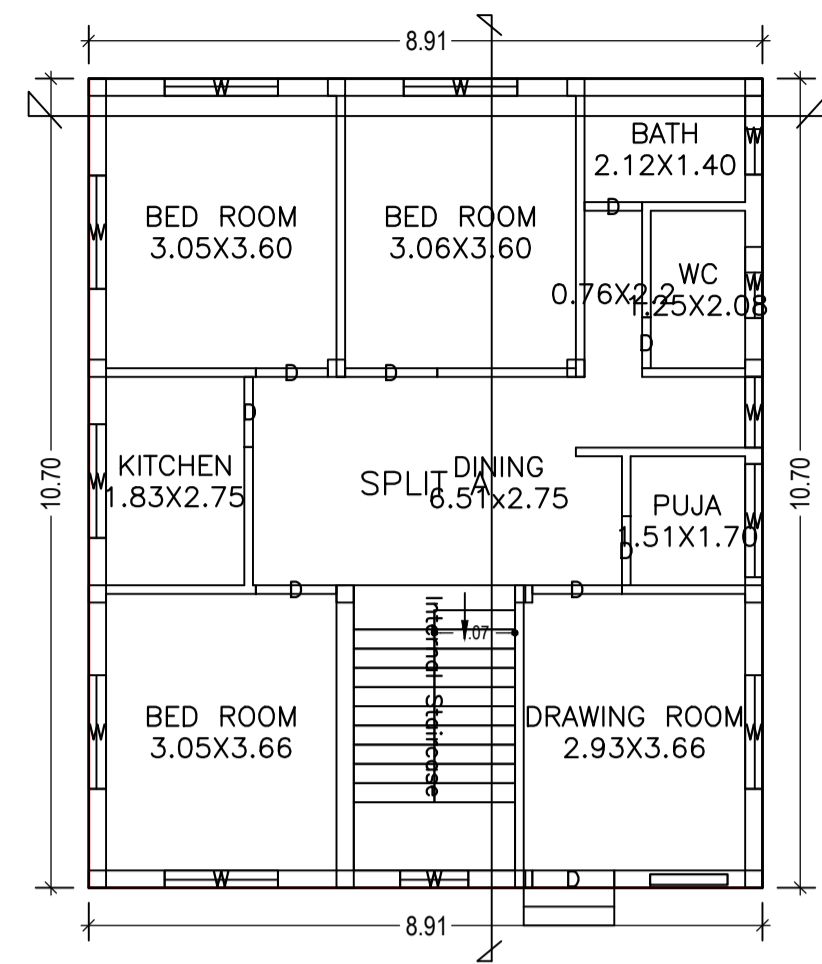

GROUND FLOOR PLAN (Proposed) (SCALE 1:100)

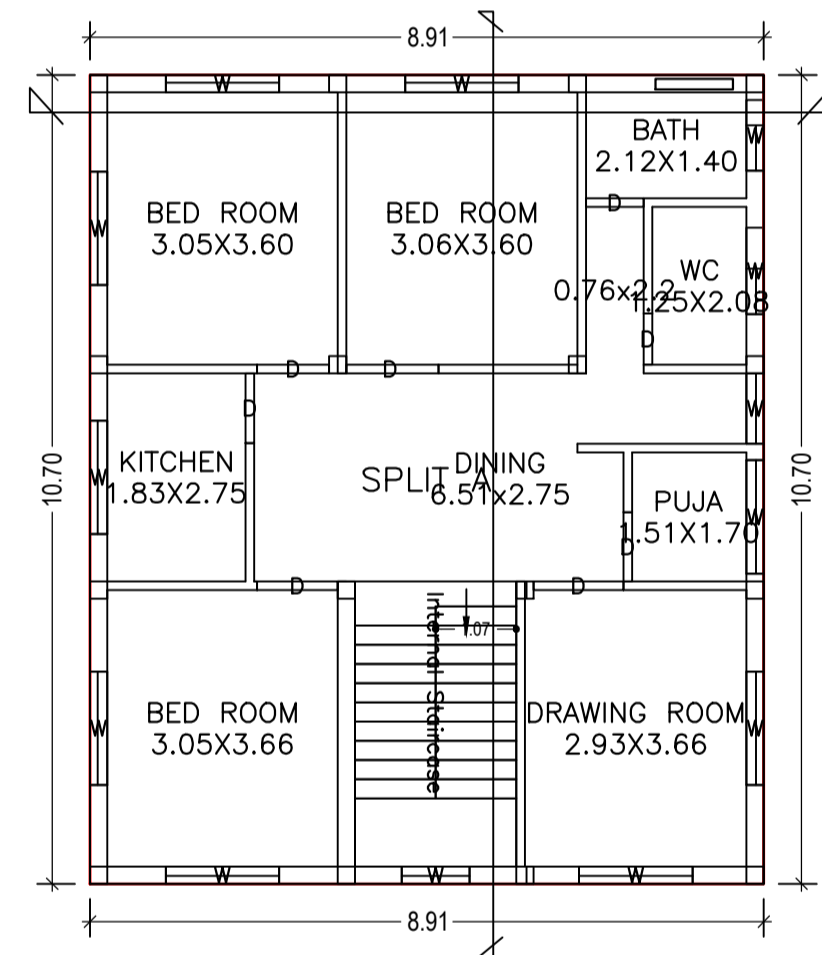

FIRST FLOOR PLAN (Proposed) (SCALE 1:100)

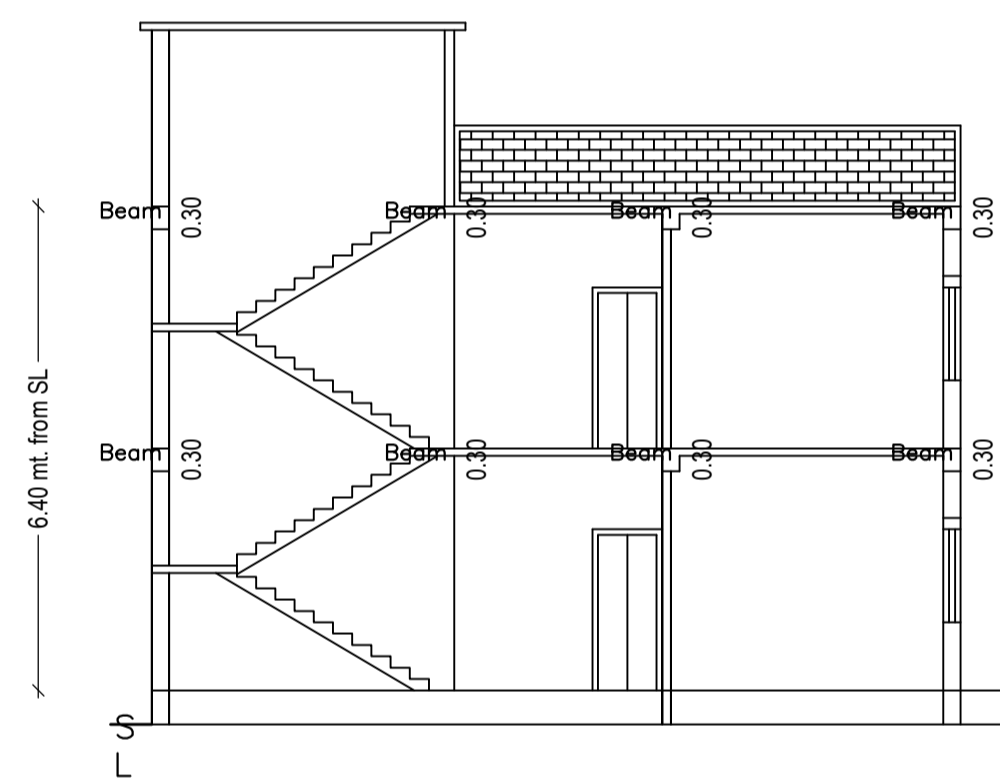

SECTION ON X-X

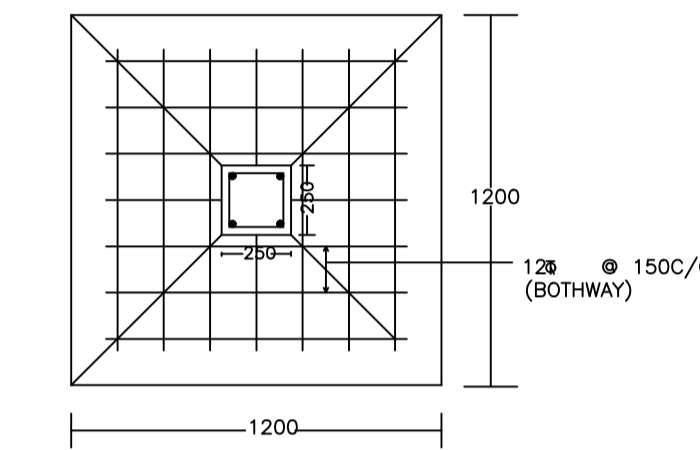
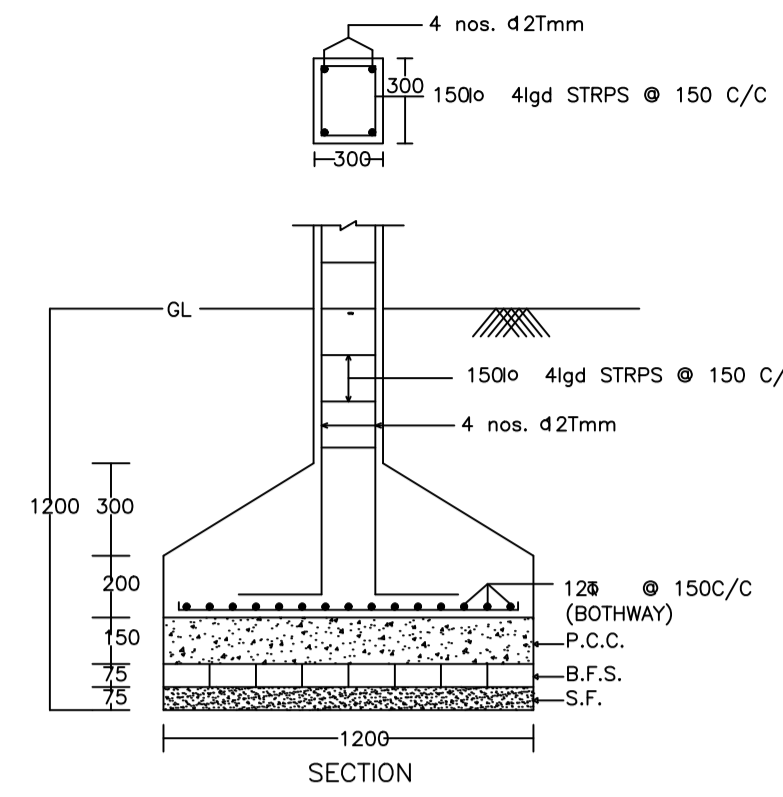

DETAIL OF COLUMNS

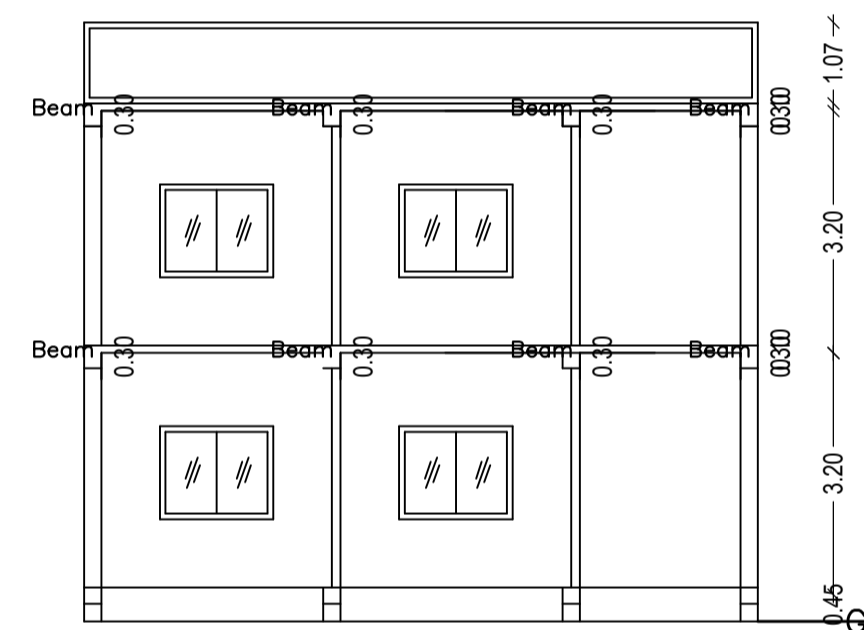

SECTION ON Y-Y

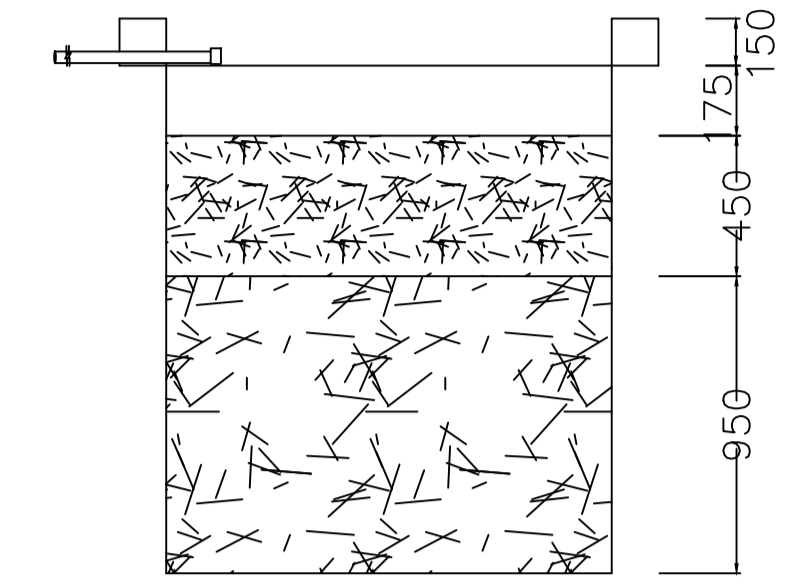

SECTION AT Y-Y

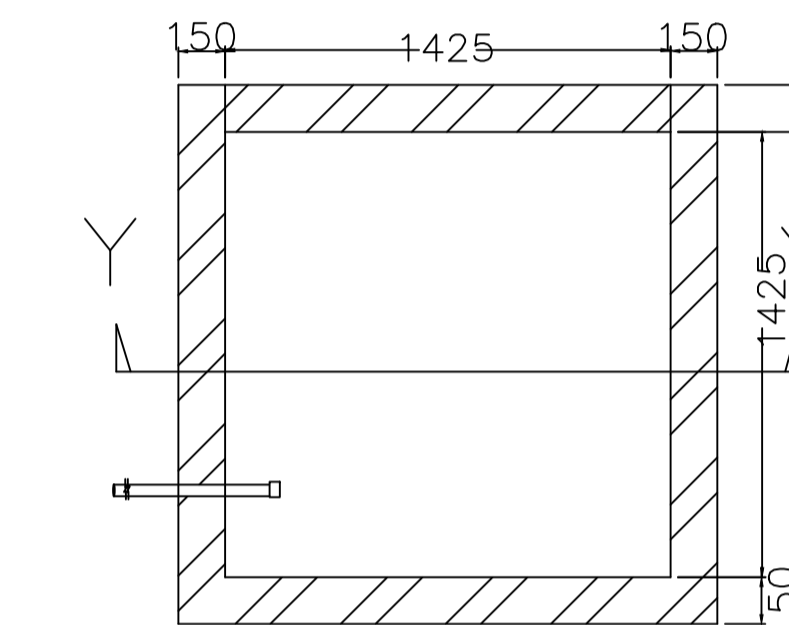

PLAN OF RECHARGE WELL WATER HARVESTING

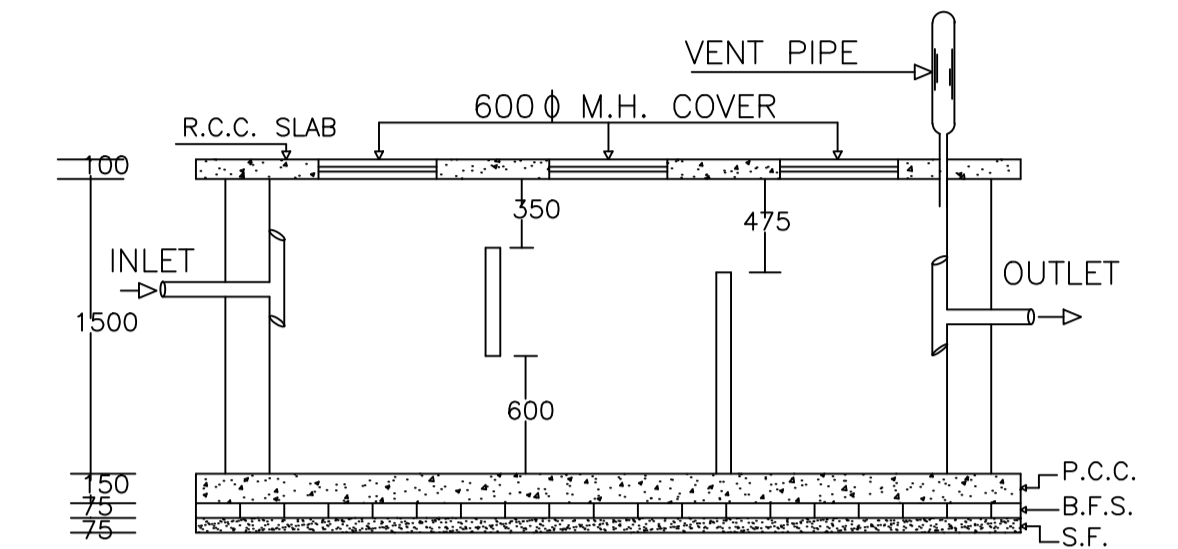

PLAN OF SEPTIC TANK

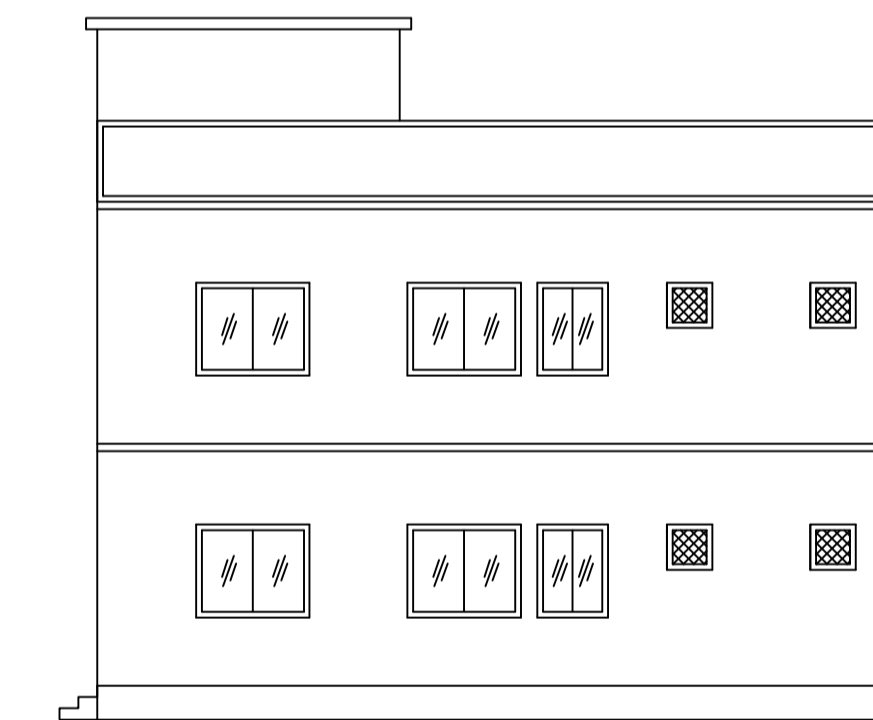

RIGHT SIDE ELEVATION

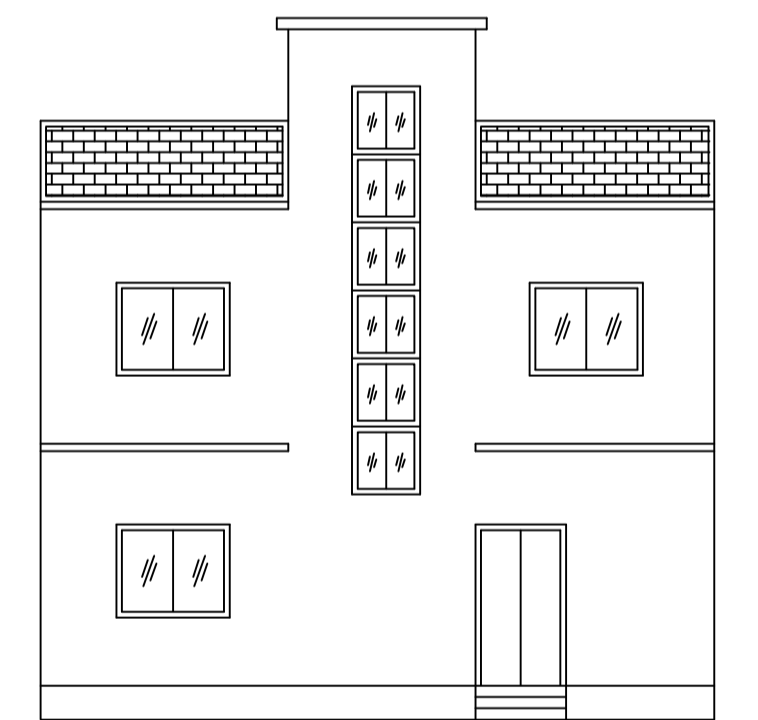

FRONT ELEVATION

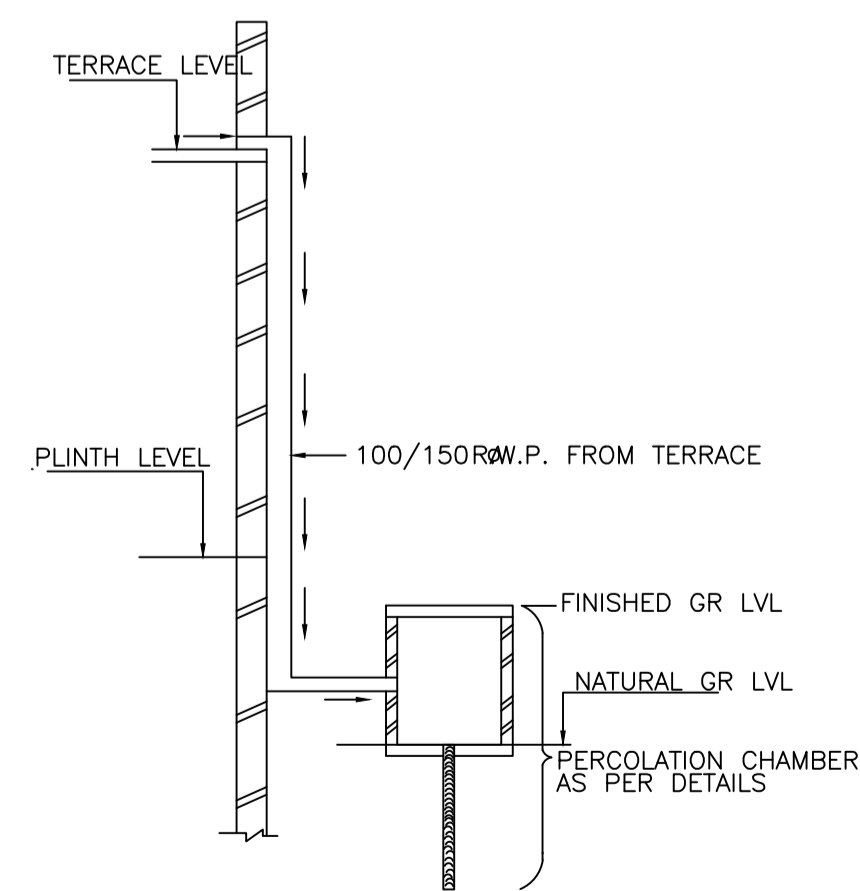

ROOF TOP RAIN WATER COLLECTION SYSTEM

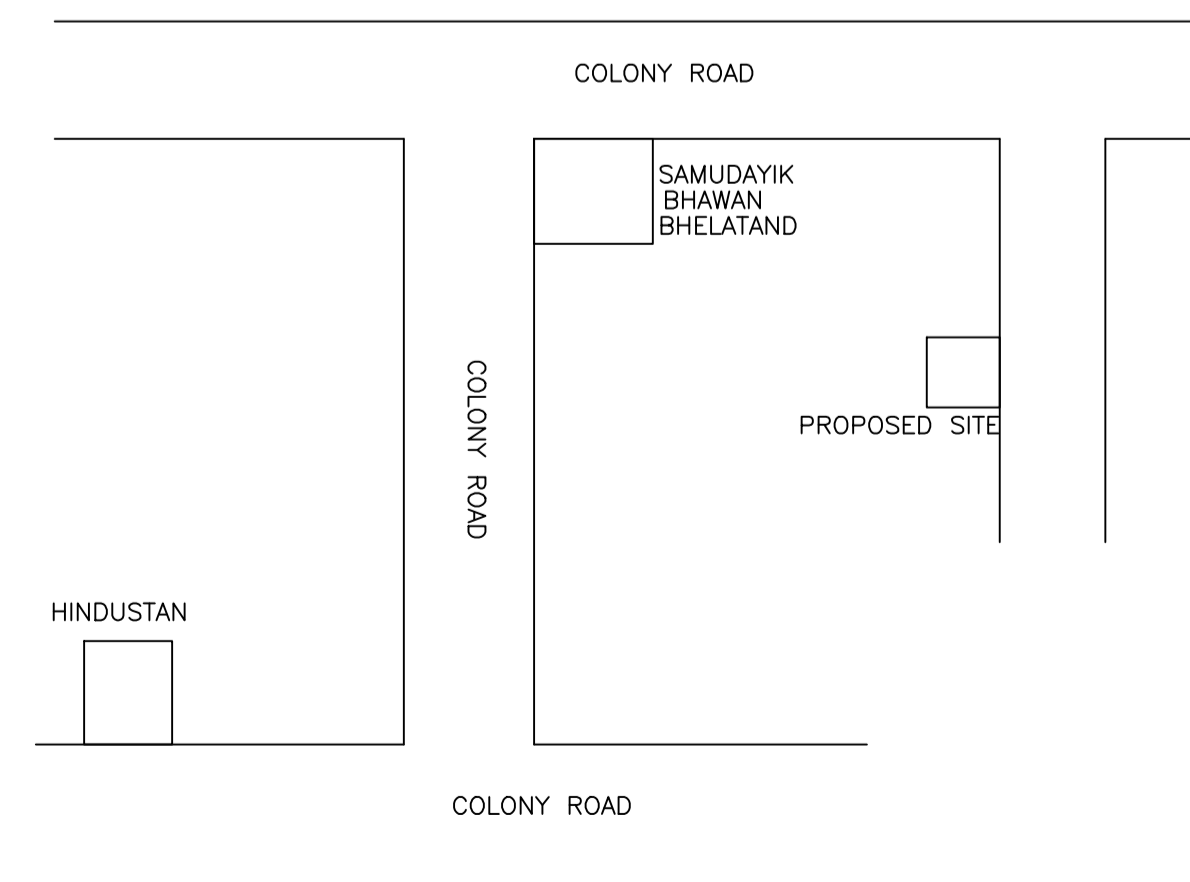

LOCATION PLAN

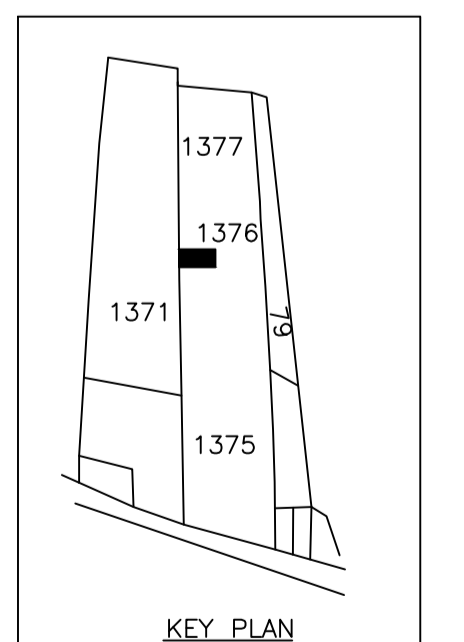

KEY PLAN

LTP NAME AND SIGNATURE	STRUCTURAL ENG'S NAME AND SIGNATURE	BUILDER NAME AND SIGNATURE	DIGITAL SIGNATURE
RAJEEV RANJAN SINGH DMC/ENG/0032/2017			