

Proposal Basic Information

Proposal File No.	DMC/BP/0132/W23/2019
Owner Name	DIPAK KUMAR DUTTA, ALPANA DUTTA
Khata No	OLD (41,87,1) NEW(362, 48, 625)
Plot No	OLD(26, 267, 252), NEW(684, 239, 704)
Village Name	Kolakusma
Use	Residential
SubUse	Bungalow/ Dwelling / Non Apartment

AREA STATEMENT DHANBAD MUNICIPAL CORPORATION	VERSION NO. : 1.0.36 VERSION DATE: 29/04/2019
PROJECT DETAIL:	
Region: JHARKHAND URBAN	Plot Use: Residential
LOCAL BODIES	Plot SubUse: Bungalow/ Dwelling / Non Apartment
District: DHANBAD	PlotNearbyReligiousStructure: NA
Authority: DHANBAD MUNICIPAL CORPORATION	Plot/SubPlot No: OLD(26, 267, 252), NEW(684, 239, 704)
Inward No: DMC/BP/0132/W23/2019	North: Plot No. - PART OF PLOT NO. 266
Application Type: General Proposal	South: Road Width - 4.57
Project Type: Building Permission	East: Road Width - 4.57
Nature of Development: New	West: Plot No. - PART OF PLOT NO. 252
Location of Development Area: Old Area	
AREA DETAILS:	SQ.MT.
AREA OF PLOT (Minimum)	299.42
NET AREA OF PLOT(Gross Plot Area - Deduction from Gross Plot area)	299.42
Deduction for Balance Plot Area(from Gross Plot Area)	
Common Plot	46.75
Total	46.75
BALANCE AREA OF PLOT(Net Plot Area - Recreational/Amenity space)	252.67
PLOT AREA FOR COVERAGE(Net Plot Area)	299.42
Plot Area for FAR (Net Plot Area + RoadWidening Area)	299.42
COVERAGE CHECK	
Permissible Coverage area (60.00 %)	179.65
Proposed Coverage Area (50.02 %)	149.77
Total Prop. Coverage Area (50.02 %)	149.77
Balance coverage area (9.98 %)	29.88
FAR CHECK	
Perm. FAR Area (1.50)	449.13
Maximum Permissible FAR Area (2.50)	748.55
Total Perm. FAR area	748.55
Residential FAR	449.32
Proposed FAR Area	449.32
Total Proposed FAR Area	449.32
Consumed FAR (Factor)	1.50
Balance FAR Area	299.23
Total Paid Proposed FAR Area	0.19
BUILT UP AREA CHECK	
Total Proposed BuiltUp Area	449.31
ARCHITECT (Regd)	HARSH NANDAN KUMAR
ENGINEER (Regd)	
SUPERVISOR (Regd)	
OWNER (Regd)	DIPAK KUMAR DUTTA, ALPANA DUTTA
DEVELOPMENT AUTHORITY	LOCAL BODY

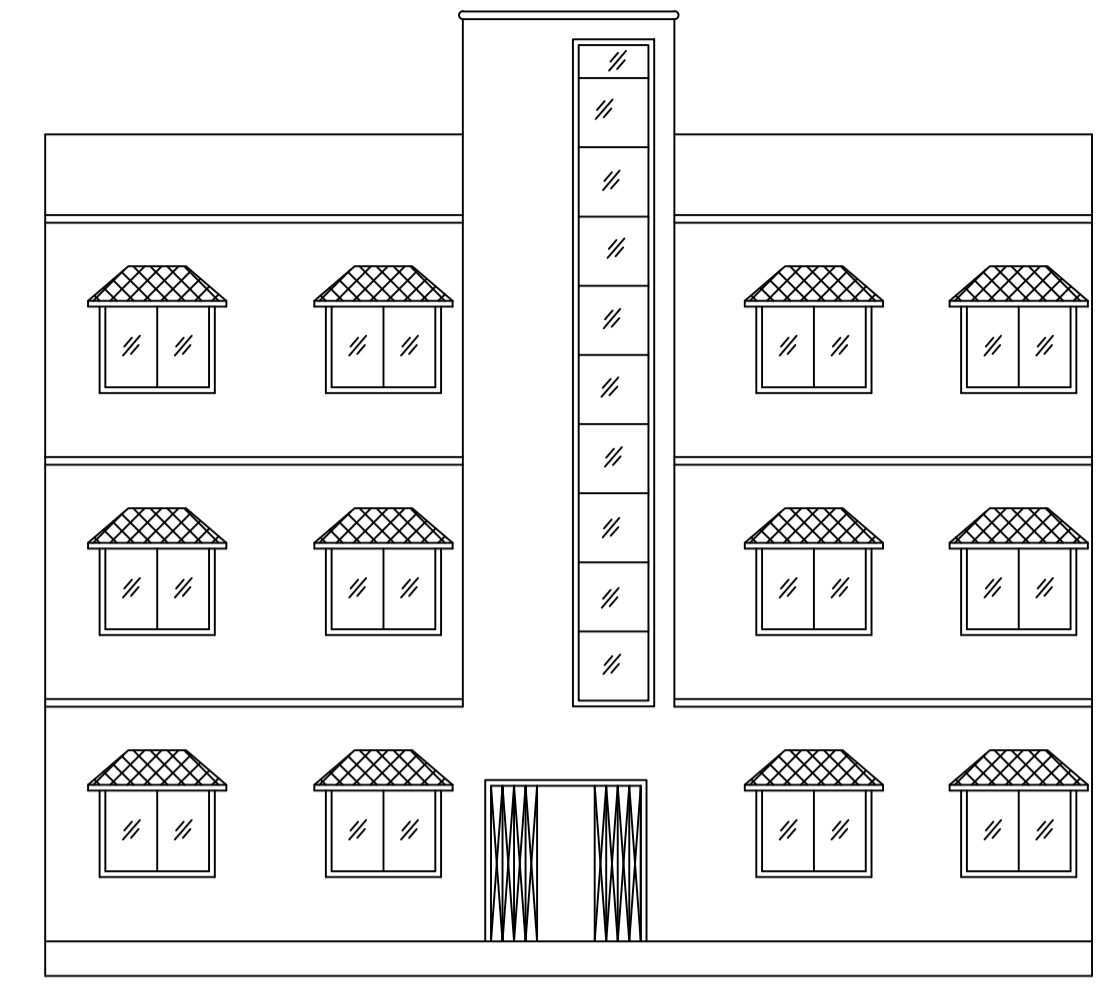
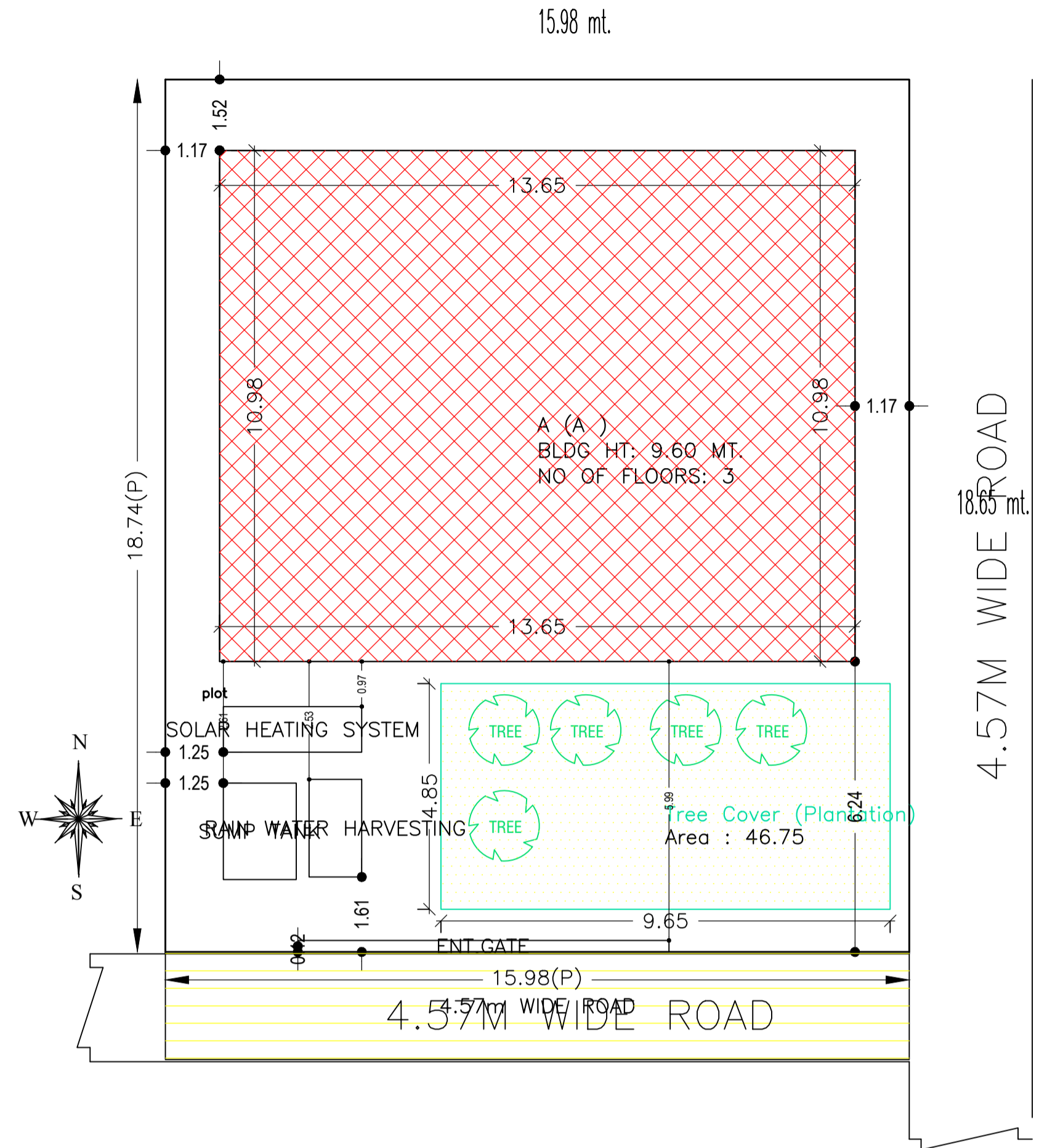

FRONT ELEVATION

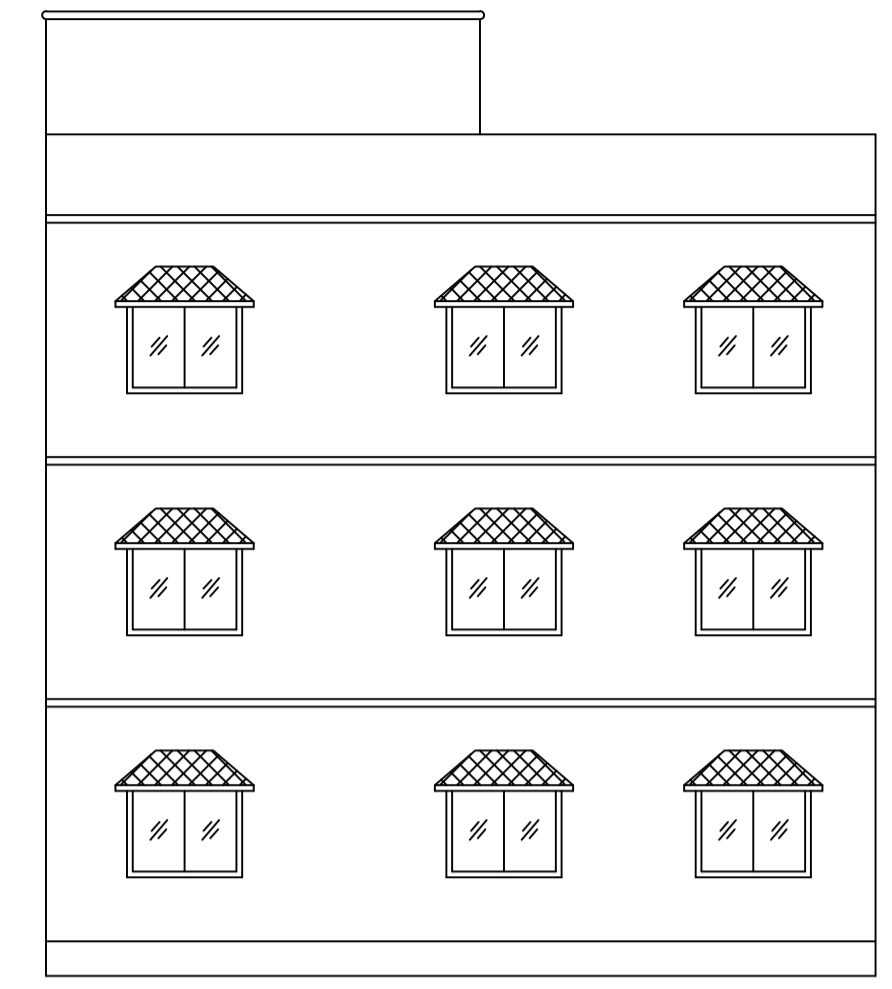

RIGHT SIDE ELEVATION

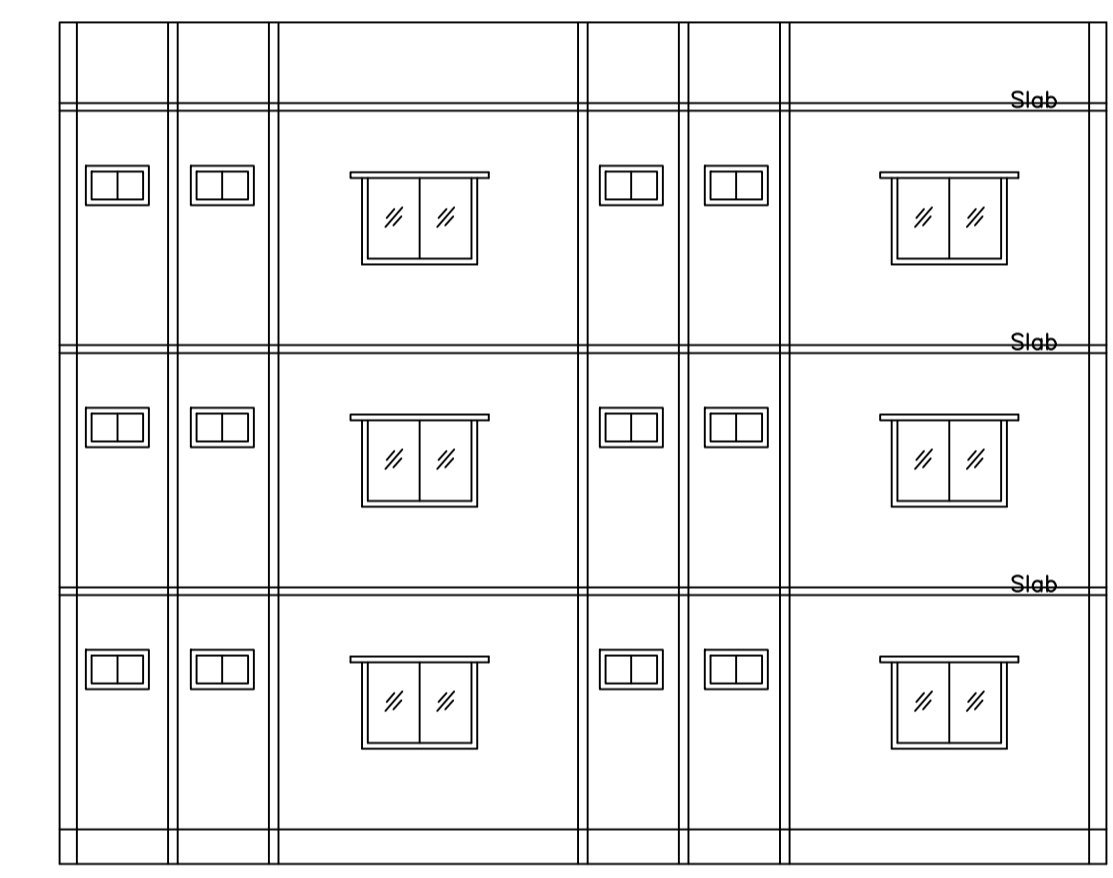

SECTION AT X-X

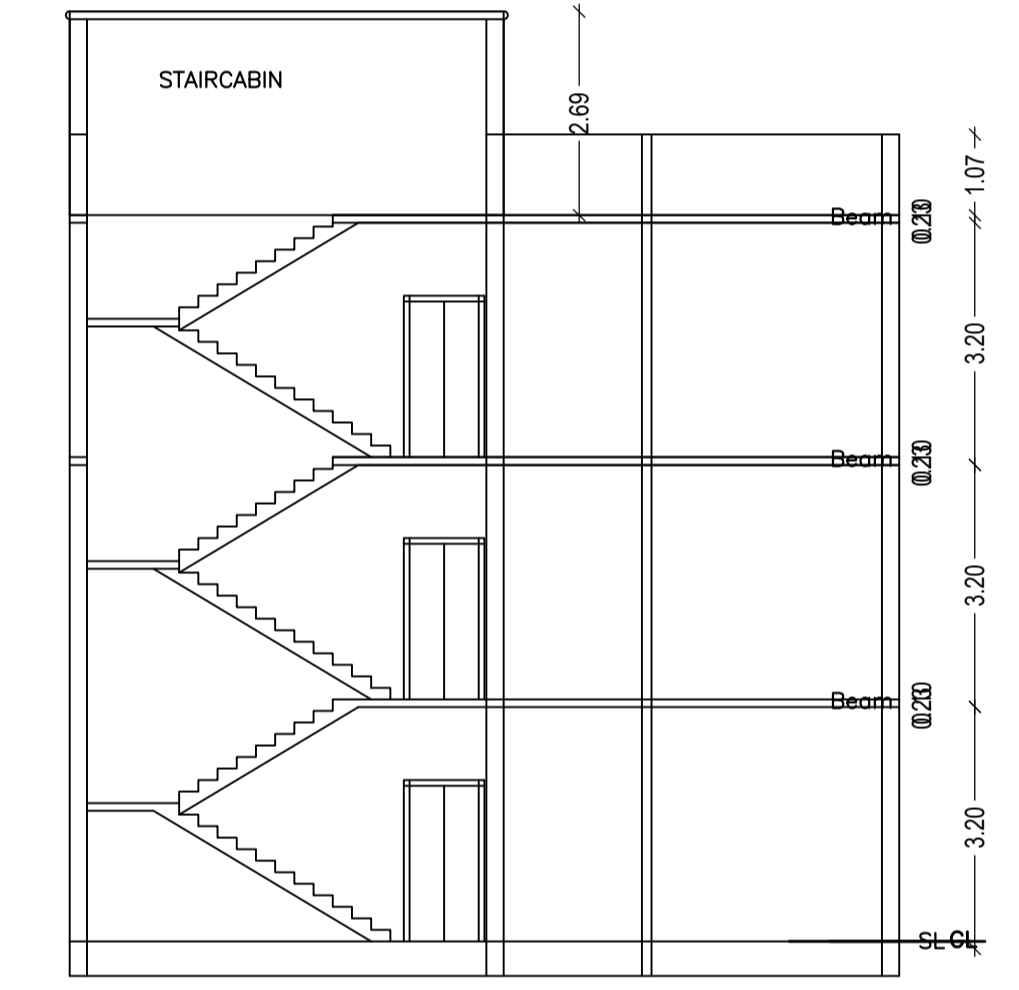

SECTION AT - YY

SITE PLAN

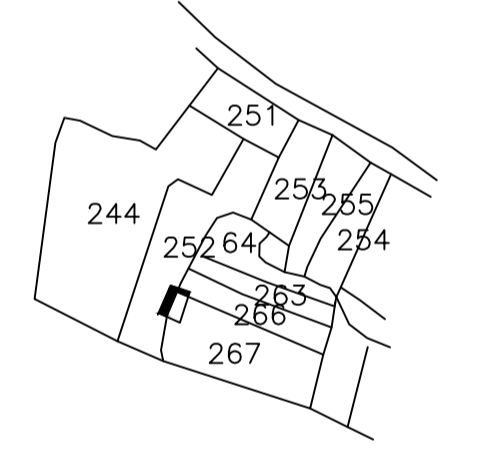

KEY PLAN

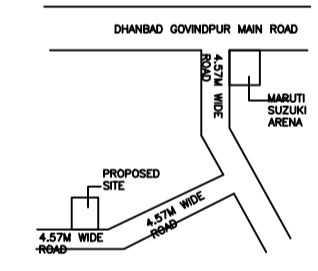

LOCATION PLAN

COLOR INDEX	
PLOT BOUNDARY	[Red Line]
ABUTTING ROAD	[Green Line]
PROPOSED CONSTRUCTION	[Yellow Line]
COMMON PLOT	[Blue Line]
ROAD WIDENING AREA	[Orange Line]
EXISTING (To be retained)	[Black Line]
EXISTING (To be demolished)	[White Line]

Building USE/SUBUSE Details

Building Name	Building Use	Building SubUse	Building Structure
A (A)	Residential	Residential Bldg/Apartment	Non-Highrise

SCHEDULE OF DOOR:

BUILDING NAME	NAME	LENGTH	HEIGHT	NOS
A (A)	D	0.90	2.10	30

SCHEDULE OF WINDOW/VENTILATION:

BUILDING NAME	NAME	LENGTH	HEIGHT	NOS
A (A)	W	1.14	1.20	42
A (A)	W	1.49	1.20	03
A (A)	W	1.75	1.20	03
A (A)	W	1.80	1.20	06
A (A)	W	2.85	1.20	03
A (A)	W	3.27	1.20	03

Building :A (A)

Floor Name	Total Built Up Area (Sq.mt.)	Proposed FAR Area (Sq.mt.)	Total FAR Area (Sq.mt.)	Total Consumed Additional FAR Area (Sq.mt.)	Tnmt (No.)
Ground Floor	149.77	149.77	149.77	149.77	01
First Floor	149.77	149.77	149.77	149.77	00
Second Floor	149.77	149.77	149.77	149.77	00
Terrace Floor	0.00	0.00	0.00	0.00	00
Total :	449.31	449.31	449.31	449.31	01
Total Number of Same Buildings	1				
Total :	449.31	449.31	449.31	449.31	01

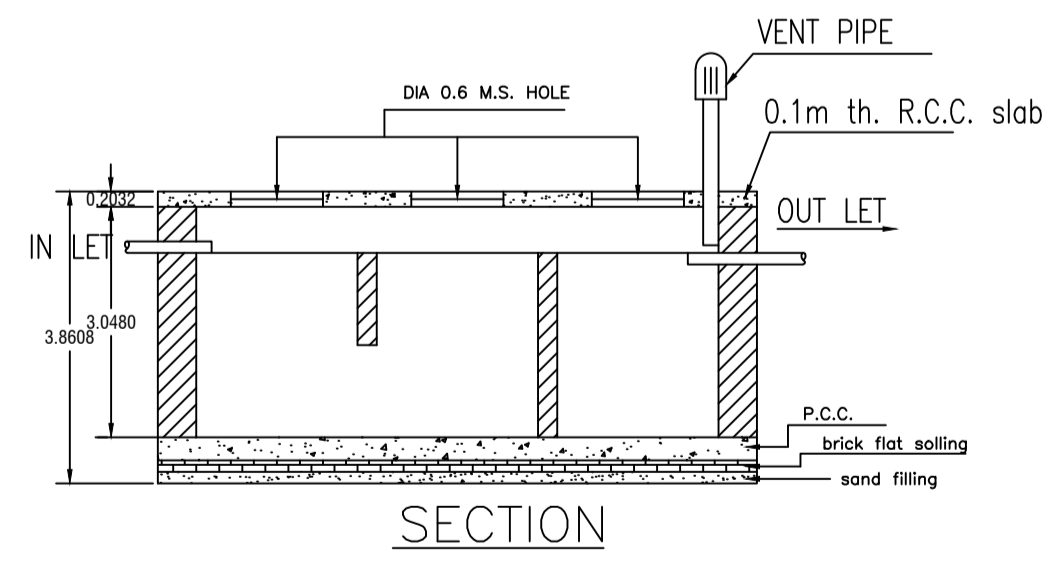

SECTION

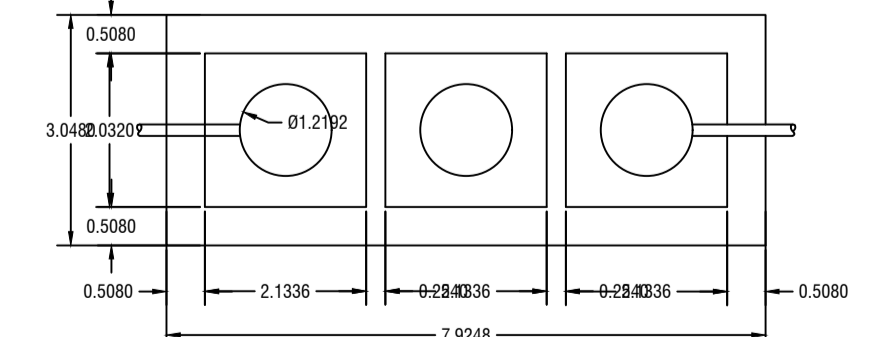

DETAILS OF SEPTIC TANK

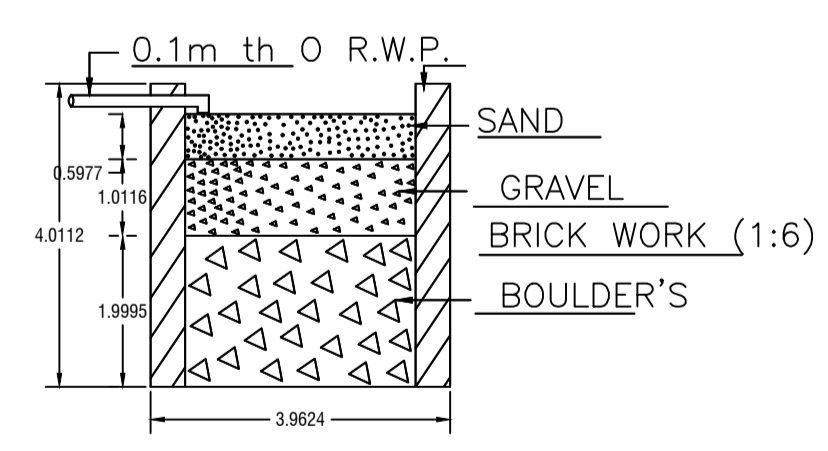

SECTION ON - AA

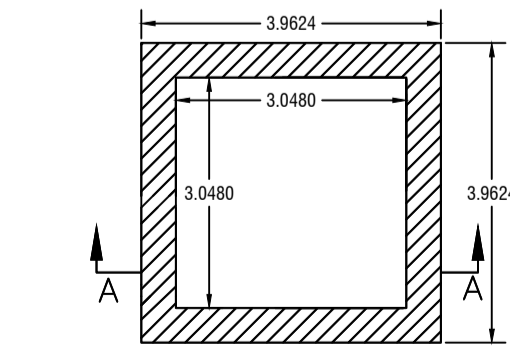

DETAIL'S OF WATER HARVESTING

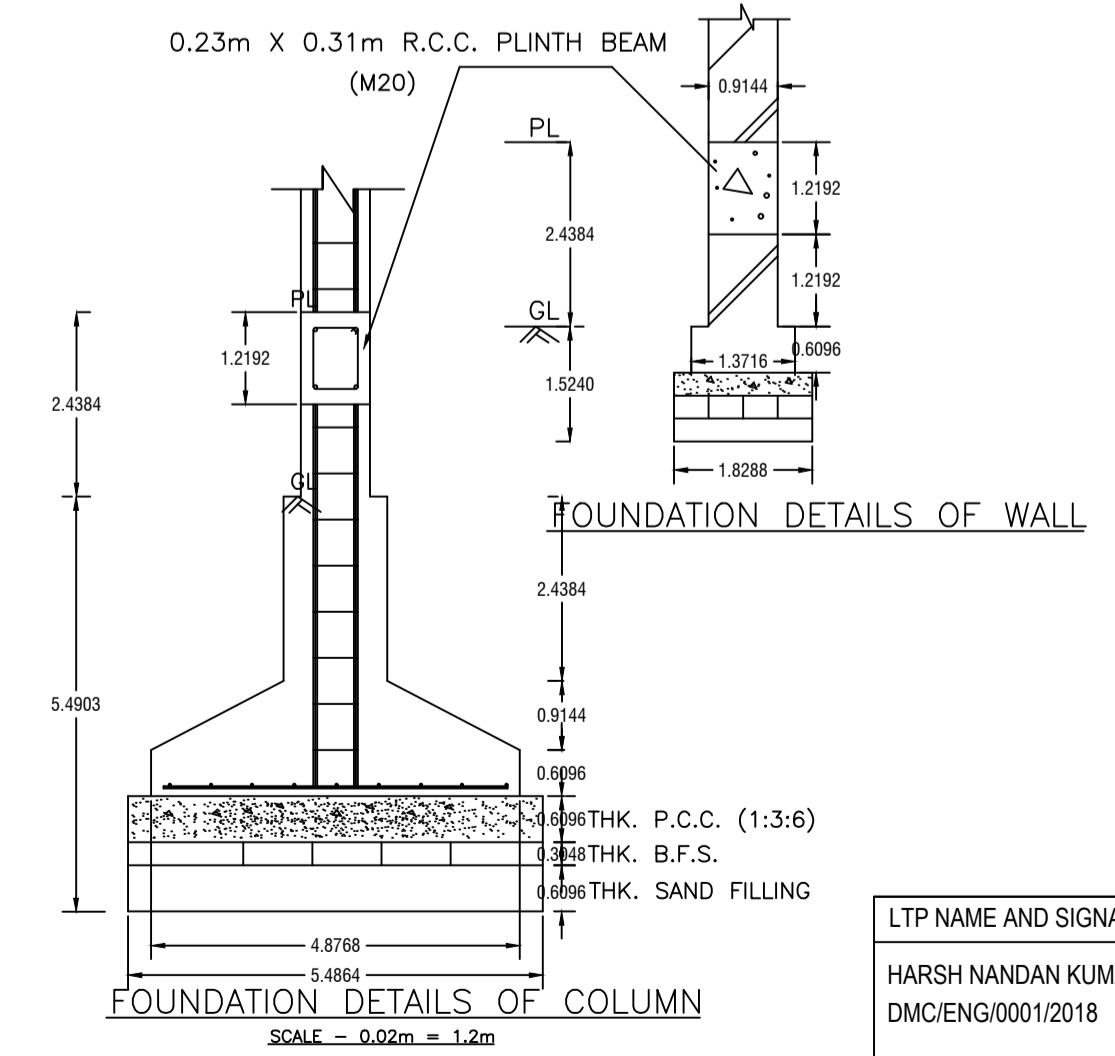

FOUNDATION DETAILS OF COLUMN

Buildingwise Floor FAR Details

Floor Name	Building Name		Total			
	Proposed Built Up Area (Sq.mt.)	Proposed FAR Area (Sq.mt.)	Total Proposed Built Up Area (Sq.mt.)	Total FAR Area (Sq.mt.)	Total Maximum Permissible FAR Area (Sq.mt.)	Total Paid Built Up Area (Sq.mt.)
Ground Floor	149.77	149.77	149.77	149.77	0.18	0.18
First Floor	149.77	149.77	149.77	149.77	0.00	0.00
Second Floor	149.77	149.77	149.77	149.77	0.00	0.00
Terrace Floor	0.00	0.00	0.00	0.00	0.00	0.00
Total :	449.31	449.31	449.31	449.31	0.18	0.18

FAR & Tenement Details (Table 4c-1)

Building	No. of Same Bldg	Total Built Up Area (Sq.mt.)	Proposed FAR Area (Sq.mt.)	Total FAR Area (Sq.mt.)	Total Consumed Additional FAR Area (Sq.mt.)	Tnmt (No.)
A (A)	1	449.31	449.31	449.31	449.31	01
Grand Total :	1	449.31	449.31	449.31	449.31	01

UnitBUA Table for Building :A (A)

FLOOR	Name	UnitBUA Type	UnitBUA Area	Carpet Area	No. of Rooms	No. of Tenement
GROUND FLOOR PLAN	SPLIT 1	FLAT	449.32	449.29	12	1
TYPICAL - 1, 2 FLOOR PLAN	SPLIT 1	FLAT	0.00	0.00	12	0
Total:	-	-	449.32	449.29	36	1

LTP NAME AND SIGNATURE	STRUCTURAL ENG'S NAME AND SIGNATURE	BUILDER NAME AND SIGNATURE	DIGITAL SIGNATURE
HARSH NANDAN KUMAR DMC/ENG/0001/2018			

Proposal Basic Information	
Proposal File No.	DMC/BP/0132/W23/2019
Owner Name	DIPAK KUMAR DUTTA, ALPANA DUTTA
Khata No	OLD (41,87,1) NEW(362, 48, 625)
Plot No	OLD(26, 267, 252), NEW(684, 239, 704)
Village Name	Kolakusma
Use	Residential
SubUse	Bungalow/ Dwelling / Non Apartment

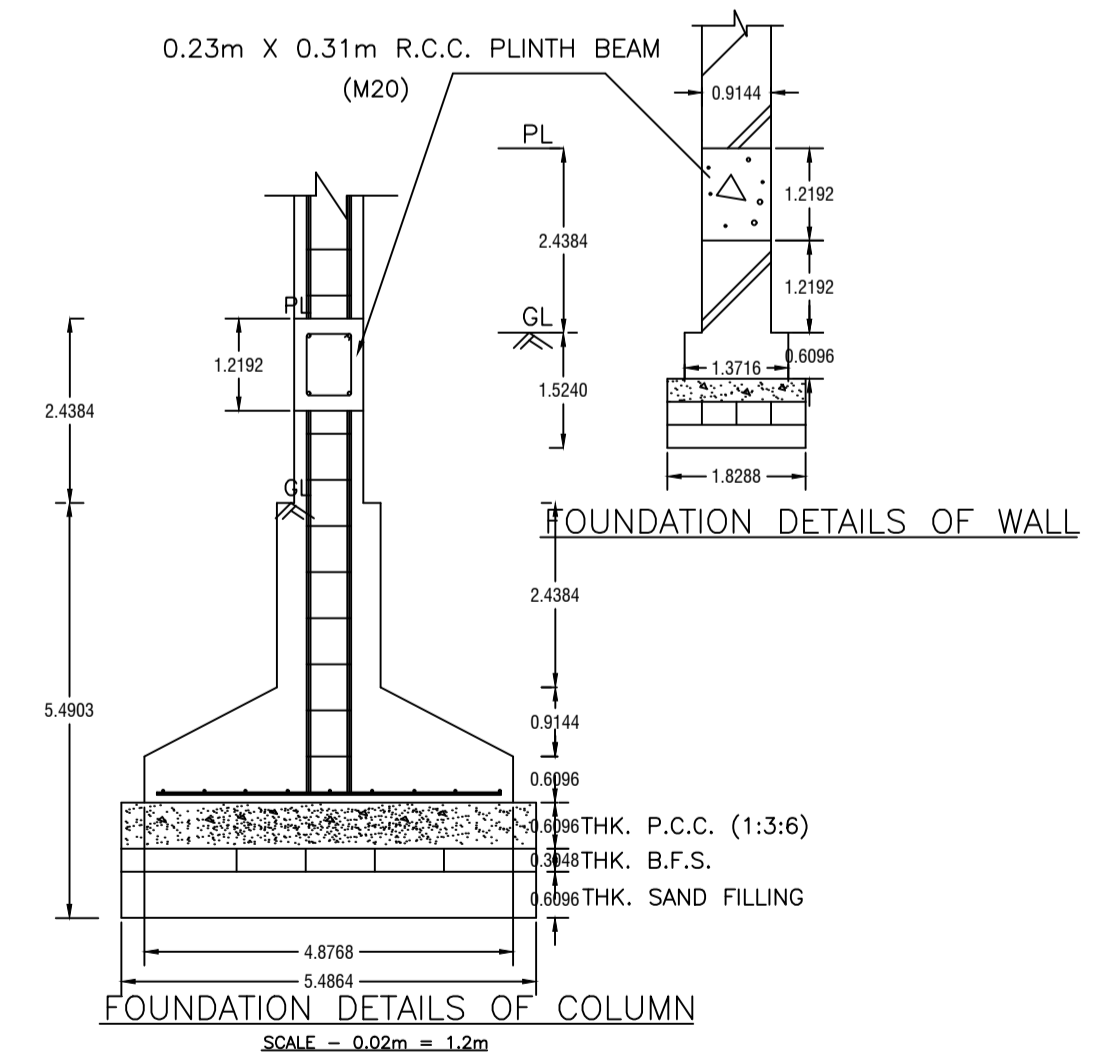
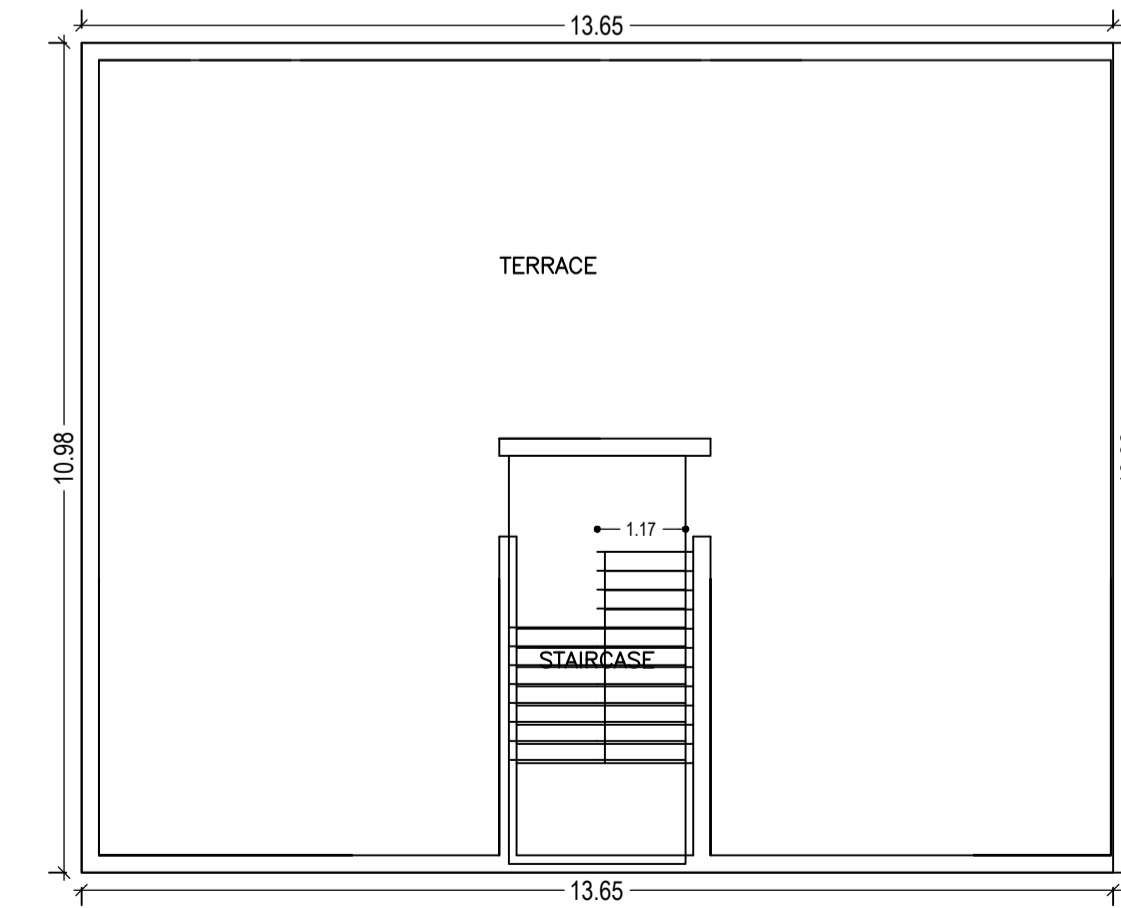
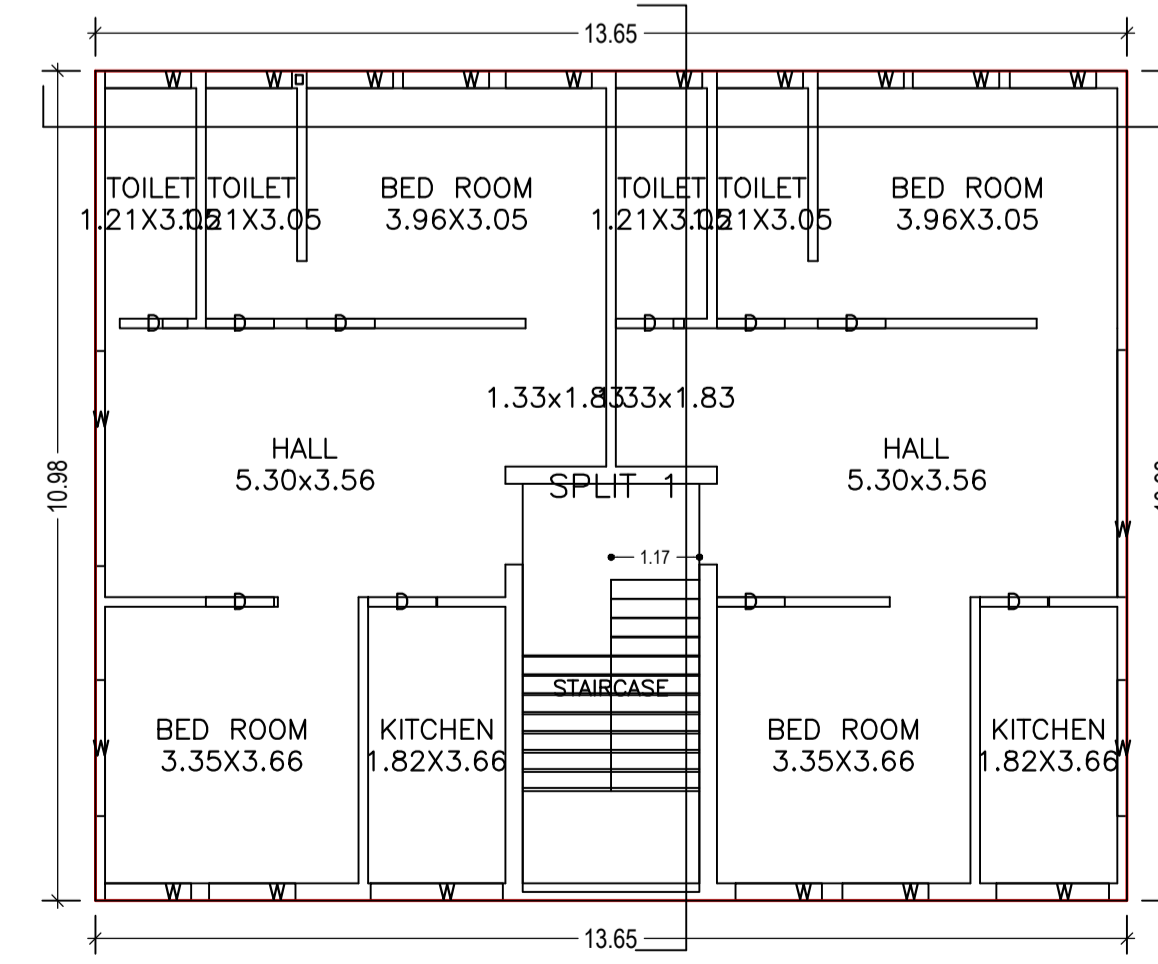
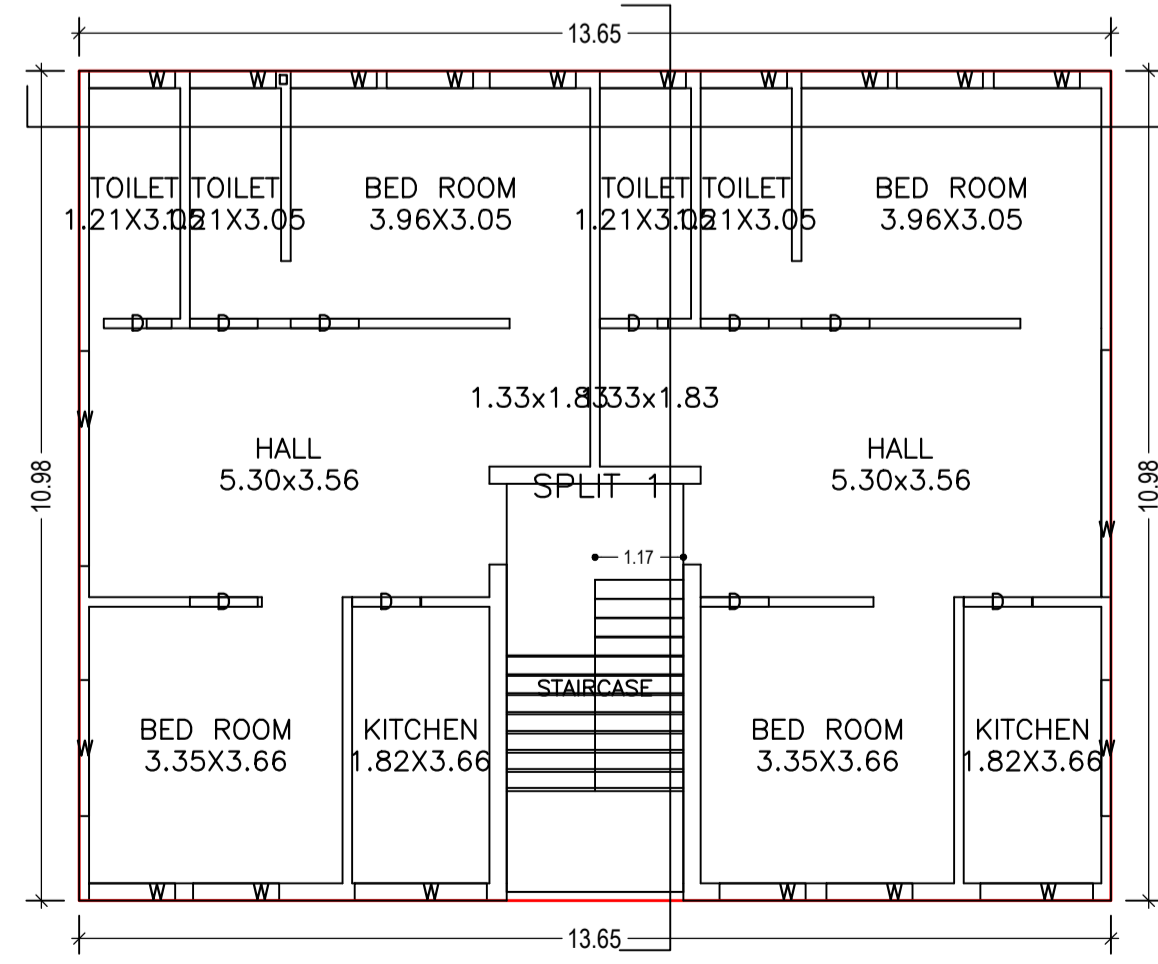
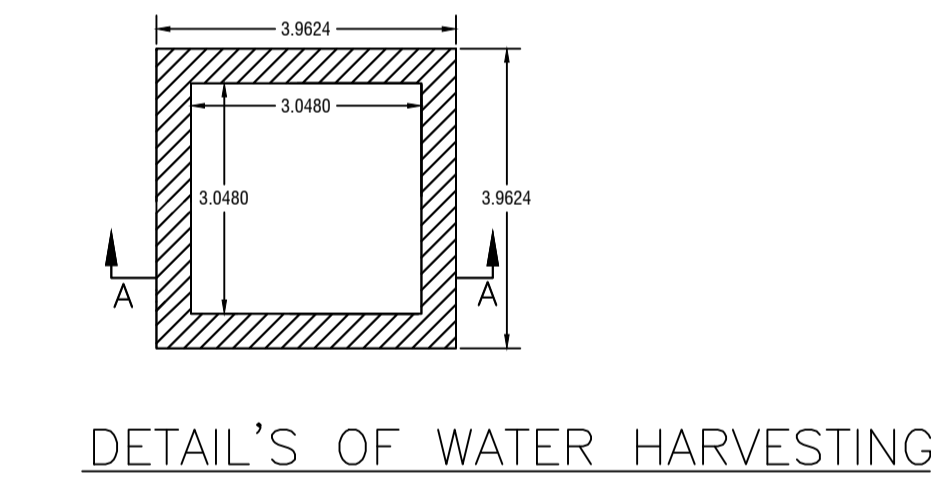
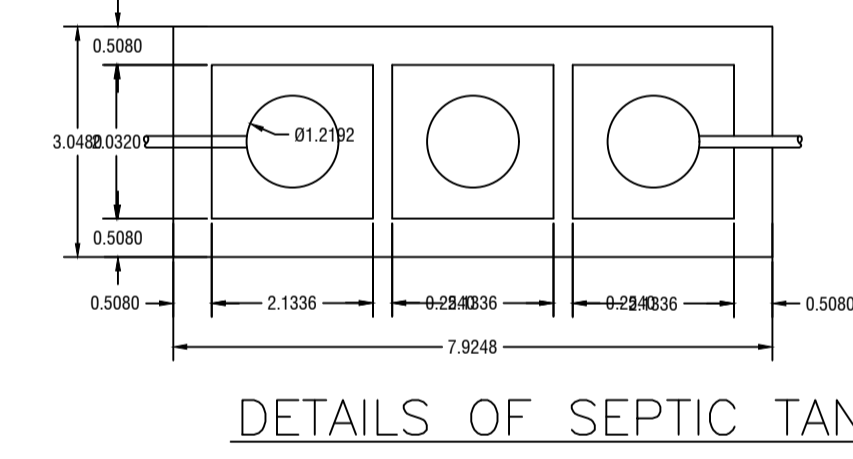
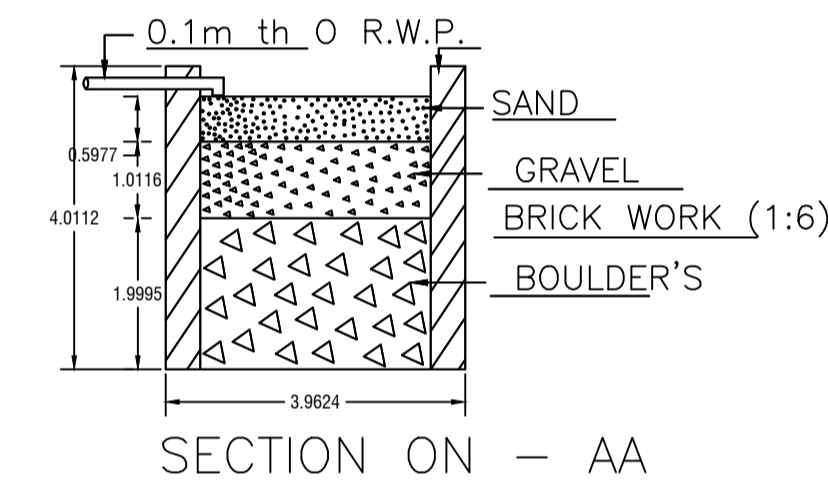
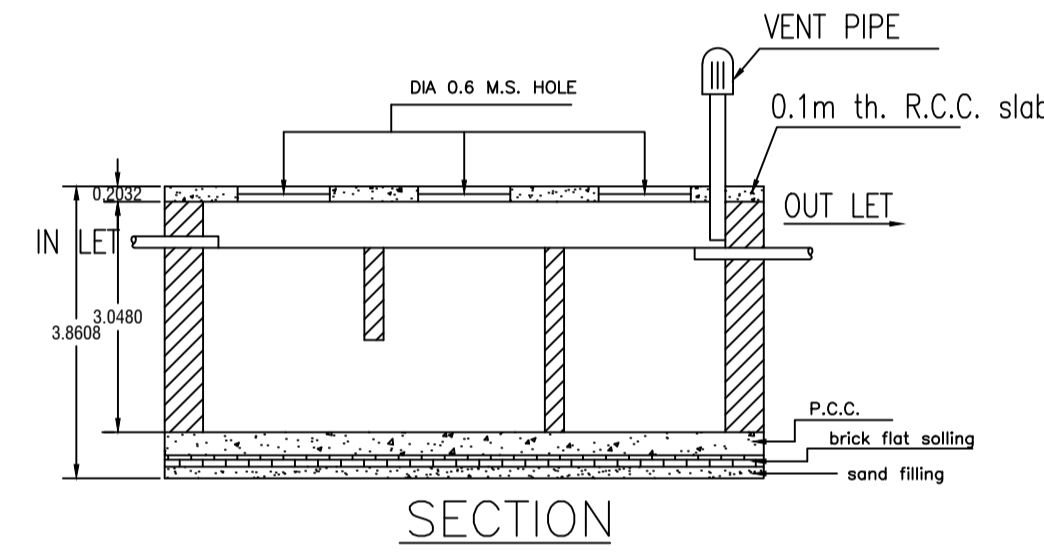
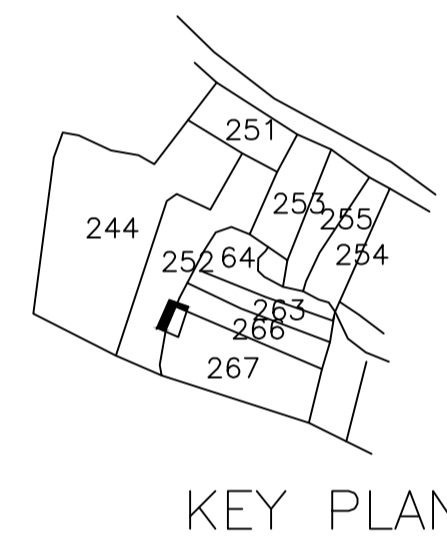
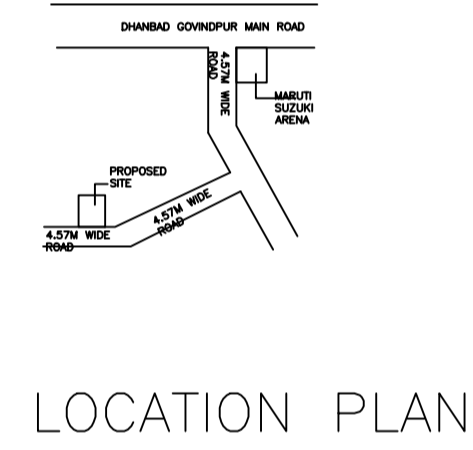
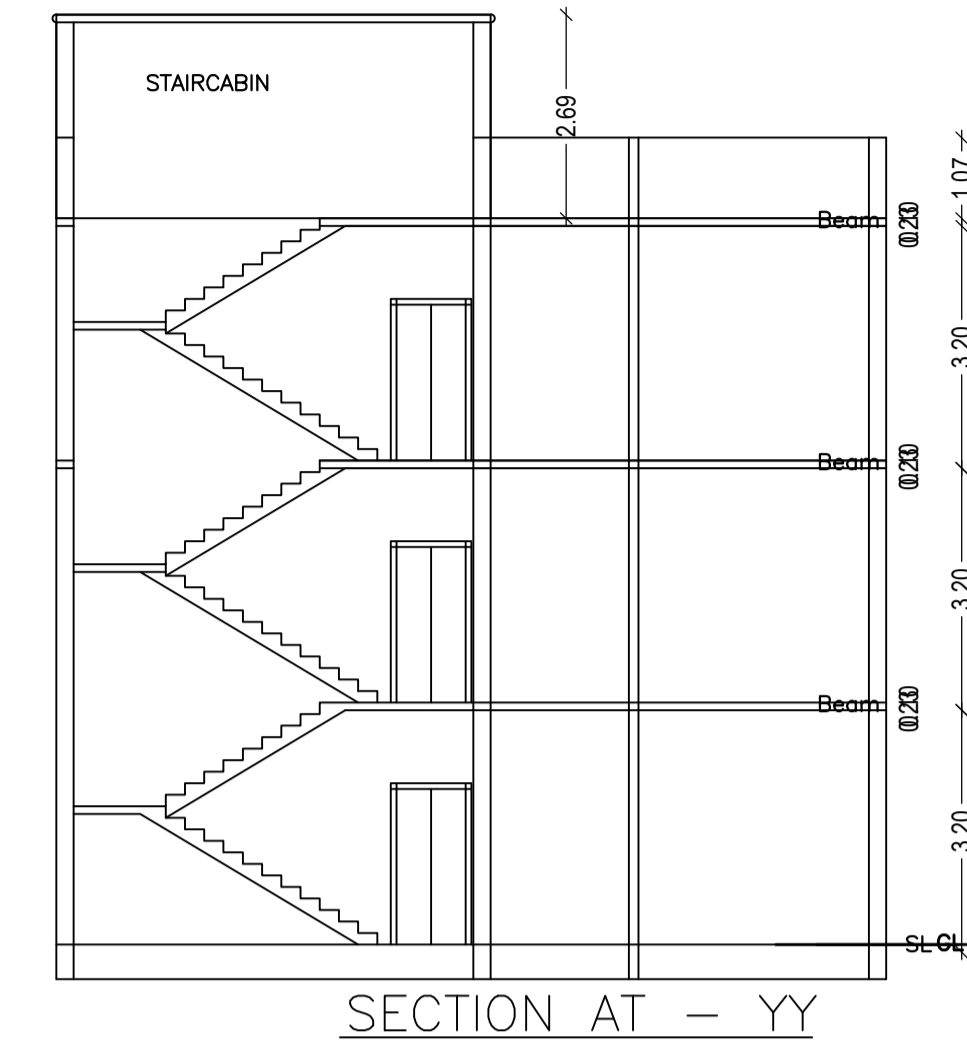
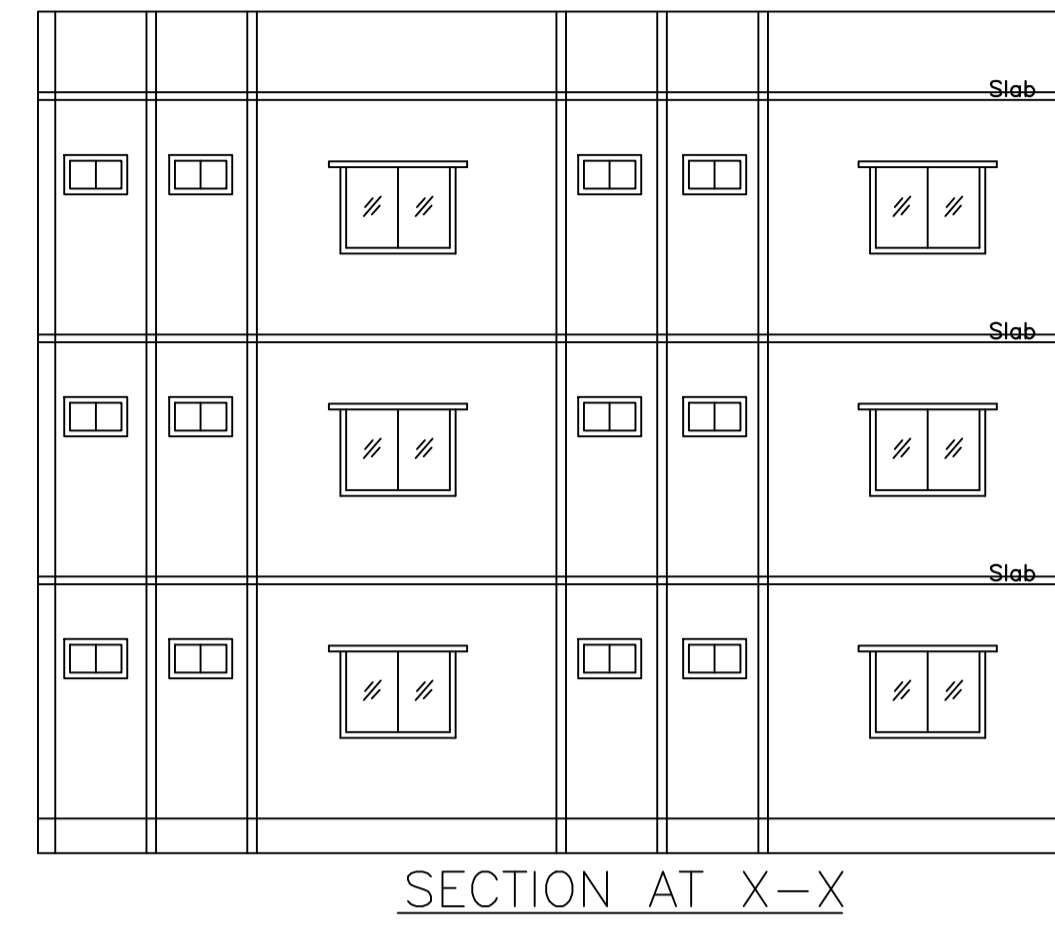
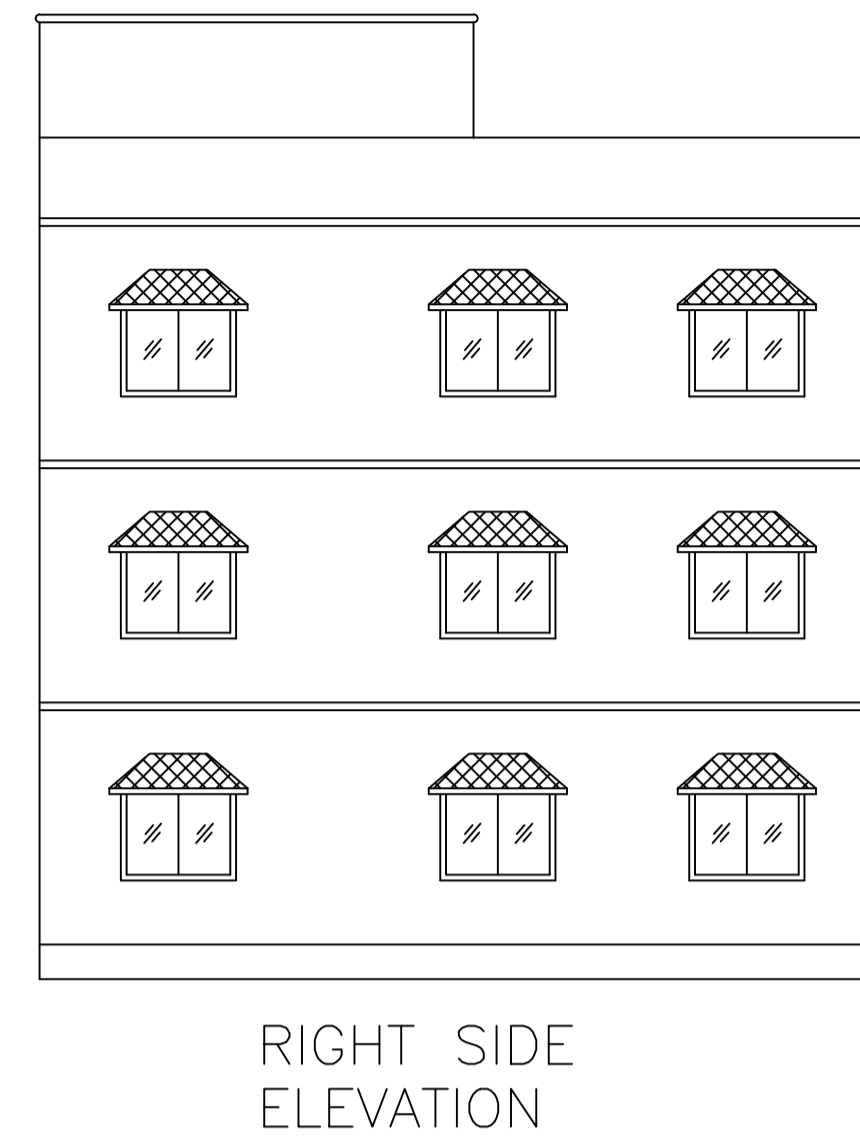
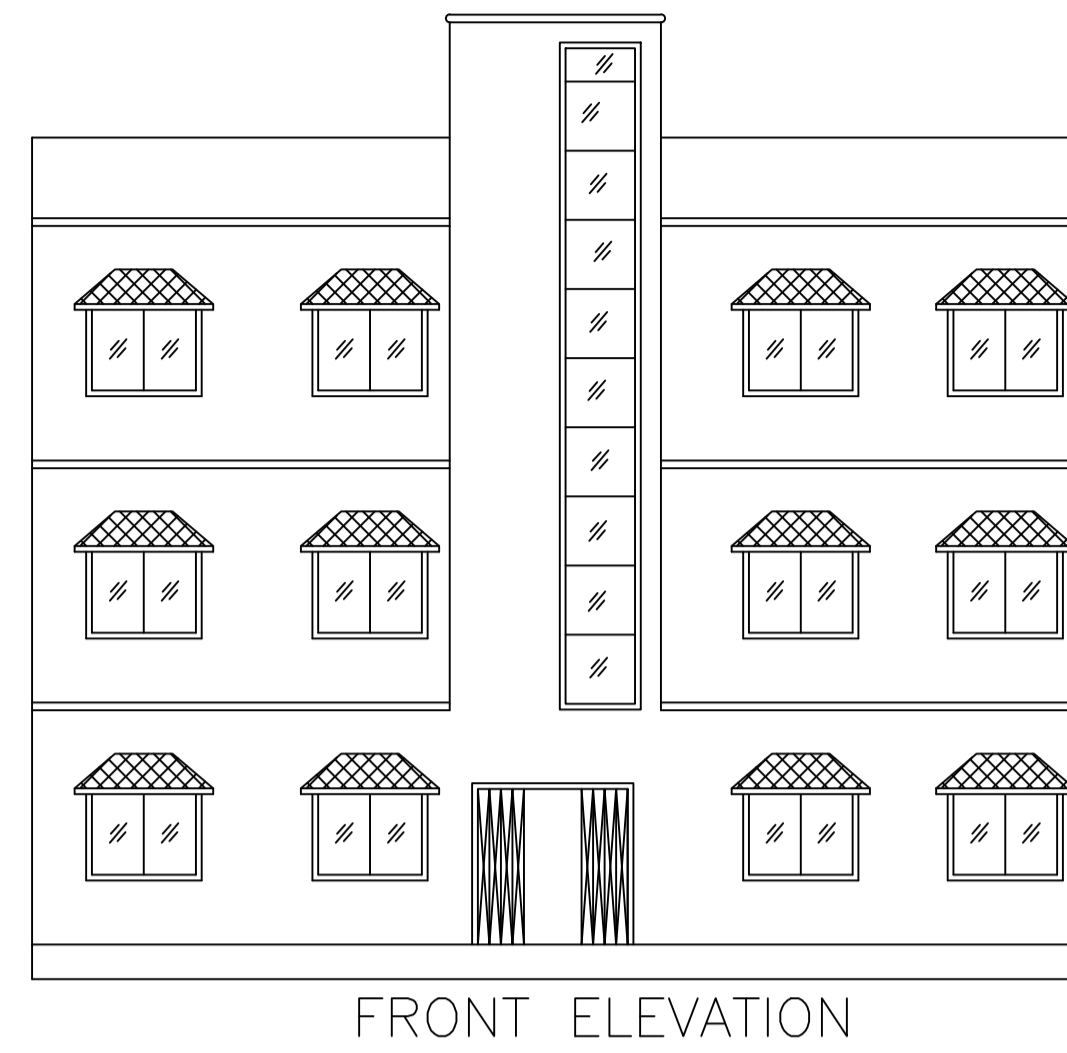

LTP NAME AND SIGNATURE	STRUCTURAL ENG'S NAME AND SIGNATURE	BUILDER NAME AND SIGNATURE	DIGITAL SIGNATURE
HARSH NANDAN KUMAR DMC/ENG/0001/2018			