

Proposal Basic Information

Proposal File No.	DMC/BP/0054/W23/2017
Owner Name	Sri.Janardan Prasad Singh and Other's
Khata No	41
Plot No	2082 (P)
Village Name	Kolakusma
Use	Assembly
SubUse	Assembly Hall

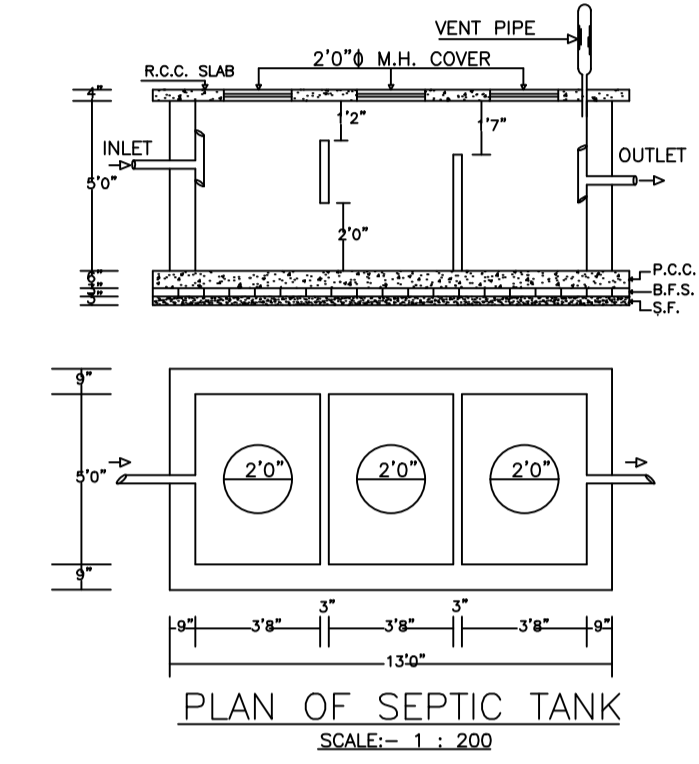
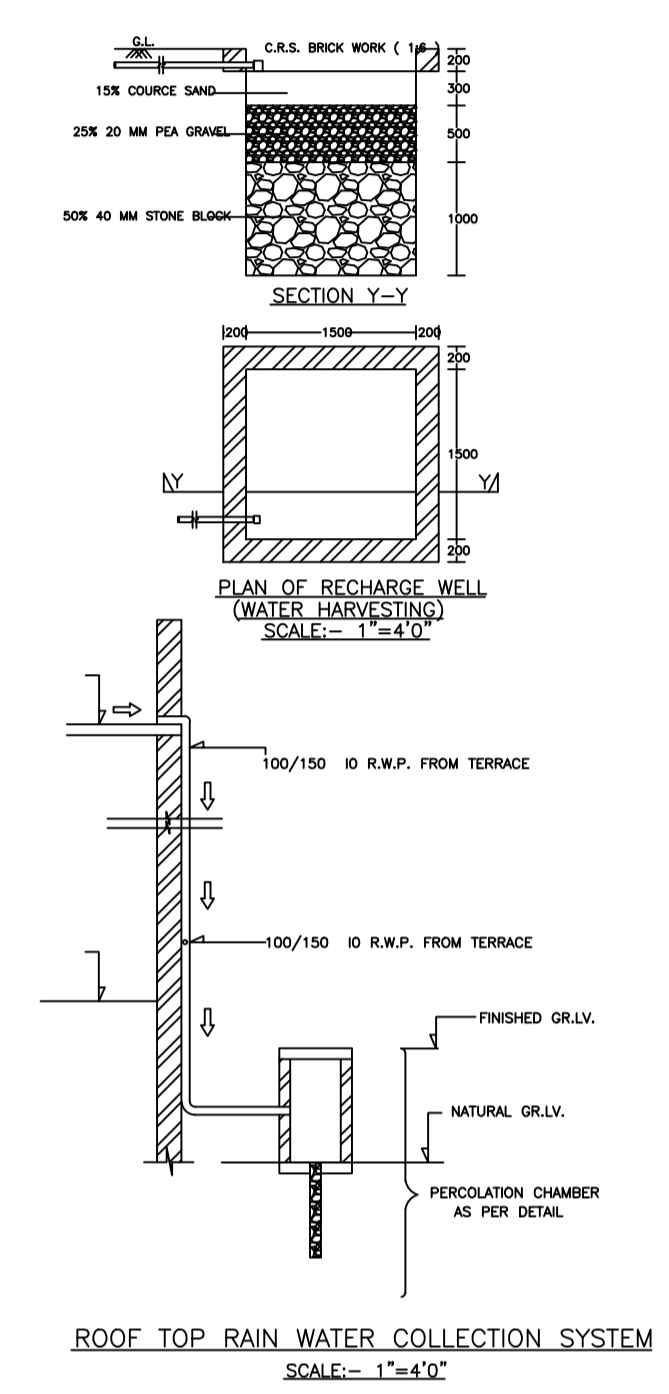
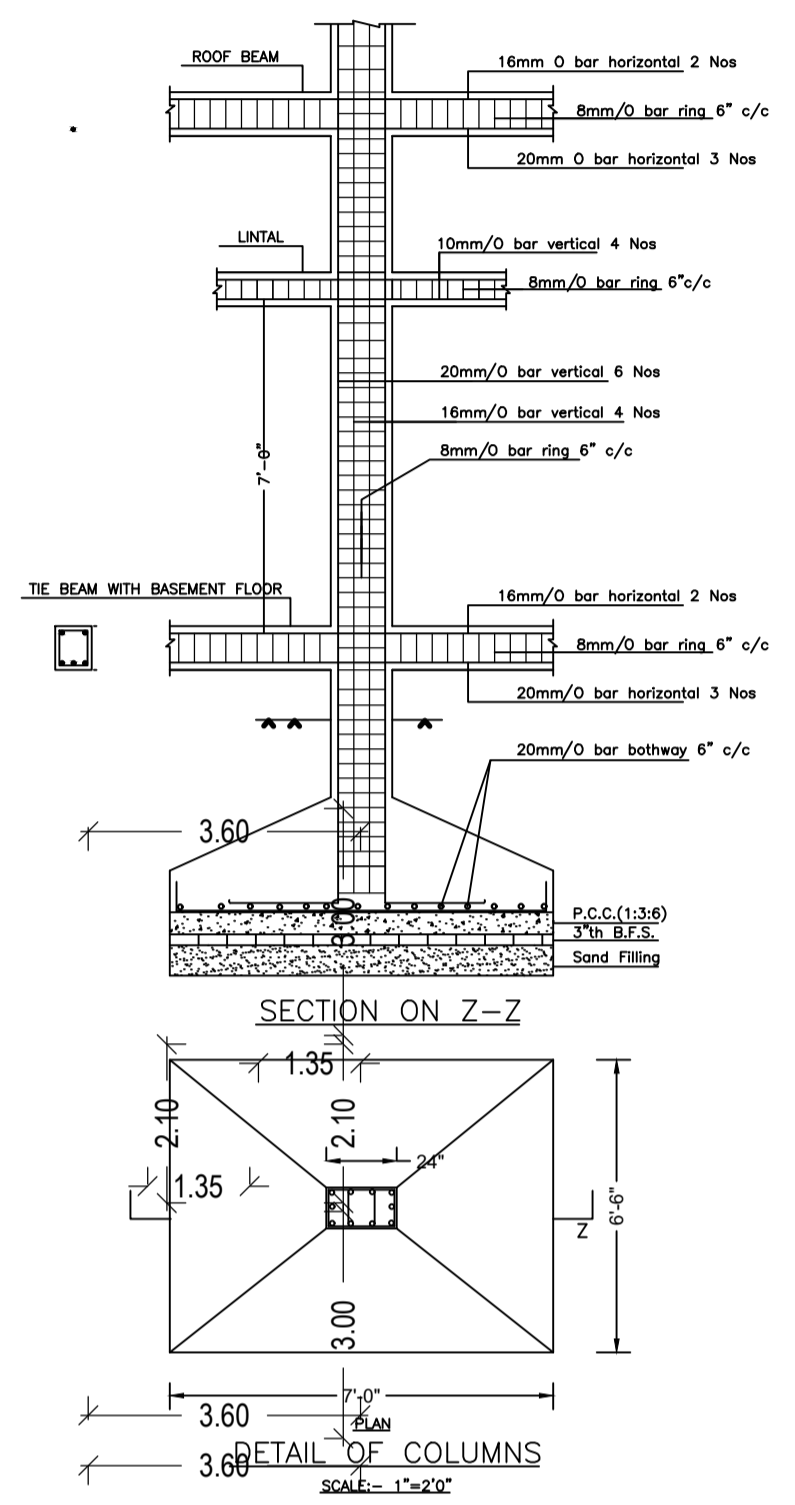
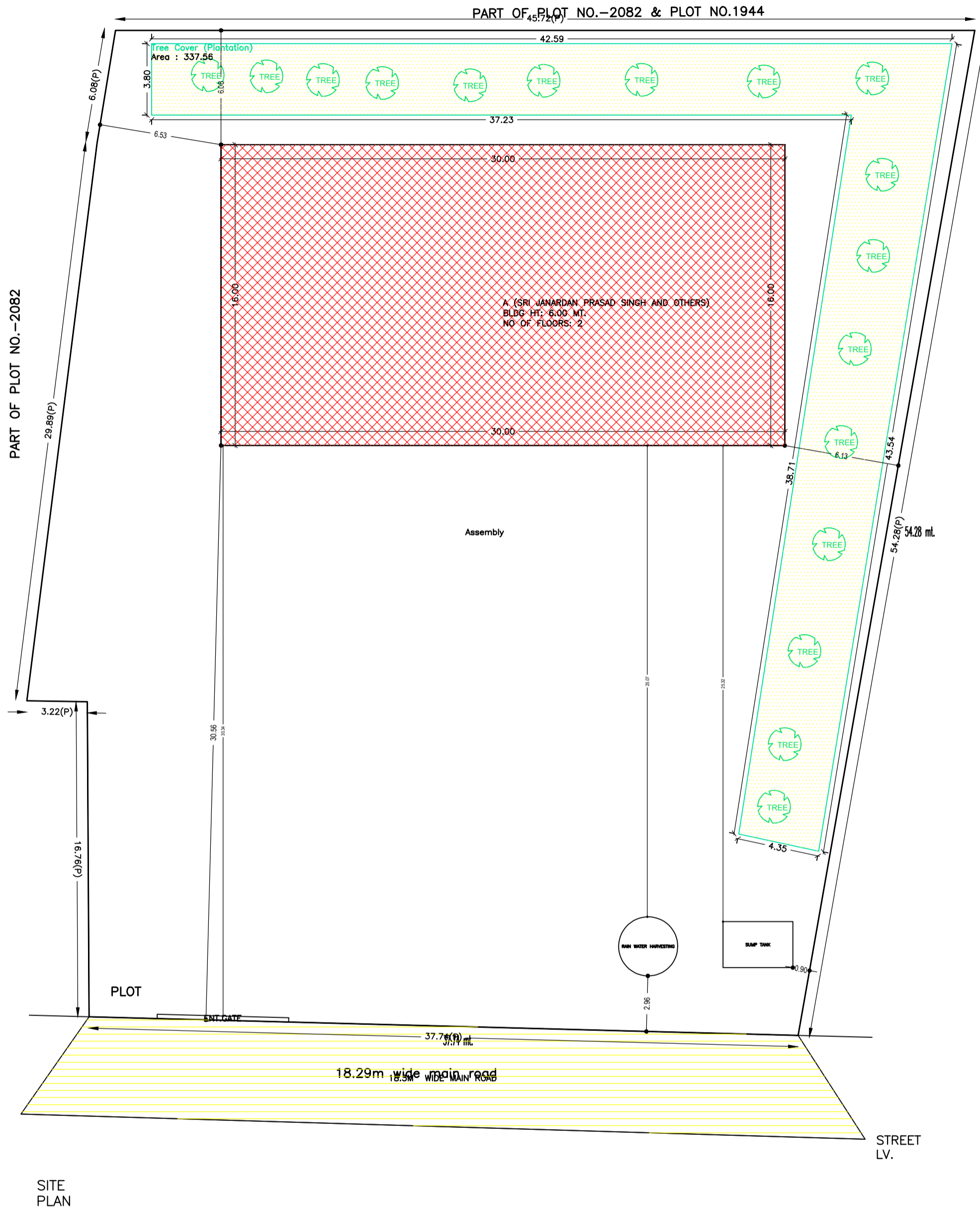

AREA STATEMENT	VERSION NO. : 1.0.37	SQ.MT.
DHANBAD MUNICIPAL CORPORATION	VERSION DATE: 29/04/2019	
PROJECT DETAIL:		
Region: JHARKHAND URBAN LOCAL BODIES	Plot Use: Assembly	
District: DHANBAD	Plot SubUse: Assembly Hall	
Authority: DHANBAD MUNICIPAL CORPORATION	PlotNearbyReligiousStructure: NA	
Inward No: DMC/BP/0054/W23/2017	Plot/SubPlot No: 2082 (P)	
Application Type: General Proposal	North: Road Width - 12.19	
Project Type: Building Permission	South: Plot No. - 2082	
Nature of Development: Revision	East: Plot No. - 2082	
Revise Case Type: Before 15th Sept 2004	West: Plot No. - Plot No.2082 & Plot No. 1944	
AREA DETAILS:		
AREA OF PLOT (Minimum)	(A)	2287.57
NET AREA OF PLOT(Gross Plot Area - Deduction from Gross Plot area)	(A-Deductions)	2287.57
Deduction for Balance Plot Area(from Gross Plot Area)		
Common Plot		337.56
Total		337.56
BALANCE AREA OF PLOT(Net Plot Area - Recreational/Amenity space)	(A-Deductions)	1950.02
PLOT AREA FOR COVERAGE(Net Plot Area)	(A-Deductions)	2287.57
Plot Area for FAR (Net Plot Area + RoadWidening Area)	(A-Deductions)	2287.57
COVERAGE CHECK		
Permissible Coverage area (50.00 %)		1143.79
Proposed Coverage Area (20.98 %)		480.00
Total Prop. Coverage Area (20.98 %)		480.00
Balance coverage area (29.02 %)		663.79
FAR CHECK		
Perm. FAR Area (2.25)		5147.03
Total Perm. FAR area		5147.03
Special FAR		871.06
Proposed FAR Area		886.90
Total Proposed FAR Area		886.90
Consumed FAR (Factor)		0.39
Balance FAR Area		4260.13
BUILT UP AREA CHECK		
Total Proposed BuiltUp Area		1354.97
ARCHITECT (Regd)		PIYUSH KANTI SINGH
ENGINEER (Regd)		
SUPERVISOR (Regd)		
OWNER (Regd)		Sri.Janardan Prasad Singh and Other's
DEVELOPMENT AUTHORITY		LOCAL BODY

COLOR INDEX	
PLOT BOUNDARY	Black
ABUTTING ROAD	Red
PROPOSED CONSTRUCTION	Green
COMMON PLOT	Yellow
ROAD WIDENING AREA	Orange
EXISTING (To be retained)	Blue
EXISTING (To be demolished)	Light Blue

Buildingwise Floor FAR Details

Floor Name	Building Name		Total	
	A (SRI JANARDAN PRASAD SINGH AND OTHERS)	Proposed FAR Area (Sq.mt.)	Total Proposed Built Up Area (Sq.mt.)	Total FAR Area (Sq.mt.)
Basement Floor	480.00	15.84	480.00	15.84
Ground Floor	480.00	480.00	480.00	480.00
First Floor	394.97	391.06	394.97	391.06
Terrace Floor	0.00	0.00	0.00	0.00
Total :	1354.97	886.90	1354.97	886.90

SCHEDULE OF DOOR:

BUILDING NAME	NAME	LENGTH	HEIGHT	NOS
A (SRI JANARDAN PRASAD SINGH AND OTHERS)	D3	0.75	2.10	14
A (SRI JANARDAN PRASAD SINGH AND OTHERS)	D2	0.90	2.10	04
A (SRI JANARDAN PRASAD SINGH AND OTHERS)	D1	1.00	2.10	16
A (SRI JANARDAN PRASAD SINGH AND OTHERS)	D	1.50	2.10	03

SCHEDULE OF WINDOW/VENTILATION:

BUILDING NAME	NAME	LENGTH	HEIGHT	NOS
A (SRI JANARDAN PRASAD SINGH AND OTHERS)	V	0.60	1.20	17
A (SRI JANARDAN PRASAD SINGH AND OTHERS)	W	1.20	1.20	41

Building :A (SRI JANARDAN PRASAD SINGH AND OTHERS)

Floor Name	Gross Builtup Area	Deductions From Gross BUA(Area in Sq.mt.)	Total Built Up Area (Sq.mt.)	Deductions (Area in Sq.mt.)	Proposed FAR Area (Sq.mt.)	Add Area In FAR (Sq.mt.)	Total FAR Area (Sq.mt.)	Total Consumed Additional FAR Area (Sq.mt.)	Tnmt (No.)
Basement Floor	480.00	0.00	480.00	0.00	464.16	0.00	15.84	15.84	00
Ground Floor	480.00	0.00	480.00	0.00	480.00	0.00	480.00	480.00	01
First Floor	480.00	85.03	394.97	3.91	0.00	391.06	391.06	391.06	01
Terrace Floor	0.00	0.00	0.00	0.00	0.00	0.00	0.00	0.00	00
Total :	1440.00	85.03	1354.97	3.91	464.16	871.06	15.84	886.90	02
Total Number of Same Buildings :	1								
Total :	1440.00	85.03	1354.97	3.91	464.16	871.06	15.84	886.90	02

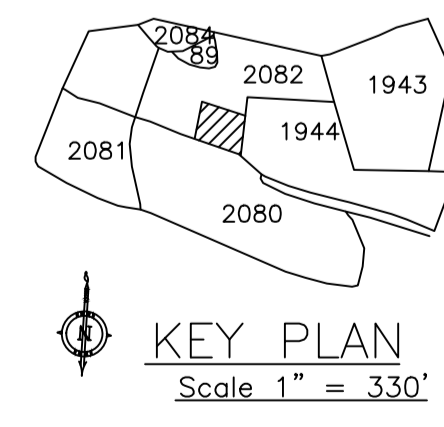
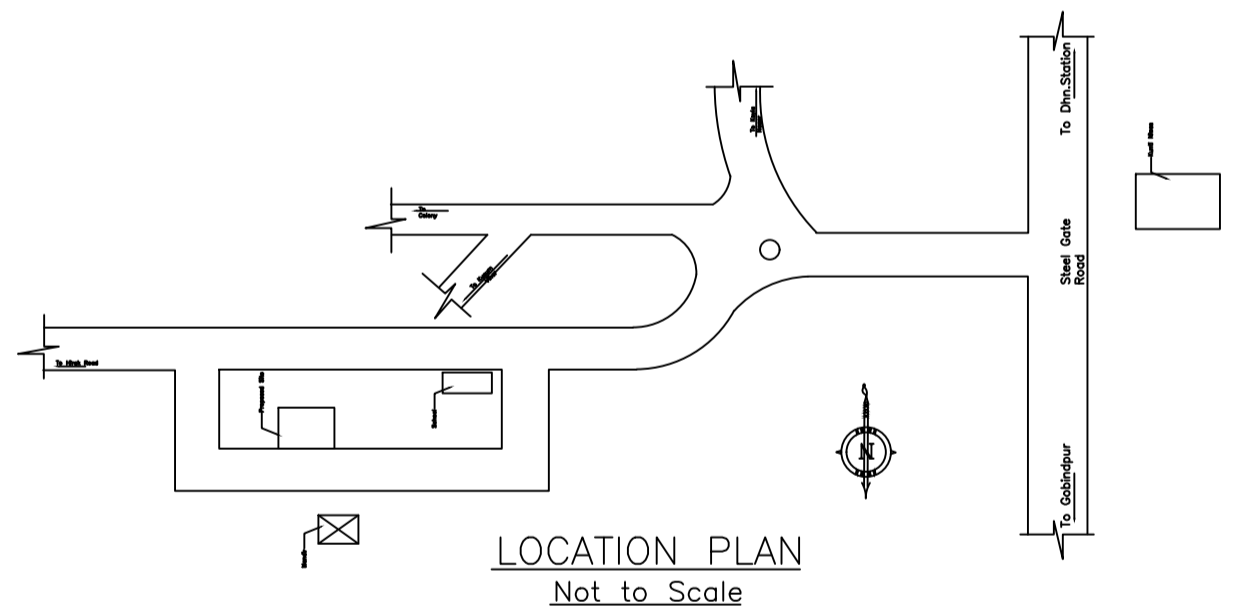

FAR & Tenement Details (Table 4c-1)

Building	No. of Same Bldg	Gross Built Up Area (Sq.mt.)	Deductions From Gross BUA(Area in Sq.mt.)	Total Built Up Area (Sq.mt.)		Proposed FAR Area (Sq.mt.)	Add Area In FAR (Sq.mt.)	Total FAR Area (Sq.mt.)	Total Consumed Additional FAR Area (Sq.mt.)	Tnmt (No.)	
				Balcony	Parking						
A (SRI JANARDAN PRASAD SINGH AND OTHERS)	1	1440.00	85.03	1354.97	3.91	464.16	871.06	15.84	886.90	886.90	02
Grand Total	1	1440.00	85.03	1354.97	3.91	464.16	871.06	15.84	886.90	886.90	02

Required Parking(Table 7a)

Building Name	Type	SubUse	Area (Sq.mt.)	Units		Car		Visitors Car		TwoWheeler	
				Reqd./Unit	Prop.	Reqd./Unit	Prop.	Reqd./Unit	Prop.	Reqd./Unit	Prop.
A (SRI JANARDAN PRASAD SINGH AND OTHERS)	Assembly	Assembly Hall	>0	10	-	1	1	-	-	-	-
			>0	10	-	-	-	-	-	1	-
Total :			-	-	-	1	8	-	0	7	0

Parking Check (Table 7b)

Vehicle Type	Reqd.		Prop.	
	No.	Area	No.	Area
Car	-	-	8	100.00
Total Car	1	12.50	8	100.00
Visitor's Car Parking	-	-	7	87.50
Total Visitor Parking	-	-	7	87.50
TwoWheeler	-	-	15	30.00
Total TwoWheeler	-	-	15	30.00
Other Parking	-	-	-	246.69
Total		12.50		581.69

Balcony Calculations Table

FLOOR	SIZE	AREA	TOTAL AREA
FIRST FLOOR PLAN	1.20 X 3.26 X 2 X 1	7.82	7.82
Total	-	-	7.82

Building USE/SUBUSE Details

Building Name	Building Use	Building SubUse	Building Structure
A (SRI JANARDAN PRASAD SINGH AND OTHERS)	Assembly	Assembly Hall	Non-Highrise

UnitBUA Table for Building :A (SRI JANARDAN PRASAD SINGH AND OTHERS)

FLOOR	Name	UnitBUA Type	UnitBUA Area	Carpent Area	No. of Rooms	No. of Tenement
GROUND FLOOR PLAN	GF	OTHER	480.00	471.32	3	1
FIRST FLOOR PLAN	FF	OTHER	394.97	386.64	30	1
Total	-	-	874.97	857.96	33	2

Proposal Basic Information	
Proposal File No.	DMC/BP/0054/W23/2017
Owner Name	Sri.Janardan Prasad Singh and Other's
Khata No	41
Plot No	2082 (P)
Village Name	Kolakusma
Use	Assembly
SubUse	Assembly Hall

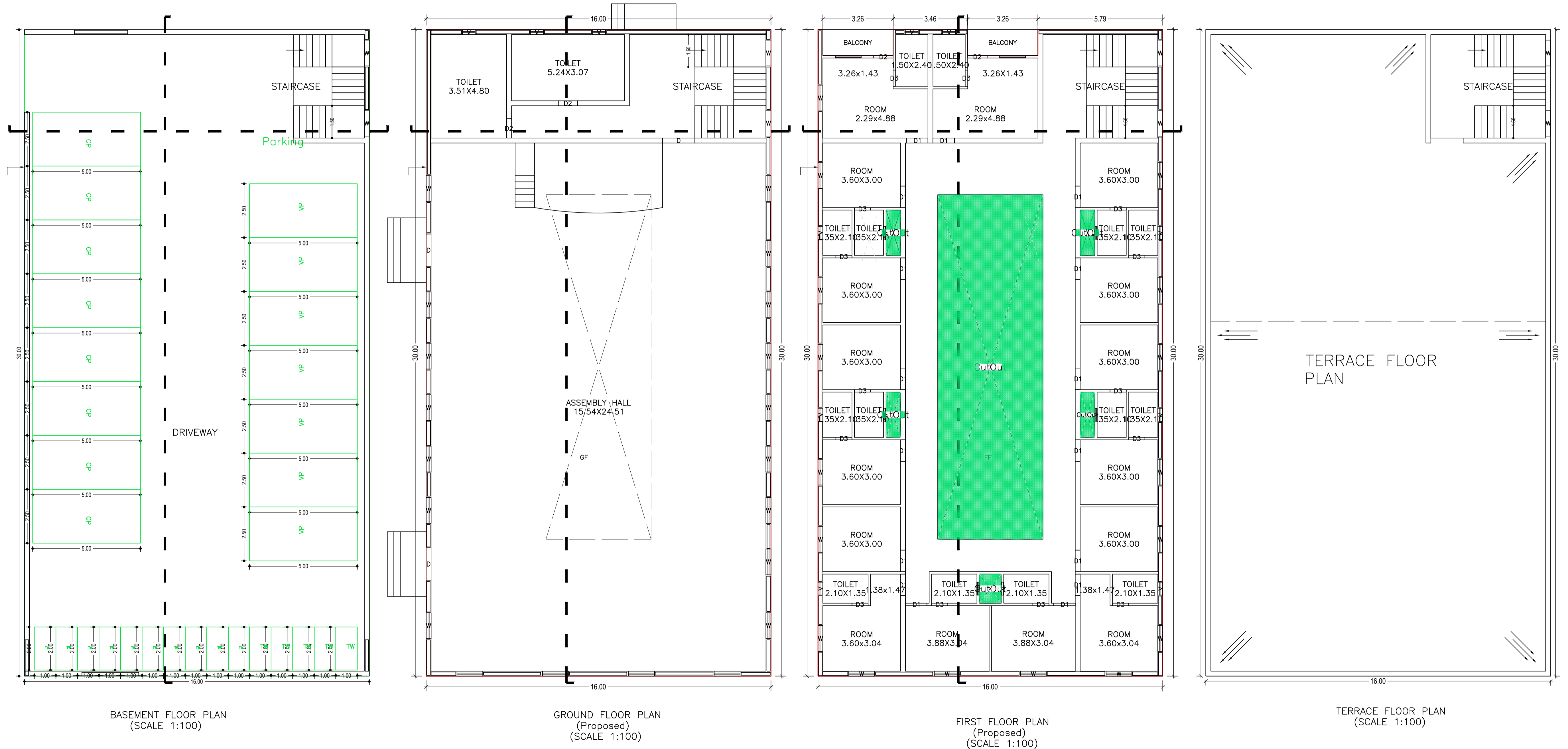

LTP NAME AND SIGNATURE	STRUCTURAL ENG'S NAME AND SIGNATURE	BUILDER NAME AND SIGNATURE	DIGITAL SIGNATURE
PIYUSH KANTI SINGH DMC/ENG/0020/2016			

Proposal Basic Information	
Proposal File No.	DMC/BP/0054/W23/2017
Owner Name	Sri.Janardan Prasad Singh and Other's
Khata No	41
Plot No	2082 (P)
Village Name	Kolakusma
Use	Assembly
SubUse	Assembly Hall

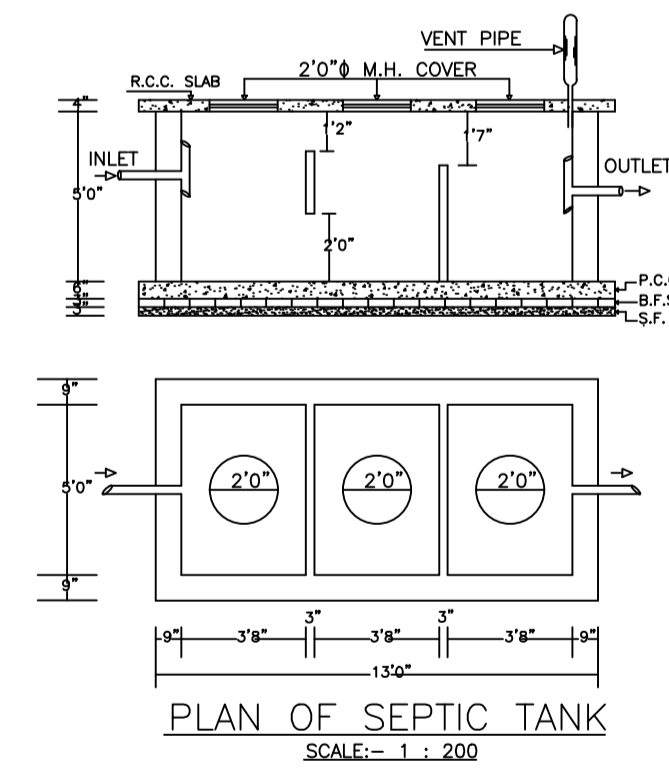
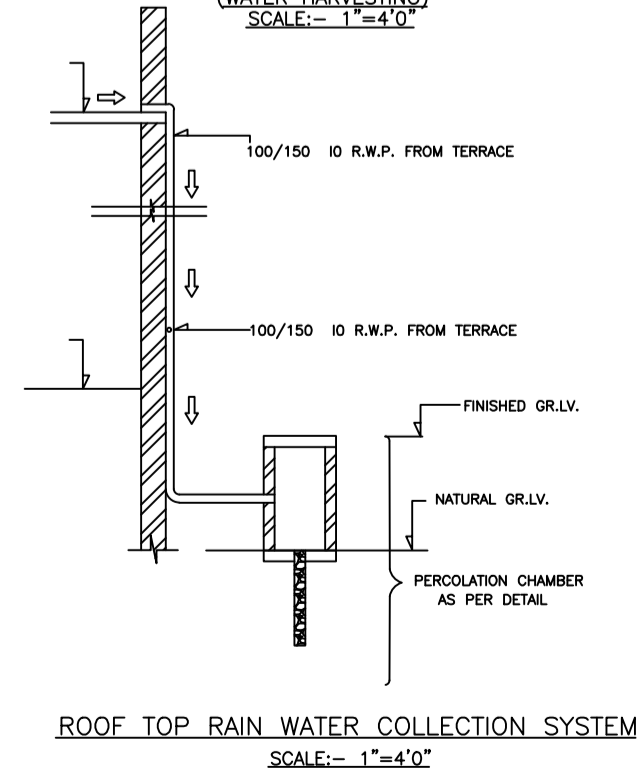
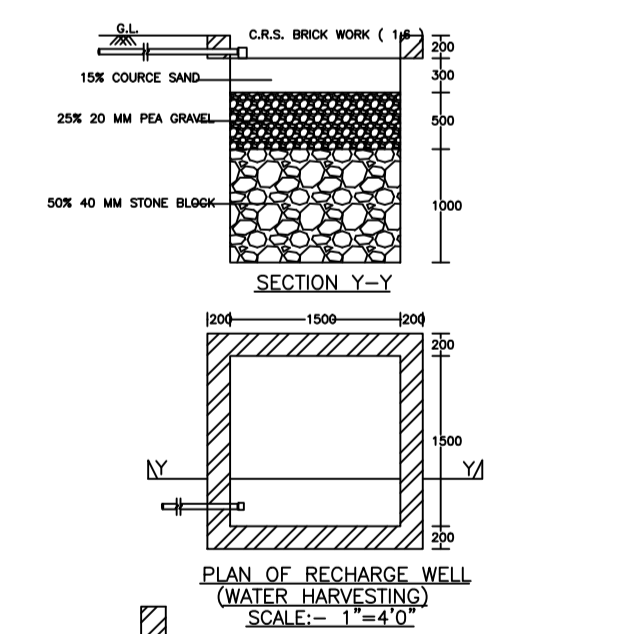
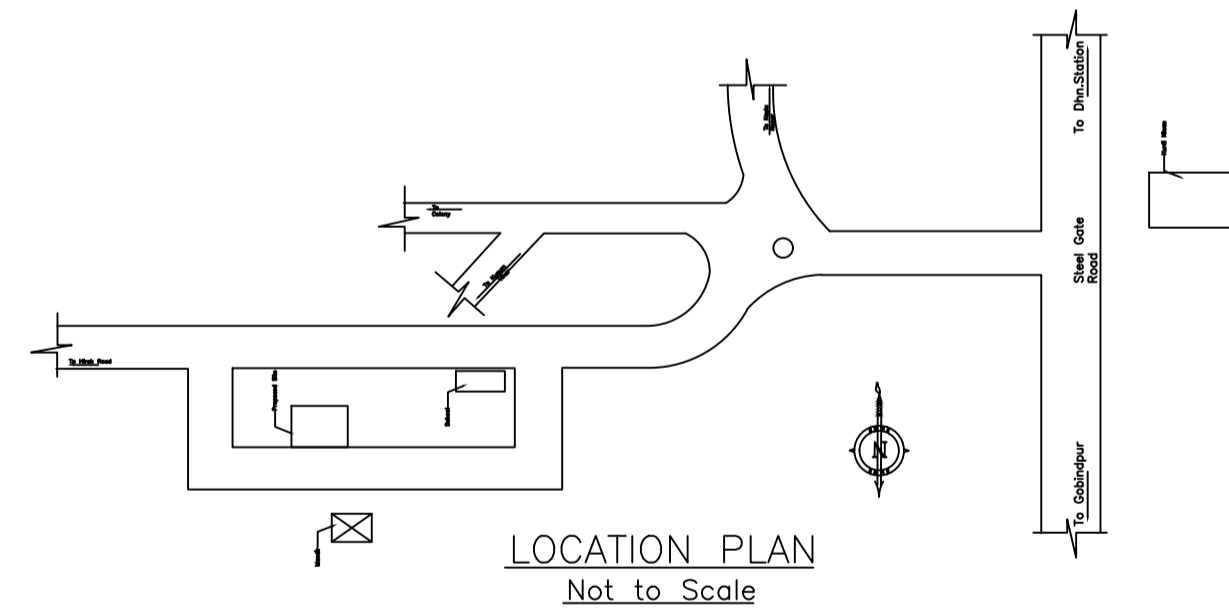
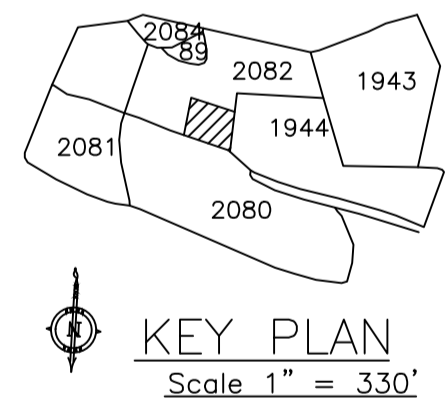
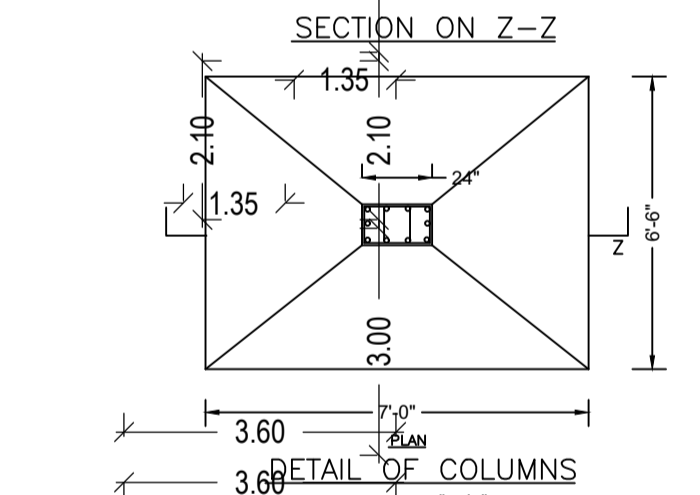
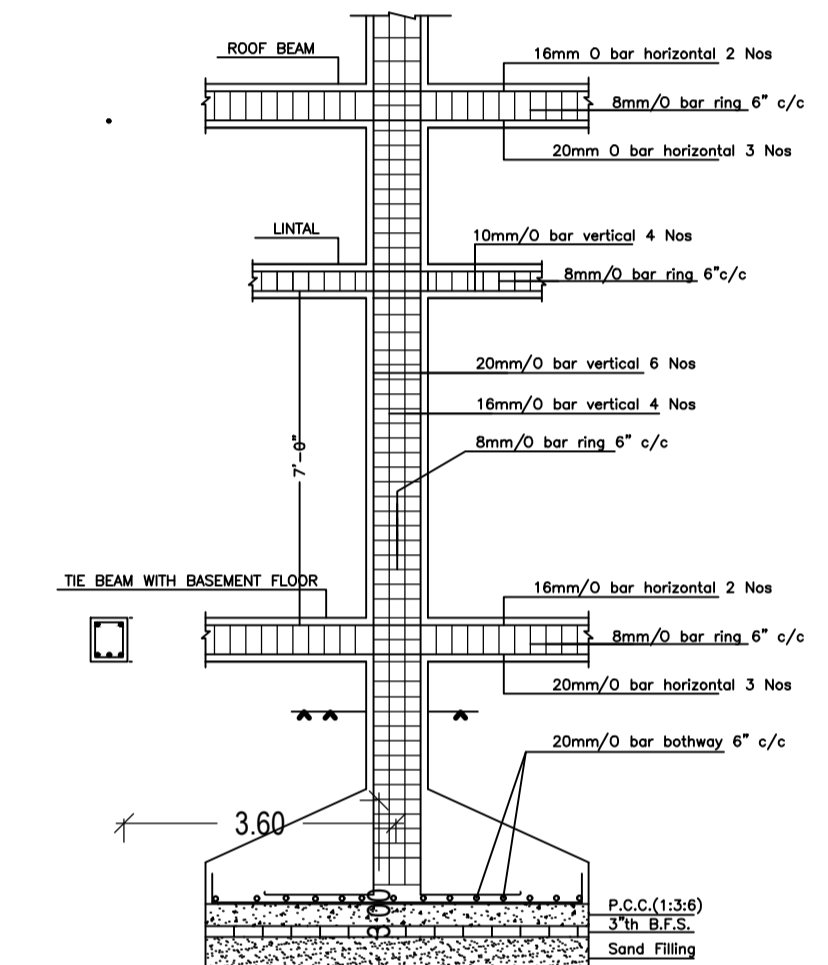
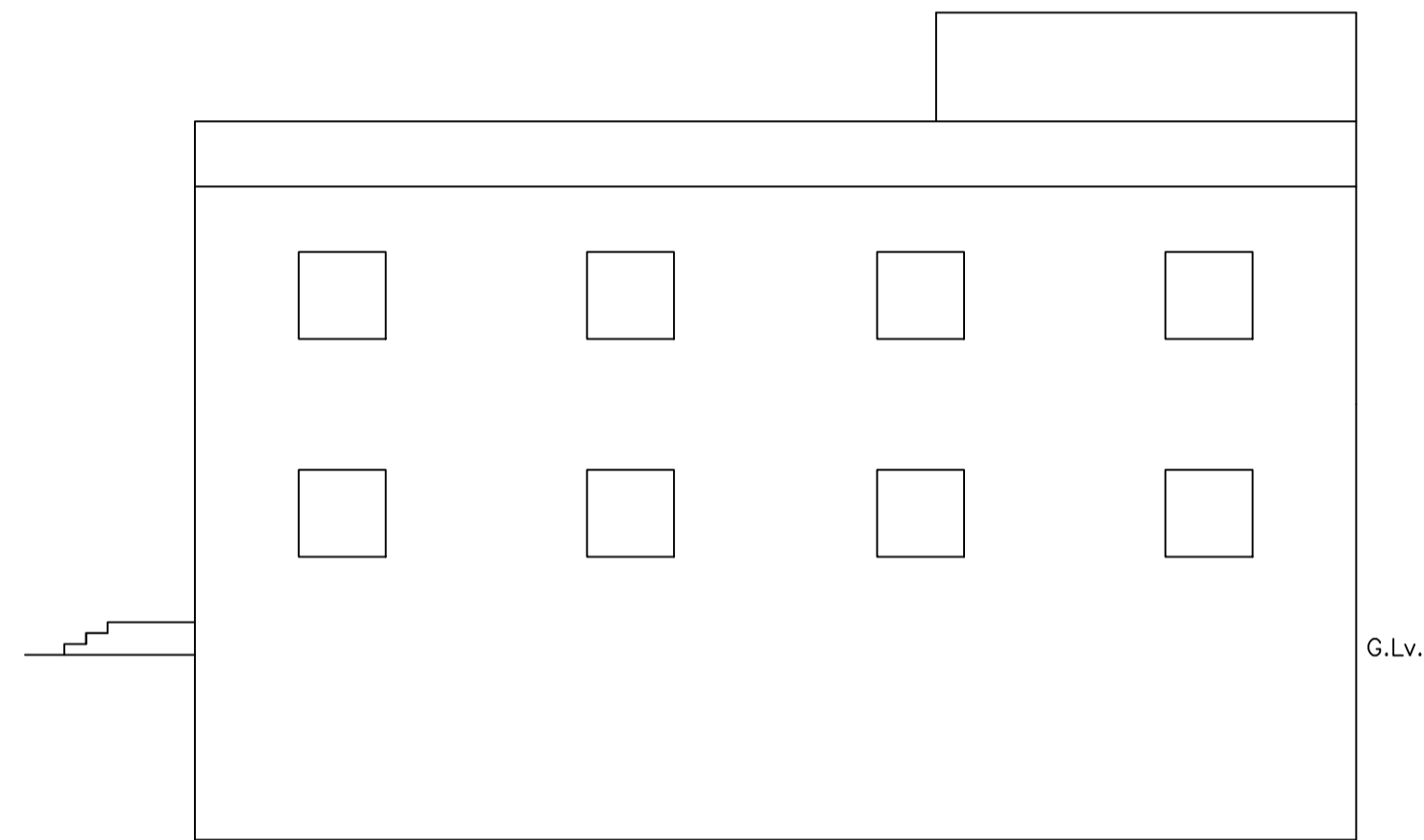
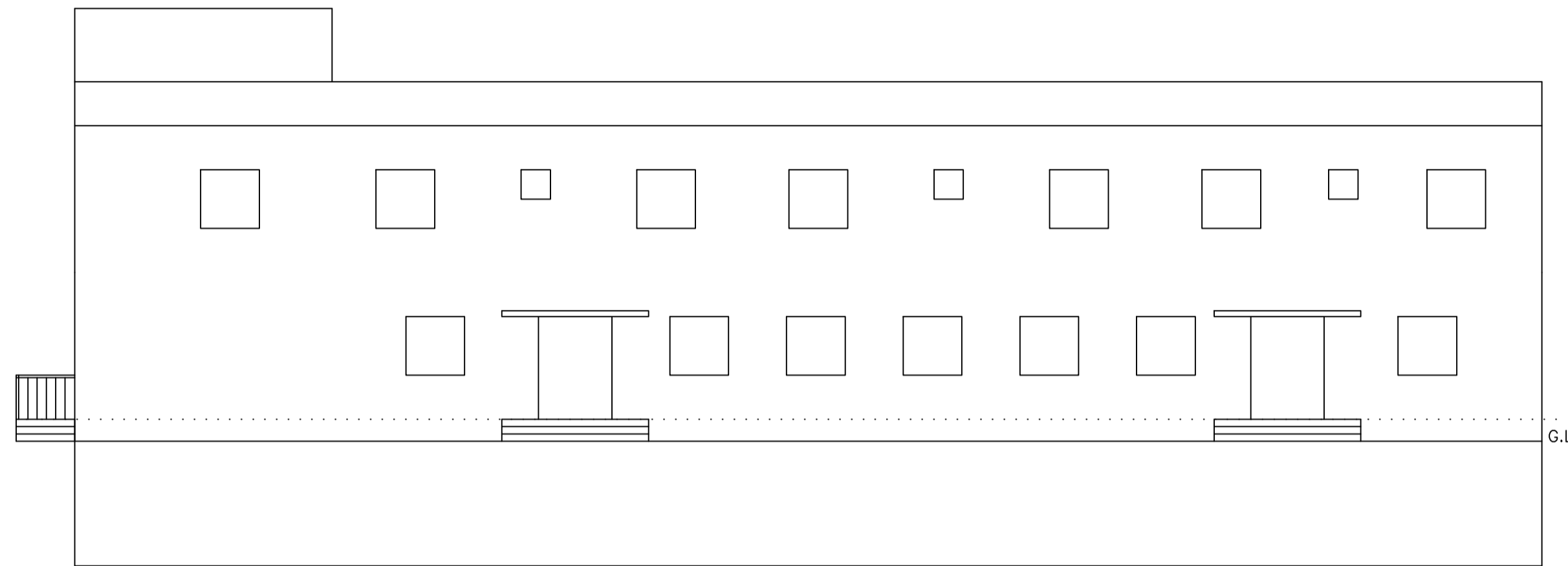
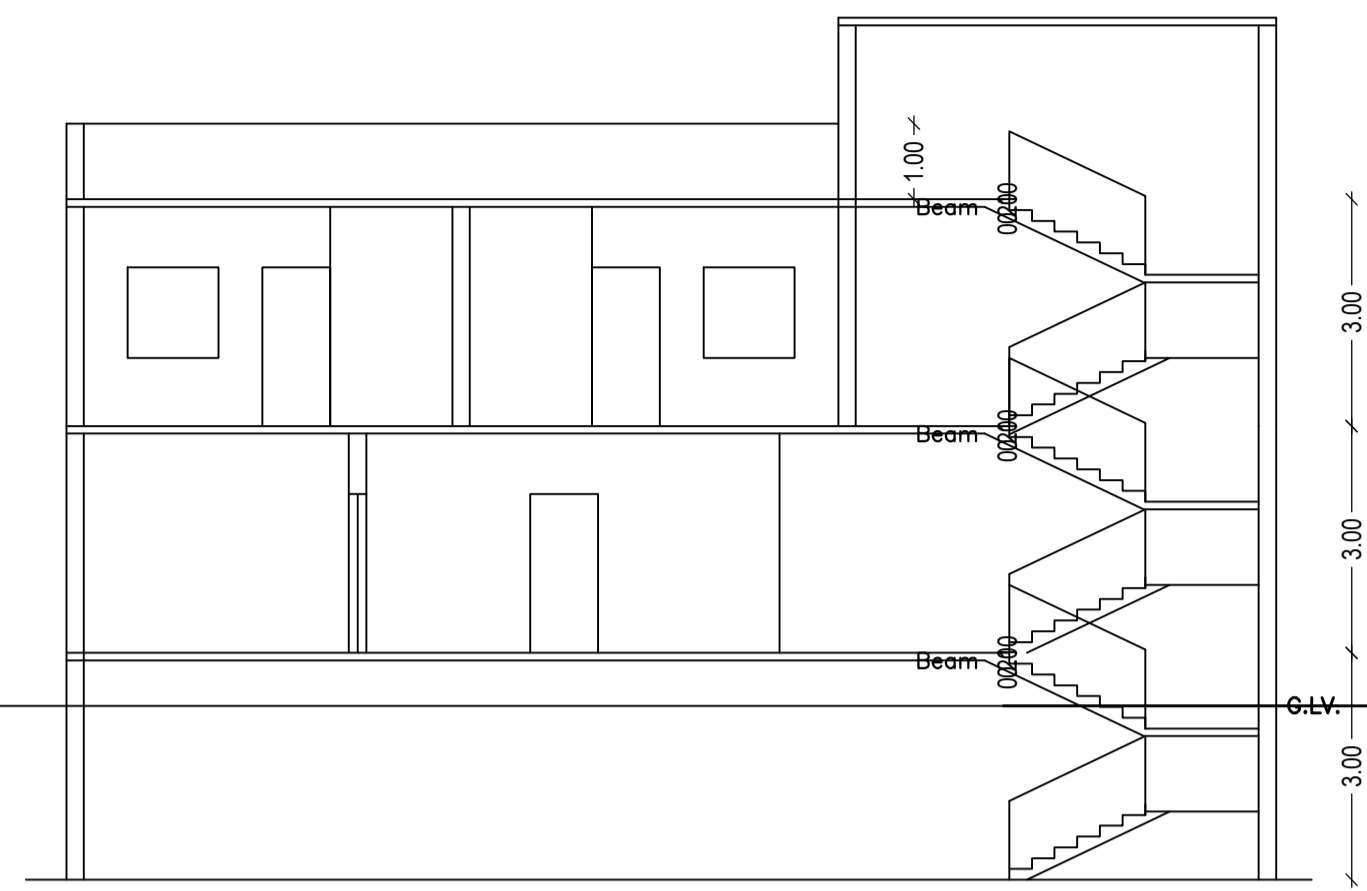
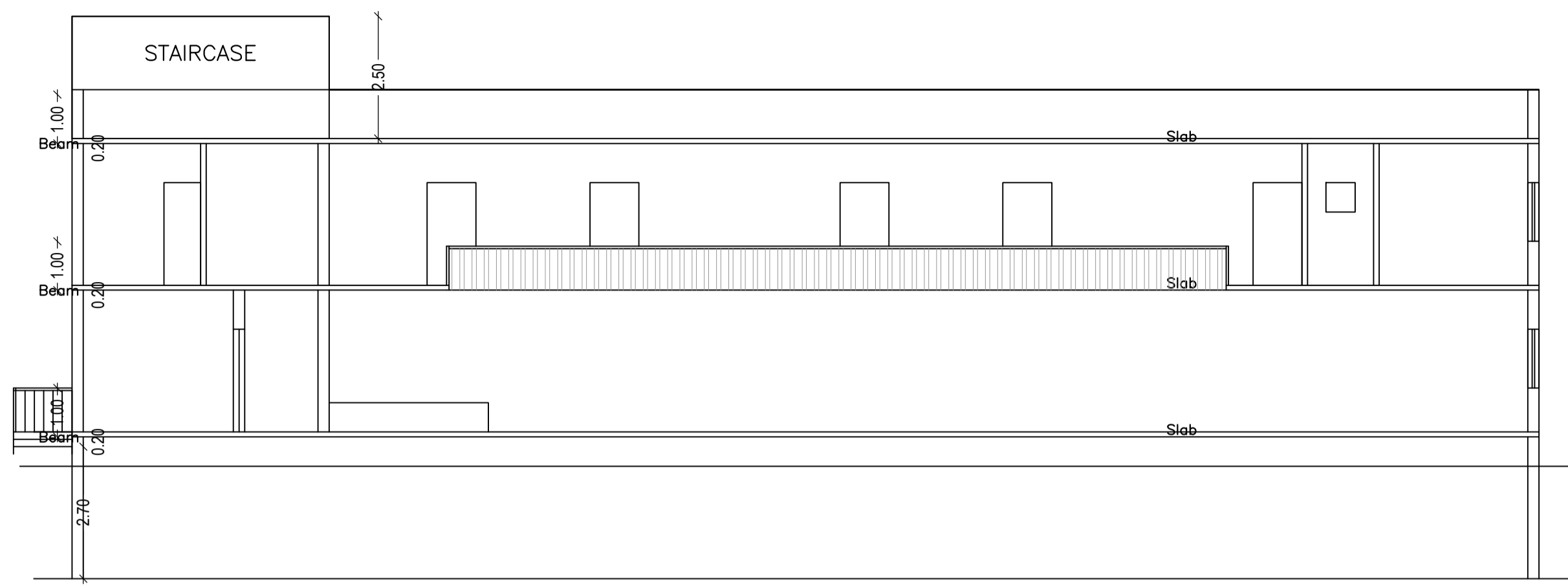

LTP NAME AND SIGNATURE	STRUCTURAL ENG'S NAME AND SIGNATURE	BUILDER NAME AND SIGNATURE	DIGITAL SIGNATURE
PIYUSH KANTI SINGH DMC/ENG/0020/2016			