

SITE PLAN

SITE PLAN

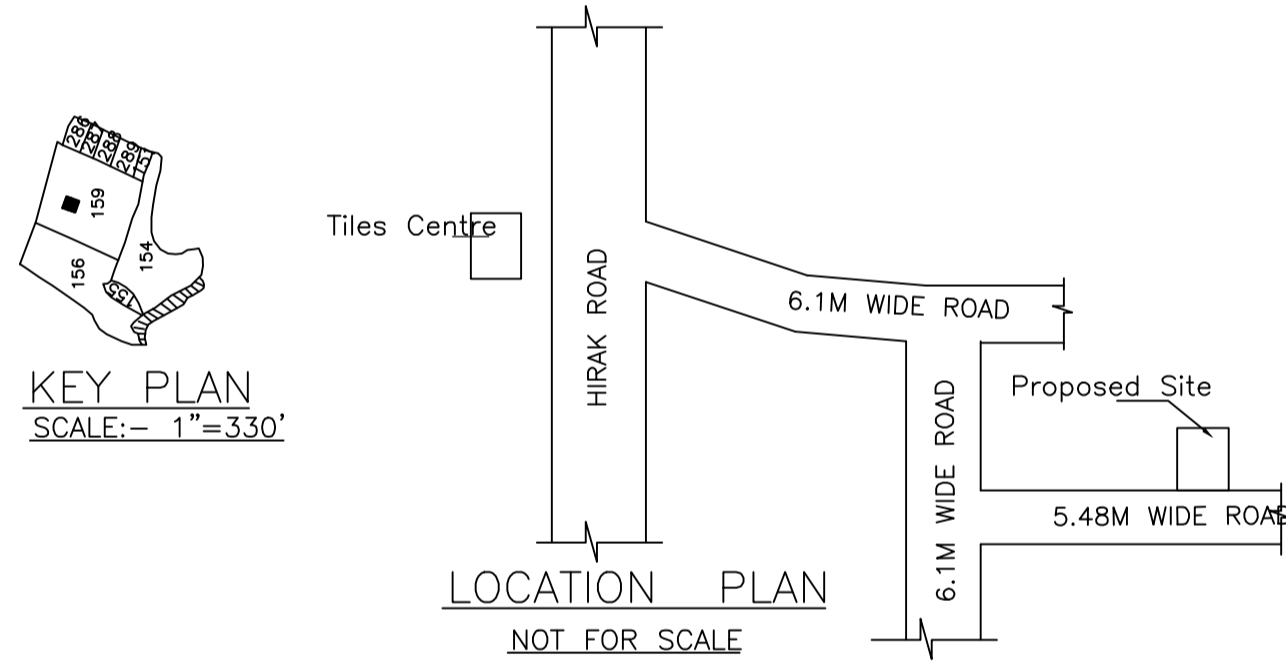

LOCATION PLAN  
NOT FOR SCALE

SCHEDULE OF DOOR:

BUILDING NAME	NAME	LENGTH	HEIGHT	NOS
A (SMT SUNAINA DEVI)	D2	0.75	2.10	05
A (SMT SUNAINA DEVI)	D1	0.90	2.10	02
A (SMT SUNAINA DEVI)	D	1.00	2.10	07

SCHEDULE OF WINDOW/VENTILATION:

BUILDING NAME	NAME	LENGTH	HEIGHT	NOS
A (SMT SUNAINA DEVI)	V	0.60	1.20	05
A (SMT SUNAINA DEVI)	W	1.20	1.20	14

Building :A (SMT SUNAINA DEVI)

Floor Name	Total Built Up Area (Sq.mt.)	Deductions (Area in Sq.mt.)	Total Consumed Additional FAR Area (Sq.mt.)	Trmt (No.)
Ground Floor	102.35	89.61	89.61	01
First Floor	0.00	89.61	89.61	00
Terrace Floor	0.00	0.00	0.00	00
Total:	191.96	12.74	179.22	01
Total Number of Same Buildings	1			
Total:	191.96	12.74	179.22	01

UnitBUA Table for Building :A (SMT SUNAINA DEVI)

FLOOR	Name	UnitBUA Type	UnitBUA Area	Carpet Area	No. of Rooms	No. of Tenement
GROUND FLOOR PLAN	SPLIT 1	FLAT	179.21	178.69	7	1
FIRST FLOOR PLAN	SPLIT 1	FLAT	0.00	0.00	6	0
Total:	-	-	179.21	178.69	13	1

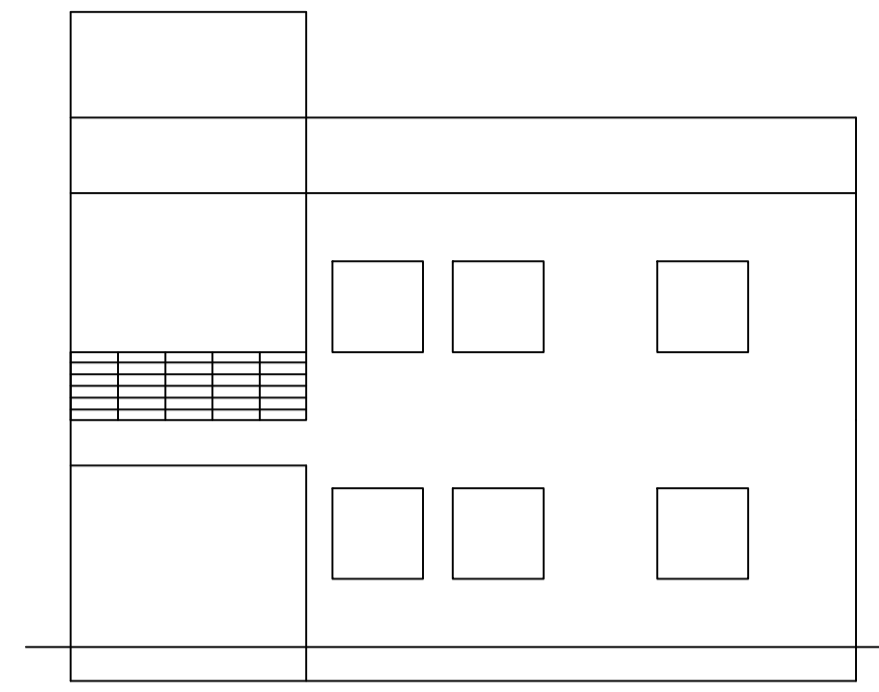

FRONT ELEVATION

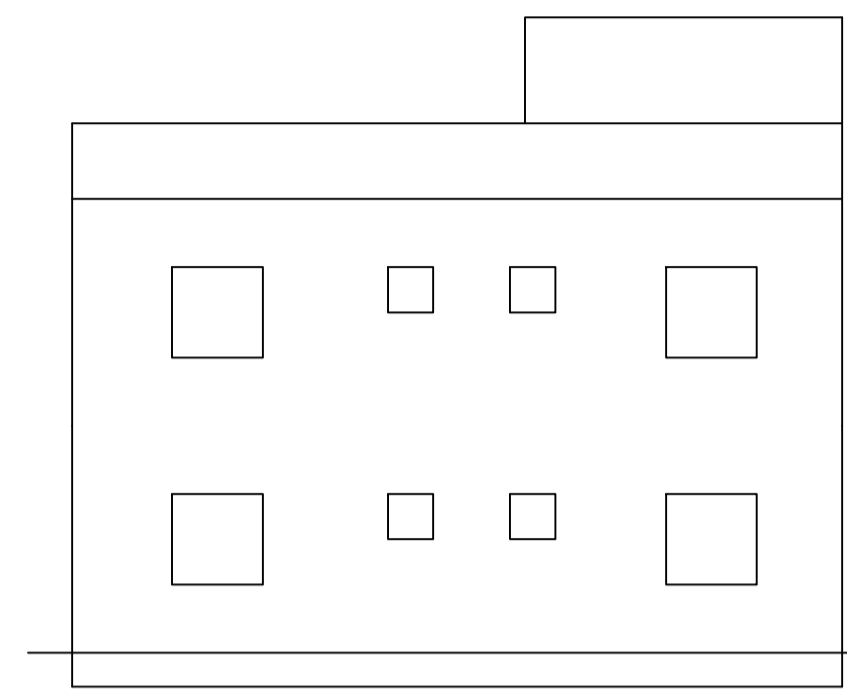

RIGHT SIDE ELEVATION

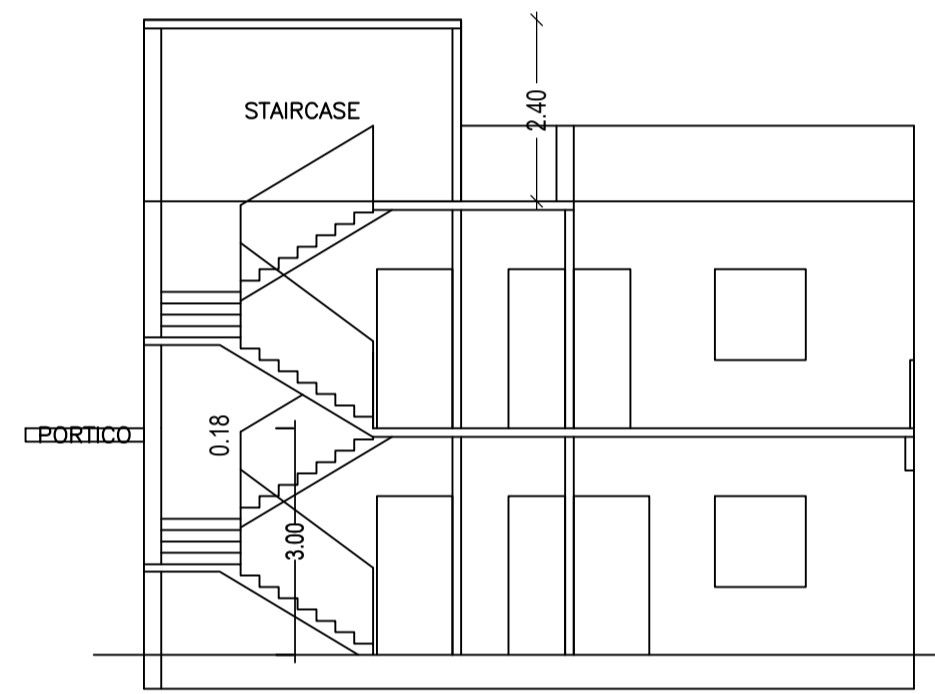

SECTION ON A-A

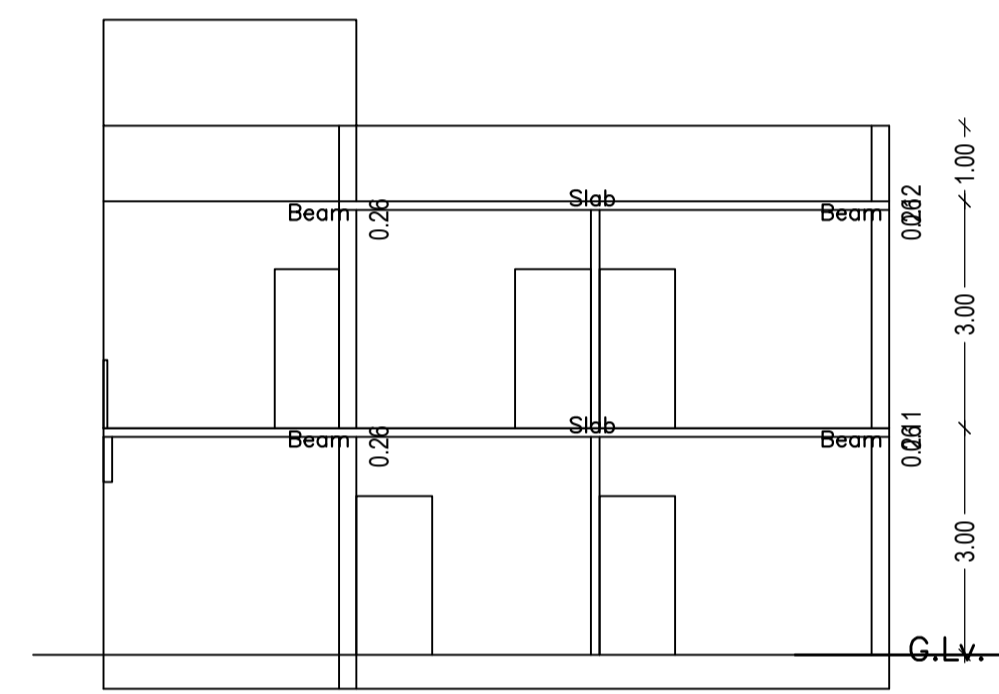

SECTION ON X-X

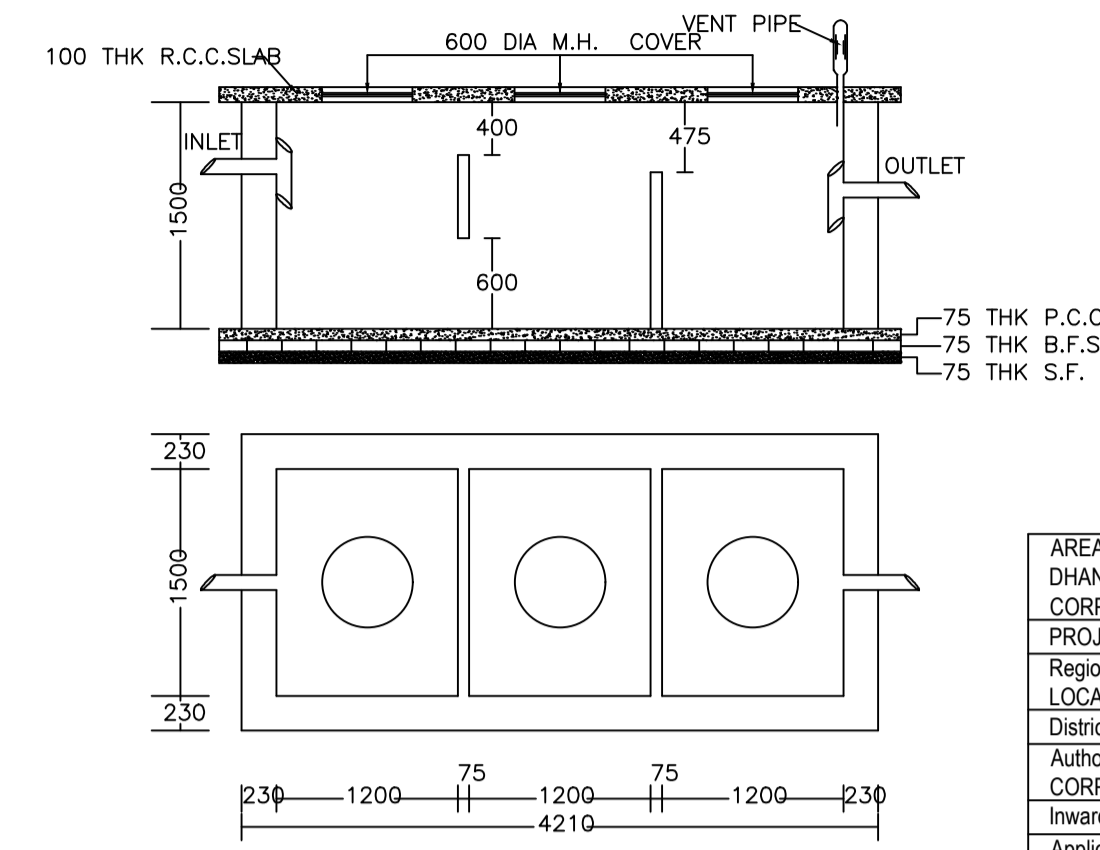

PLAN OF SEPTIC TANK

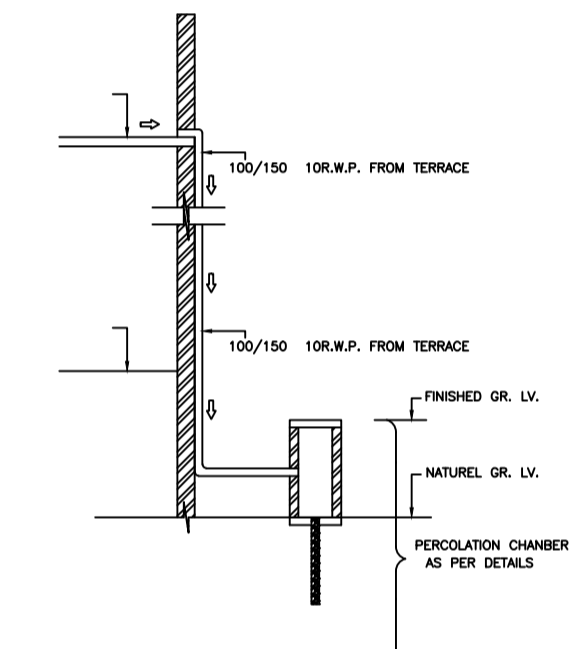

ROOF TOP RAIN WATER COLLECTION SYSTEM

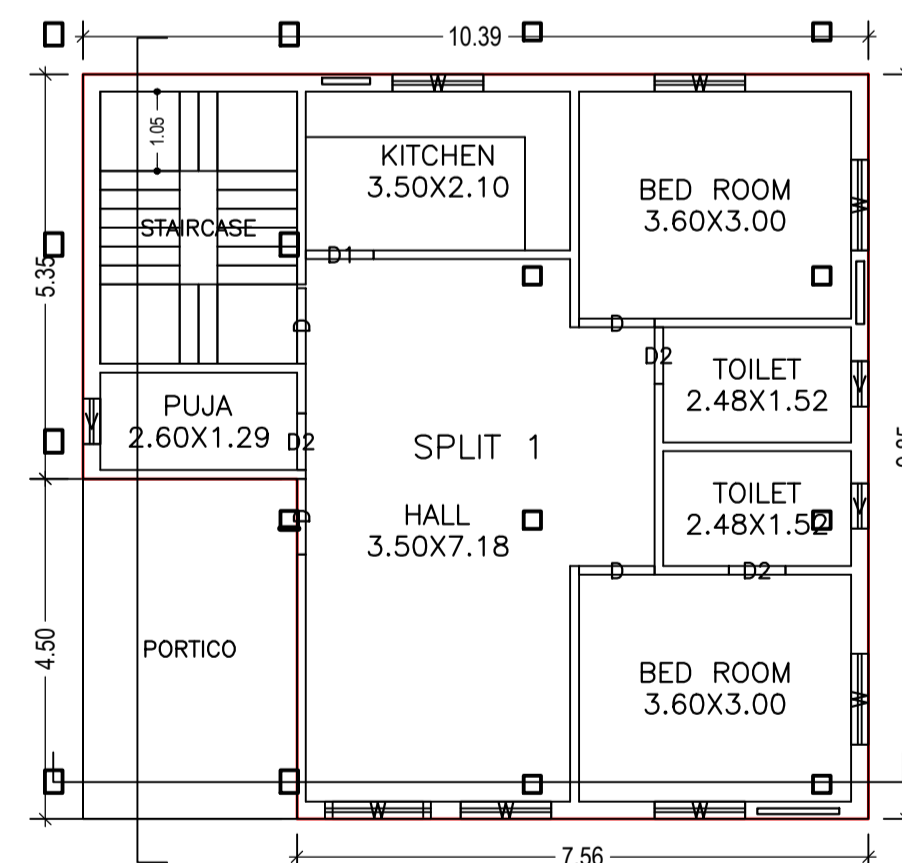

GROUND FLOOR PLAN  
(Proposed)  
(SCALE 1:100)

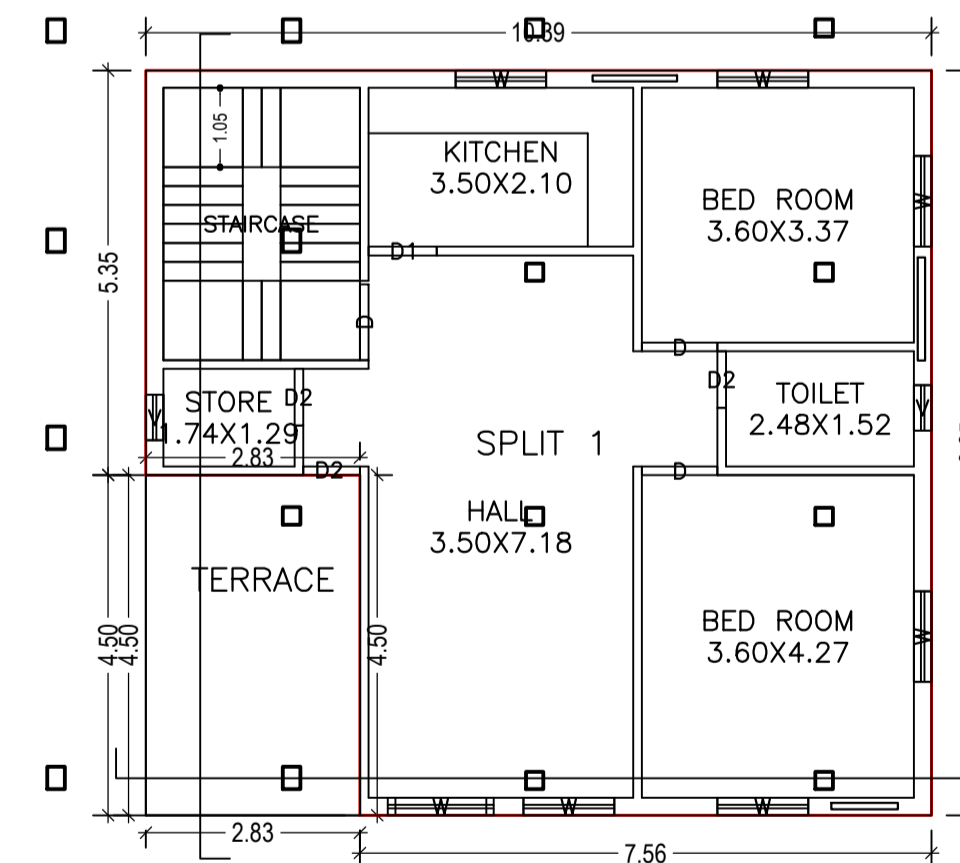

FIRST FLOOR PLAN  
(Proposed)  
(SCALE 1:100)

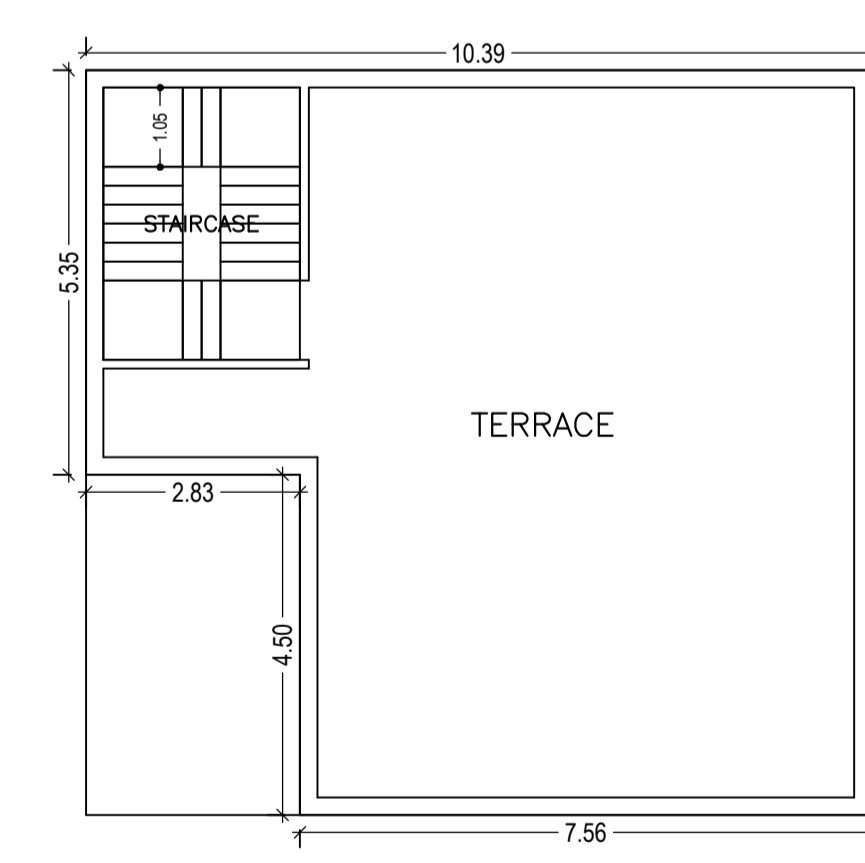

TERRACE FLOOR PLAN  
(SCALE 1:100)

AREA STATEMENT		VERSION NO.:	1.0.42
DHANBAD MUNICIPAL CORPORATION		VERSION DATE: 29/04/2019	
PROJECT DETAIL:			
Region: JHARKHAND URBAN LOCAL BODIES	Plot Use: Residential		
District: DHANBAD	Plot SubUse: Bungalow/ Dwelling / Non Apartment		
Authority: DHANBAD MUNICIPAL CORPORATION	Plot/Nearby/Religious/Structure: NA		
Inward No: DMC/BP/0317/W23/2019	Plot/SubPlot No: 123, NEW-159		
Application Type: General Proposal	North: Plot No. - 159		
Project Type: Building Permission	South: Plot No. - SHEEMA DEVI		
Nature of Development: New	East: Plot No. - 159		
Location of Development Area: Old Area	West: Road Width - 5.48		
AREA DETAILS:			
AREA OF PLOT (Minimum)	(A)	SQ.MT.	162.74
NET AREA OF PLOT (Gross Plot Area - Deduction from Gross Plot area)	(A-Deductions)		162.74
Deduction for Balance Plot Area (from Gross Plot Area)			
Common Plot			17.73
Total			17.73
BALANCE AREA OF PLOT (Net Plot Area - Recreational/Amenity space)	(A-Deductions)		145.01
PLOT AREA FOR COVERAGE (Net Plot Area)	(A-Deductions)		162.74
Plot Area for FAR (Net Plot Area + Road Widening Area)	(A-Deductions)		162.74
COVERAGE CHECK			
Permissible Coverage area ( 70.00 % )			113.92
Proposed Coverage Area ( 55.06 % )			89.61
Total Prop. Coverage Area ( 55.06 % )			89.61
Balance coverage area ( 14.94 % )			24.31
FAR CHECK			
Perm. FAR Area ( 1.80 )			292.93
Total Perm. FAR area			292.93
Residential FAR			179.21
Proposed FAR Area			179.21
Total Proposed FAR Area			179.21
Consumed FAR (Factor)			1.10
Balance FAR Area			113.72
BUILT UP AREA CHECK			
Total Proposed BuiltUp Area			191.96
ARCHITECT (Regd)		RAJEEV RANJAN SINGH	
ENGINEER (Regd)			
SUPERVISOR (Regd)			
OWNER (Regd)		SMT SUNAINA DEVI	
DEVELOPMENT AUTHORITY		LOCAL BODY	

COLOR INDEX	
PLOT BOUNDARY	Black
ABUTTING ROAD	Green
PROPOSED CONSTRUCTION	Red
COMMON PLOT	Yellow
ROAD WIDENING AREA	Blue
EXISTING (To be retained)	Orange
EXISTING (To be demolished)	Grey

Buildingwise Floor FAR Details

Floor Name	Building Name		Total	
	A (SMT SUNAINA DEVI)		Total Proposed Built Up Area (Sq.mt.)	Total FAR Area (Sq.mt.)
Ground Floor	102.35	89.61	102.35	89.61
First Floor	89.61	89.61	89.61	89.61
Terrace Floor	0.00	0.00	0.00	0.00
Total:	191.96	179.22	191.96	179.22

Building USE/SUBUSE Details

Building Name	Building Use	Building SubUse	Building Structure
A (SMT SUNAINA DEVI)	Residential	Bungalow/ Dwelling / Non Apartment	Non-Highrise

FAR & Tenement Details (Table 4c-1)

	No. of Same Bldg	Deductions (Area in Sq.mt.)	Proposed FAR Area (Sq.mt.)		Total FAR Area (Sq.mt.)	Total Consumed Additional FAR Area (Sq.mt.)	Trmt (No.)
			Archi.Proj.	Resi.			
A (SMT SUNAINA DEVI)	1	191.96	12.74	179.22	179.22	179.22	01
Grand Total:	1	191.96	12.74	179.22	179.22	179.22	01

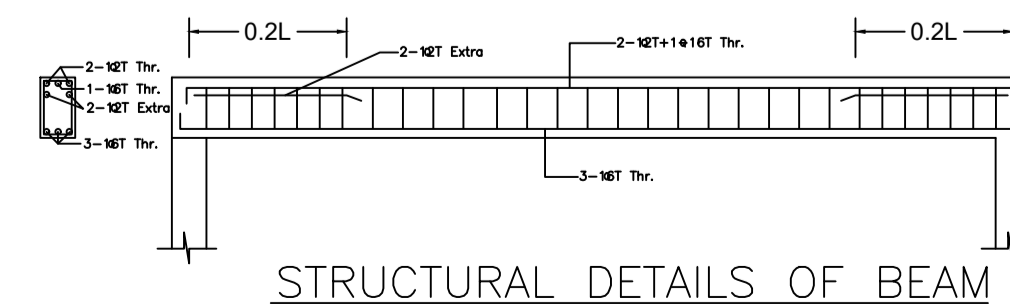

STRUCTURAL DETAILS OF BEAM

LTP NAME AND SIGNATURE	STRUCTURAL ENG'S NAME AND SIGNATURE	BUILDER NAME AND SIGNATURE	DIGITAL SIGNATURE
RAJEEV RANJAN SINGH DMC/ENG/0032/2017			

Proposal Basic Information	
Proposal File No.	DMC/BP/0317/W23/2019
Owner Name	SMT SUNAINA DEVI
Khata No	11, NEW-02
Plot No	123, NEW-159
Village Name	Bhelaland
Use	Residential
SubUse	Bungalow/ Dwelling / Non Apartment

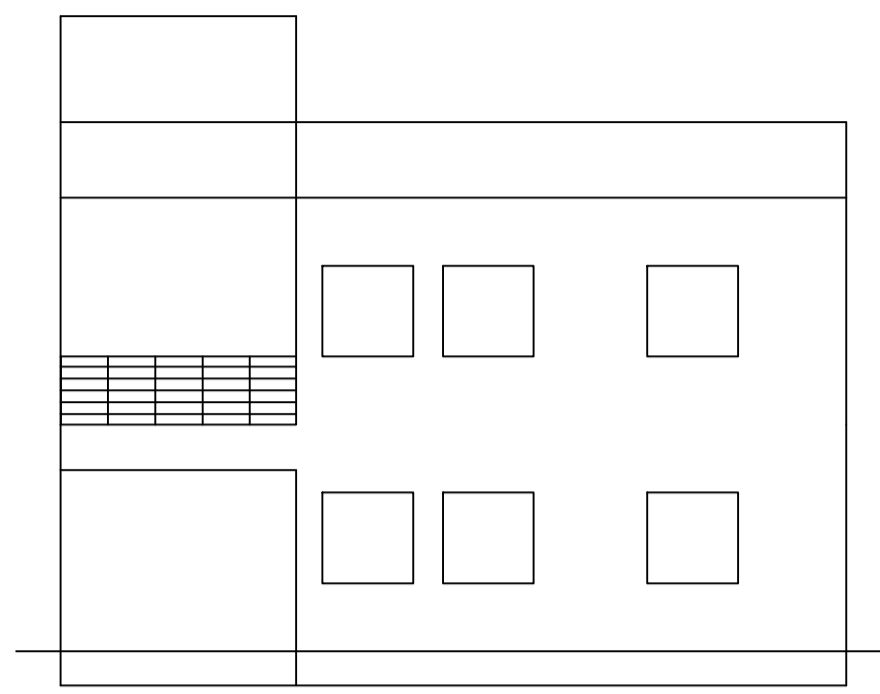

FRONT ELEVATION

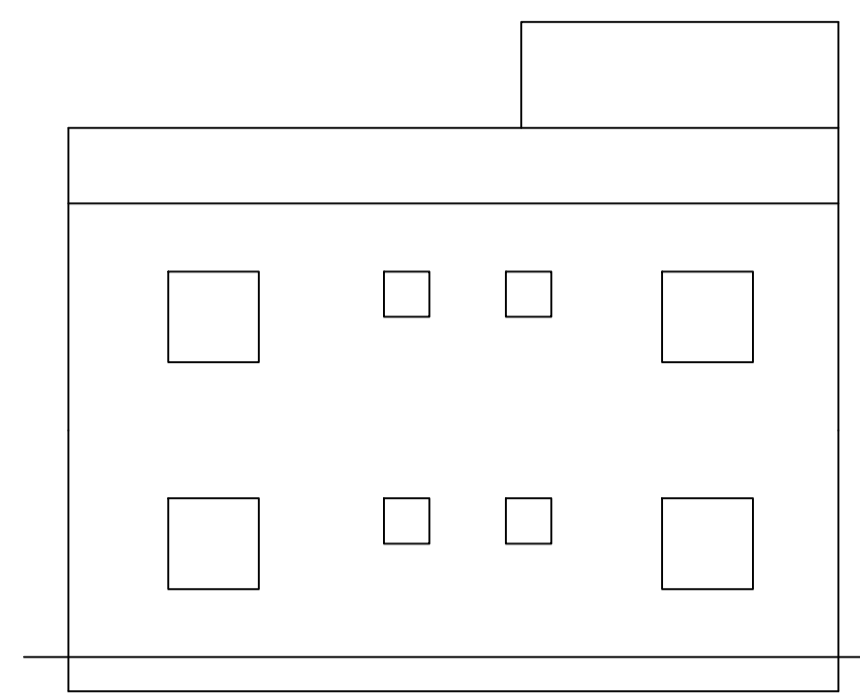

RIGHT SIDE ELEVATION

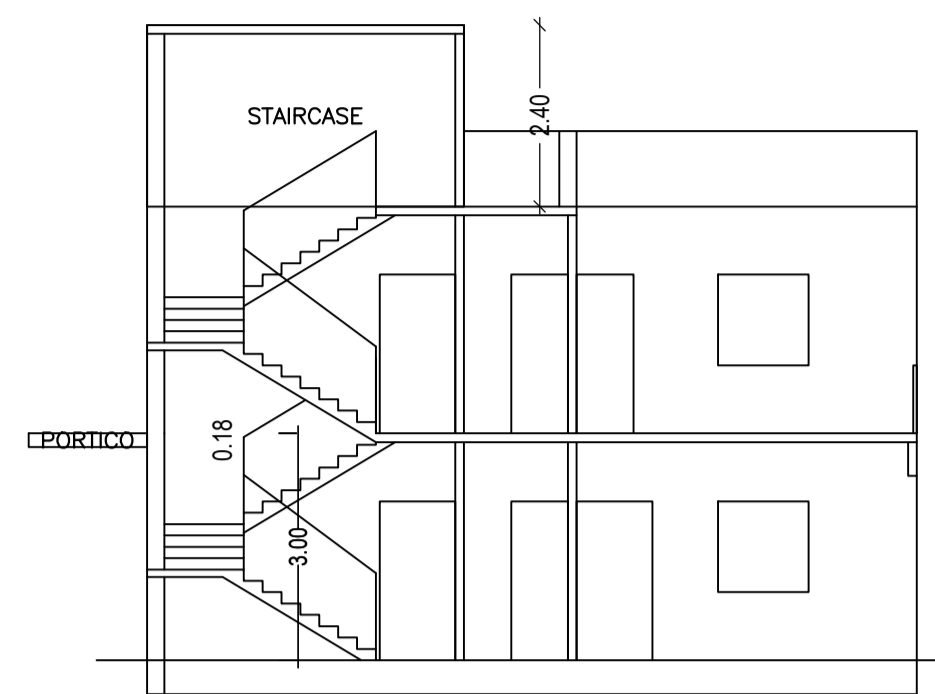

SECTION ON A-A

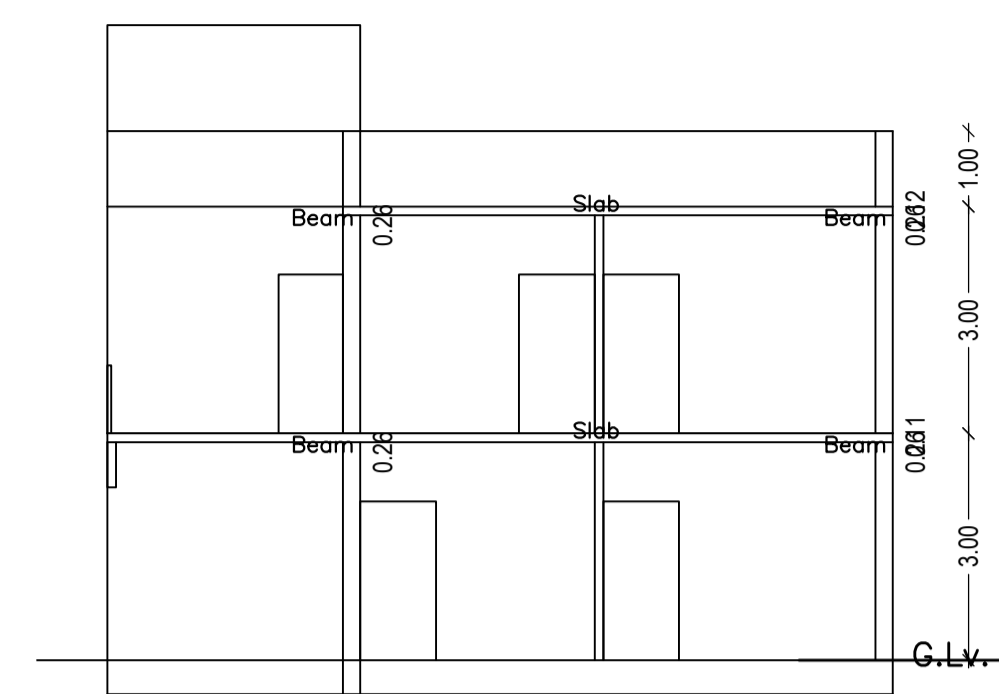

SECTION ON X-X

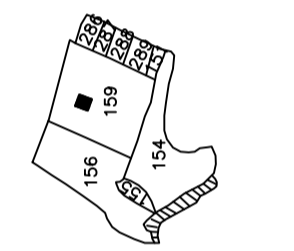

KEY PLAN  
SCALE:- 1"=330'

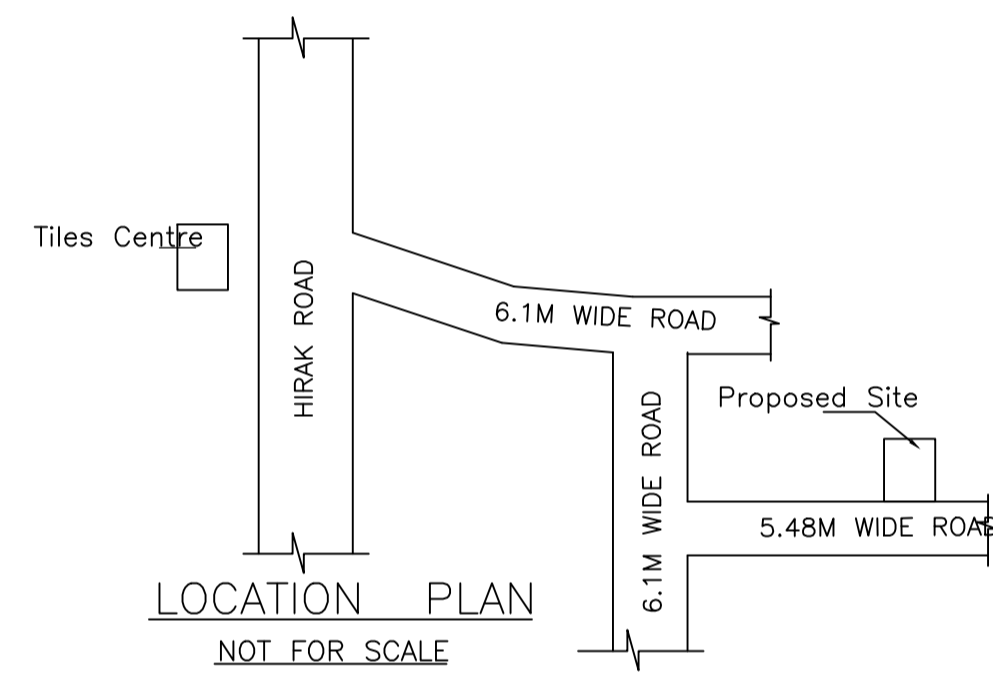

LOCATION PLAN  
NOT FOR SCALE

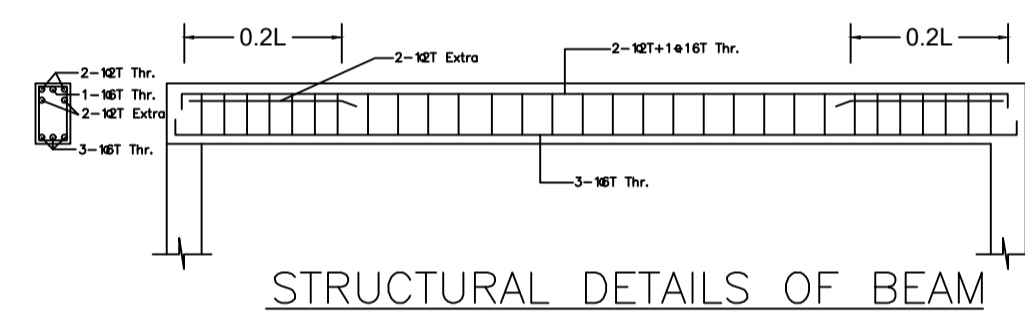

STRUCTURAL DETAILS OF BEAM

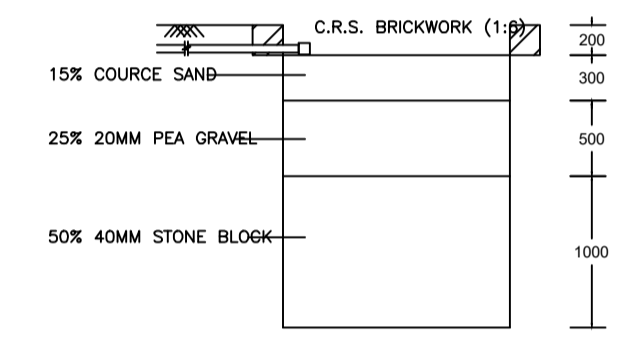

SECTION ON A-A

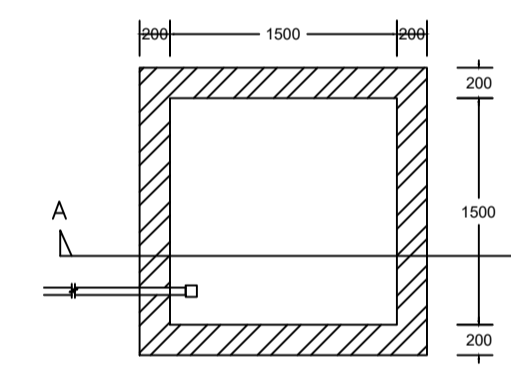

PLAN OF RECHARGE WELL  
(WATER HARVESTING)

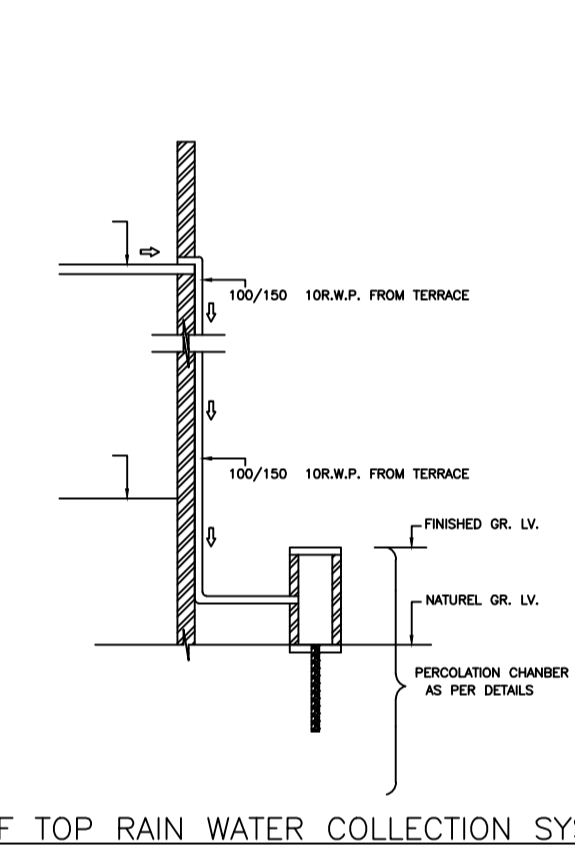

ROOF TOP RAIN WATER COLLECTION SYSTEM

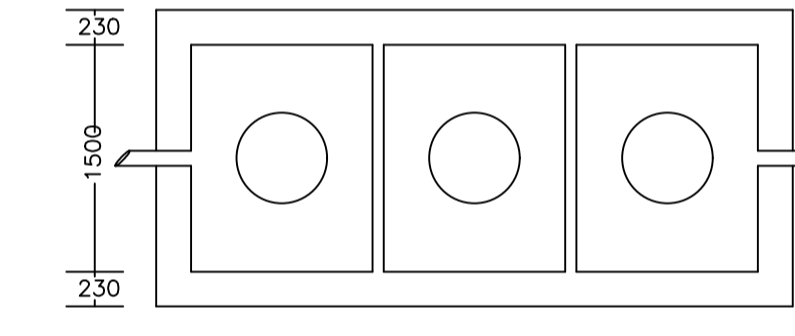
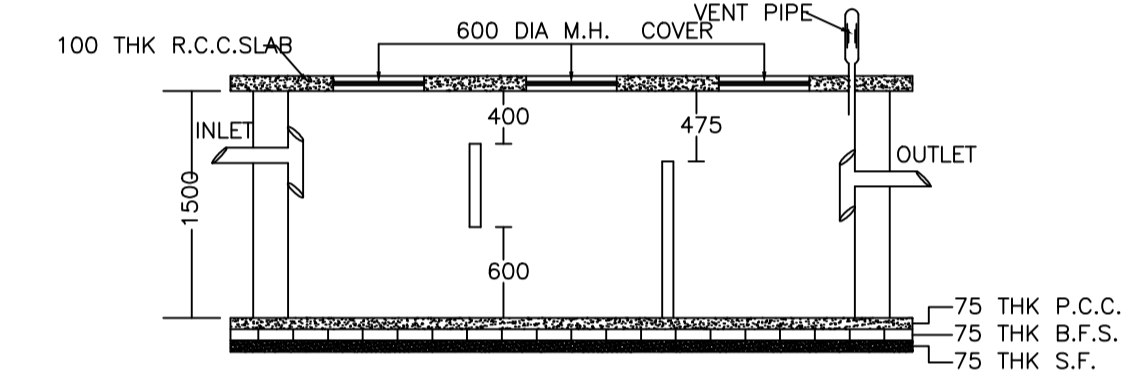

PLAN OF SEPTIC TANK

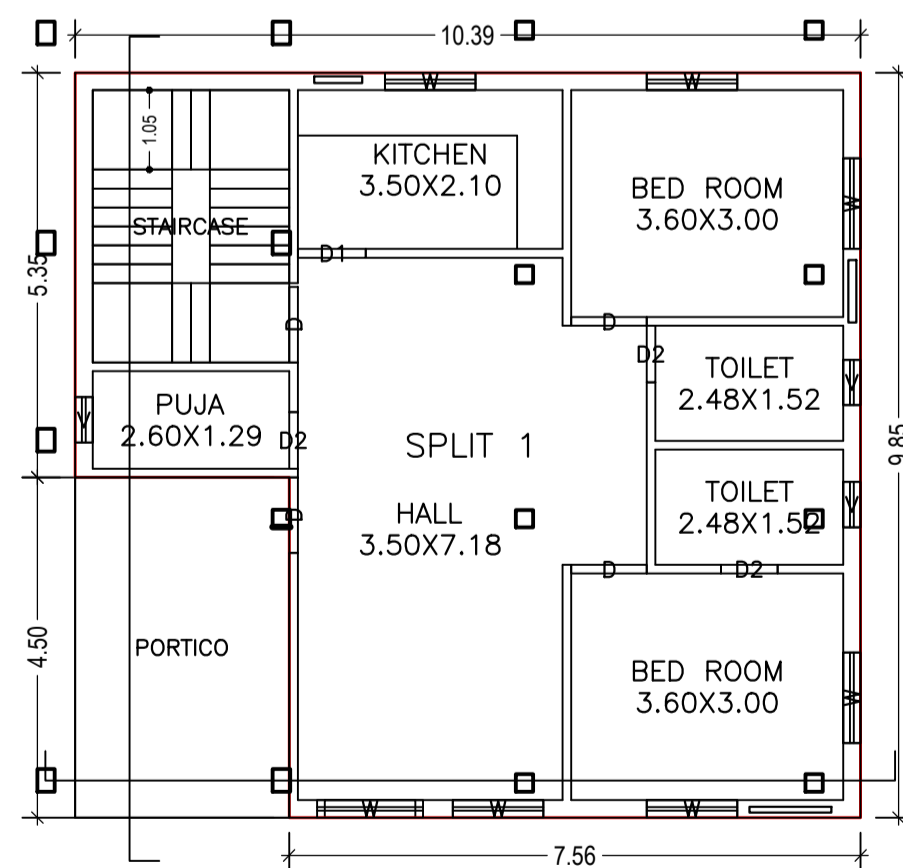

GROUND FLOOR PLAN  
(Proposed)  
(SCALE 1:100)

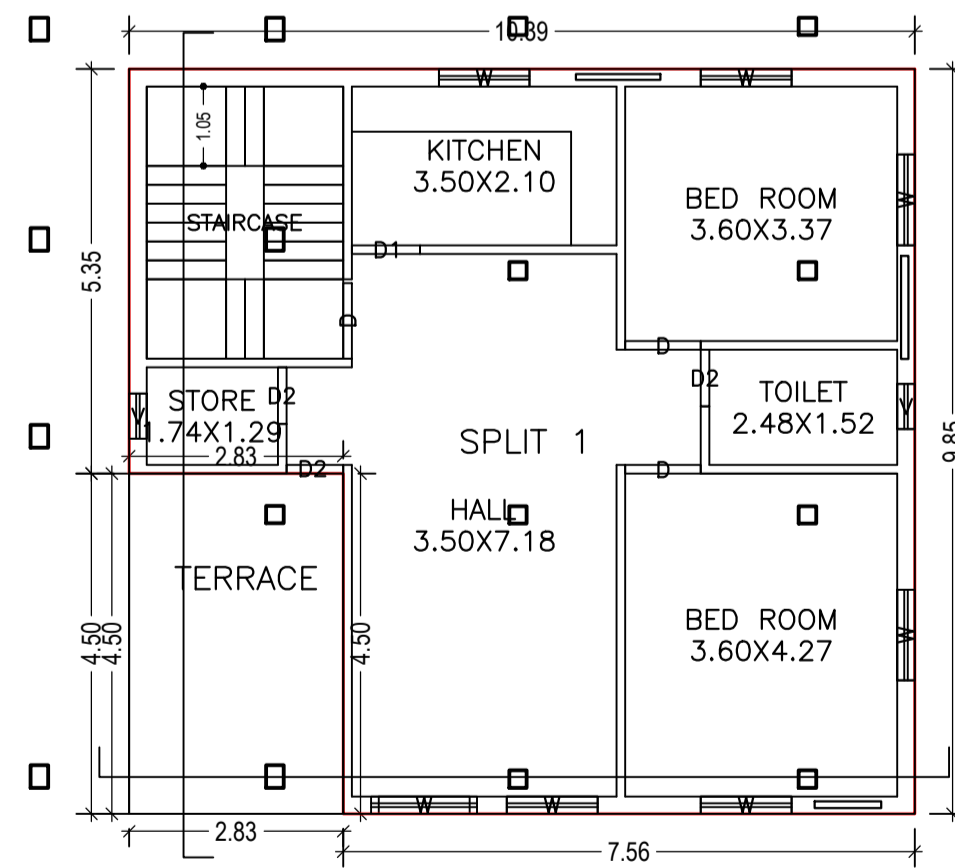

FIRST FLOOR PLAN  
(Proposed)  
(SCALE 1:100)

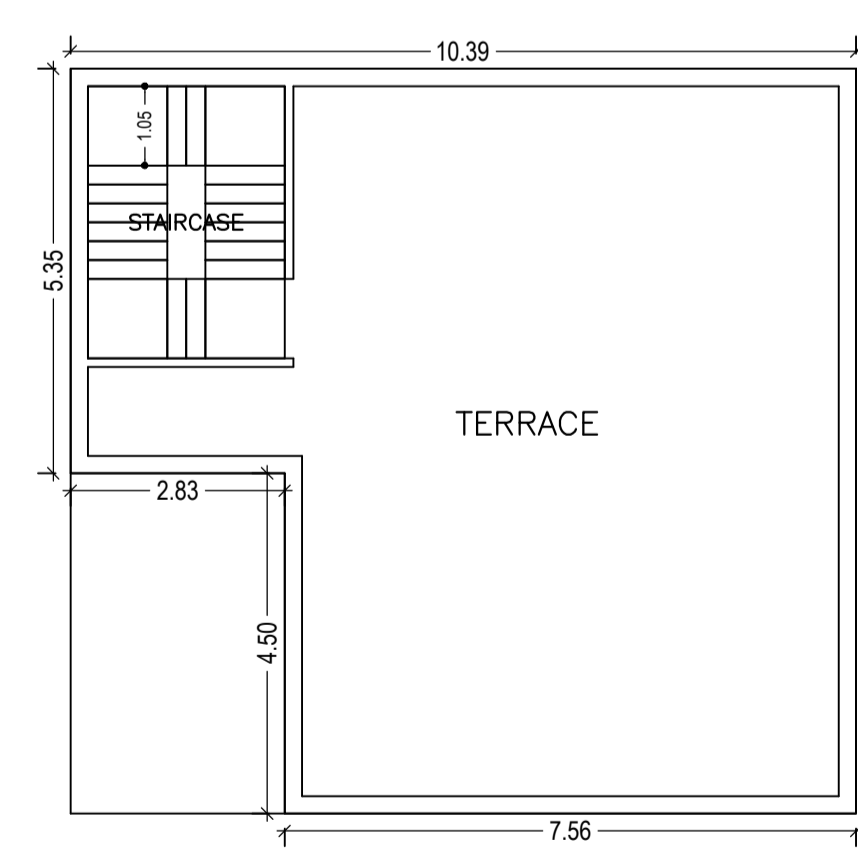

TERRACE FLOOR PLAN  
(SCALE 1:100)

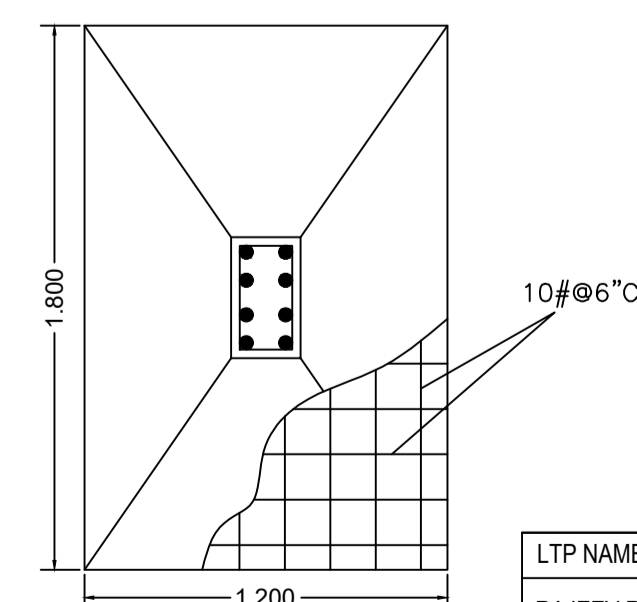
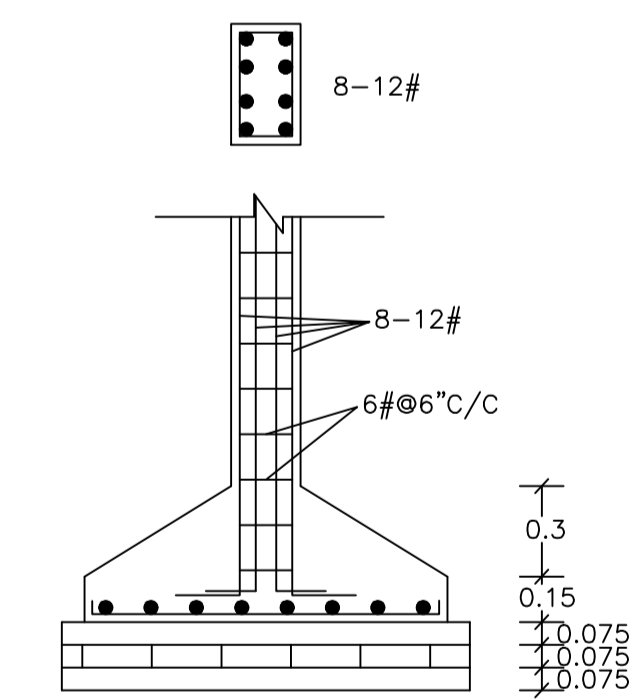

COLUMN DETAILS  
SCALE:- 1:50

LTP NAME AND SIGNATURE	STRUCTURAL ENG'S NAME AND SIGNATURE	BUILDER NAME AND SIGNATURE	DIGITAL SIGNATURE
RAJEEV RANJAN SINGH DMC/ENG/0032/2017			