

SITE PLAN

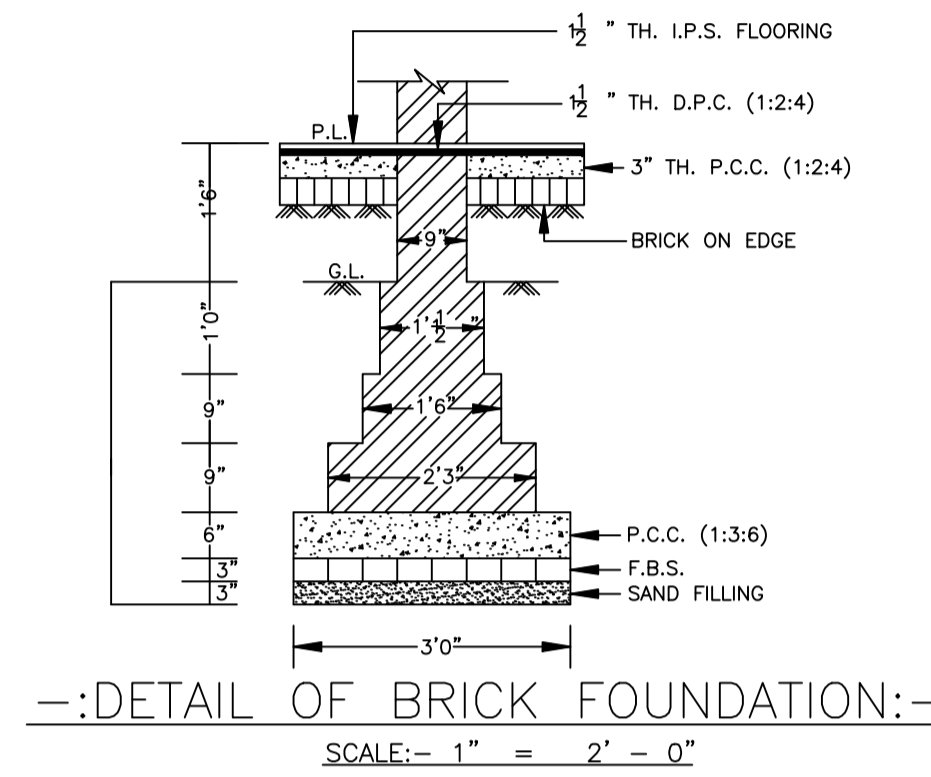

DETAIL OF BRICK FOUNDATION:-

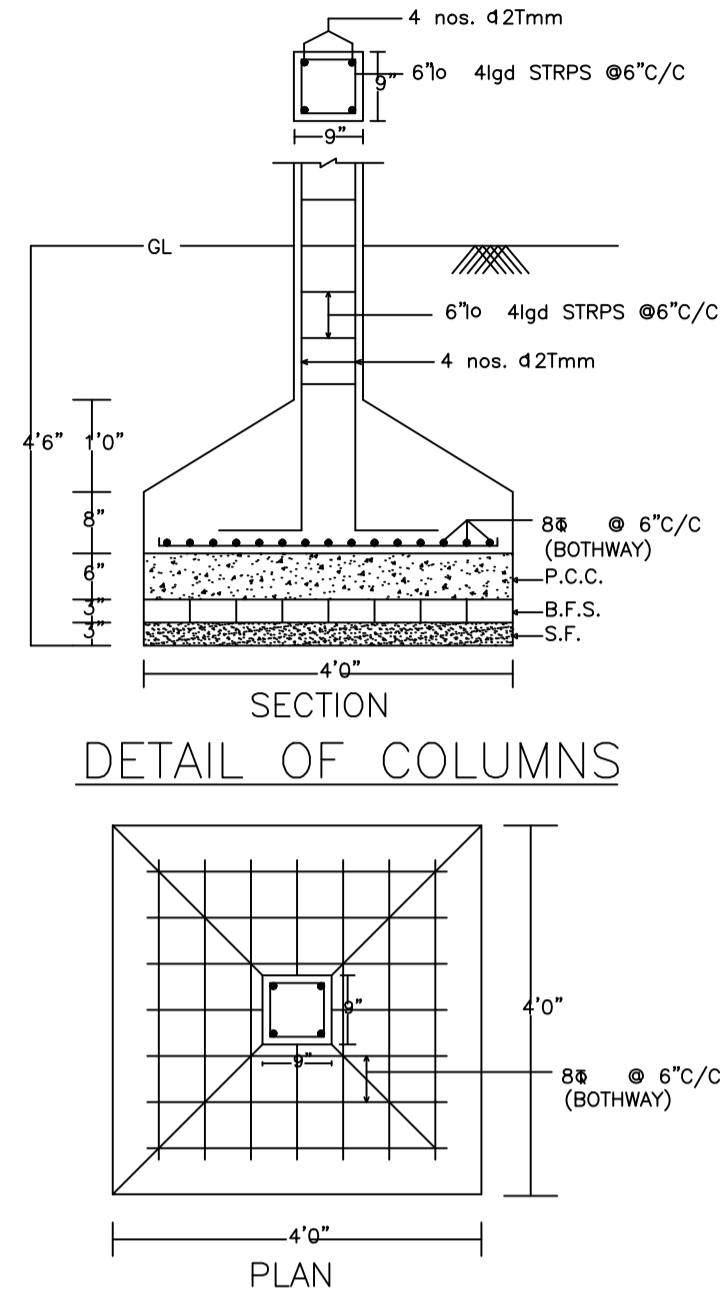
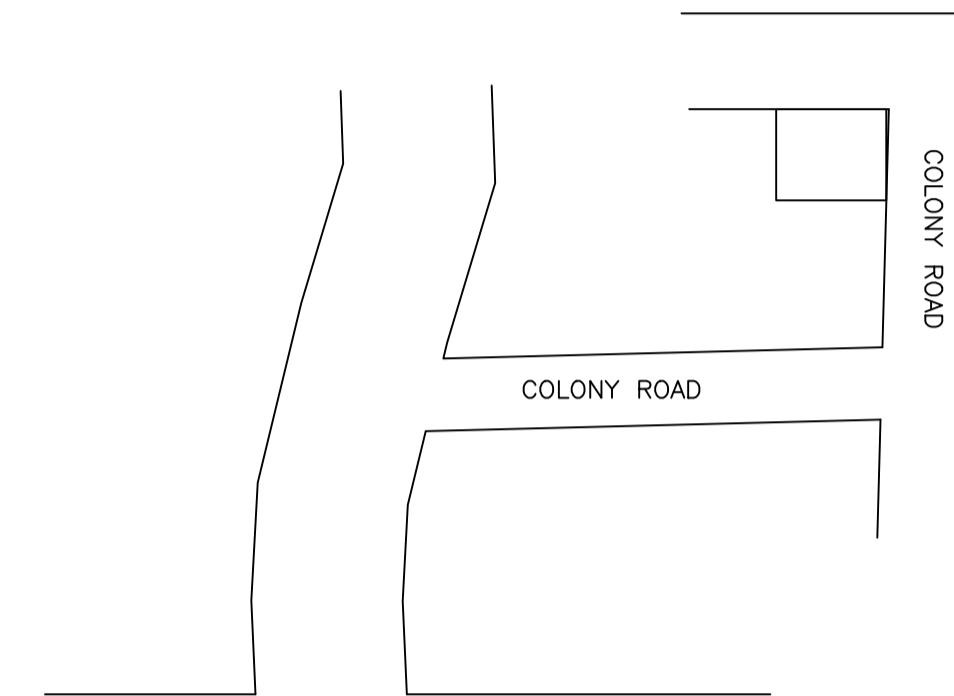

LOCATION PLAN

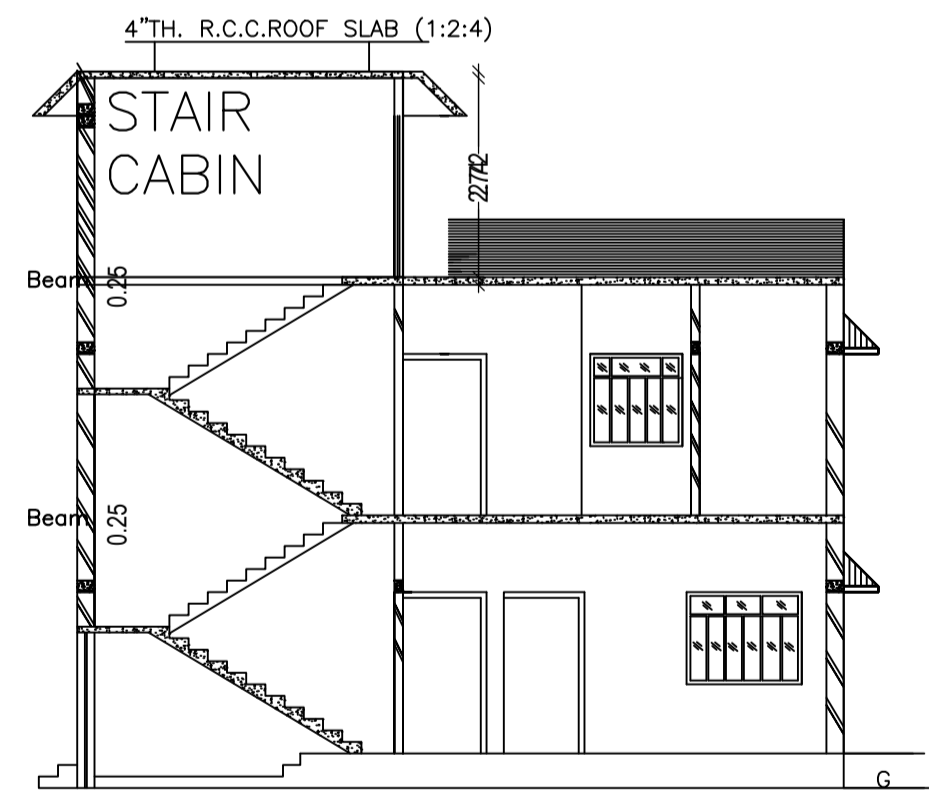

SECTION AT X-X

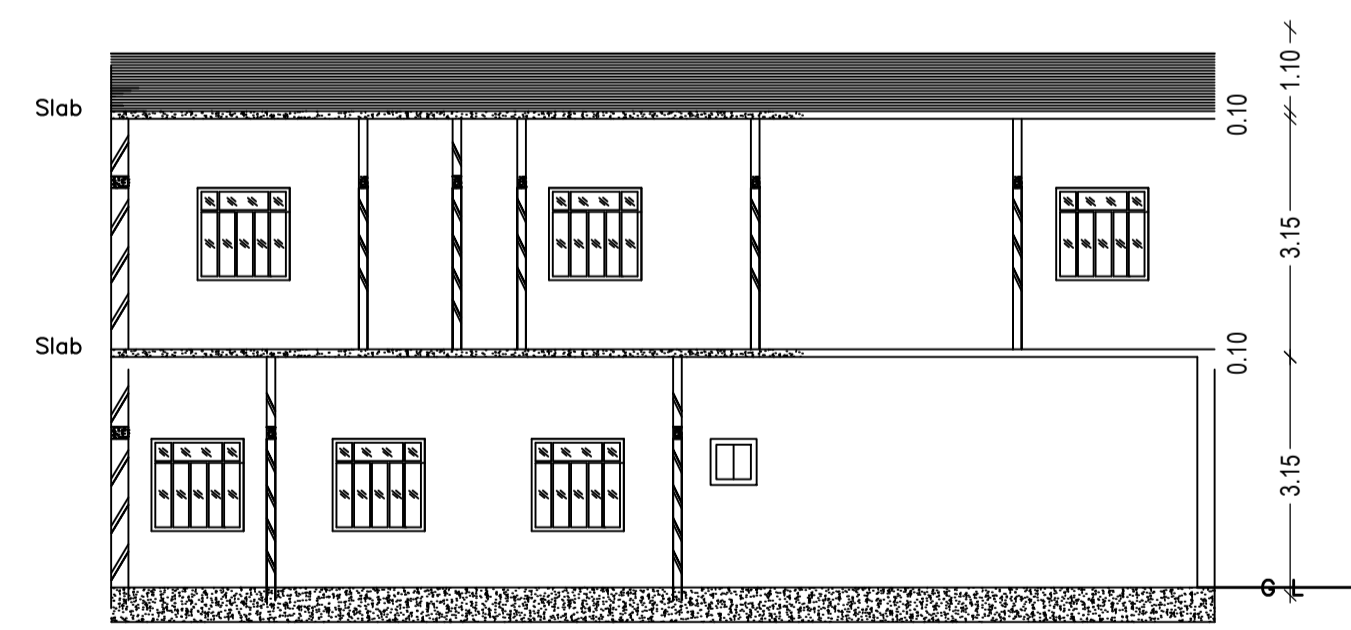

SECTION AT Y-Y

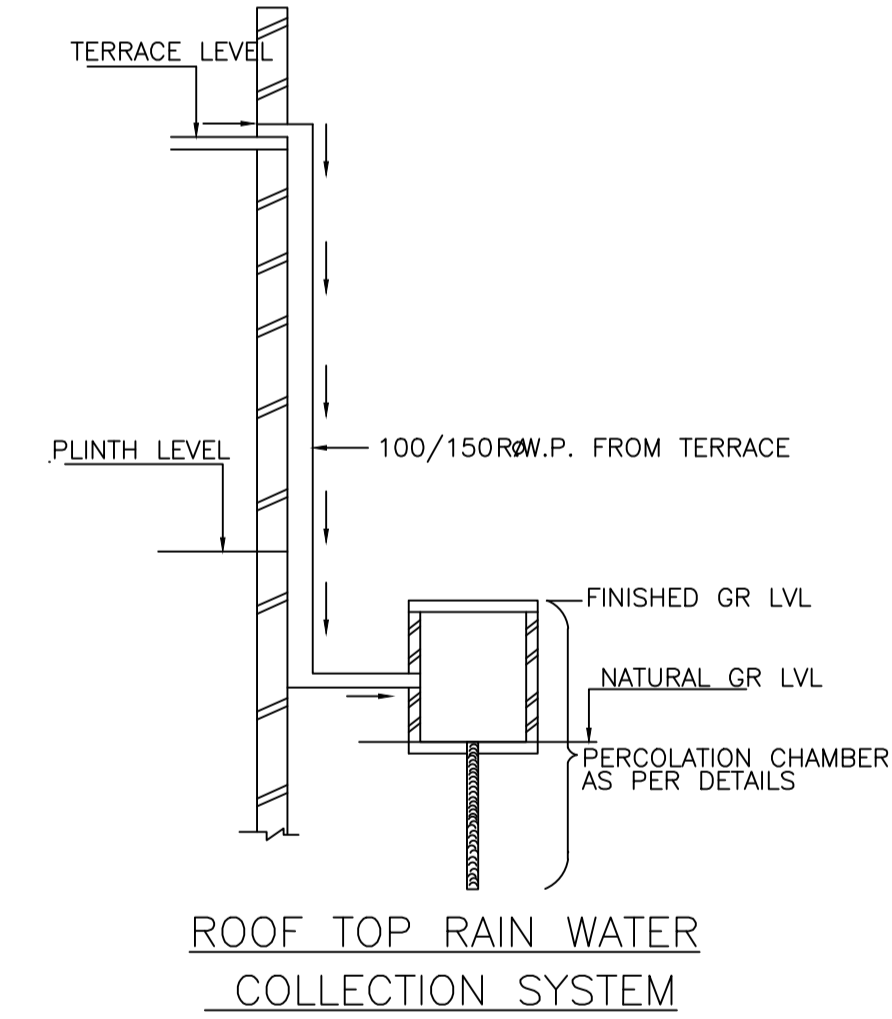
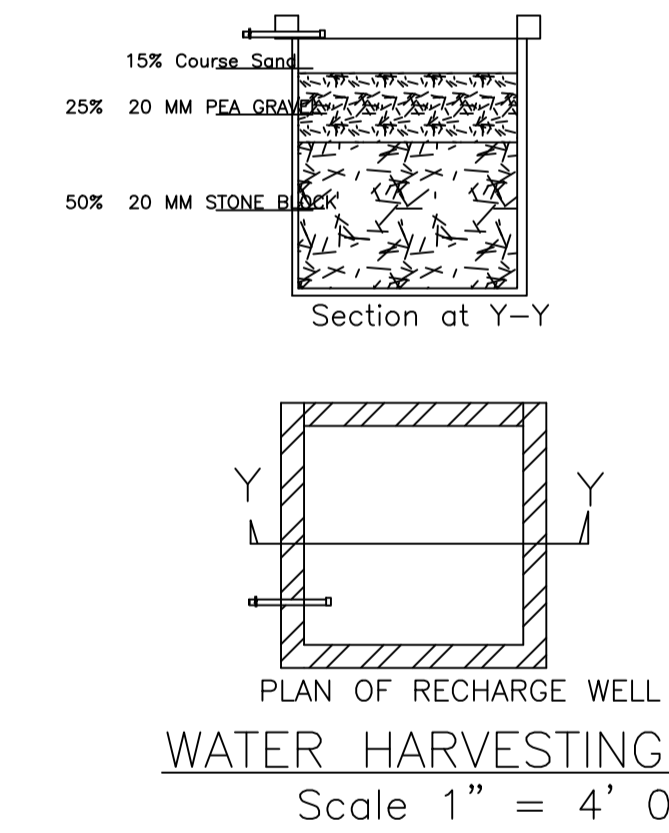

Building USE/SUBUSE Details				Proposal Basic Information	
Building Name	Building Use	Building SubUse	Building Structure	Proposal File No.	DMC/BP/0328/W21/2019
A (SRI SHASHI KANT SINGH)	Residential	Residential Bldg/Apartment	Non-Highrise	Owner Name	SRI SHASHI KANT SINGH
Building :A (SRI SHASHI KANT SINGH)					
Floor Name	Total Built Up Area (Sq.mt.)	Proposed FAR Area (Sq.mt.) Resi.	Total FAR Area (Sq.mt.)	Total Consumed Additional FAR Area (Sq.mt.)	Tnmt (No.)
Ground Floor	147.97	147.97	147.97	147.97	01
First Floor	158.79	158.79	158.79	158.79	00
Terrace Floor	0.00	0.00	0.00	0.00	00
Total	306.76	306.76	306.76	306.76	01
Total Number of Same Buildings	1				
Total	306.76	306.76	306.76	306.76	01

COLOR INDEX	
PLOT BOUNDARY	Black
ABUTTING ROAD	Red
PROPOSED CONSTRUCTION	Green
COMMON PLOT	Yellow
ROAD WIDENING AREA	Orange
EXISTING (To be retained)	Blue
EXISTING (To be demolished)	Light Blue

Floor Name	Building Name		Total	
	Proposed Built Up Area (Sq.mt.)	Proposed FAR Area (Sq.mt.)	Total Proposed Built Up Area (Sq.mt.)	Total FAR Area (Sq.mt.)
Ground Floor	147.97	147.97	147.97	147.97
First Floor	158.79	158.79	158.79	158.79
Terrace Floor	0.00	0.00	0.00	0.00
Total	306.76	306.76	306.76	306.76

UnitBUA Table for Building :A (SRI SHASHI KANT SINGH)

FLOOR	Name	UnitBUA Type	UnitBUA Area	Carpet Area	No. of Rooms	No. of Tenement
GROUND FLOOR PLAN	SPLIT A	FLAT	306.76	306.41	9	1
FIRST FLOOR PLAN	SPLIT A	FLAT	0.00	0.00	11	0
Total	-	-	306.76	306.41	20	1

FAR & Tenement Details (Table 4c-1)

Building	No. of Same Bldg	Total Built Up Area (Sq.mt.)	Proposed FAR Area (Sq.mt.) Resi.	Total FAR Area (Sq.mt.)	Total Consumed Additional FAR Area (Sq.mt.)	Tnmt (No.)
A (SRI SHASHI KANT SINGH)	1	306.76	306.76	306.76	306.76	01
Grand Total :	1	306.76	306.76	306.76	306.76	01

AREA STATEMENT		VERSION NO. : 1.0.42
DHANBAD MUNICIPAL CORPORATION		VERSION DATE: 29/04/2019
PROJECT DETAIL:		
Region: JHARKHAND URBAN LOCAL BODIES		Plot Use: Residential
District: DHANBAD		Plot SubUse: Bungalow/ Dwelling / Non Apartment
Authority: DHANBAD MUNICIPAL CORPORATION		PlotNearbyReligiousStructure: NA
Inward No: DMC/BP/0328/W21/2019		PlotSubPlot No: 2942, NEW-2927
Application Type: General Proposal		North: Plot No. - 2942
Project Type: Building Permission		South: Plot No. - ANITA KUMARI
Nature of Development: New		East: Plot No. - NALA AND SIMA MOUZA SARIDHELA
Location of Development Area: Old Area		West: Road Width - 5.5
AREA DETAILS:		SQ.MT.
AREA OF PLOT (Minimum)		265.94
NET AREA OF PLOT(Gross Plot Area - Deduction from Gross Plot area)		265.94
Deduction for Balance Plot Area(from Gross Plot Area)		
Common Plot		59.00
Total		59.00
BALANCE AREA OF PLOT(Net Plot Area - Recreational/Amenity space)		206.94
PLOT AREA FOR COVERAGE(Net Plot Area)		265.94
Plot Area for FAR (Net Plot Area + Road/Widening Area)		265.94
COVERAGE CHECK		
Permissible Coverage area (60.00 %)		159.56
Proposed Coverage Area (59.71 %)		158.79
Total Prop. Coverage Area (59.71 %)		158.79
Balance coverage area (0.29 %)		0.77
FAR CHECK		
Perm. FAR Area (1.80)		478.69
Total Perm. FAR area		478.69
Residential FAR		306.76
Proposed FAR Area		306.76
Total Proposed FAR Area		306.76
Consumed FAR (Factor)		1.15
Balance FAR Area		171.93
BUILT UP AREA CHECK		
Total Proposed BuiltUp Area		306.76
ARCHITECT (Regd)		RAJEEV RANJAN SINGH
ENGINEER (Regd)		
SUPERVISOR (Regd)		
OWNER (Regd)		SRI SHASHI KANT SINGH
DEVELOPMENT AUTHORITY		LOCAL BODY

LTP NAME AND SIGNATURE	STRUCTURAL ENG'S NAME AND SIGNATURE	BUILDER NAME AND SIGNATURE	DIGITAL SIGNATURE
RAJEEV RANJAN SINGH DMC/ENG/0032/2017			

Proposal Basic Information

Proposal File No.	DMC/BP/0328/W21/2019
Owner Name	SRI SHASHI KANT SINGH
Khata No	89, NEW-119
Plot No	2942, NEW-2927
Village Name	Bhelaland
Use	Residential
SubUse	Bungalow/ Dwelling / Non Apartment

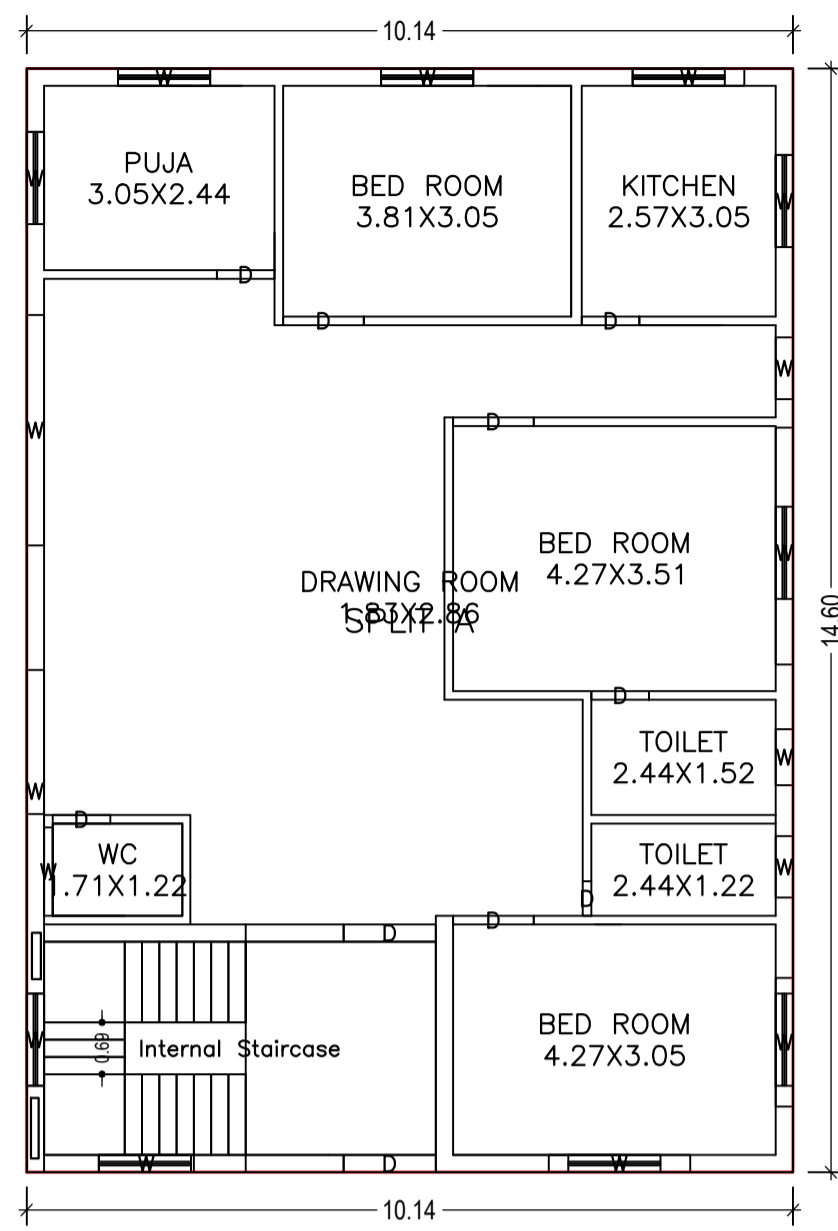

GROUND FLOOR PLAN (Proposed) (SCALE 1:100)

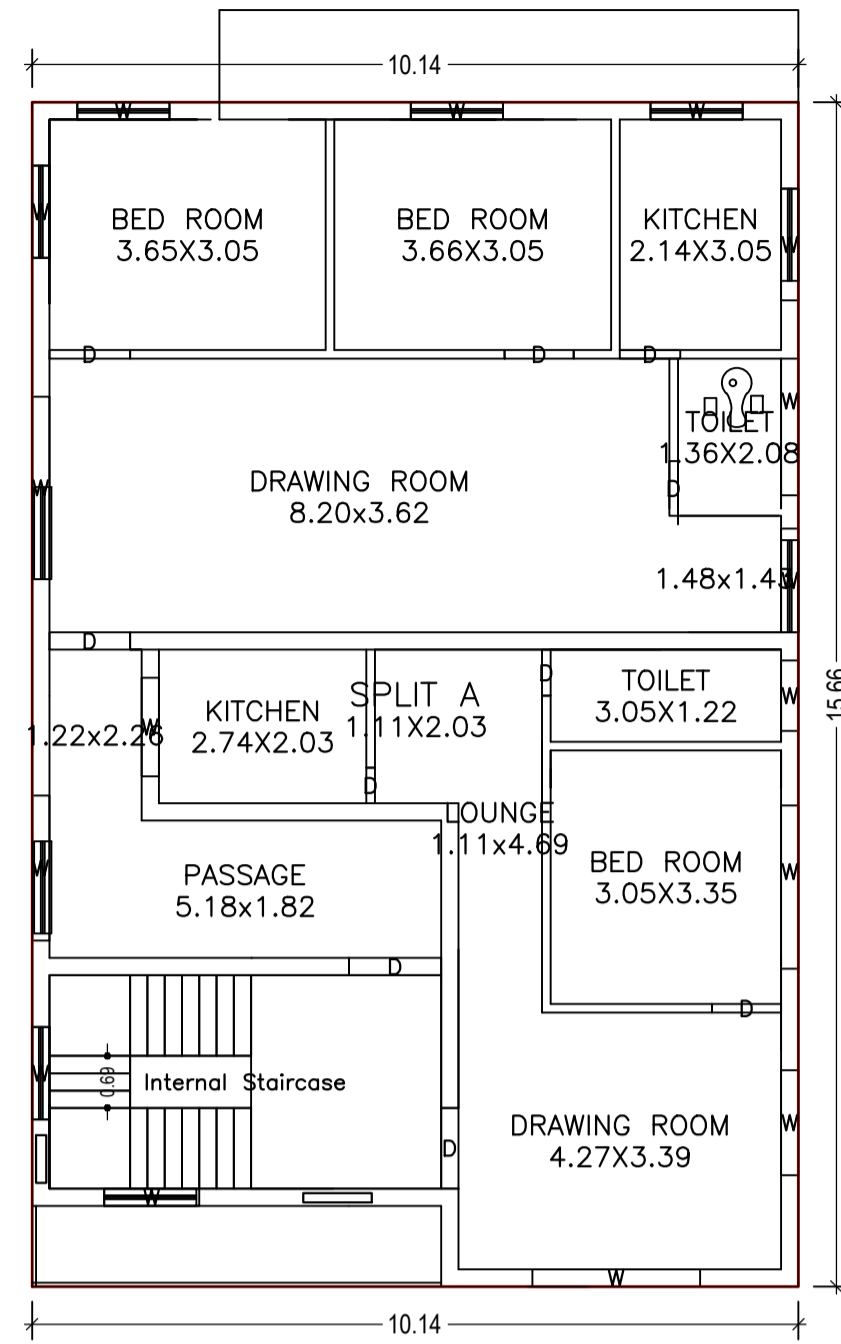

FIRST FLOOR PLAN (Proposed) (SCALE 1:100)

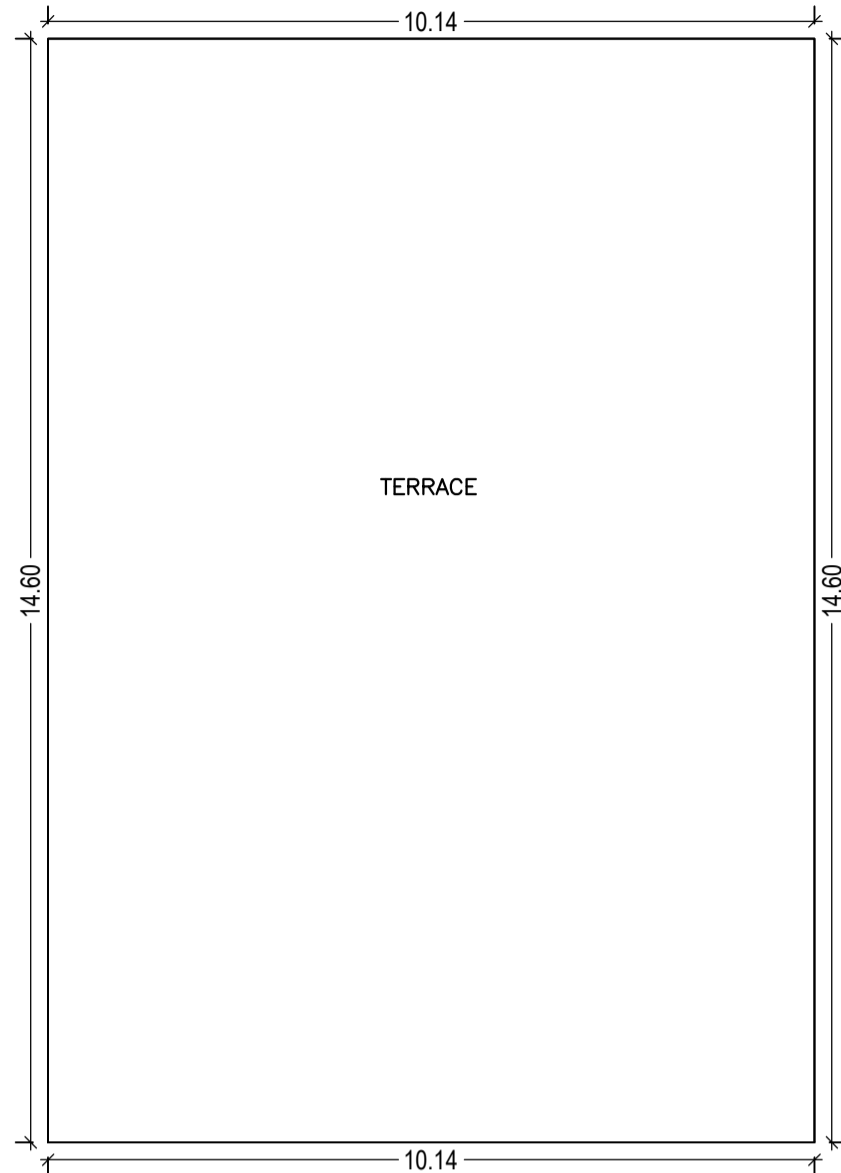

TERRACE FLOOR PLAN (SCALE 1:100)

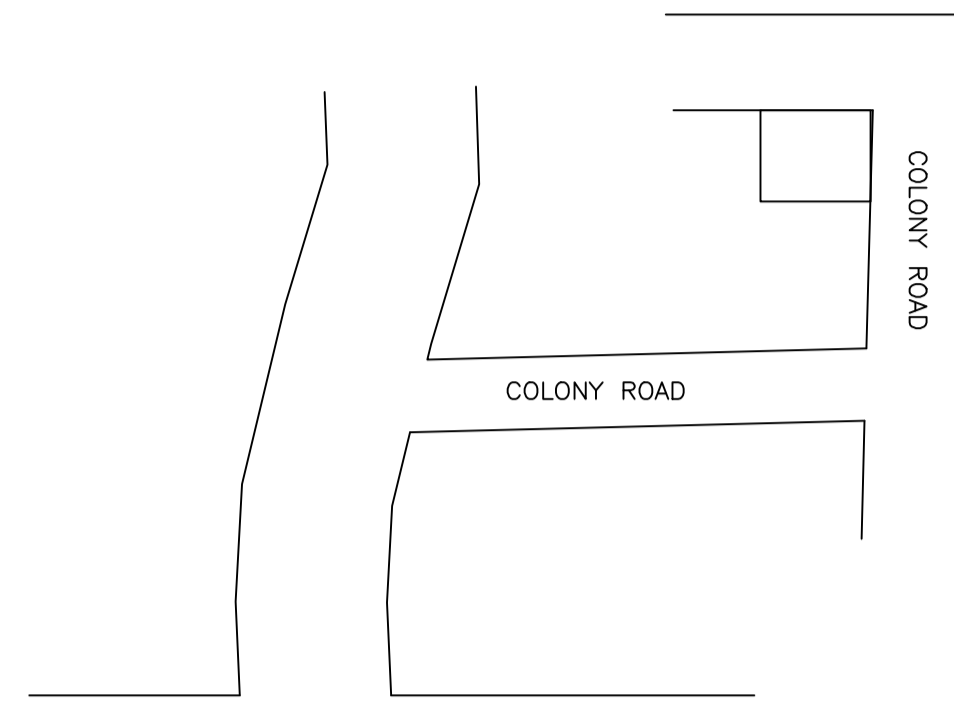

LOCATION PLAN

Building USE/SUBUSE Details

Building Name	Building Use	Building SubUse	Building Structure
A (SRI SHASHI KANT SINGH)	Residential	Residential Bldg/Apartment	Non-Highrise

Building :A (SRI SHASHI KANT SINGH)

Floor Name	Total Built Up Area (Sq.mt.)	Proposed FAR Area (Sq.mt.)	Total FAR Area (Sq.mt.)	Total Consumed Additional FAR Area (Sq.mt.)	Tnmt (No.)
Ground Floor	147.97	147.97	147.97	147.97	01
First Floor	158.79	158.79	158.79	158.79	00
Terrace Floor	0.00	0.00	0.00	0.00	00
Total :	306.76	306.76	306.76	306.76	01
Total Number of Same Buildings	1				
Total :	306.76	306.76	306.76	306.76	01

SCHEDULE OF DOOR:

BUILDING NAME	NAME	LENGTH	HEIGHT	NOS
A (SRI SHASHI KANT SINGH)	D	0.46	2.10	01
A (SRI SHASHI KANT SINGH)	D	0.47	2.10	01
A (SRI SHASHI KANT SINGH)	D	0.61	2.10	01
A (SRI SHASHI KANT SINGH)	D	0.72	2.10	01
A (SRI SHASHI KANT SINGH)	D	0.76	2.10	04
A (SRI SHASHI KANT SINGH)	D	0.80	2.10	01
A (SRI SHASHI KANT SINGH)	D	0.91	2.10	02
A (SRI SHASHI KANT SINGH)	D	1.07	2.10	06
A (SRI SHASHI KANT SINGH)	D	1.22	2.10	01

SCHEDULE OF WINDOW/VENTILATION:

BUILDING NAME	NAME	LENGTH	HEIGHT	NOS
A (SRI SHASHI KANT SINGH)	W	0.74	1.20	01
A (SRI SHASHI KANT SINGH)	W	0.81	1.20	02
A (SRI SHASHI KANT SINGH)	W	0.93	1.20	01
A (SRI SHASHI KANT SINGH)	W	1.17	1.20	01
A (SRI SHASHI KANT SINGH)	W	1.22	1.20	10
A (SRI SHASHI KANT SINGH)	W	1.26	1.20	02
A (SRI SHASHI KANT SINGH)	W	1.30	1.20	01
A (SRI SHASHI KANT SINGH)	W	1.37	1.20	01
A (SRI SHASHI KANT SINGH)	W	1.39	1.20	01
A (SRI SHASHI KANT SINGH)	W	1.48	1.20	02
A (SRI SHASHI KANT SINGH)	W	1.70	1.20	01
A (SRI SHASHI KANT SINGH)	W	1.81	1.20	01
A (SRI SHASHI KANT SINGH)	W	1.87	1.20	01
A (SRI SHASHI KANT SINGH)	W	1.91	1.20	01
A (SRI SHASHI KANT SINGH)	W	1.92	1.20	01
A (SRI SHASHI KANT SINGH)	W	2.16	1.20	01
A (SRI SHASHI KANT SINGH)	W	2.22	1.20	01
A (SRI SHASHI KANT SINGH)	W	2.41	1.20	01
A (SRI SHASHI KANT SINGH)	W	3.05	1.20	01
A (SRI SHASHI KANT SINGH)	W	3.13	1.20	01

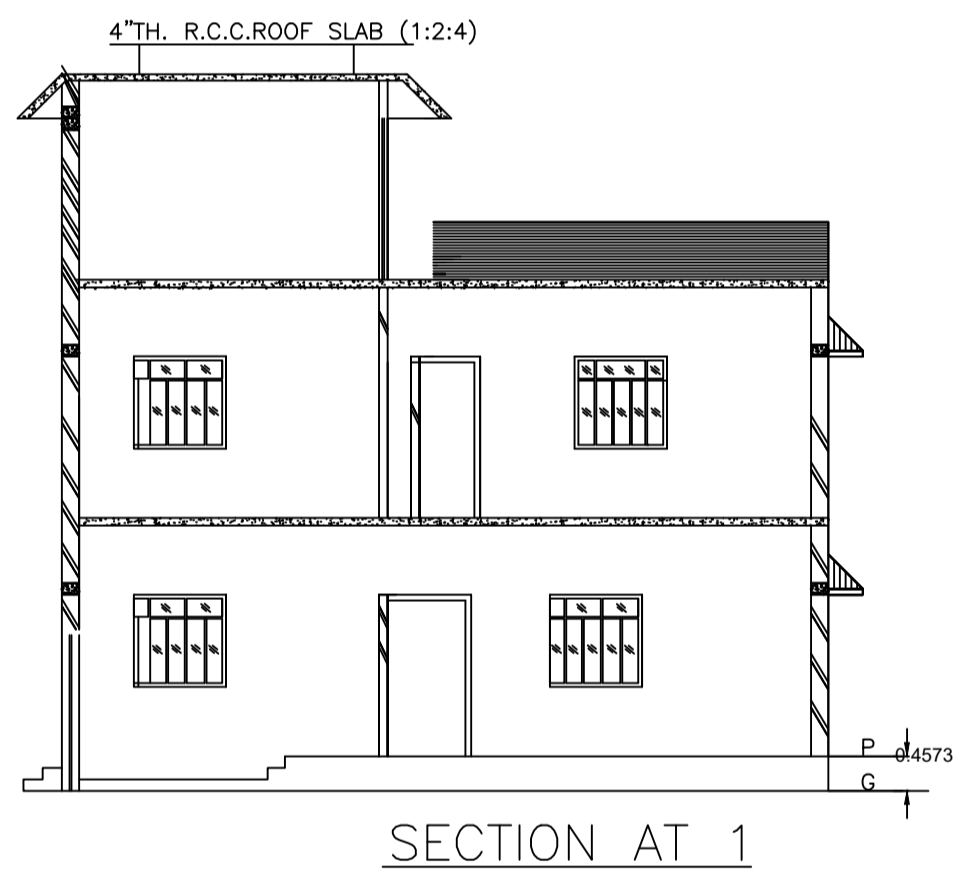

SECTION AT 1

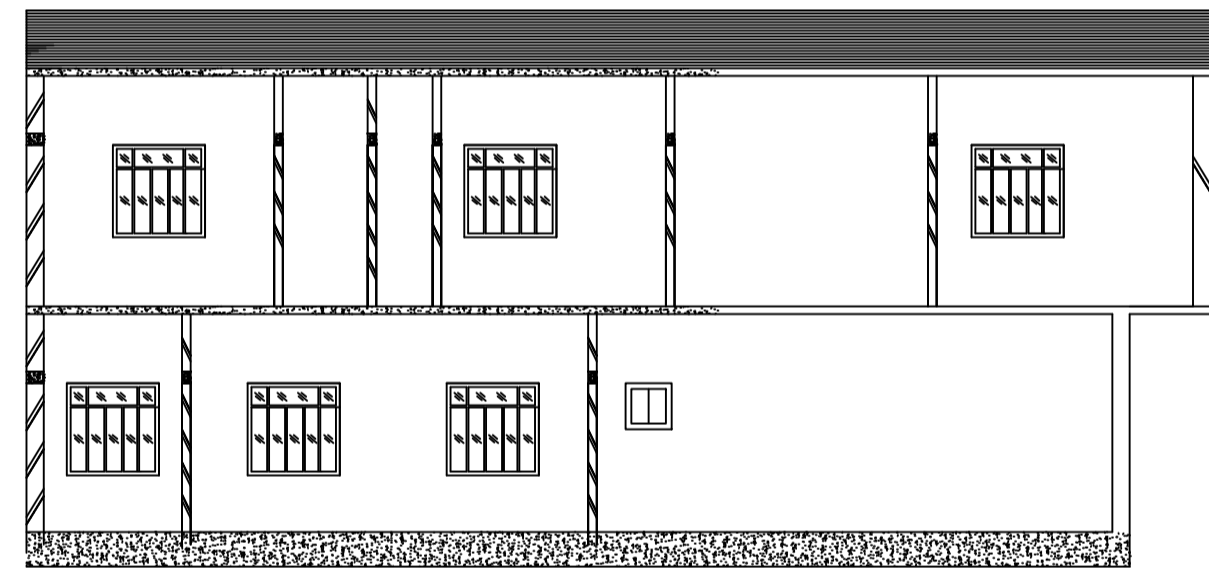

SECTION AT Y-Y

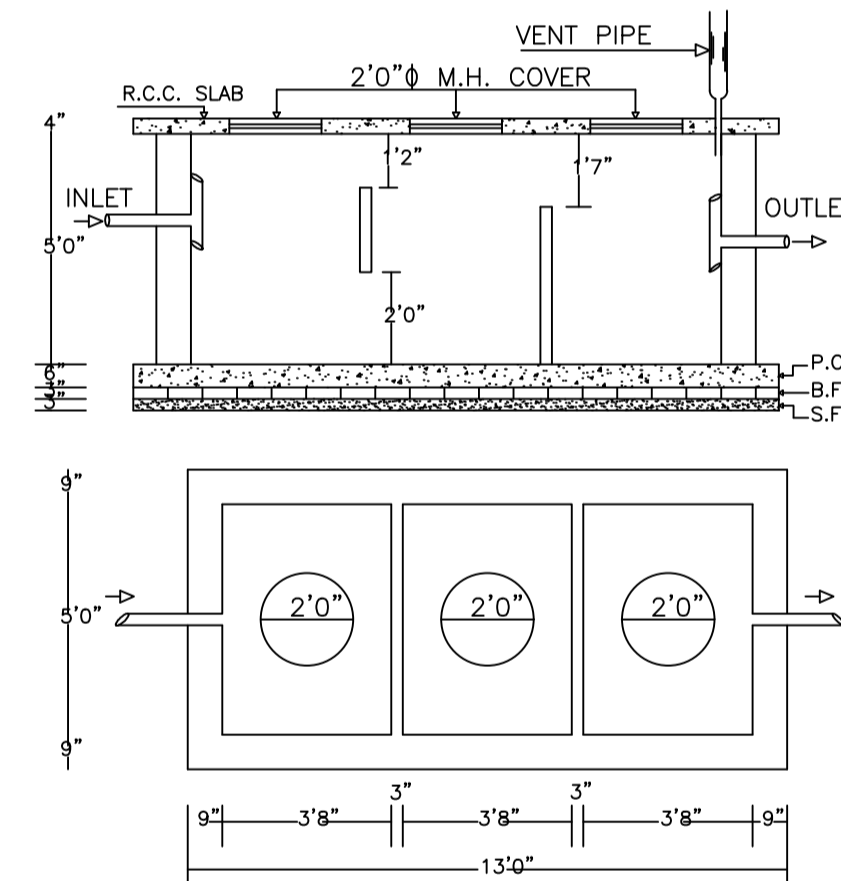

PLAN OF SEPTIC TANK
SCALE:- 1" = 4' - 0"

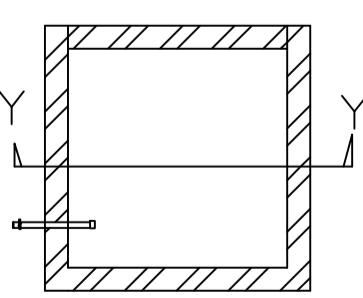
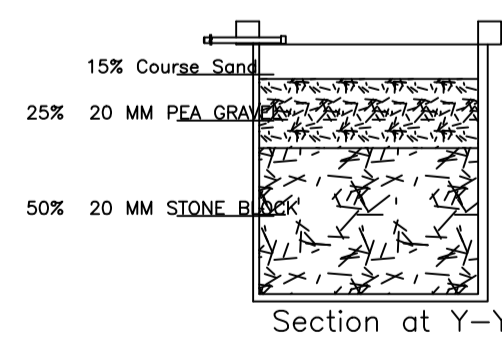

PLAN OF RECHARGE WELL
WATER HARVESTING
Scale 1" = 4' 0"

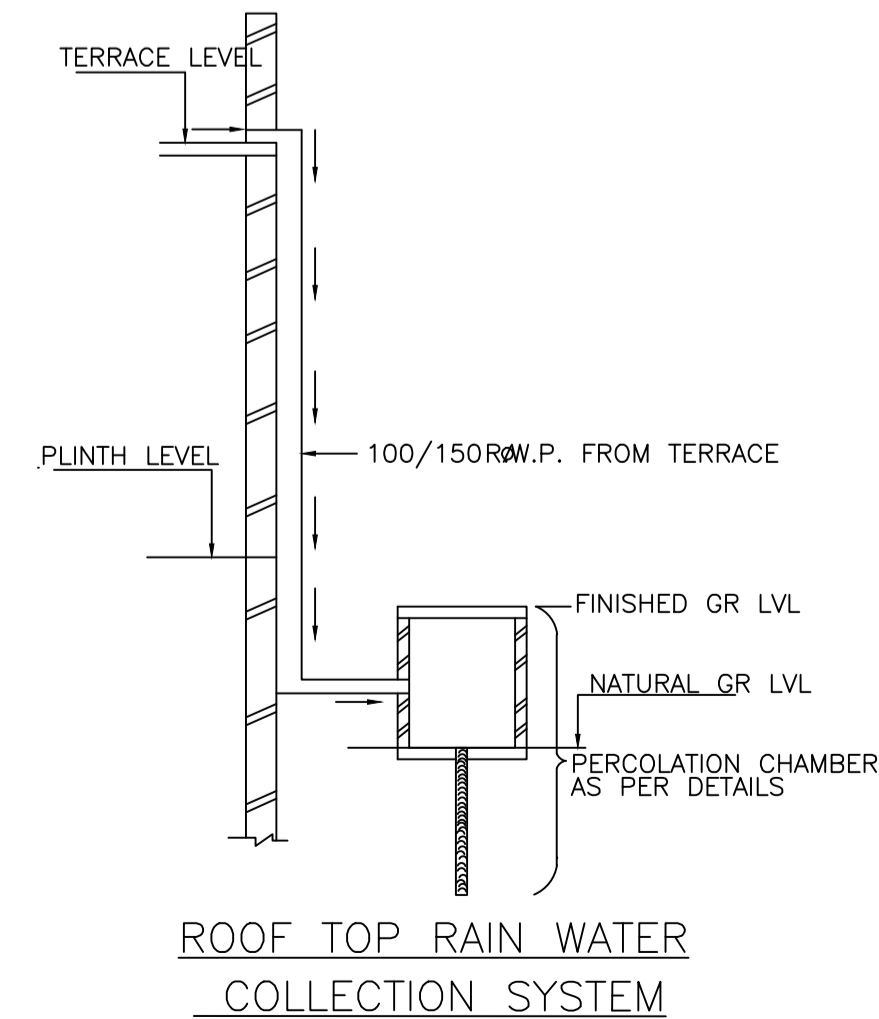

ROOF TOP RAIN WATER COLLECTION SYSTEM

LTP NAME AND SIGNATURE	STRUCTURAL ENG'S NAME AND SIGNATURE	BUILDER NAME AND SIGNATURE	DIGITAL SIGNATURE
RAJEEV RANJAN SINGH DMC/ENG/0032/2017			