

SITE PLAN

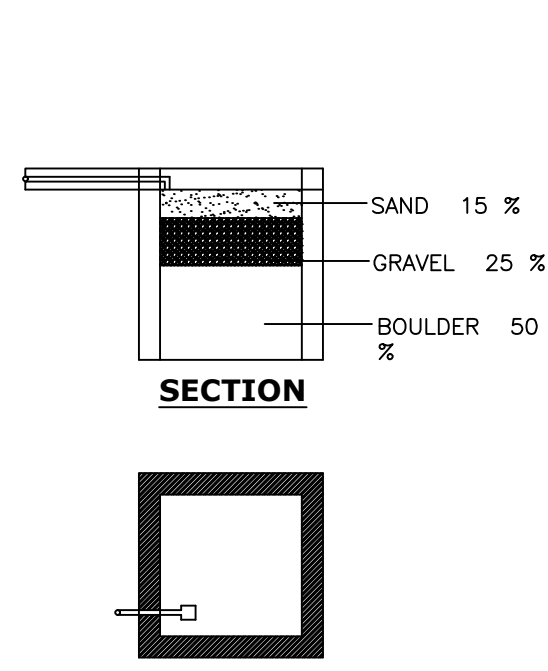

SECTION

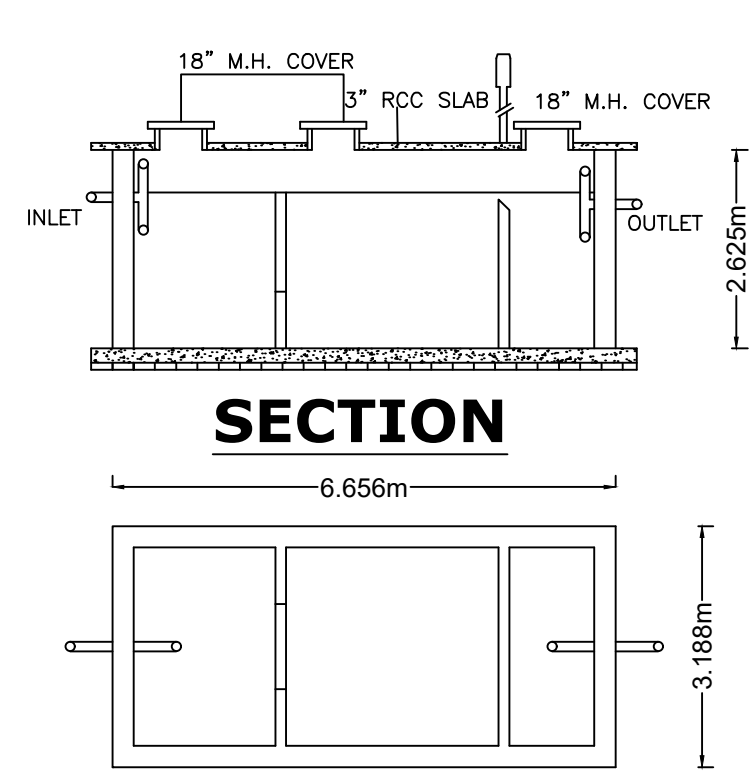

SECTION

PLAN OF SEPTIC TANK

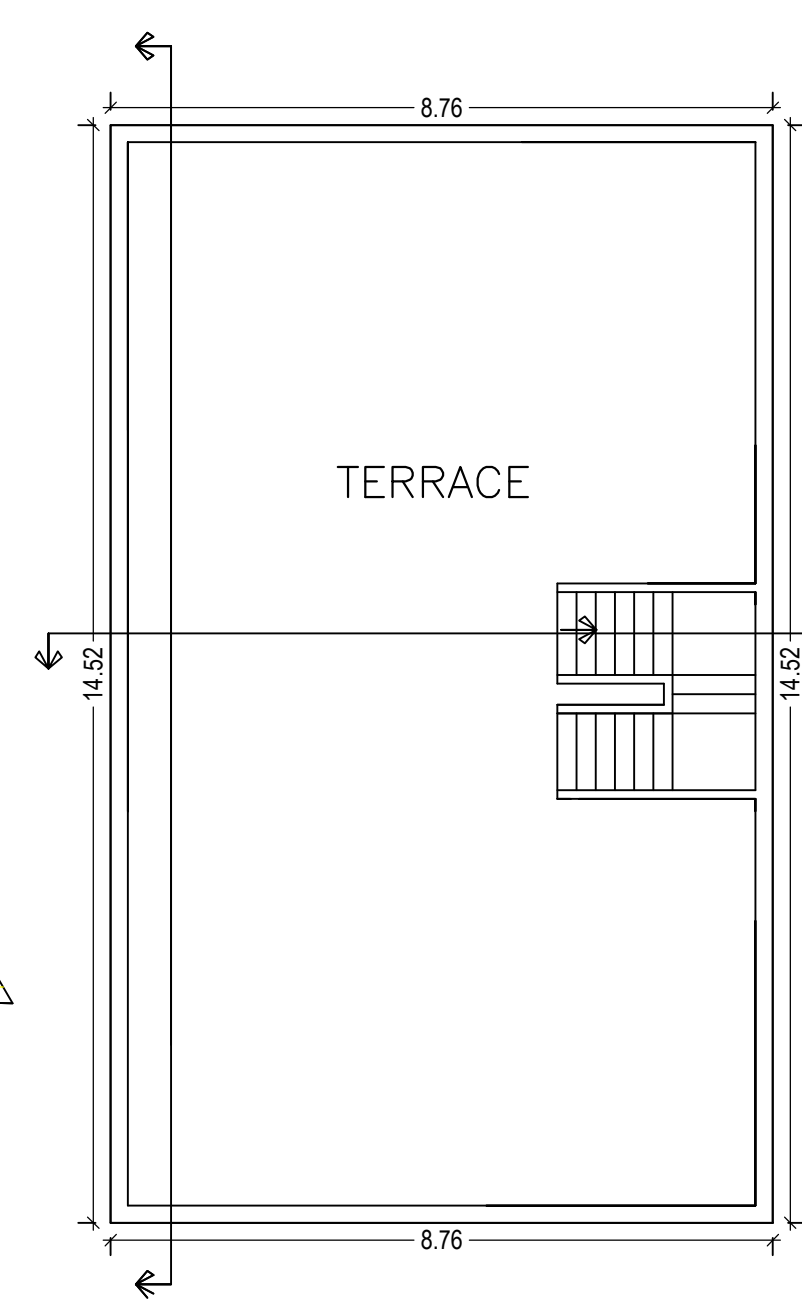

TERRACE FLOOR PLAN (SCALE 1:100)

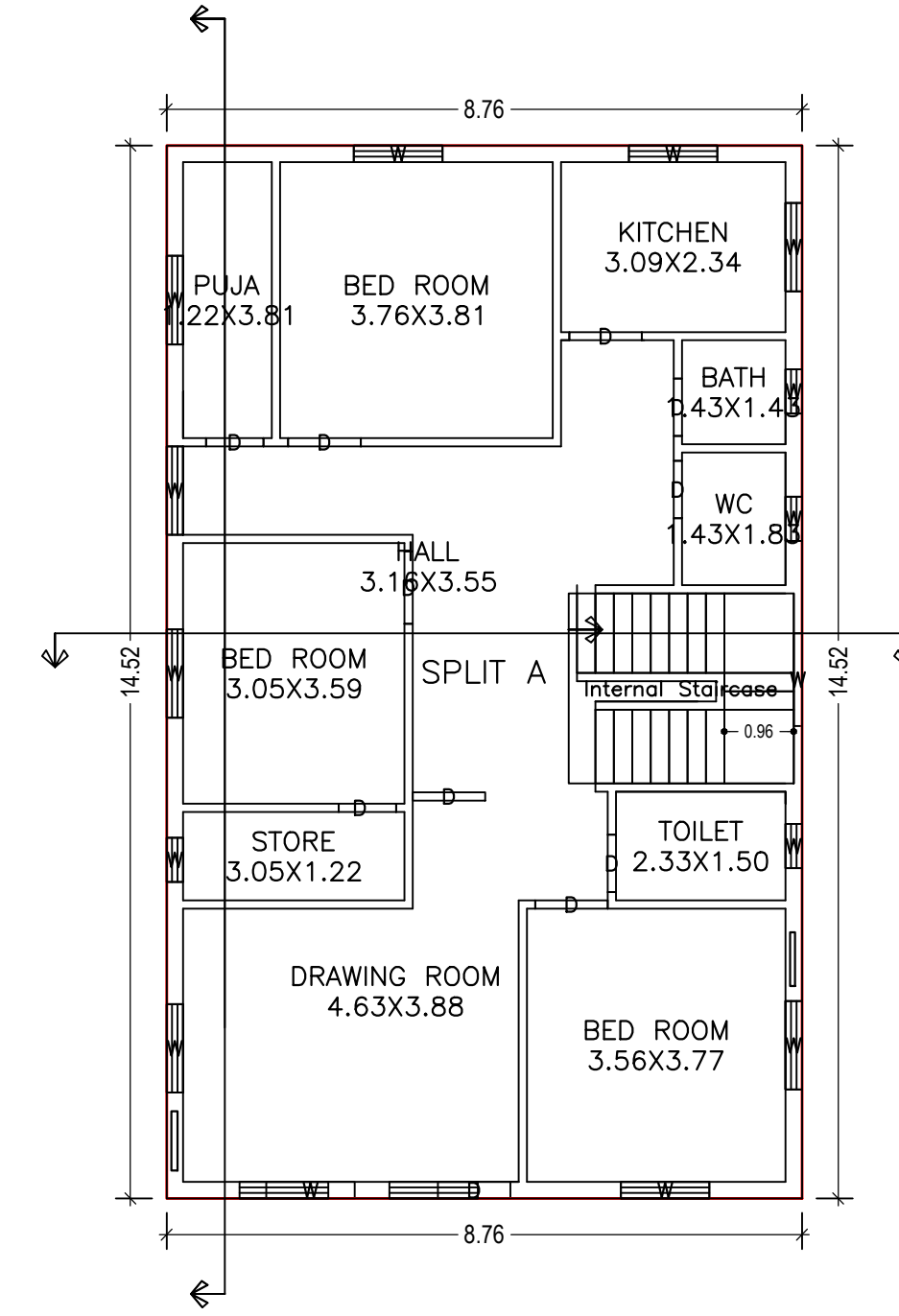

TYPICAL - FIRST FLOOR PLAN (Proposed) (SCALE 1:100)

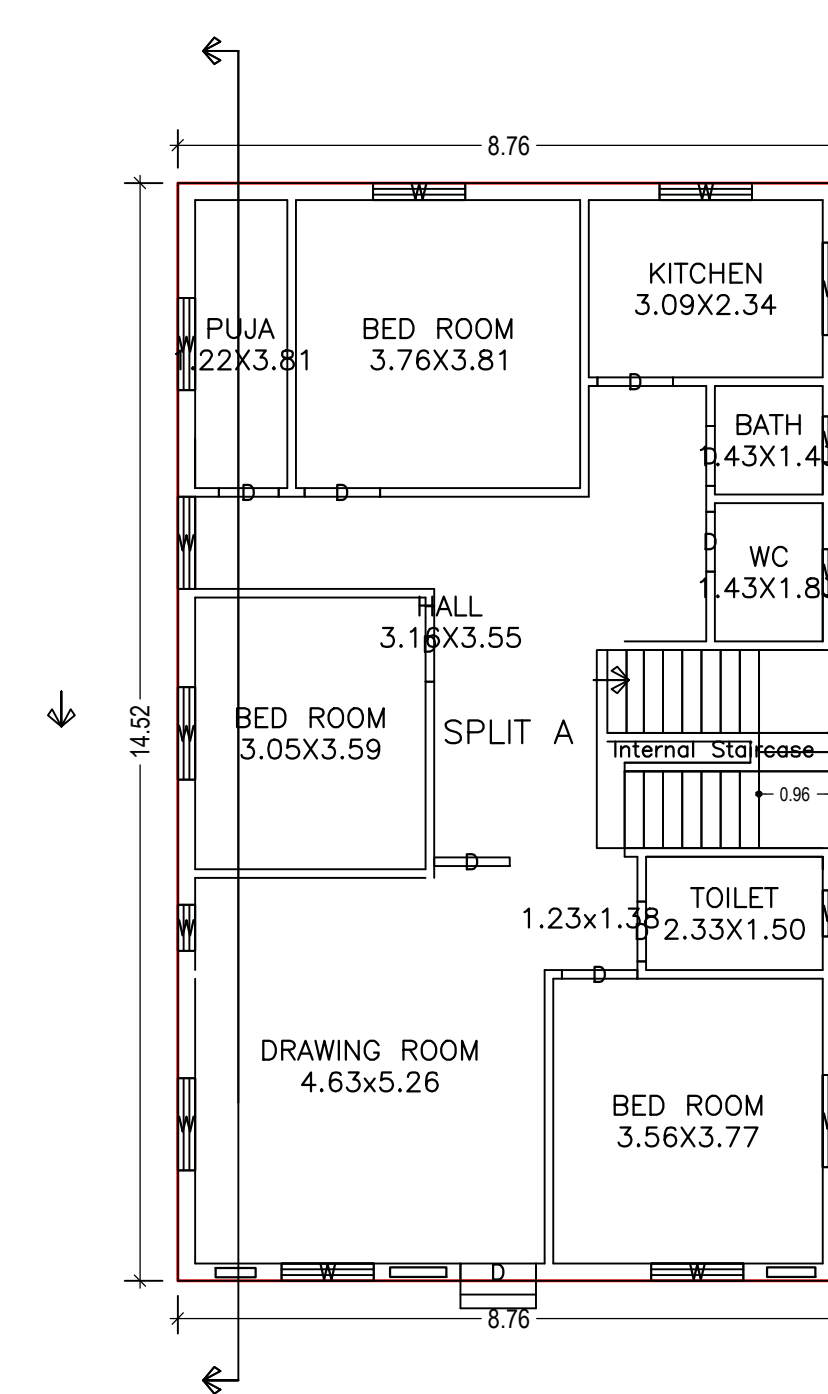

GROUND FLOOR PLAN (Proposed) (SCALE 1:100)

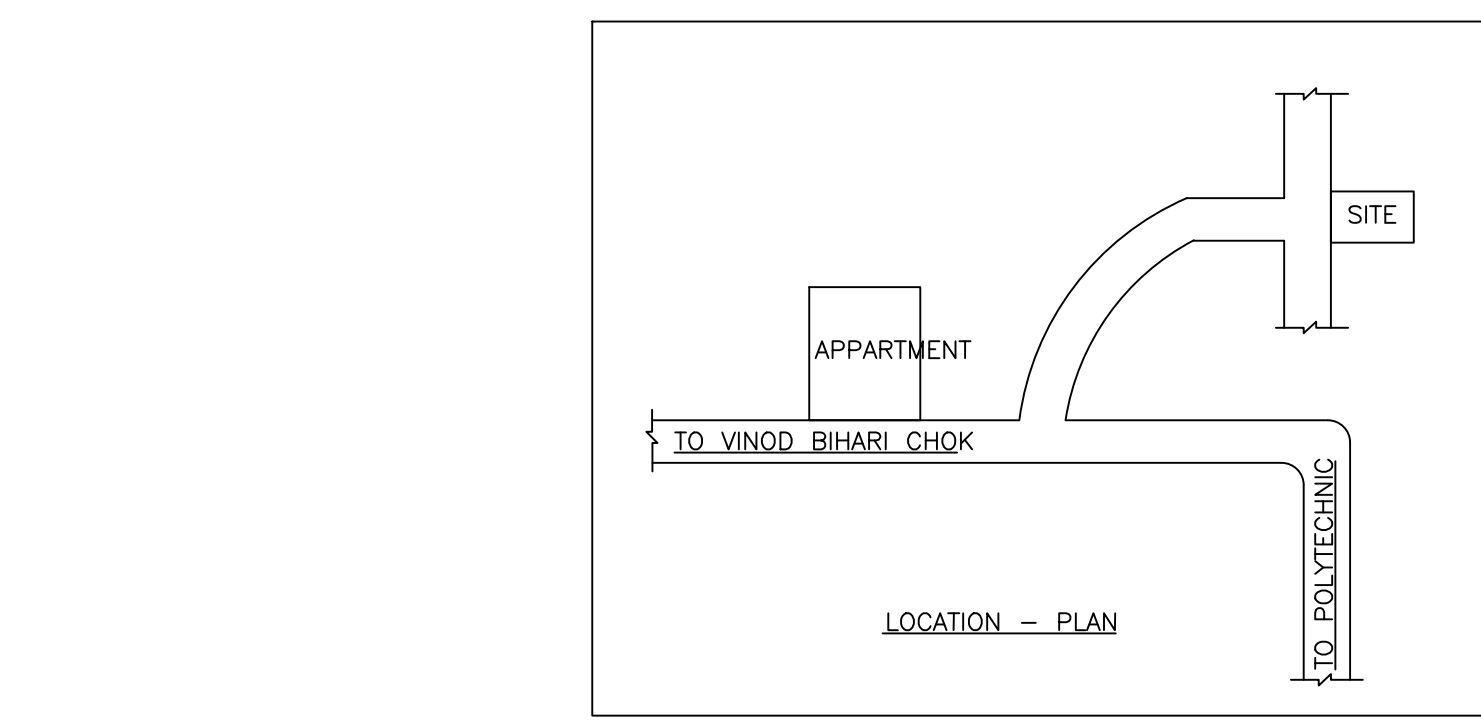

LOCATION - PLAN

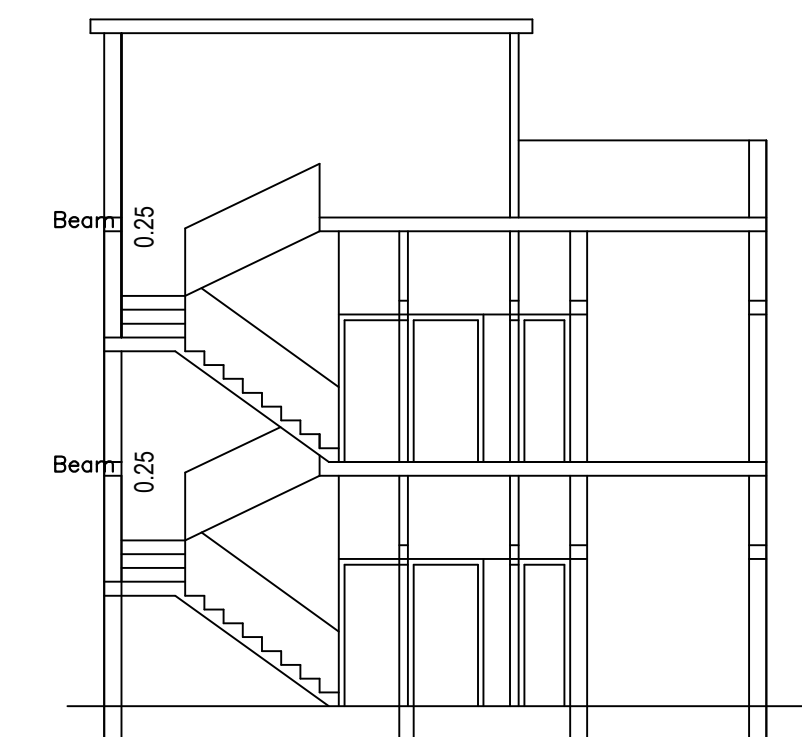

SECTION ON = X-X

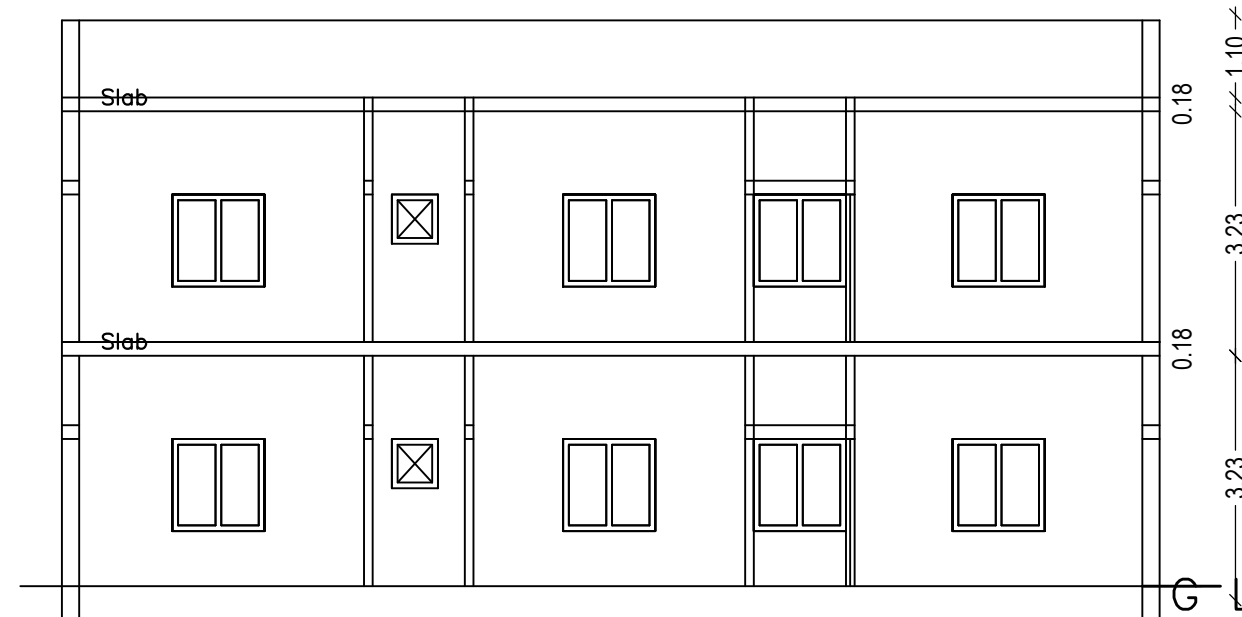

SECTION ON = Y-Y



FRONT ELEVATION

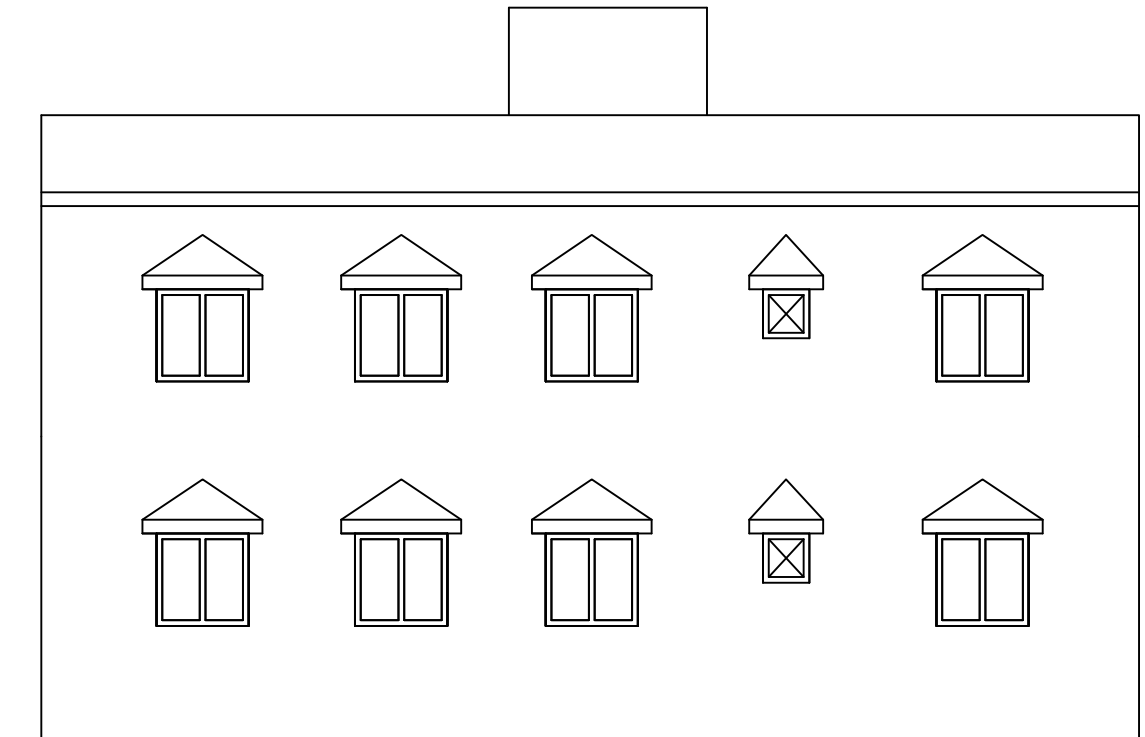

LEFT SIDE ELEVATION

Building USE/SUBUSE Details

Building Name	Building Use	Building SubUse	Building Structure
A (SMT ASHA DEVI)	Residential	Residential Bldg/Apartment	Non-Highrise

SCHEDULE OF DOOR:

BUILDING NAME	NAME	LENGTH	HEIGHT	NOS
A (SMT ASHA DEVI)	D	0.79	2.10	09
A (SMT ASHA DEVI)	D	1.00	2.10	12

SCHEDULE OF WINDOW/VENTILATION:

BUILDING NAME	NAME	LENGTH	HEIGHT	NOS
A (SMT ASHA DEVI)	W	0.61	1.20	08
A (SMT ASHA DEVI)	W	1.22	1.20	20
A (SMT ASHA DEVI)	W	1.28	1.20	02

UnitBUA Table for Building :A (SMT ASHA DEVI)

FLOOR	Name	UnitBUA Type	UnitBUA Area	Carpet Area	No. of Rooms	No. of Tenement
TYPICAL - FIRST FLOOR PLAN	SPLIT A	FLAT	0.00	0.00	11	0
GROUND FLOOR PLAN	SPLIT A	FLAT	254.39	254.02	10	1
Total	-	-	254.39	254.02	21	1

Proposal Basic Information

Proposal File No.	DMC/BP/0323/W22/2019
Owner Name	SMT ASHA DEVI
Khata No	29, NEW-308
Plot No	456, NEW-853
Village Name	Bisanpur
Use	Residential
SubUse	Bungalow/ Dwelling / Non Apartment

COLOR INDEX

PLOT BOUNDARY	Green
ABUTTING ROAD	Red
PROPOSED CONSTRUCTION	Yellow
COMMON PLOT	Blue
ROAD WIDENING AREA	Orange
EXISTING (To be retained)	Light Blue
EXISTING (To be demolished)	Dark Blue

Buildingwise Floor FAR Details

Floor Name	Building Name A (SMT ASHA DEVI)		Total	
	Proposed Built Up Area (Sq.mt.)	Proposed FAR Area (Sq.mt.)	Total Proposed Built Up Area (Sq.mt.)	Total FAR Area (Sq.mt.)
Ground Floor	127.19	127.19	127.19	127.19
First Floor	127.19	127.19	127.19	127.19
Terrace Floor	0.00	0.00	0.00	0.00
Total	254.38	254.38	254.38	254.38

FAR & Tenement Details (Table 4c-1)

Building	No. of Same Bldg	Total Built Up Area (Sq.mt.)	Proposed FAR Area (Sq.mt.)		Total Consumed Additional FAR Area (Sq.mt.)	Tnmt (No.)
			Resi.	Total FAR Area (Sq.mt.)		
A (SMT ASHA DEVI)	1	254.38	254.38	254.38	254.38	01
Grand Total	1	254.38	254.38	254.38	254.38	01

Building :A (SMT ASHA DEVI)

Floor Name	Total Built Up Area (Sq.mt.)	Proposed FAR Area (Sq.mt.)		Total Consumed Additional FAR Area (Sq.mt.)	Tnmt (No.)
		Resi.	Total FAR Area (Sq.mt.)		
Ground Floor	127.19	127.19	127.19	127.19	01
First Floor	127.19	127.19	127.19	127.19	00
Terrace Floor	0.00	0.00	0.00	0.00	00
Total	254.38	254.38	254.38	254.38	01
Total Number of Same Buildings	1				
Total	254.38	254.38	254.38	254.38	01

AREA STATEMENT
DHANBAD MUNICIPAL CORPORATION

Version No: 1.0.42	Version Date: 29/04/2019
Region: JHARKHAND URBAN LOCAL BODIES	Plot Use: Residential
District: DHANBAD	Plot SubUse: Bungalow/ Dwelling / Non Apartment
Authority: DHANBAD MUNICIPAL CORPORATION	PlotNearbyReligiousStructure: NA
Inward No: DMC/BP/0323/W22/2019	PlotSubPlot No: 456, NEW-853
Application Type: General Proposal	North: Plot No. - PART OF THIS PLOT
Project Type: Building Permission	South: Plot No. - PART OF THIS PLOT
Nature of Development: New	East: Plot No. - 850
Location of Development Area: Old Area	West: Road Width - 5.5

AREA DETAILS:		SQ.MT.
AREA OF PLOT (Minimum)	(A)	208.34
NET AREA OF PLOT(Gross Plot Area - Deduction from Gross Plot area)	(A-Deductions)	208.34
Deduction for Balance Plot Area(from Gross Plot Area)		
Common Plot		48.75
Total		48.75
BALANCE AREA OF PLOT(Net Plot Area - Recreational/Amenity space)	(A-Deductions)	159.59
PLOT AREA FOR COVERAGE(Net Plot Area)	(A-Deductions)	208.34
Plot Area for FAR (Net Plot Area + RoadWidening Area)	(A-Deductions)	208.34
COVERAGE CHECK		
Permissible Coverage area (70.00 %)		145.84
Proposed Coverage Area (61.05 %)		127.19
Total Prop. Coverage Area (61.05 %)		127.19
Balance coverage area (8.95 %)		18.65
FAR CHECK		
Perm. FAR Area (1.80)		375.01
Total Perm. FAR area		375.01
Residential FAR		254.39
Proposed FAR Area		254.39
Total Proposed FAR Area		254.39
Consumed FAR (Factor)		1.22
Balance FAR Area		120.62
BUILT UP AREA CHECK		
Total Proposed BuiltUp Area		254.38
ARCHITECT (Regd)	RAJEEV RANJAN SINGH	
ENGINEER (Regd)		
SUPERVISOR (Regd)		
OWNER (Regd)	SMT ASHA DEVI	
DEVELOPMENT AUTHORITY		LOCAL BODY

LTP NAME AND SIGNATURE	STRUCTURAL ENG'S NAME AND SIGNATURE	BUILDER NAME AND SIGNATURE	DIGITAL SIGNATURE
RAJEEV RANJAN SINGH DMC/ENG/0032/2017			

Proposal Basic Information

Proposal File No.	DMC/BP/0323/W22/2019
Owner Name	SMT ASHA DEVI
Khata No	29, NEW-308
Plot No	456, NEW-853
Village Name	Bisanpur
Use	Residential
SubUse	Bungalow/ Dwelling / Non Apartment

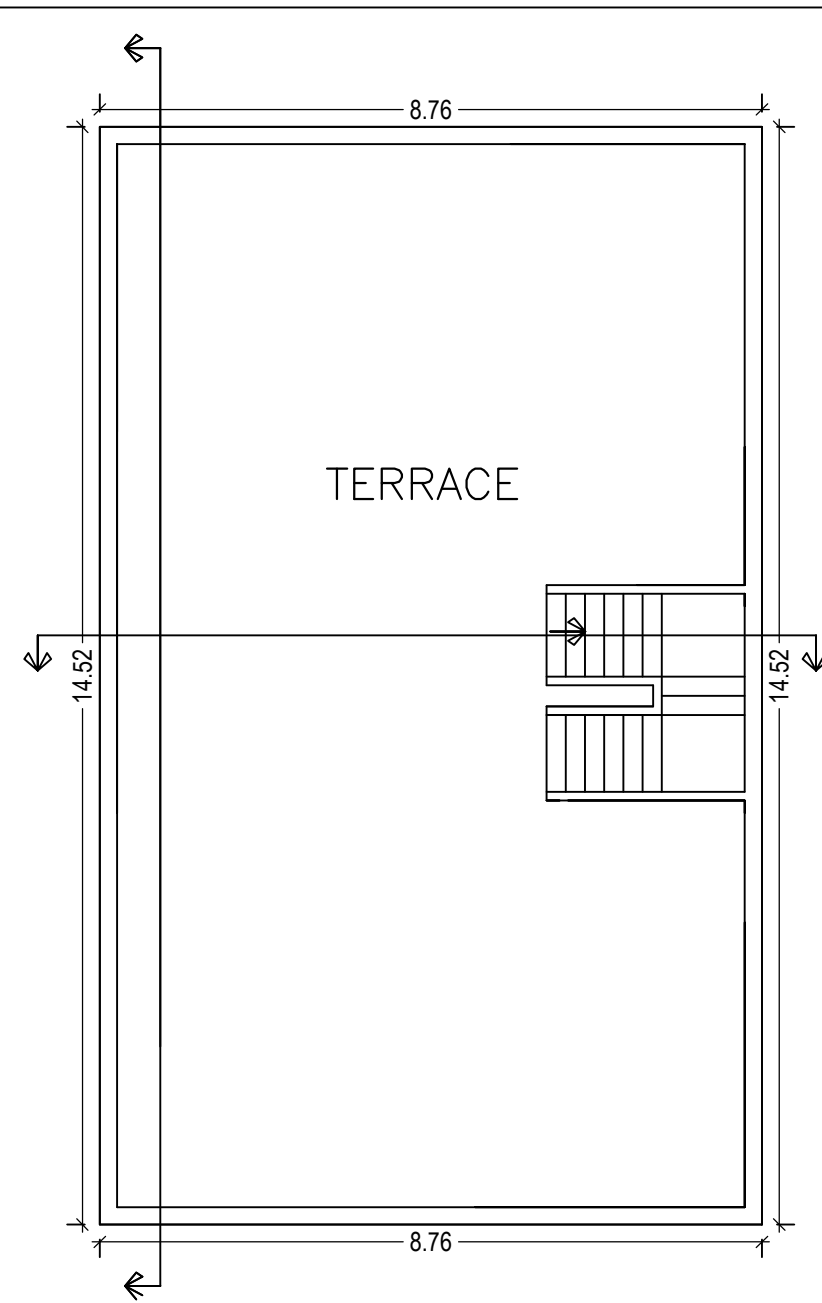

TERRACE FLOOR PLAN
(SCALE 1:100)

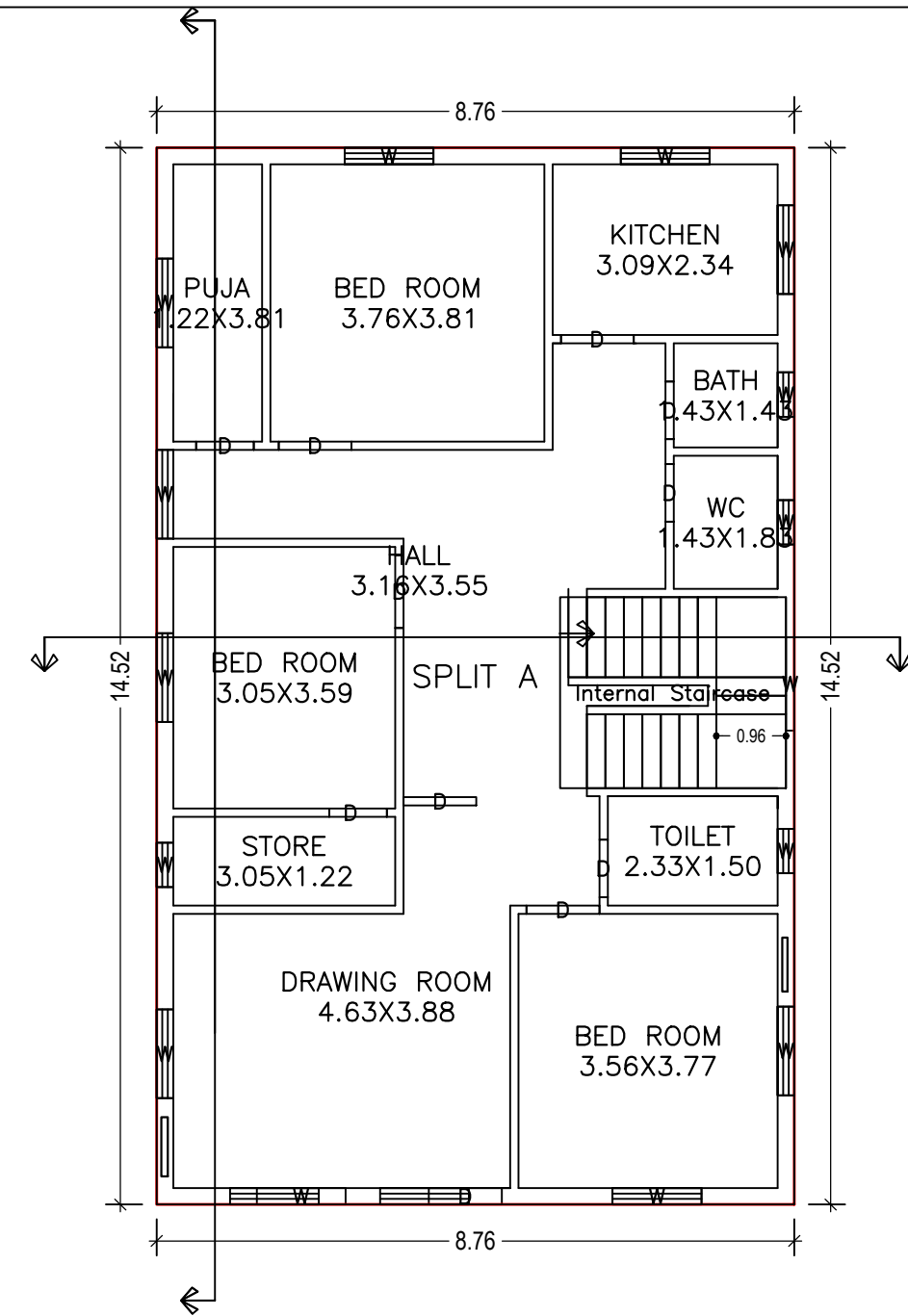

TYPICAL - FIRST FLOOR PLAN
(Proposed)
(SCALE 1:100)

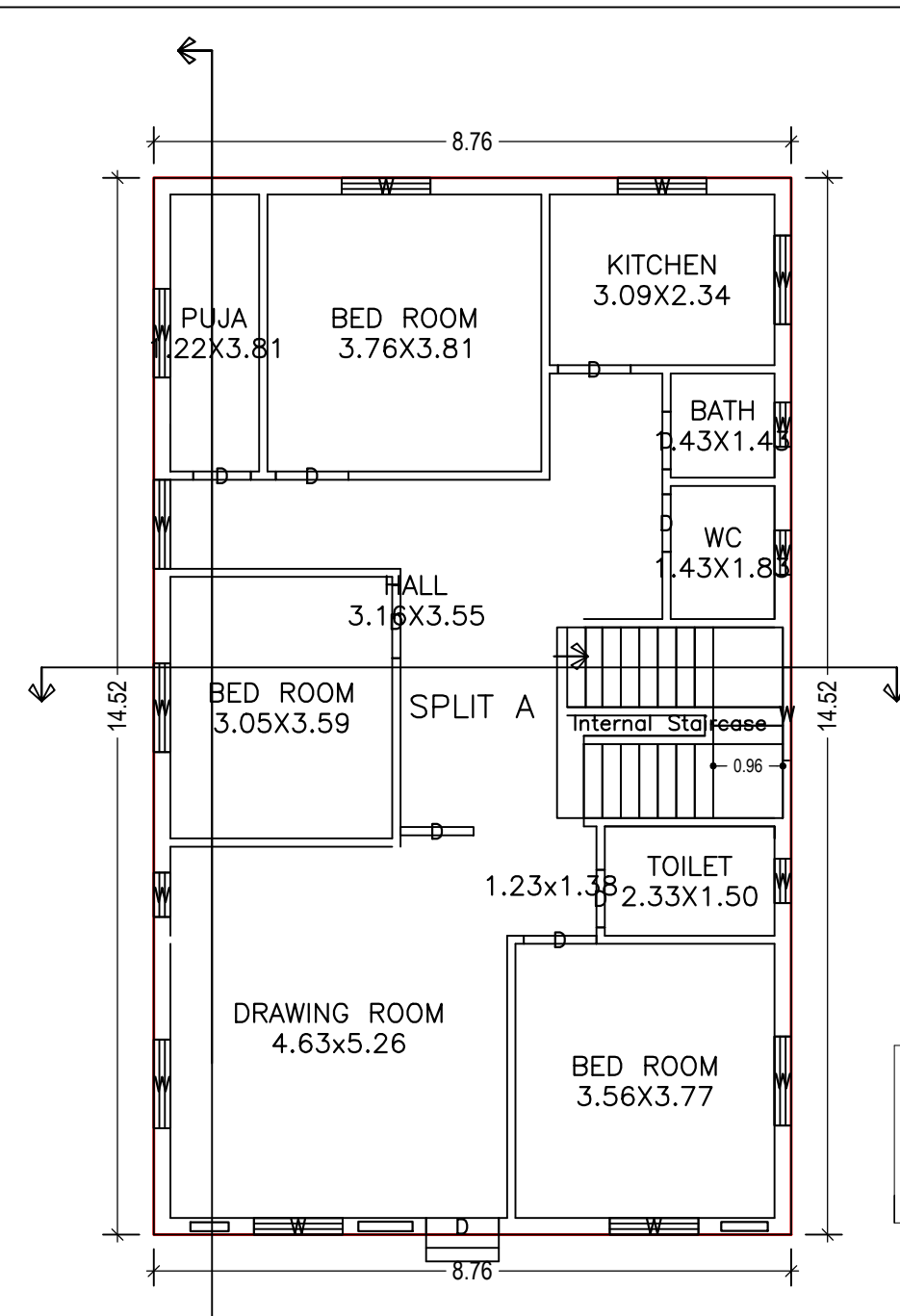

GROUND FLOOR PLAN
(Proposed)
(SCALE 1:100)

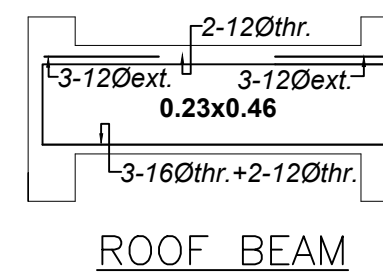

ROOF BEAM

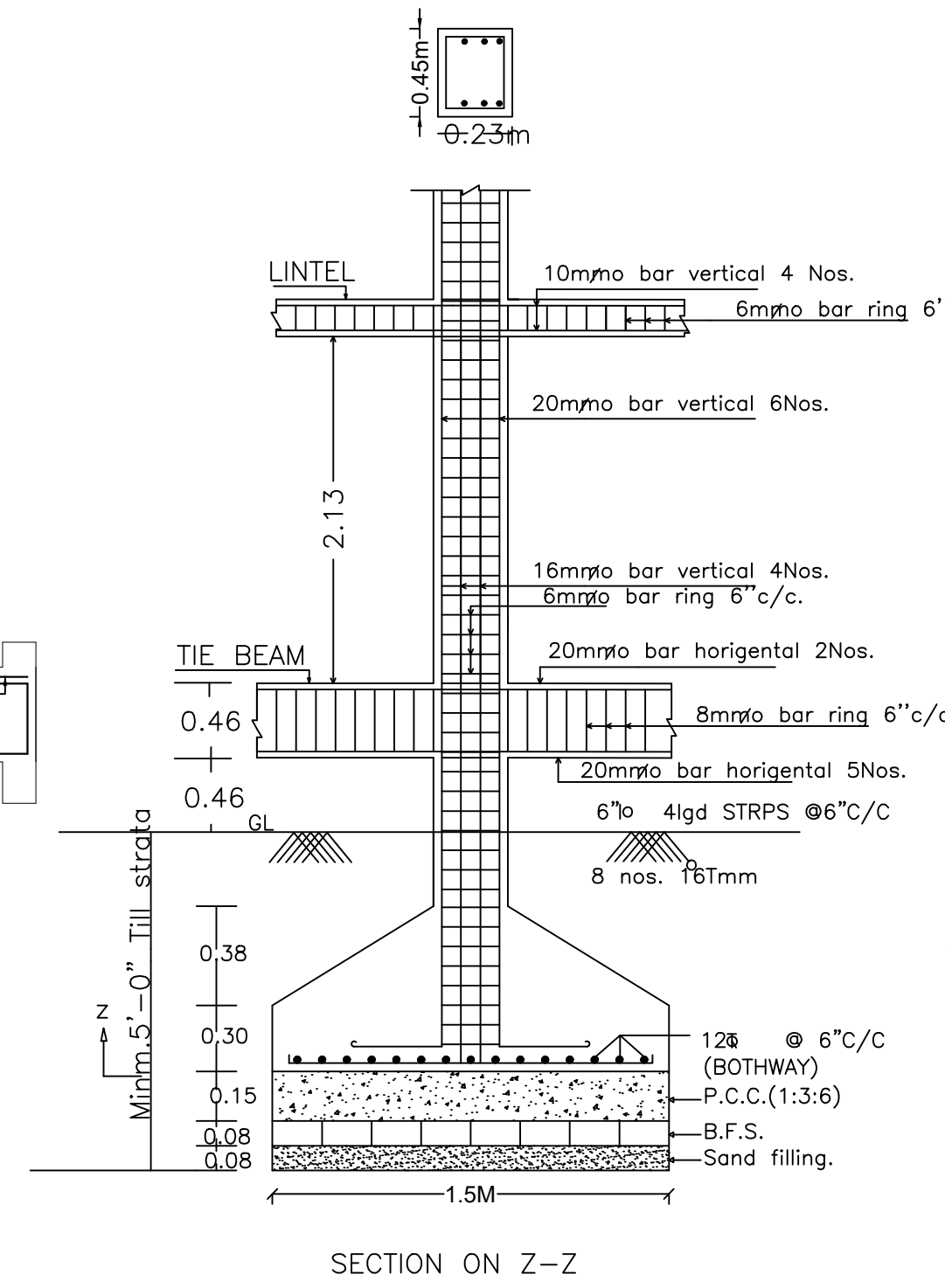

SECTION ON Z-Z

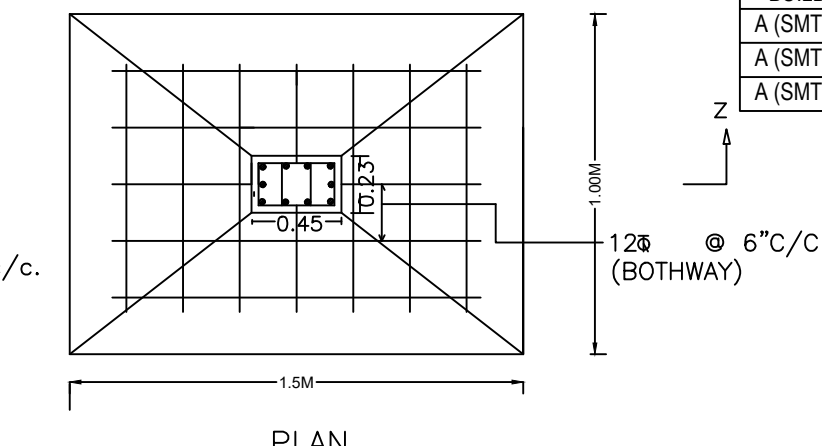

DETAIL OF COLUMNS

SCALE:- 1 = 200

SCHEDULE OF DOOR:

BUILDING NAME	NAME	LENGTH	HEIGHT	NOS
A (SMT ASHA DEVI)	D	0.79	2.10	09
A (SMT ASHA DEVI)	D	1.00	2.10	12

SCHEDULE OF WINDOW/VENTILATION:

BUILDING NAME	NAME	LENGTH	HEIGHT	NOS
A (SMT ASHA DEVI)	W	0.61	1.20	08
A (SMT ASHA DEVI)	W	1.22	1.20	20
A (SMT ASHA DEVI)	W	1.28	1.20	02

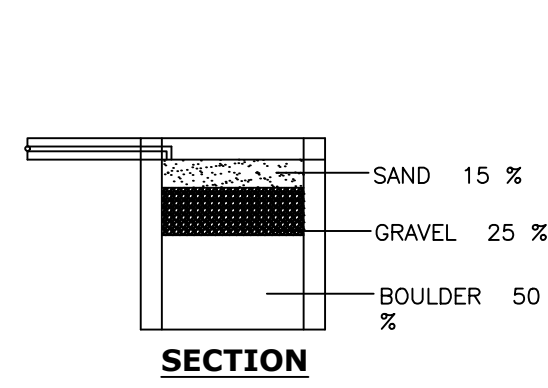

SECTION

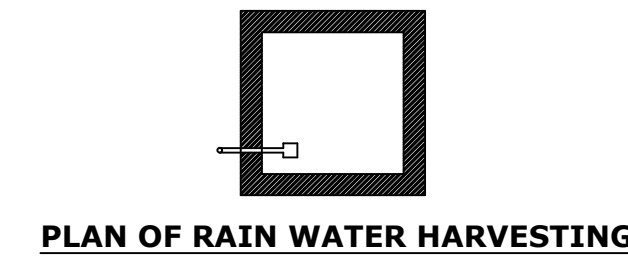

PLAN OF RAIN WATER HARVESTING

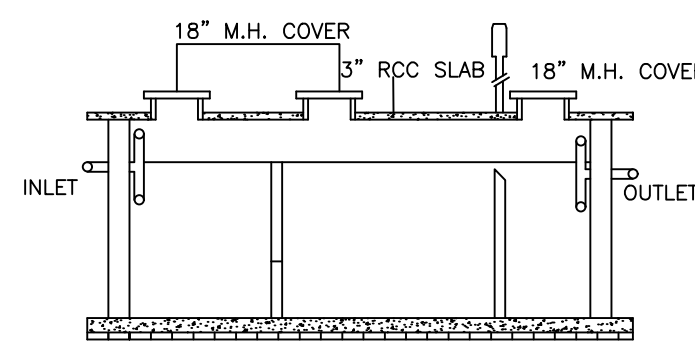

SECTION

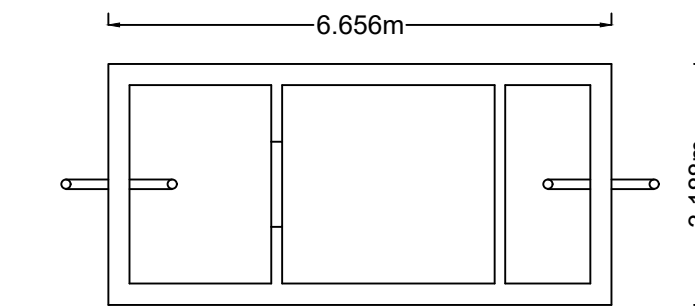

PLAN OF SEPTIC TANK



FRONT ELEVATION

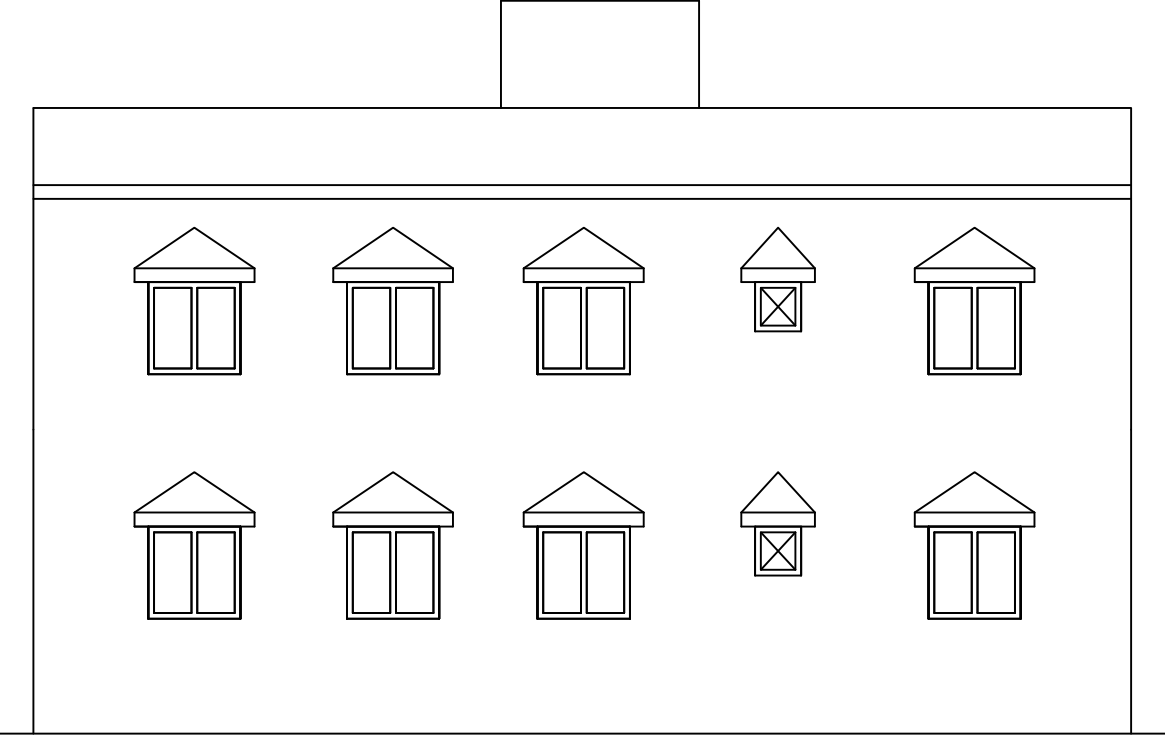

LEFT SIDE ELEVATION

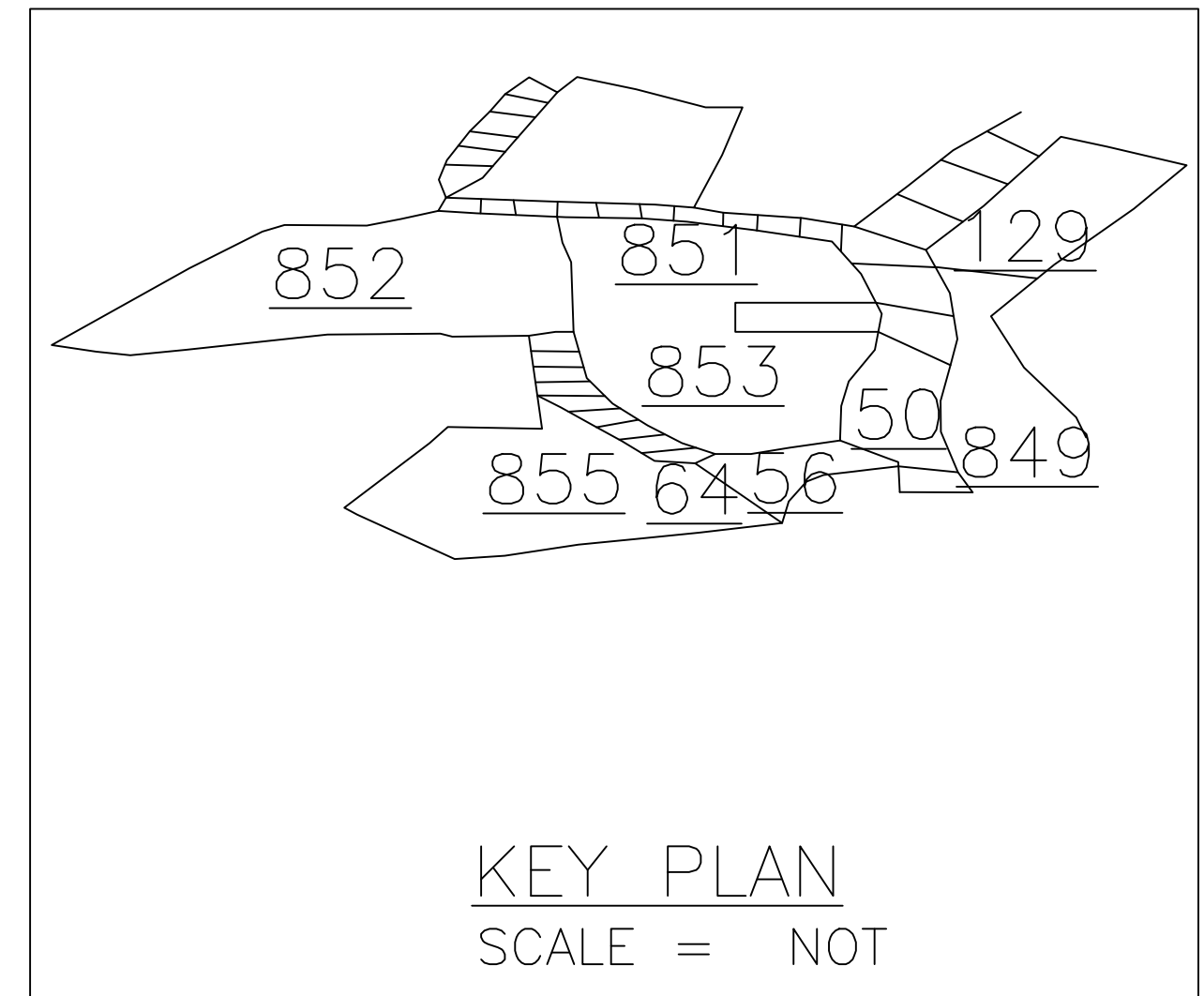

KEY PLAN

SCALE = NOT

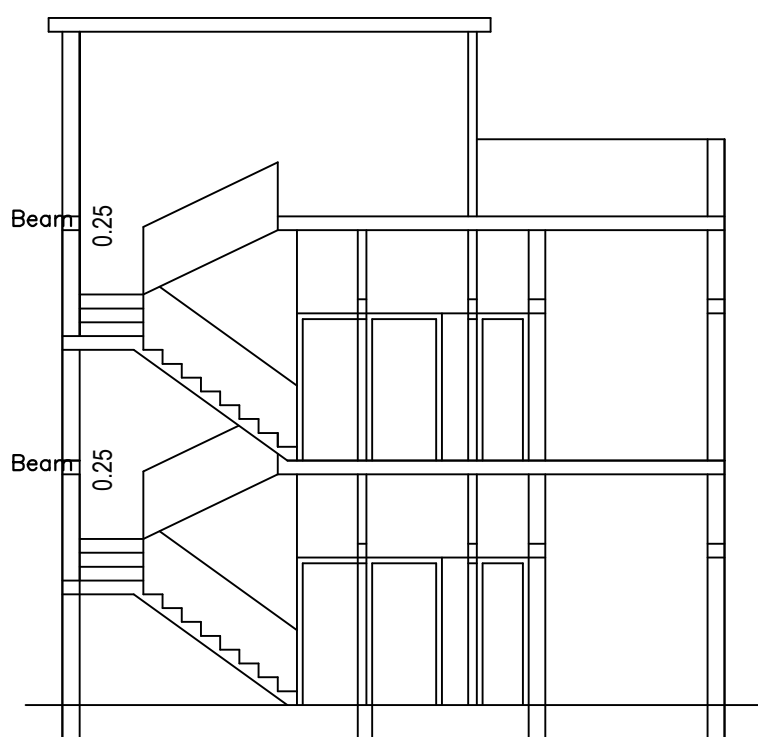

SECTION ON = X-X

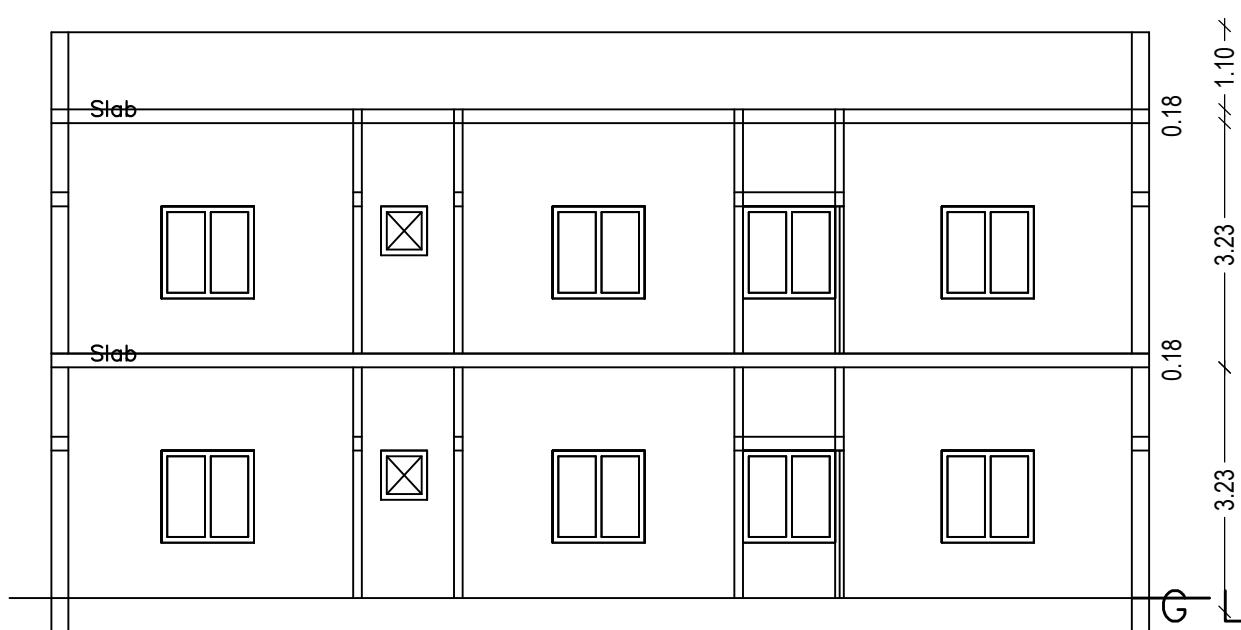

SECTION ON = Y-Y

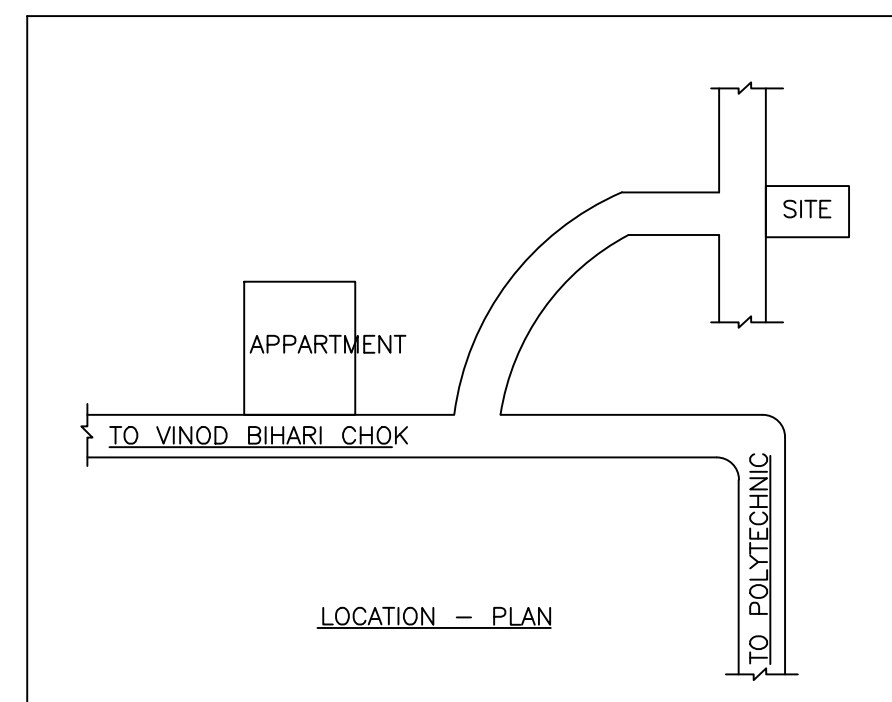

LOCATION - PLAN

LTP NAME AND SIGNATURE	STRUCTURAL ENG'S NAME AND SIGNATURE	BUILDER NAME AND SIGNATURE	DIGITAL SIGNATURE
RAJEEV RANJAN SINGH DMC/ENG/0032/2017			