

Proposal Basic Information	
Proposal File No.	DMC/BP/0329/W23/2019
Owner Name	SMT. PUSHPA KARMAKAR.
Khata No	30 (Old), 600 (New)
Plot No	1857 (Old), 2417 (New)
Village Name	Kolakusma
Use	Residential
SubUse	Bungalow/ Dwelling / Non Apartment

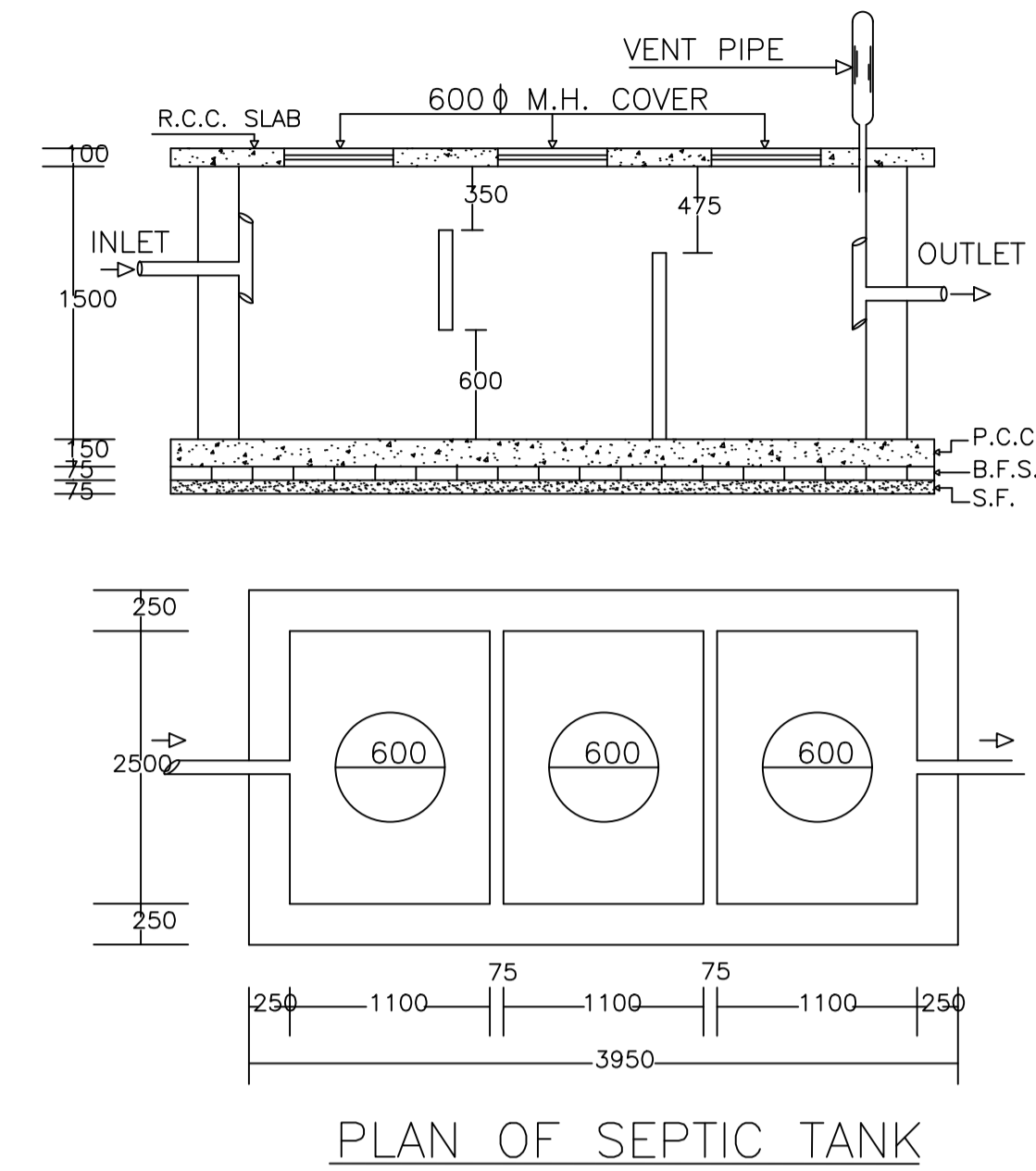

SITE PLAN

SITE PLAN

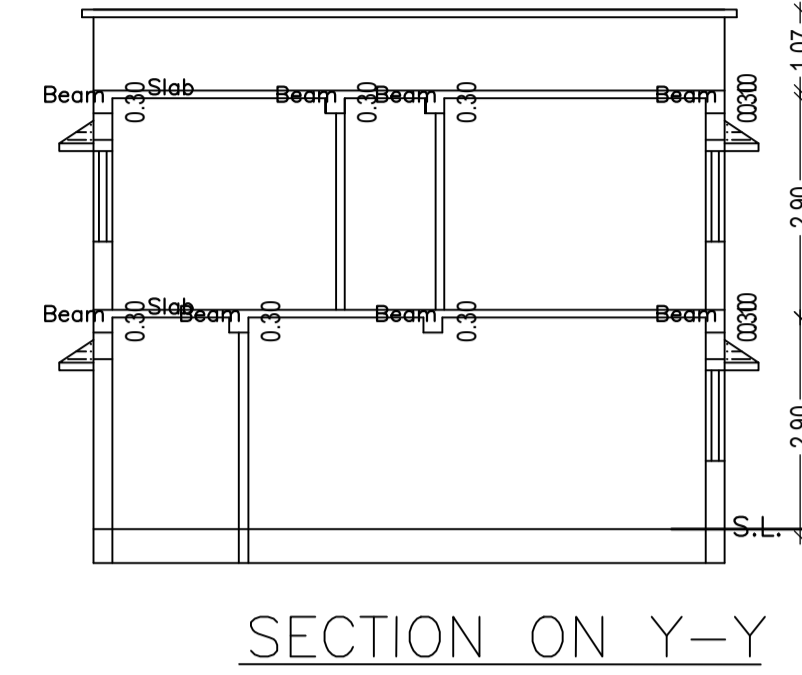
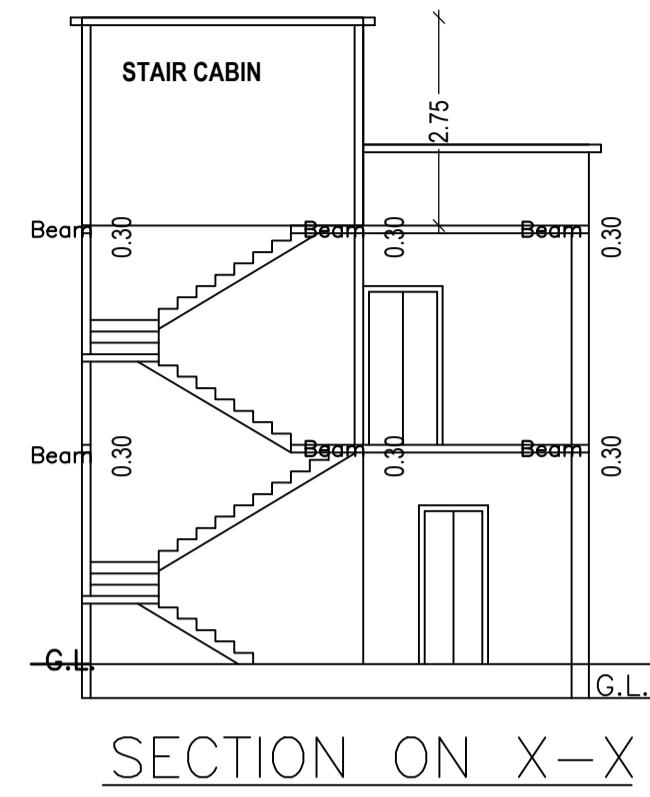
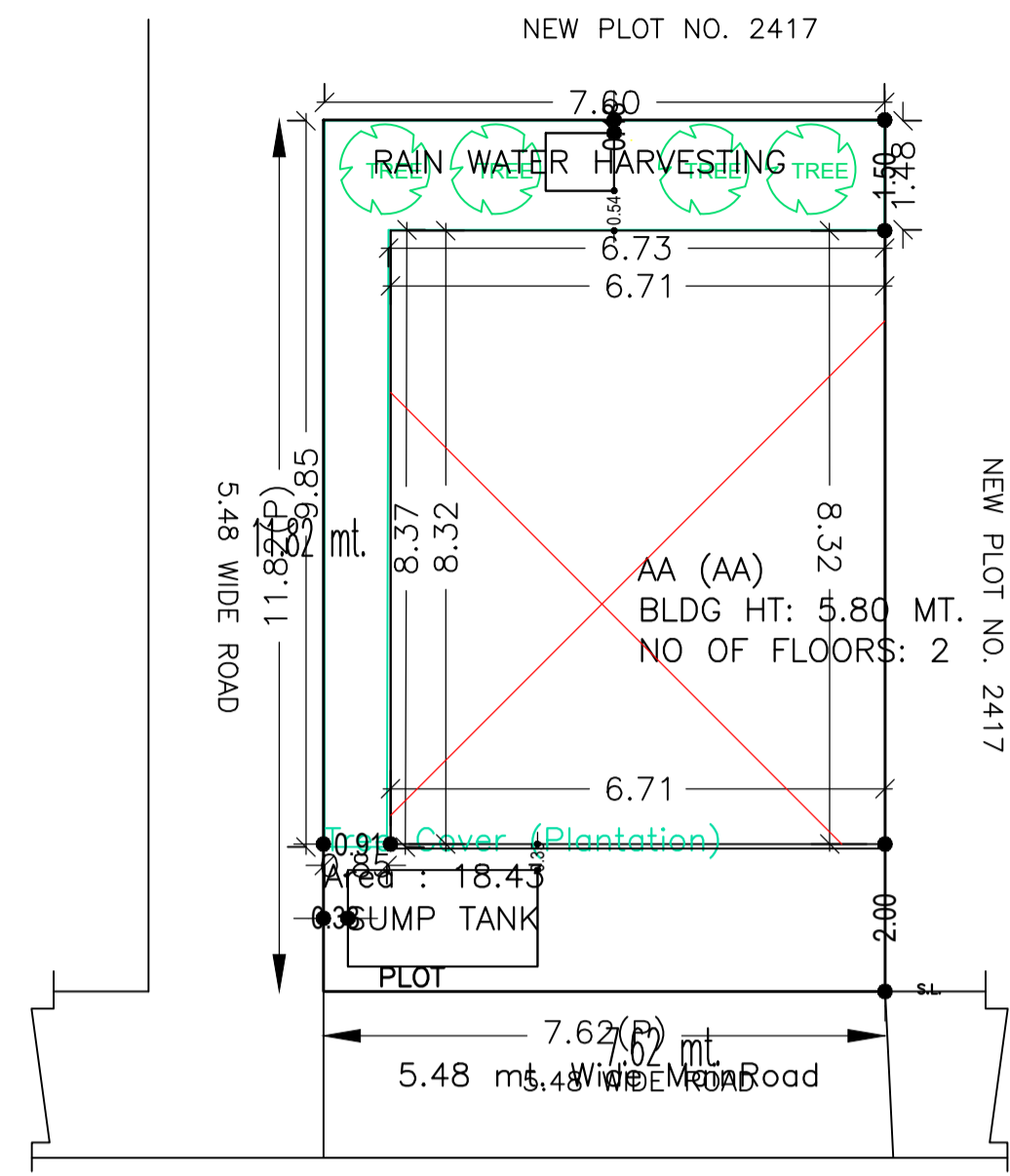
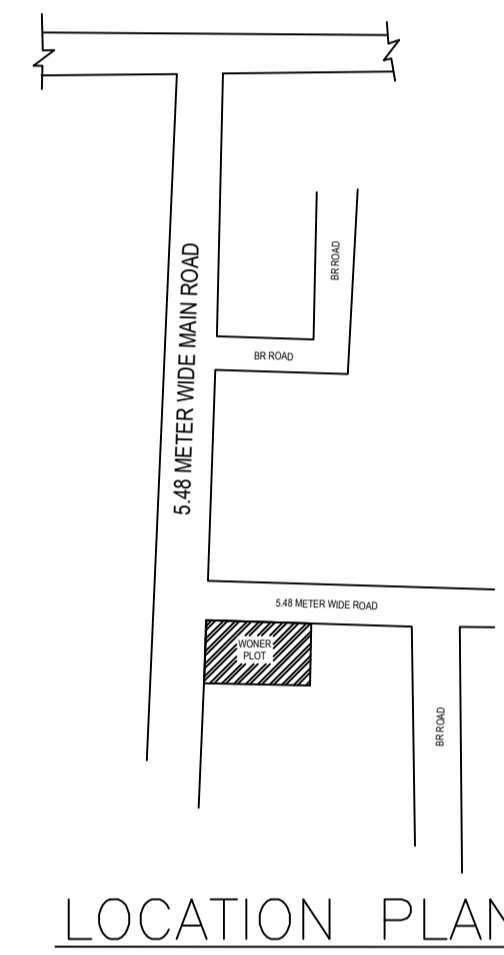
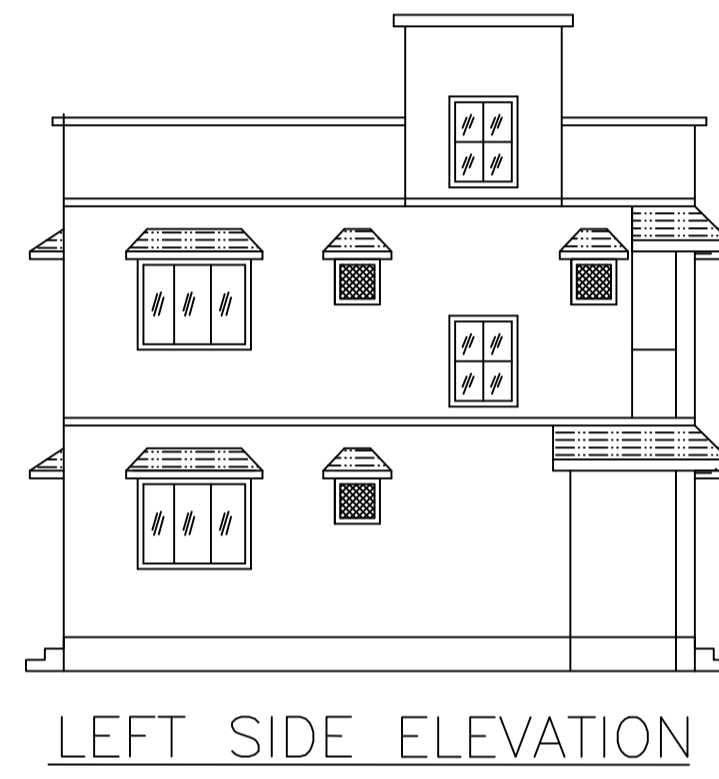
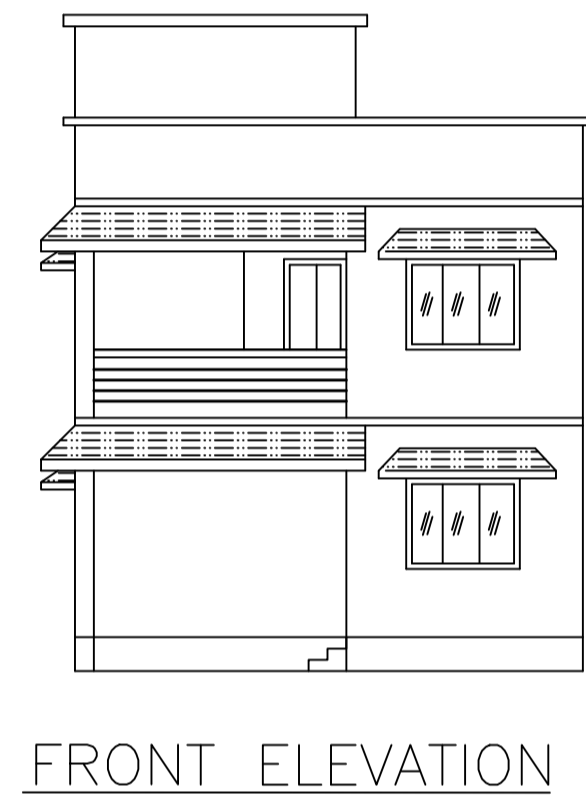
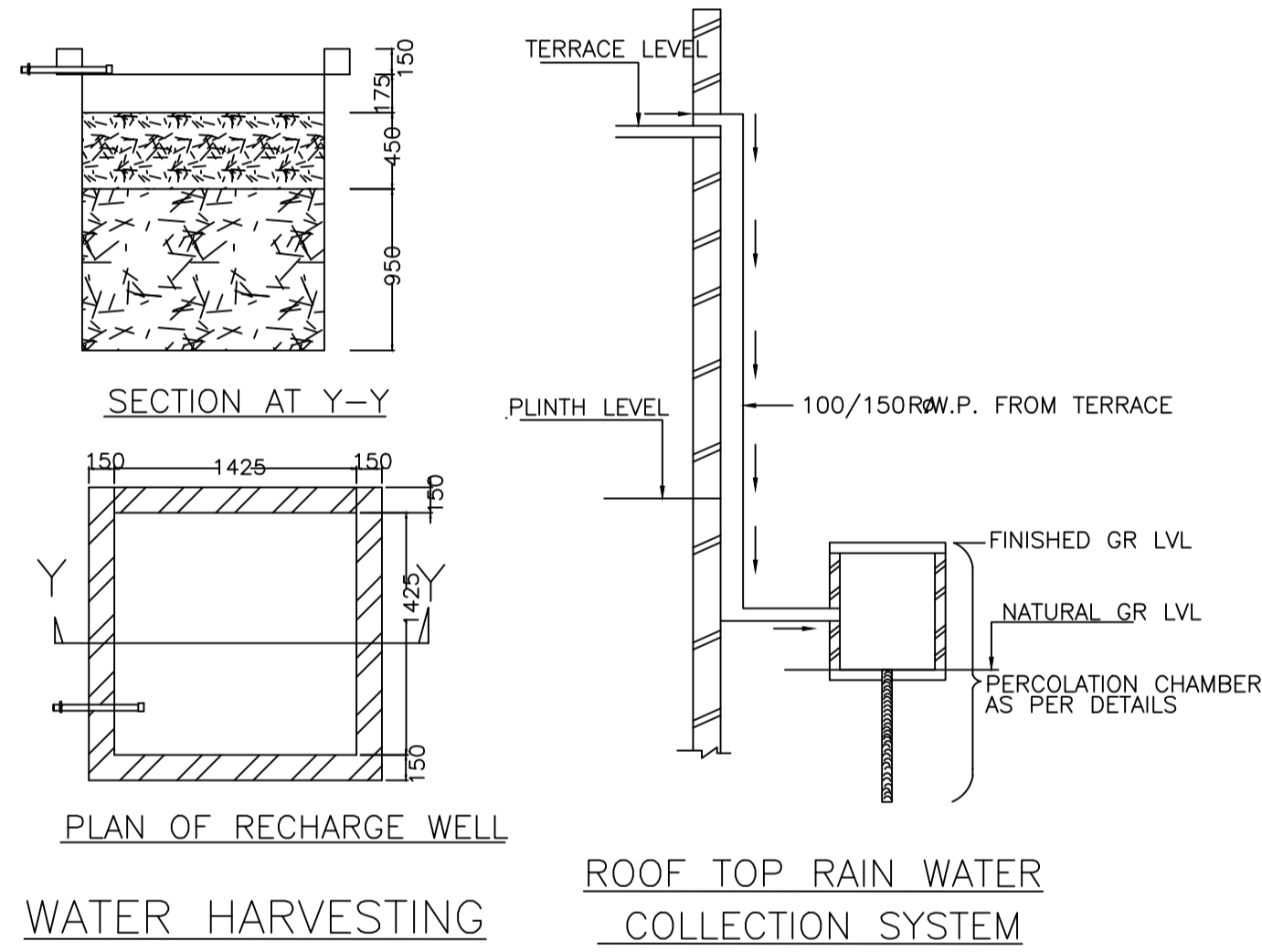

SCHEDULE OF DOOR:

BUILDING NAME	NAME	LENGTH	HEIGHT	NOS
AA (AA)	D	0.76	2.10	02
AA (AA)	D	0.83	2.10	01
AA (AA)	D	0.84	2.10	02
AA (AA)	D	0.91	2.10	02
AA (AA)	D	1.03	2.10	01
AA (AA)	D	1.05	2.10	03
AA (AA)	D	1.31	2.10	01
AA (AA)	D	1.81	2.10	01

SCHEDULE OF WINDOW/VENTILATION:

BUILDING NAME	NAME	LENGTH	HEIGHT	NOS
AA (AA)	W	0.60	1.20	03
AA (AA)	W	0.90	1.20	01
AA (AA)	W	1.50	1.20	08

Building :AA (AA)

Floor Name	Total Built Up Area (Sq.mt.)	Proposed FAR Area (Sq.mt.) Resi.	Total FAR Area (Sq.mt.)	Total Consumed Additional FAR Area (Sq.mt.)	Tnmt (No.)
Ground Floor	55.81	55.81	55.81	55.81	01
First Floor	55.81	55.81	55.81	55.81	00
Terrace Floor	0.00	0.00	0.00	0.00	00
Total :	111.62	111.62	111.62	111.62	01
Total Number of Same Buildings :	1				
Total :	111.62	111.62	111.62	111.62	01

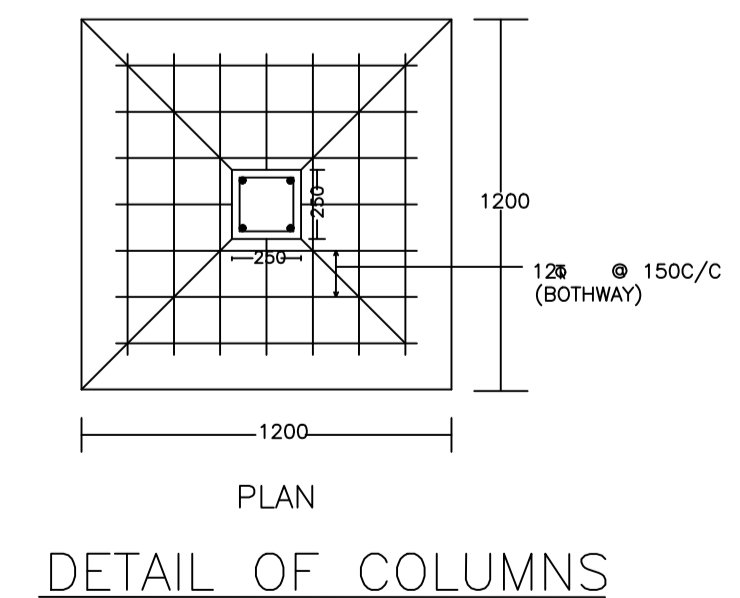
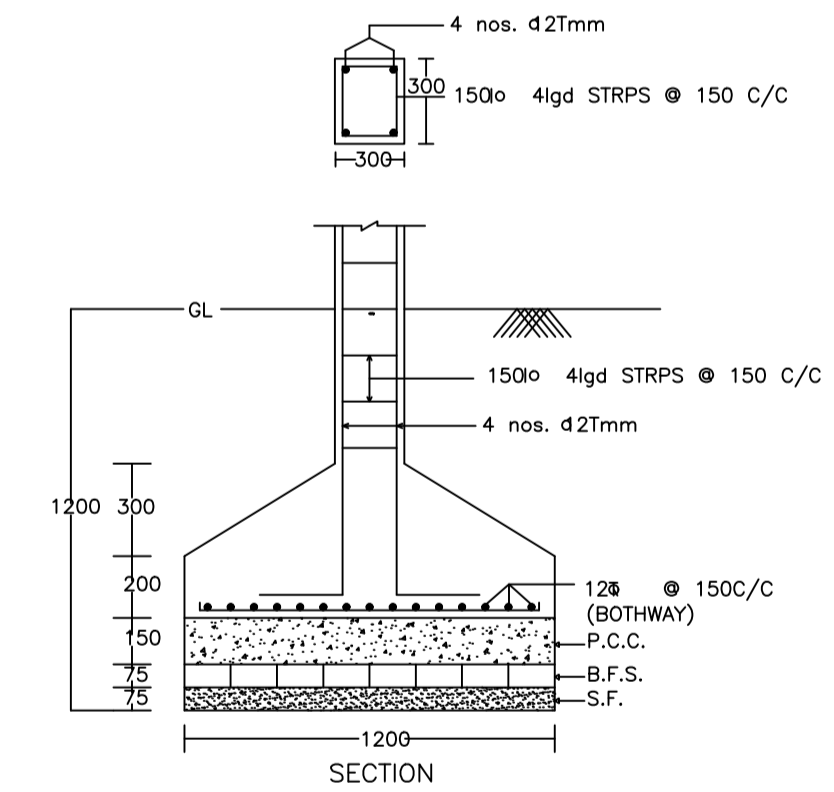
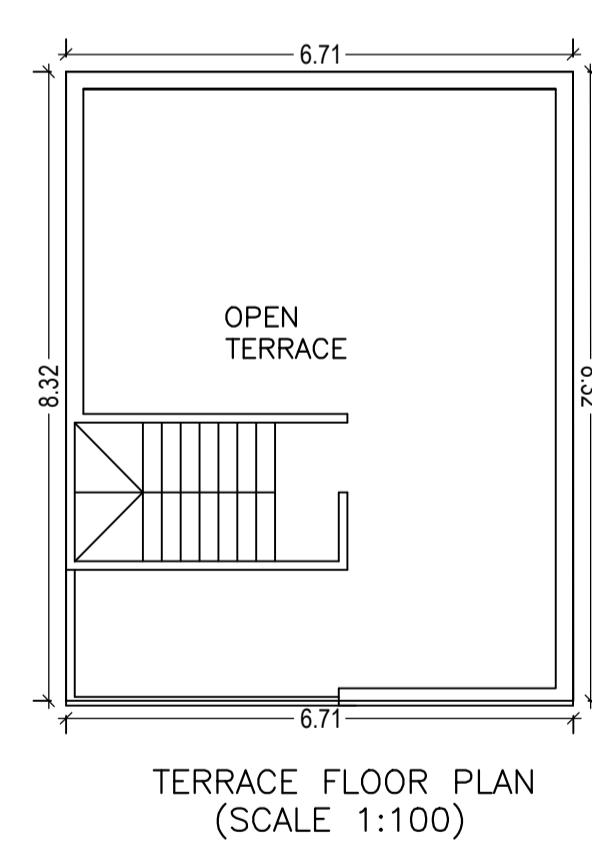
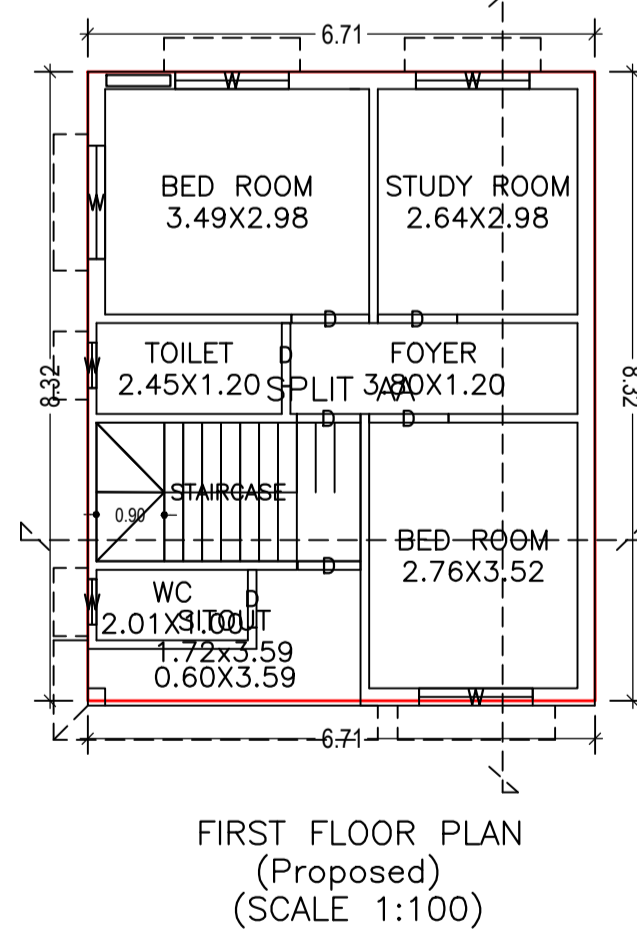
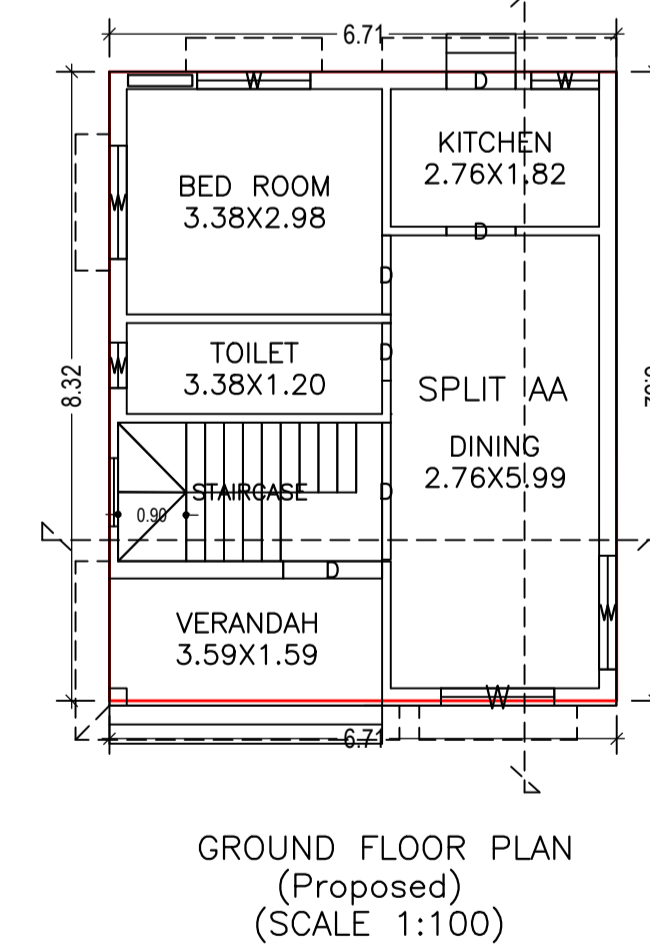
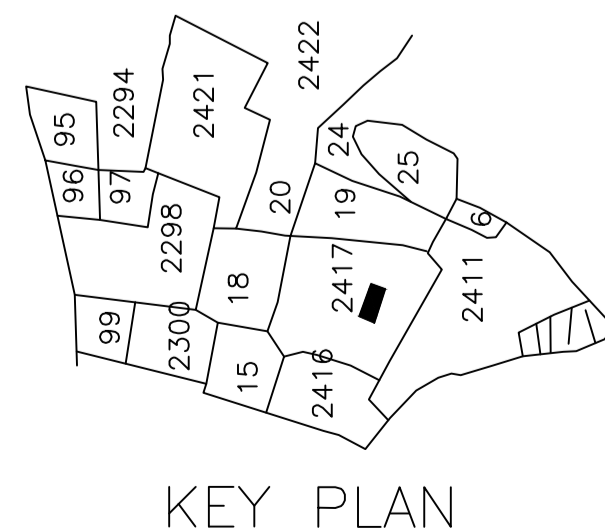

AREA STATEMENT		VERSION NO. : 1.0.43
DHANBAD MUNICIPAL CORPORATION		VERSION DATE: 29/04/2019
PROJECT DETAIL:		
Region: JHARKHAND URBAN LOCAL BODIES	Plot Use: Residential	
District: DHANBAD	Plot SubUse: Bungalow/ Dwelling / Non Apartment	
Authority: DHANBAD MUNICIPAL CORPORATION	Plot/Nearby/Religious/Structure: NA	
Inward No: DMC/BP/0329/W23/2019	Plot/SubPlot No: 1857 (Old), 2417 (New)	
Application Type: General Proposal	North: Road Width - 5.48	
Project Type: Building Permisson	South: Plot No - NEW PLOT NO - 2417 (P)	
Nature of Development: New	East: Plot No - NEW PLOT NO - 2417 (P)	
Location of Development Area: Old Area	West: Road Width - 5.48	
AREA DETAILS:		
AREA OF PLOT (Minimum)	(A)	SQ.MT. 90.07
NET AREA OF PLOT(Gross Plot Area - Deduction from Gross Plot area)	(A-Deductions)	90.07
Deduction for Balance Plot Area(from Gross Plot Area)		
Common Plot		18.43
Total		18.43
BALANCE AREA OF PLOT(Net Plot Area - Recreational/Amenity space)	(A-Deductions)	71.64
PLOT AREA FOR COVERAGE(Net Plot Area)	(A-Deductions)	90.07
Plot Area for FAR (Net Plot Area + RoadWidening Area)	(A-Deductions)	90.07
COVERAGE CHECK		
Permissible Coverage area (70.00 %)		63.05
Proposed Coverage Area (61.96 %)		55.81
Total Prop. Coverage Area (61.96 %)		55.81
Balance coverage area (8.04 %)		7.24
FAR CHECK		
Perm. FAR Area (1.80)		162.13
Total Perm. FAR area		162.13
Residential FAR		111.62
Proposed FAR Area		111.62
Total Proposed FAR Area		111.62
Consumed FAR (Factor)		1.24
Balance FAR Area		50.51
BUILT UP AREA CHECK		
Total Proposed BuiltUp Area		111.62
ARCHITECT (Regd)		PARTHA - PAL
ENGINEER (Regd)		
SUPERVISOR (Regd)		
OWNER (Regd)		SMT. PUSHPA KARMAKAR.
DEVELOPMENT AUTHORITY		LOCAL BODY

COLOR INDEX	
PLOT BOUNDARY	Black
ABUTTING ROAD	Red
PROPOSED CONSTRUCTION	Green
COMMON PLOT	Yellow
ROAD WIDENING AREA	Orange
EXISTING (To be retained)	Blue
EXISTING (To be demolished)	Light Blue

Buildingwise Floor FAR Details

Floor Name	Building Name		Total	
	Proposed Built Up Area (Sq.mt.)	Proposed FAR Area (Sq.mt.)	Total Proposed Built Up Area (Sq.mt.)	Total FAR Area (Sq.mt.)
Ground Floor	55.81	55.81	55.81	55.81
First Floor	55.81	55.81	55.81	55.81
Terrace Floor	0.00	0.00	0.00	0.00
Total :	111.62	111.62	111.62	111.62

Building USE/SUBUSE Details

Building Name	Building Use	Building SubUse	Building Structure
AA (AA)	Residential	Bungalow/ Dwelling / Non Apartment	Non-Highrise

FAR & Tenement Details (Table 4c-1)

Building	No. of Same Bldg	Total Built Up Area (Sq.mt.)	Proposed FAR Area (Sq.mt.) Resi.	Total FAR Area (Sq.mt.)	Total Consumed Additional FAR Area (Sq.mt.)	Tnmt (No.)
AA (AA)	1	111.62	111.62	111.62	111.62	01
Grand Total :	1	111.62	111.62	111.62	111.62	01

UnitBUA Table for Building :AA (AA)

FLOOR	Name	UnitBUA Type	UnitBUA Area	Carpet Area	No. of Rooms	No. of Tenement
GROUND FLOOR PLAN	SPLIT AA	FLAT	111.62	111.37	5	1
FIRST FLOOR PLAN	SPLIT AA	FLAT	0.00	0.00	7	0
Total:	-	-	111.62	111.37	12	1

LTP NAME AND SIGNATURE	STRUCTURAL ENG'S NAME AND SIGNATURE	BUILDER NAME AND SIGNATURE	DIGITAL SIGNATURE
PARTHA - PAL DMC/ENG/0021/2016			