

Proposal File No.	DMC/BP/0331/W23/2019
Owner Name	SMT. POONAM KUMARI SINGH.
Khata No	30 ( Old ), 600 ( New )
Plot No	1857 ( Old ), 2417 ( New )
Village Name	Kolakusma
Use	Residential
SubUse	Bungalow/ Dwelling / Non Apartment

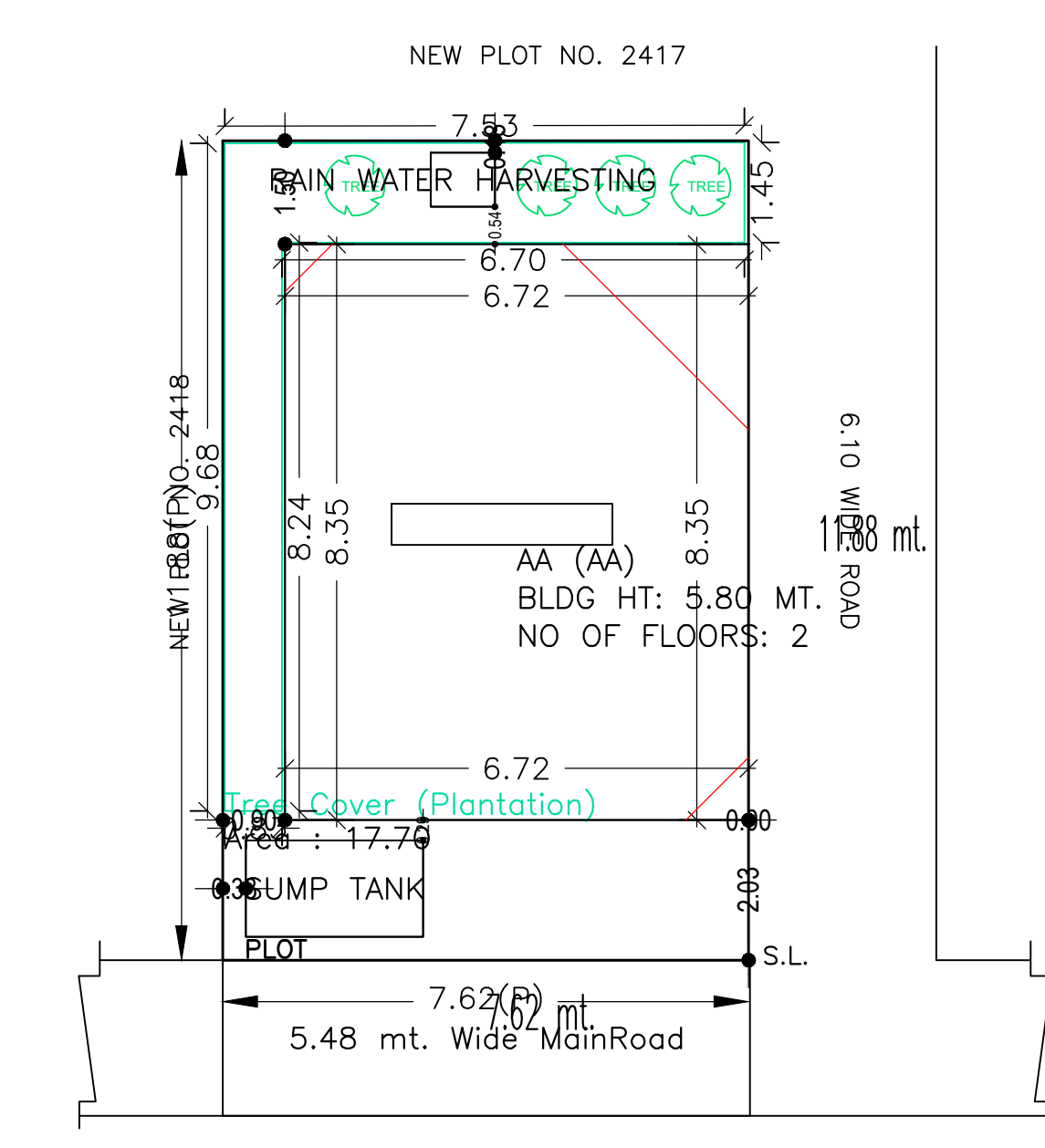

SITE PLAN

SITE PLAN

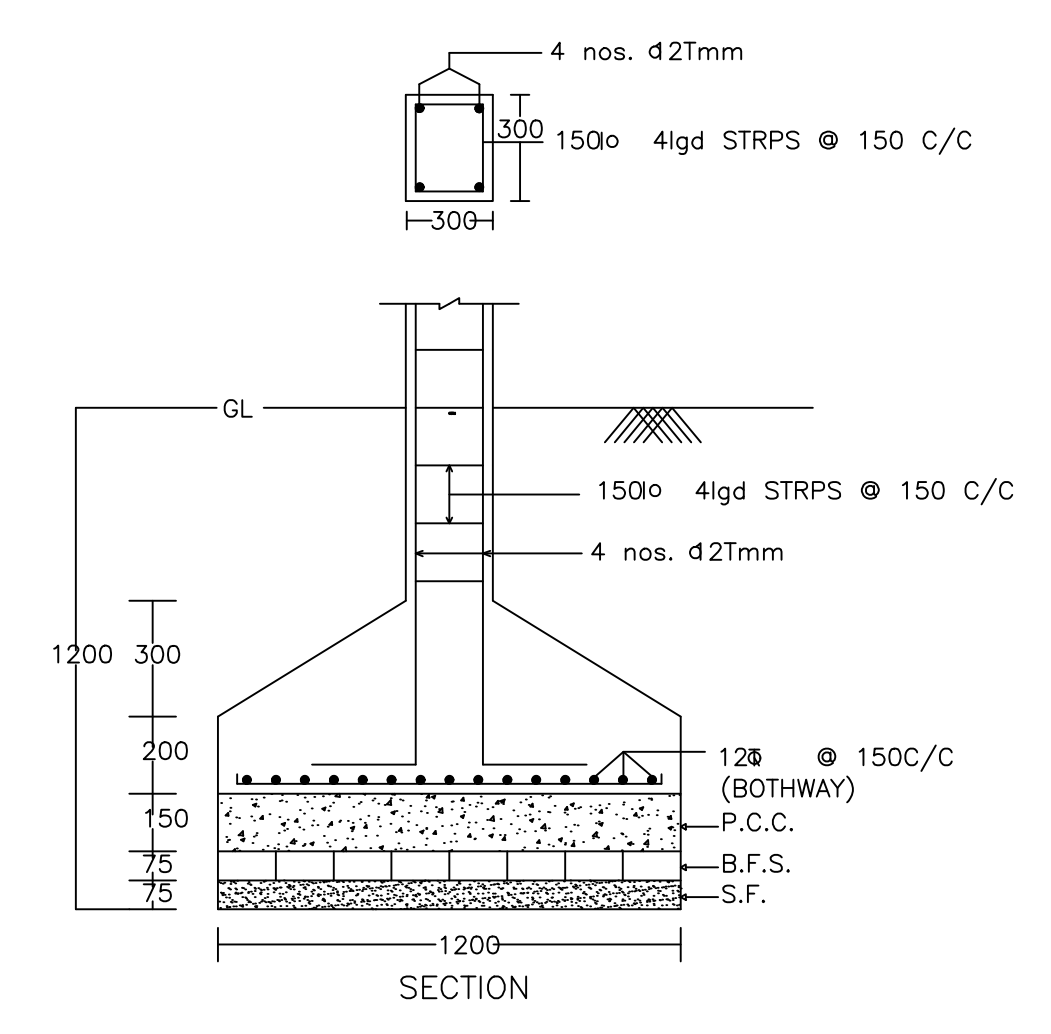

SECTION

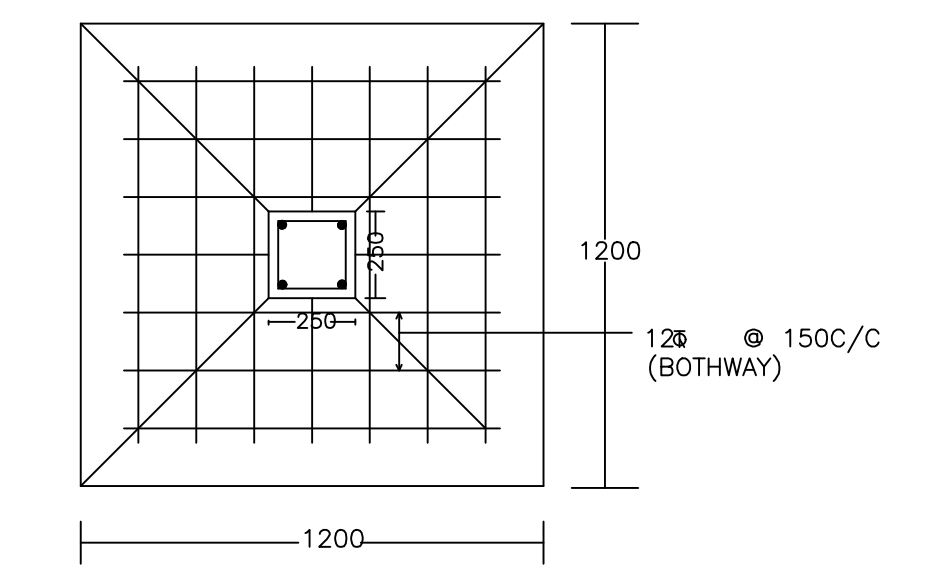

PLAN

DETAIL OF COLUMNS

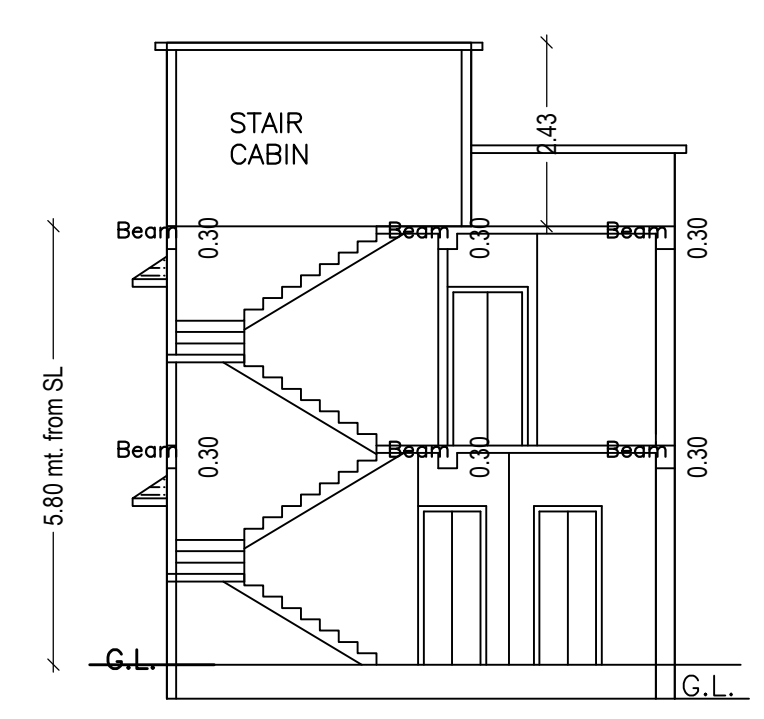

SECTION ON X-X

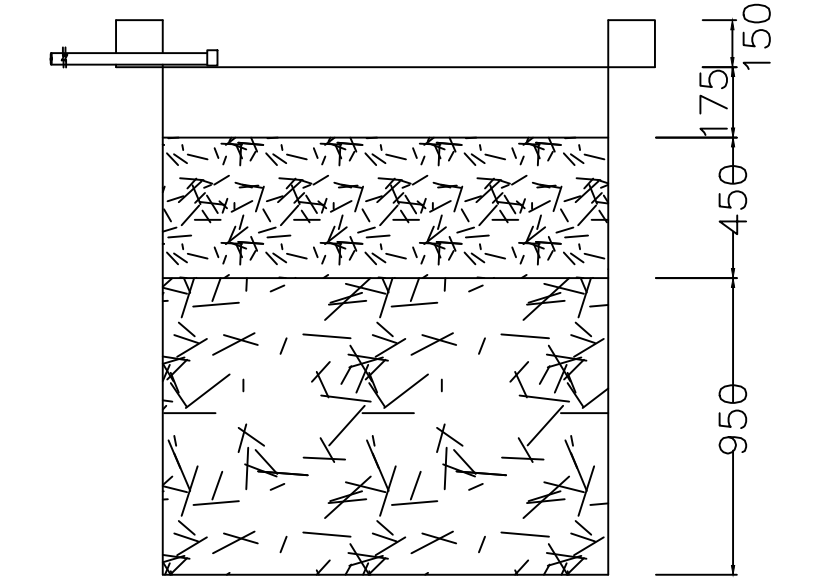

SECTION AT Y-Y

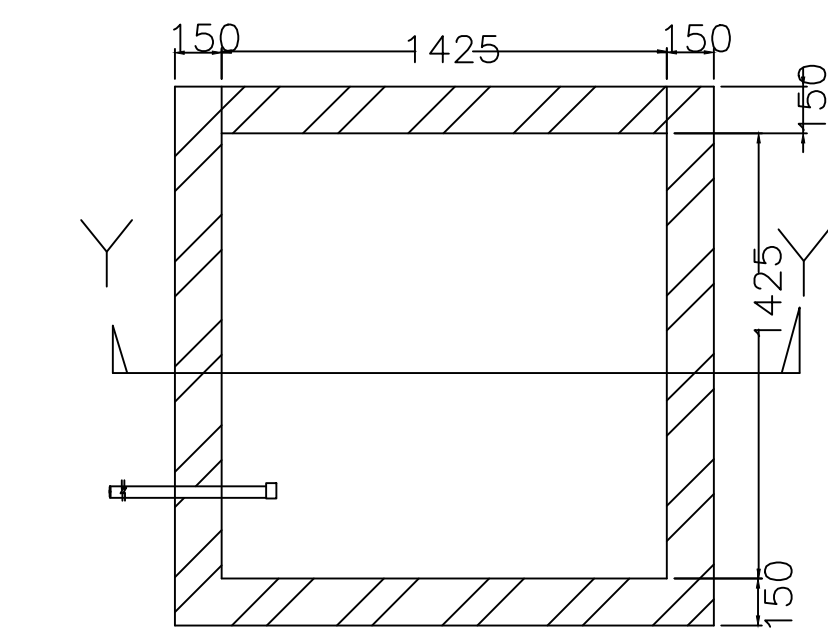

PLAN OF RECHARGE WELL

WATER HARVESTING

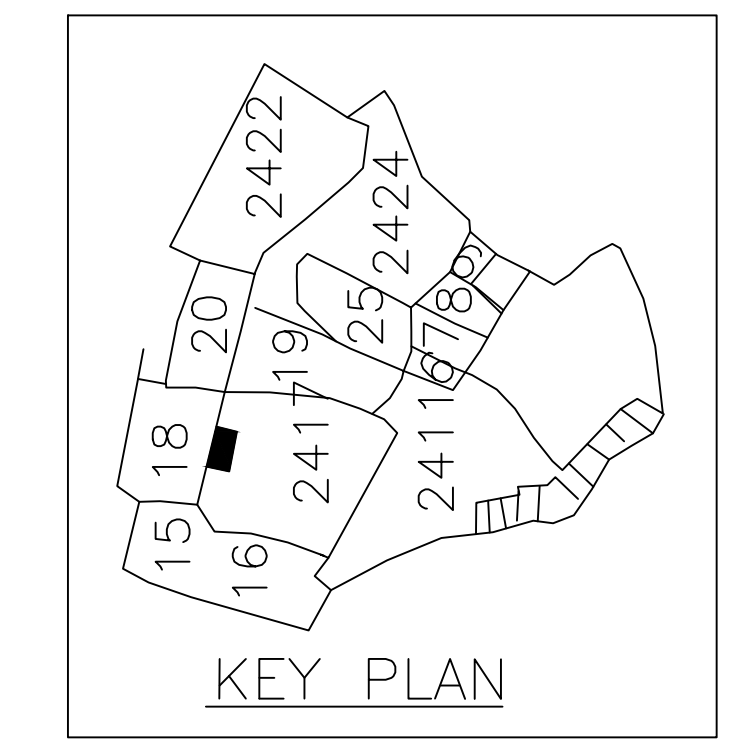

KEY PLAN

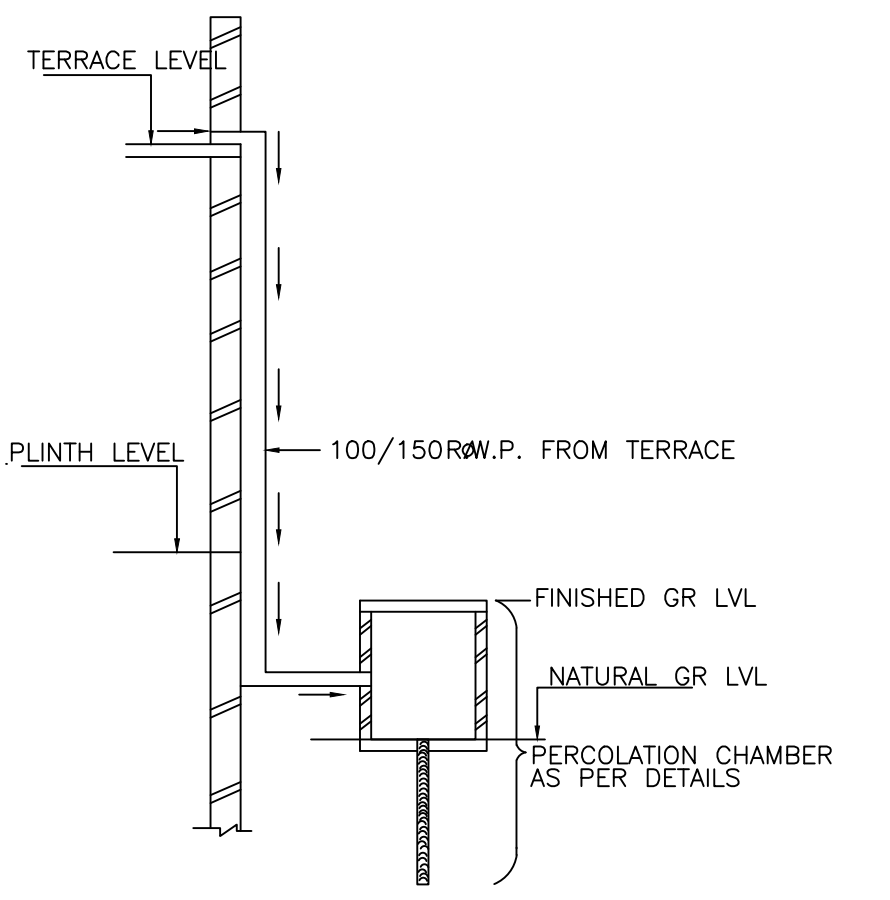

ROOF TOP RAIN WATER COLLECTION SYSTEM

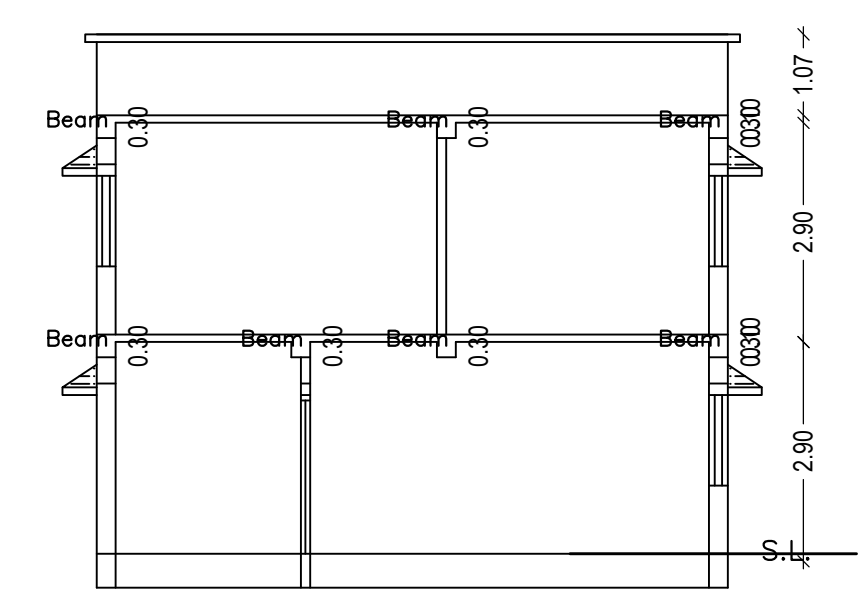

SECTION ON Y-Y



LEFT SIDE ELEVATION

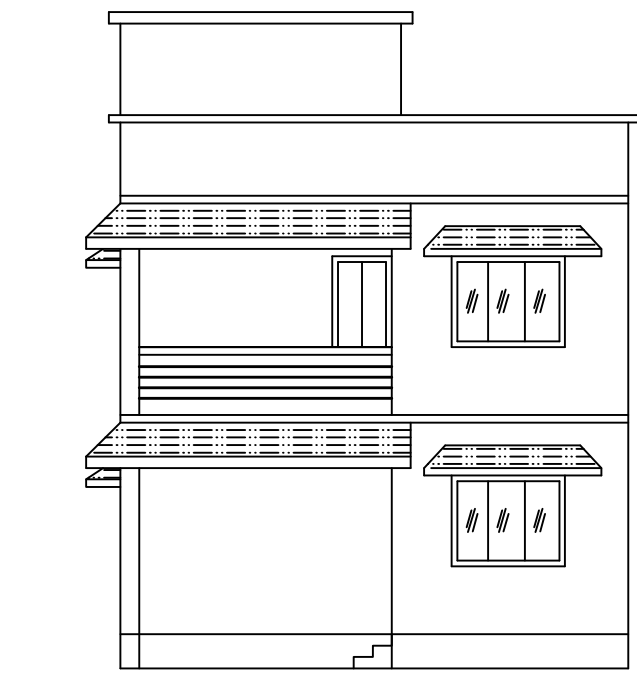

FRONT ELEVATION

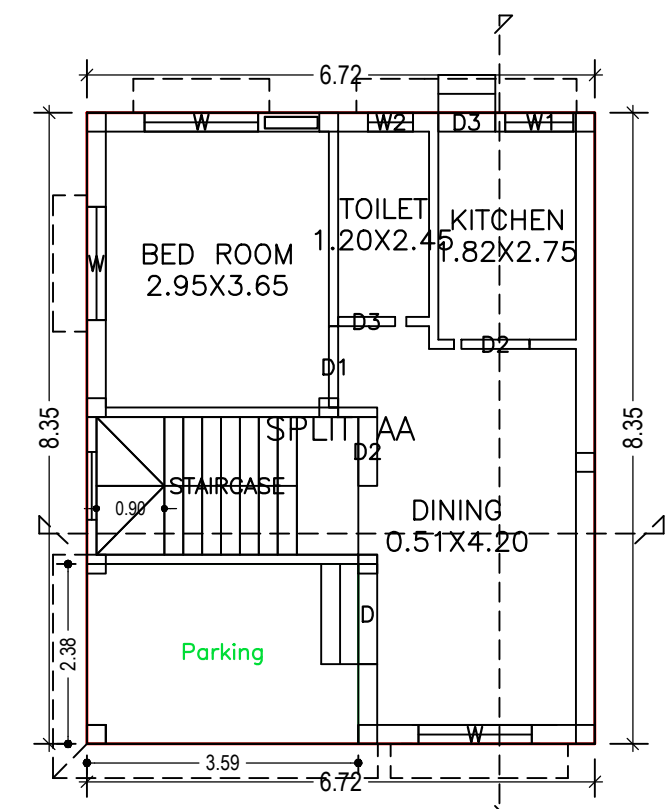

GROUND FLOOR PLAN (Proposed) (SCALE 1:100)

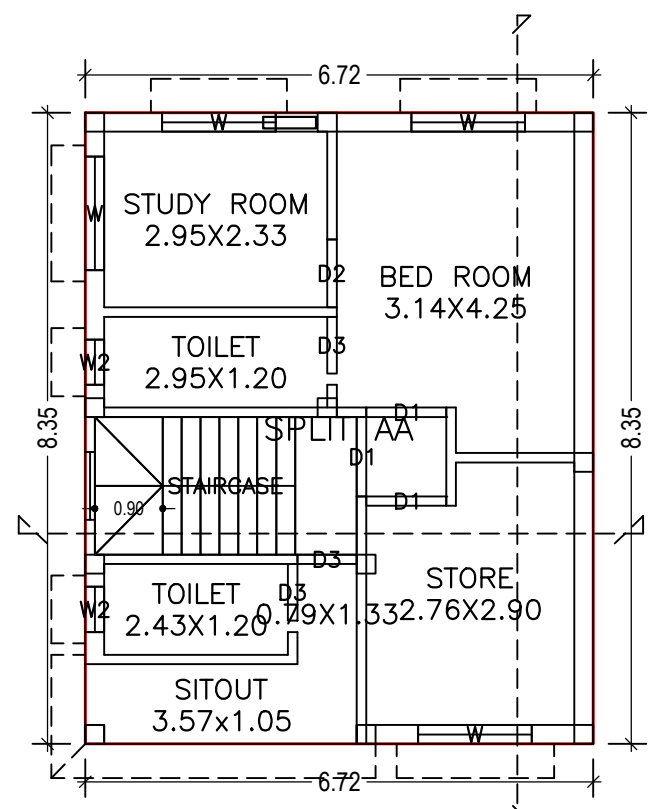

FIRST FLOOR PLAN (Proposed) (SCALE 1:100)

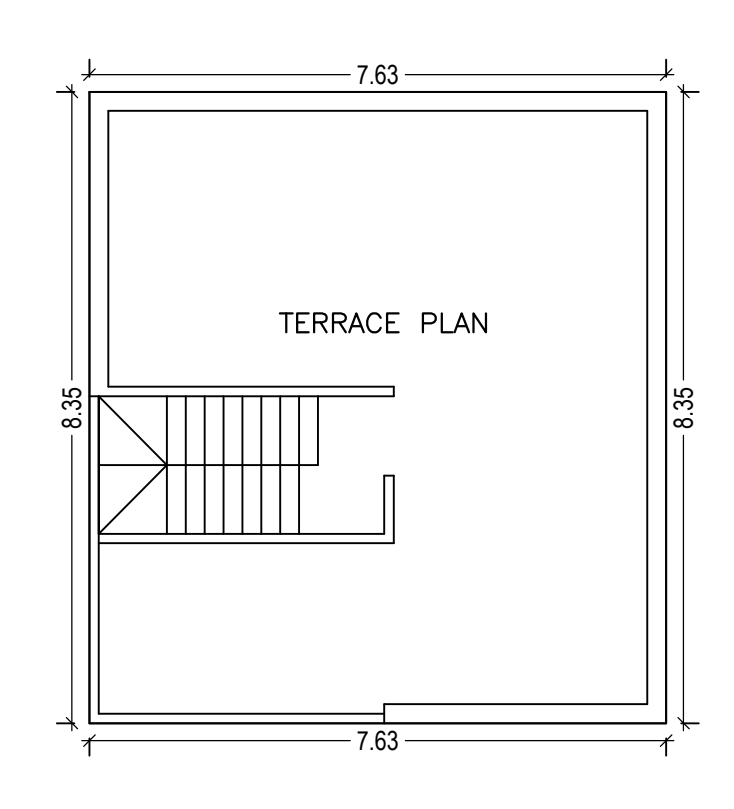

TERRACE FLOOR PLAN (SCALE 1:100)

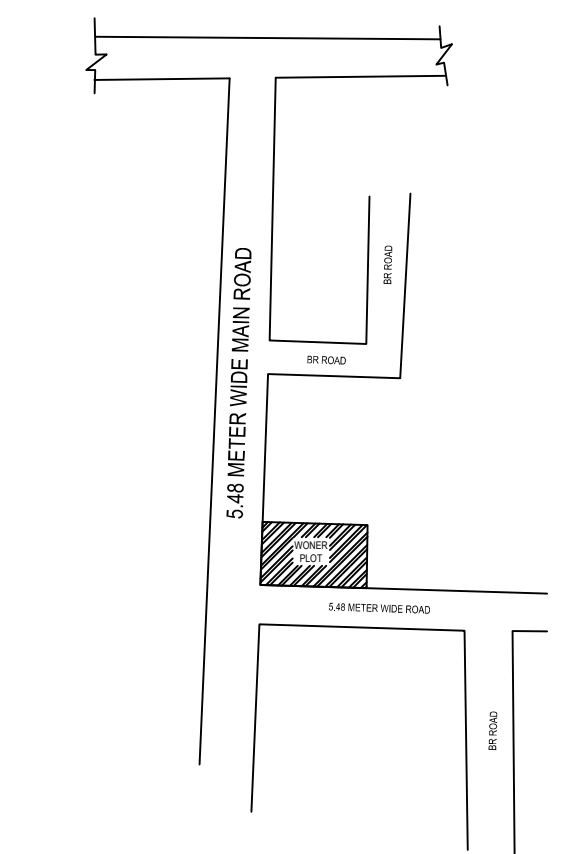

LOCATION PLAN

SCHEDULE OF DOOR:

BUILDING NAME	NAME	LENGTH	HEIGHT	NOS
AA (AA)	D3	0.75	2.10	04
AA (AA)	D3	0.79	2.10	01
AA (AA)	D2	0.90	2.10	02
AA (AA)	D2	0.91	2.10	01
AA (AA)	D1	1.06	2.10	02
AA (AA)	D1	1.08	2.10	01
AA (AA)	D	1.33	2.10	01

SCHEDULE OF WINDOW/VENTILATION:

BUILDING NAME	NAME	LENGTH	HEIGHT	NOS
AA (AA)	W2	0.60	1.20	03
AA (AA)	W1	0.90	1.20	01
AA (AA)	W	1.50	1.20	07

Building :AA (AA)

Floor Name	Total Built Up Area (Sq.mt.)	Proposed FAR Area (Sq.mt.) Res.	Total FAR Area (Sq.mt.)	Total Consumed Additional FAR Area (Sq.mt.)	Tnmt (No.)
Ground Floor	56.11	56.11	56.11	56.11	01
First Floor	56.11	56.11	56.11	56.11	00
Terrace Floor	0.00	0.00	0.00	0.00	00
Total :	112.22	112.22	112.22	112.22	01
Total Number of Same Buildings :	1				
Total :	112.22	112.22	112.22	112.22	01

LTP NAME AND SIGNATURE: PARTHA - PAL, DMC/ENG/0021/2016

STRUCTURAL ENG'S NAME AND SIGNATURE: PARTHA - PAL  
BUILDER NAME AND SIGNATURE: PARTHA - PAL  
DIGITAL SIGNATURE

AREA STATEMENT	VERSION NO.: 1.0.42	SQ.MT.
DHANBAD MUNICIPAL CORPORATION	VERSION DATE: 29/04/2019	
PROJECT DETAIL:		
Region: JHARKHAND URBAN LOCAL BODIES	Plot Use: Residential	
District: DHANBAD	Plot SubUse: Bungalow/ Dwelling / Non Apartment	
Authority: DHANBAD MUNICIPAL CORPORATION	PlotNearbyReligiousStructure: NA	
Inward No: DMC/BP/0331/W23/2019	Plot/SubPlot No: 1857 ( Old ), 2417 ( New )	
Application Type: General Proposal	North: Plot No. - NEW PLOT NO - 2418	
Project Type: Building Permission	South: Road Width - 5.48	
Nature of Development: New	East: Plot No. - PART OF PLOT NO - 2417	
Location of Development Area: Old Area	West: Road Width - 5.48	
AREA DETAILS:		
AREA OF PLOT (Minimum)	(A)	90.53
NET AREA OF PLOT (Gross Plot Area - Deduction from Gross Plot area)	(A-Deductions)	90.53
Deduction for Balance Plot Area (from Gross Plot Area)		
Common Plot		17.70
Total		17.70
BALANCE AREA OF PLOT (Net Plot Area - Recreational/Amenity space)	(A-Deductions)	72.83
PLOT AREA FOR COVERAGE (Net Plot Area)	(A-Deductions)	90.53
Plot Area for FAR (Net Plot Area + Road Widening Area)	(A-Deductions)	90.53
COVERAGE CHECK		
Permissible Coverage area ( 70.00 % )		63.37
Proposed Coverage Area ( 61.98 % )		56.11
Total Prop. Coverage Area ( 61.98 % )		56.11
Balance coverage area ( 8.02 % )		7.26
FAR CHECK		
Perm. FAR Area ( 1.80 )		162.95
Total Perm. FAR area		162.95
Residential FAR		112.22
Proposed FAR Area		112.22
Total Proposed FAR Area		112.22
Consumed FAR (Factor)		1.24
Balance FAR Area		50.73
BUILT UP AREA CHECK		
Total Proposed BuiltUp Area		112.22
ARCHITECT (Regd)	PARTHA - PAL	
ENGINEER (Regd)		
SUPERVISOR (Regd)		
OWNER (Regd)	SMT. POONAM KUMARI SINGH.	
DEVELOPMENT AUTHORITY	LOCAL BODY	

COLOR INDEX	
PLOT BOUNDARY	Black
ABUTTING ROAD	Green
PROPOSED CONSTRUCTION	Red
COMMON PLOT	Yellow
ROAD WIDENING AREA	Blue
EXISTING (To be retained)	Orange
EXISTING (To be demolished)	Light Blue

Buildingwise Floor FAR Details

Floor Name	Building Name		Total	
	Proposed Built Up Area (Sq.mt.)	Proposed FAR Area (Sq.mt.)	Total Proposed Built Up Area (Sq.mt.)	Total FAR Area (Sq.mt.)
Ground Floor	56.11	56.11	56.11	56.11
First Floor	56.11	56.11	56.11	56.11
Terrace Floor	0.00	0.00	0.00	0.00
Total :	112.22	112.22	112.22	112.22

Building USE/SUBUSE Details

Building Name	Building Use	Building SubUse	Building Structure
AA (AA)	Residential	Bungalow/ Dwelling / Non Apartment	Non-Highrise

FAR & Tenement Details (Table 4c-1)

Building	No. of Same Bldg	Total Built Up Area (Sq.mt.)	Proposed FAR Area (Sq.mt.) Res.	Total FAR Area (Sq.mt.)	Total Consumed Additional FAR Area (Sq.mt.)	Tnmt (No.)
AA (AA)	1	112.22	112.22	112.22	112.22	01
Grand Total :	1	112.22	112.22	112.22	112.22	01

UnitBUA Table for Building :AA (AA)

FLOOR	Name	UnitBUA Type	UnitBUA Area	Carpet Area	No. of Rooms	No. of Tenement
GROUND FLOOR PLAN	SPLIT AA	FLAT	112.22	112.01	4	1
FIRST FLOOR PLAN	SPLIT AA	FLAT	0.00	0.00	6	0
Total:	-	-	112.22	112.01	10	1