

Project Title :SMT_POONAM KUMARI SINGH

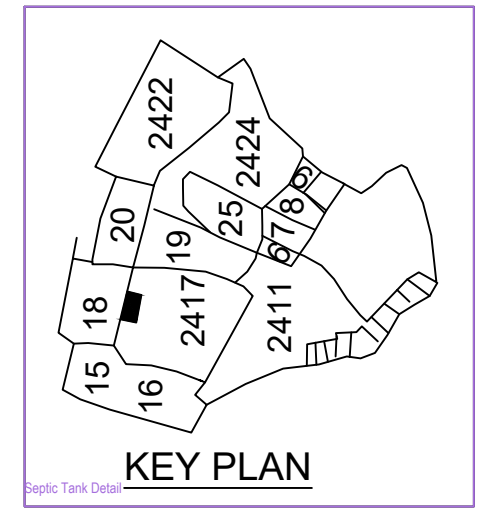
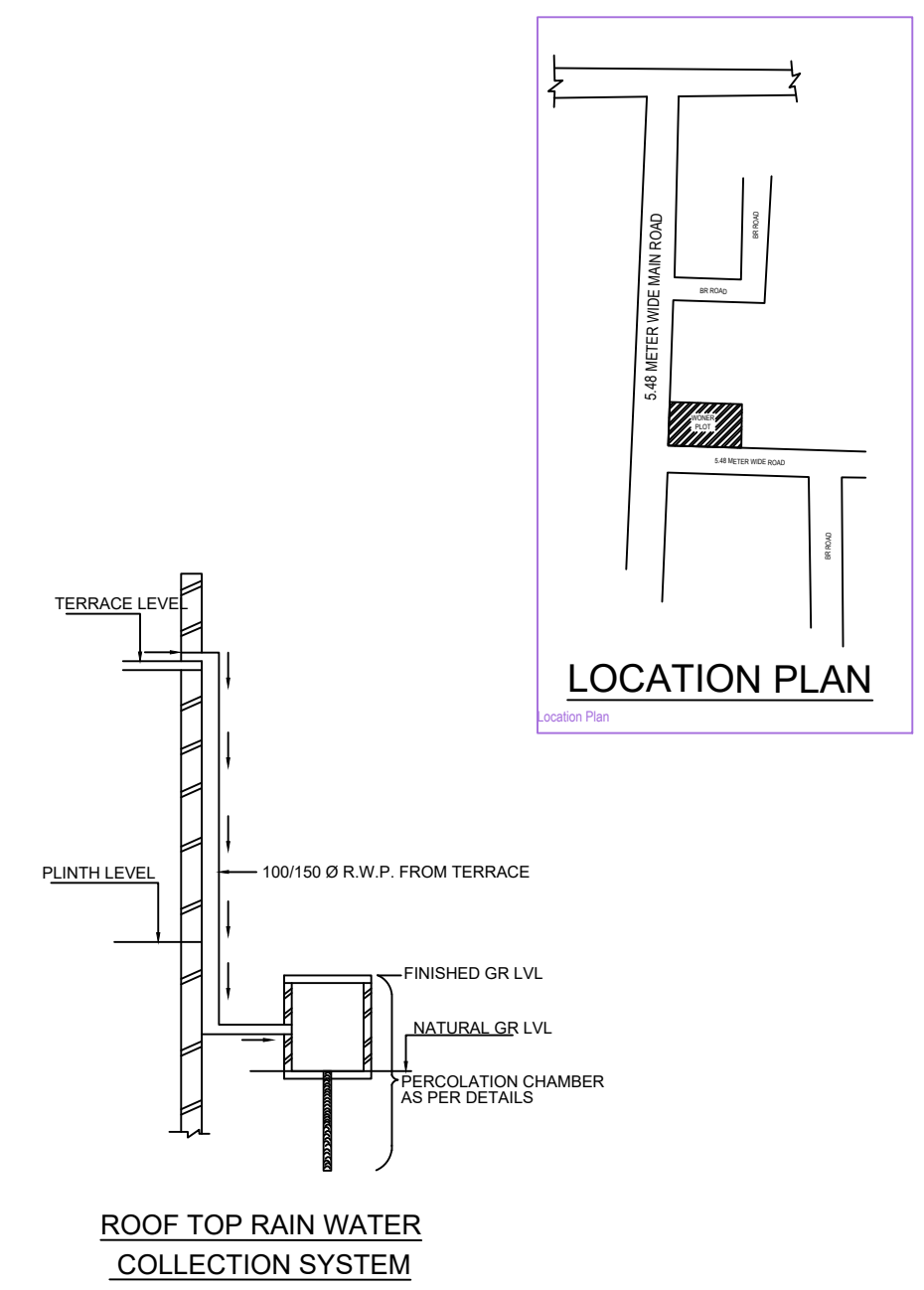
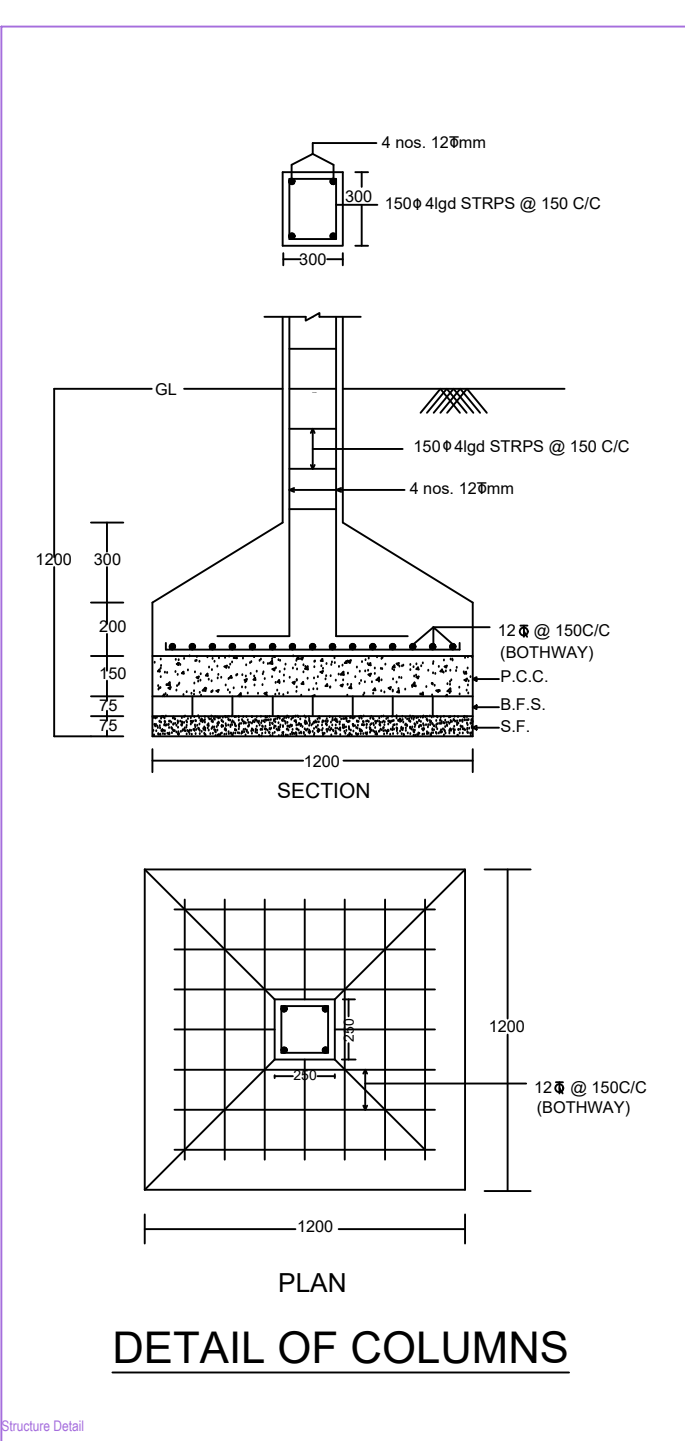
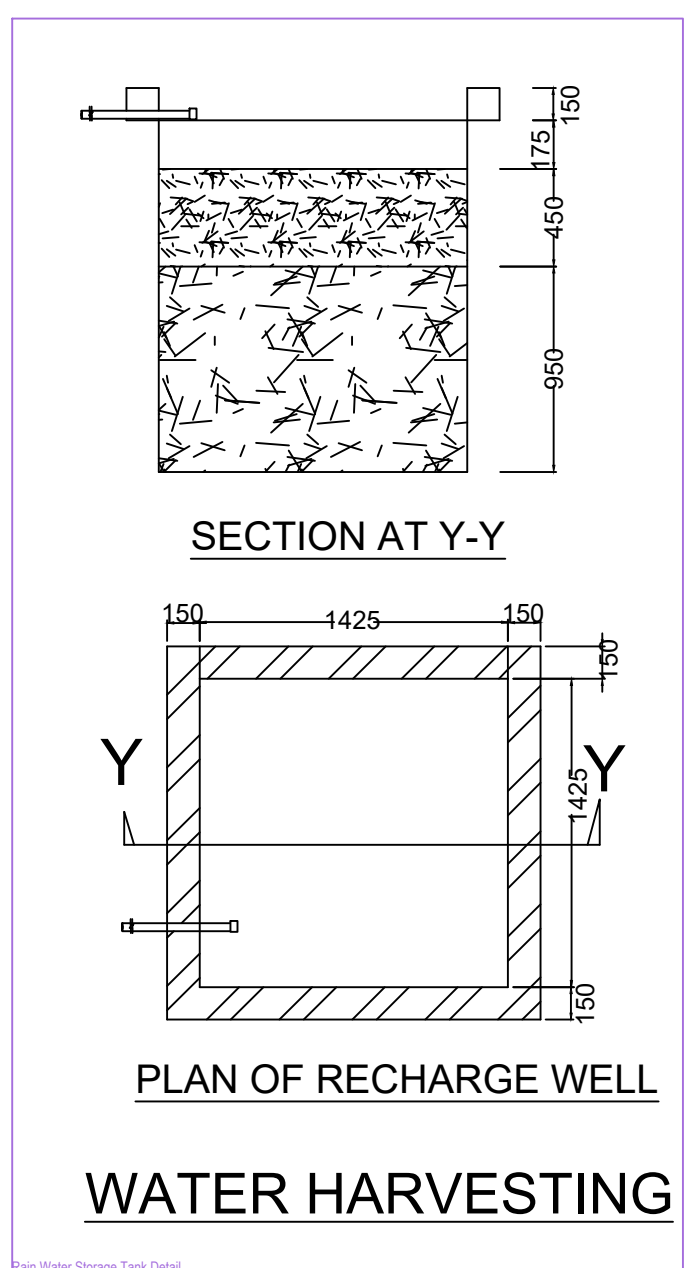
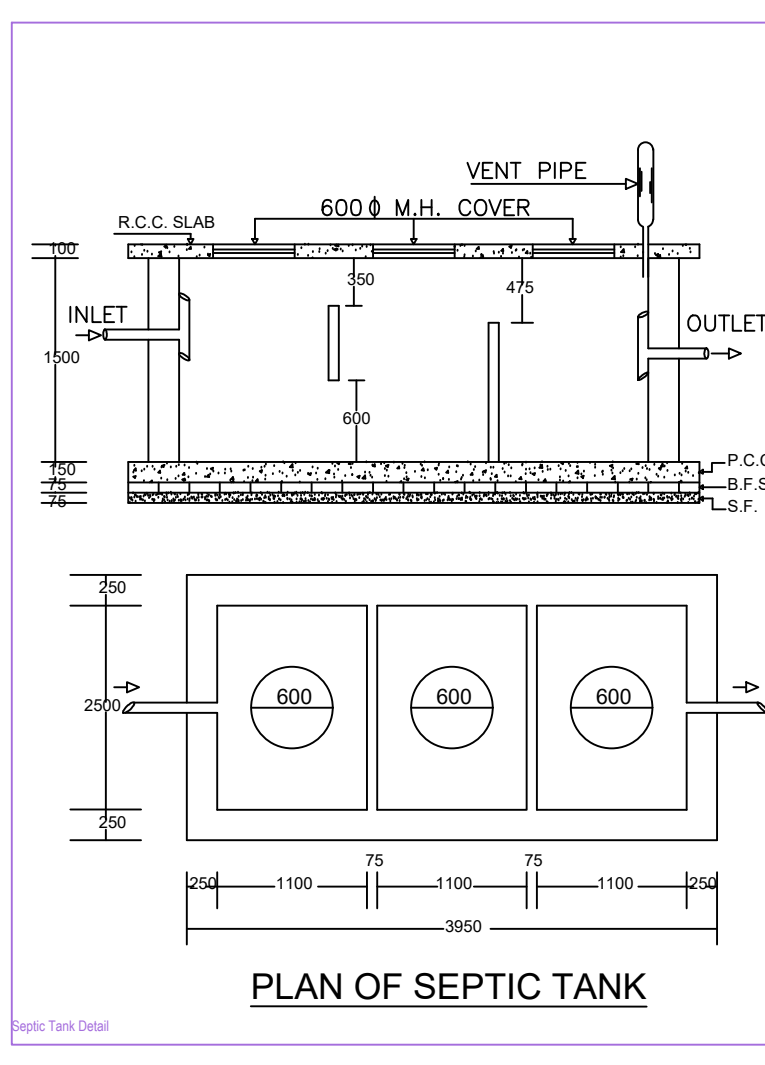
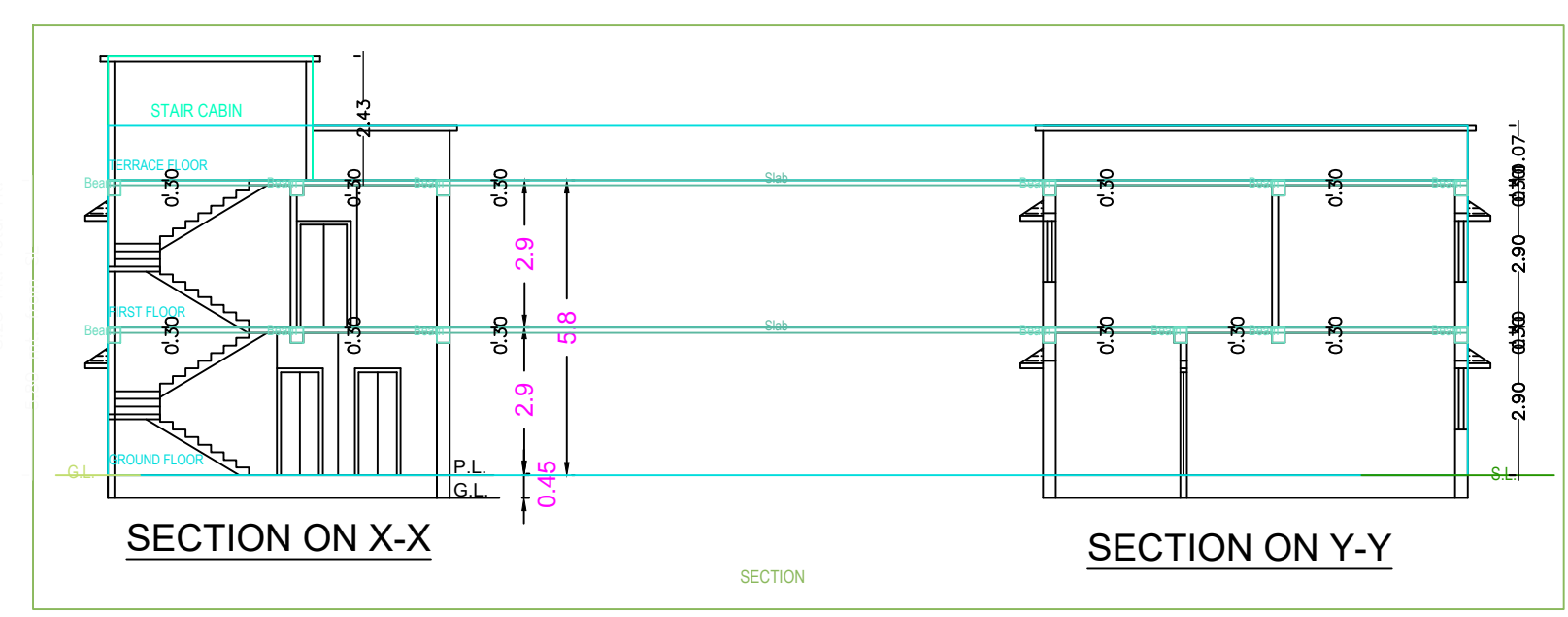
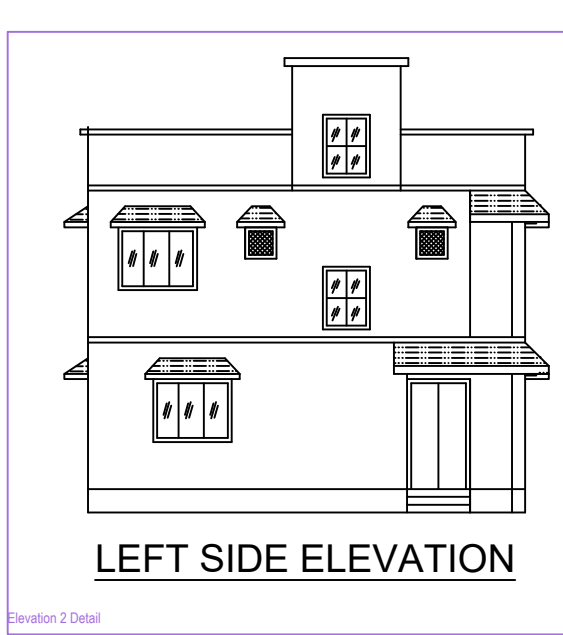
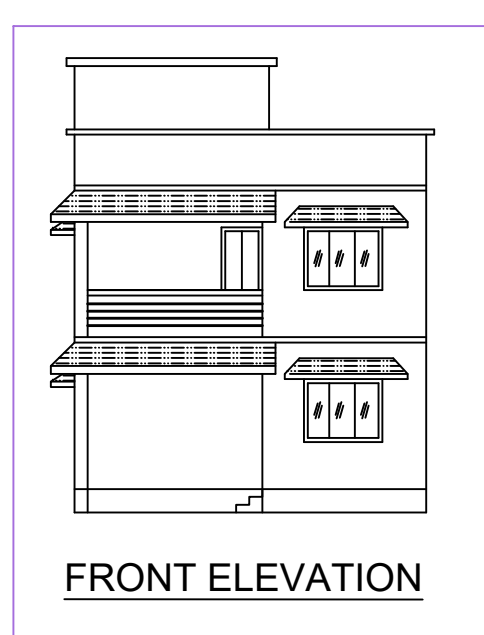

BRIEF SPECIFICATION
 FOUNDATION----- CEMENT CONCRETE (1:1.5:3)
 BRICK WORK IN FOUNDATION & SUPERSTRUCTURE
 FIRST CLASS BRICK WORK IN CEMENT MORTAR (1:6)
 D.P.C-----25 D.P.C. IN CEMENT CONCRETE (1:2:4)
 FLOOR-----25 I.P.S. OVER 75 P.C.C.
 ROOF-----100 THK. R.C.C. ROOF (1:1.5:3)
 LINTEL-----150 THK. R.C.C. LINTEL (1:1.5:3)
 STAIRS-----RISE- 150, TREAD- 250

DETAILS OF AREA

TOTAL AREA (AS PER DEED)	90.57 SQM.
TOTAL AREA (AS PER SITE)	90.52 SQM.
GROUND FLOOR AREA	56.11 SQM.
FIRST FLOOR AREA	56.11 SQM.
TOTAL COVERED AREA	112.22 SQM.
% PLINTH AREA	61.98 %
FAR	1.23

SCHEDULE

D	=	1.200X2.100	W1	=	1.500X1.200
D1	=	1.050X2.100	W2	=	0.900X1.200
D2	=	0.900X2.100	V	=	0.600X0.600

TITLE OF DRAWING
 PLAN OF PROPOSED RESIDENTIAL BUILDING OF SMT. POONAM KUMARI SINGH W/O SRI. VIKASH KUMAR OF VILL.- CHANDORE BANDH, TETULMARI, DHANBAD, UNDER MOUZA - KOLAKUSMA, NO.- 12, KHATA NO.- 30, NEW KHATA NO. 600, PLOT NO.- 1857 NEW PLOT NO.- 2417 IN THE DISTT. OF DHANBAD (JHARKHAND).

SIGNATURE OF OWNER

SIGNATURE OF ENGINEER

SCALE ALL DIMENSION ARE IN METRE

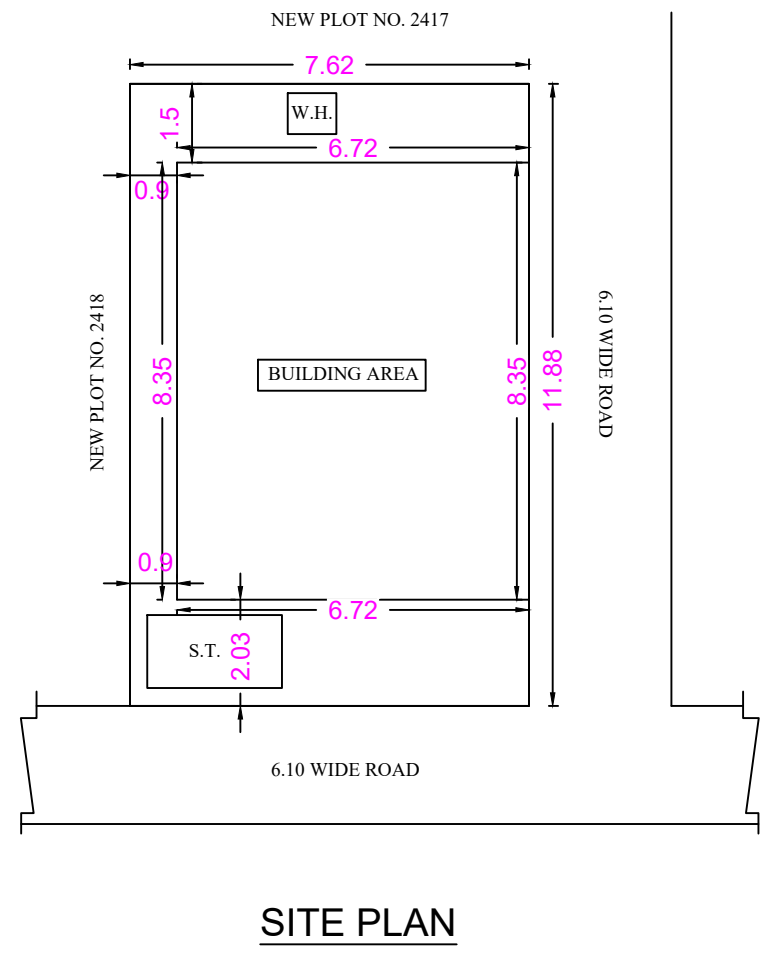
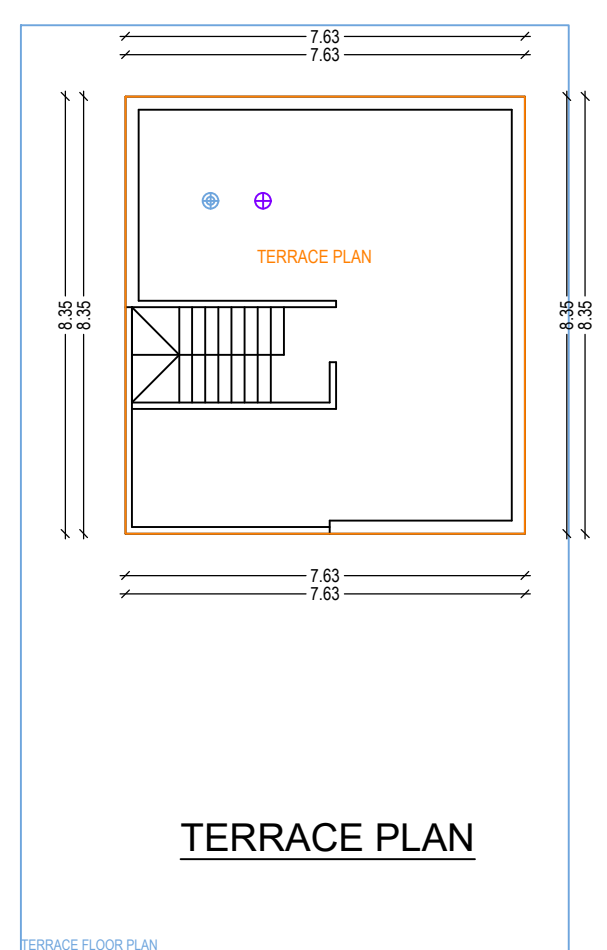
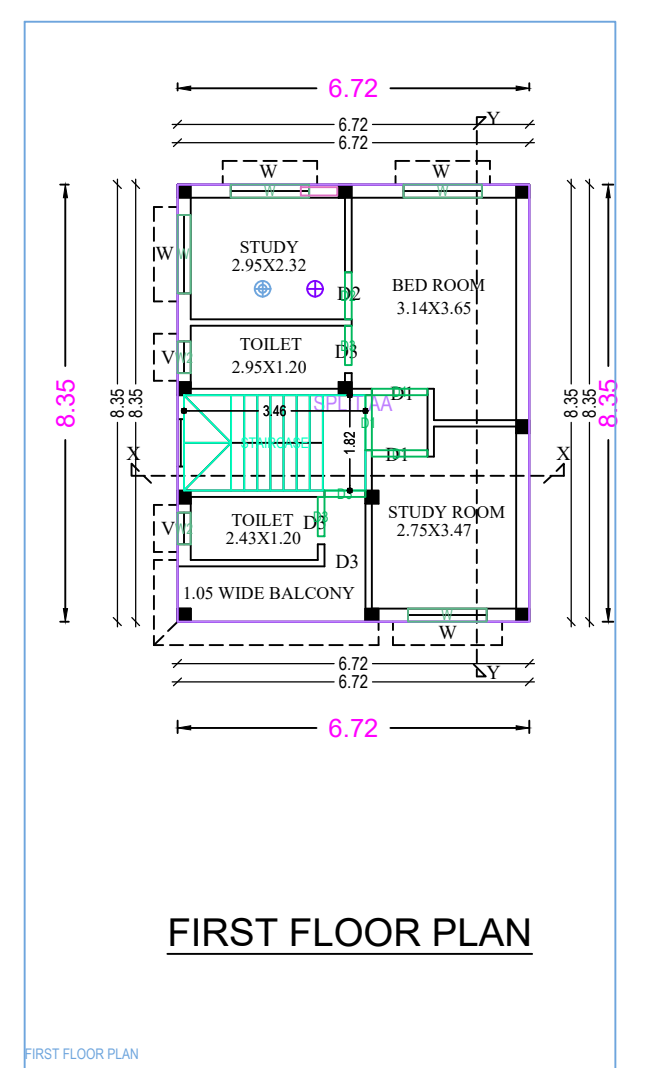
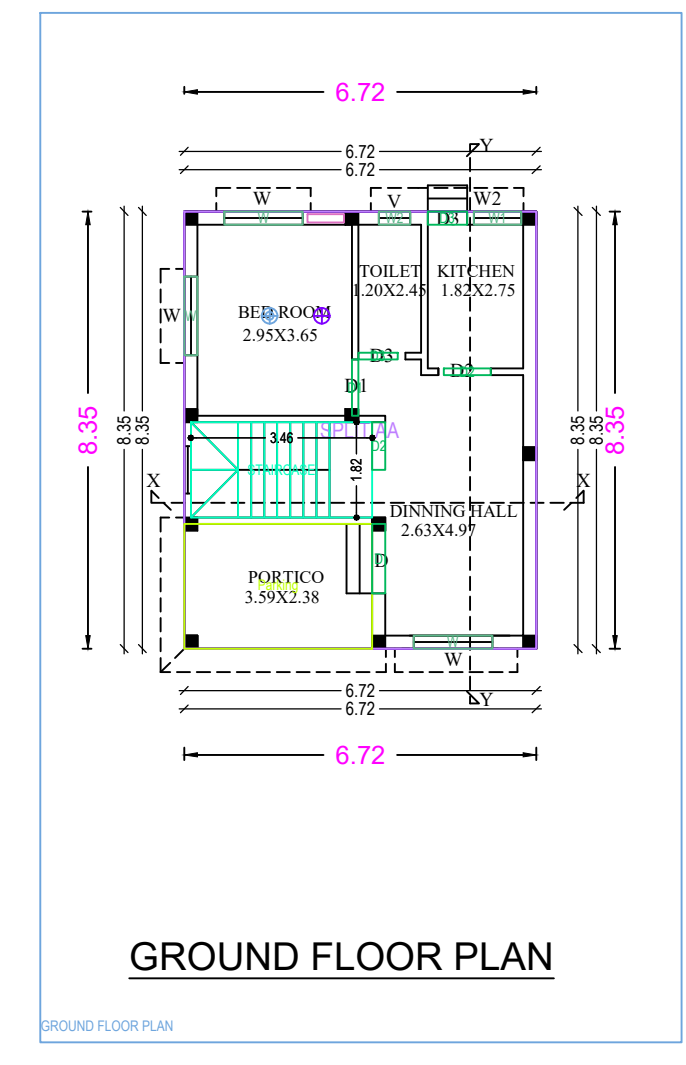
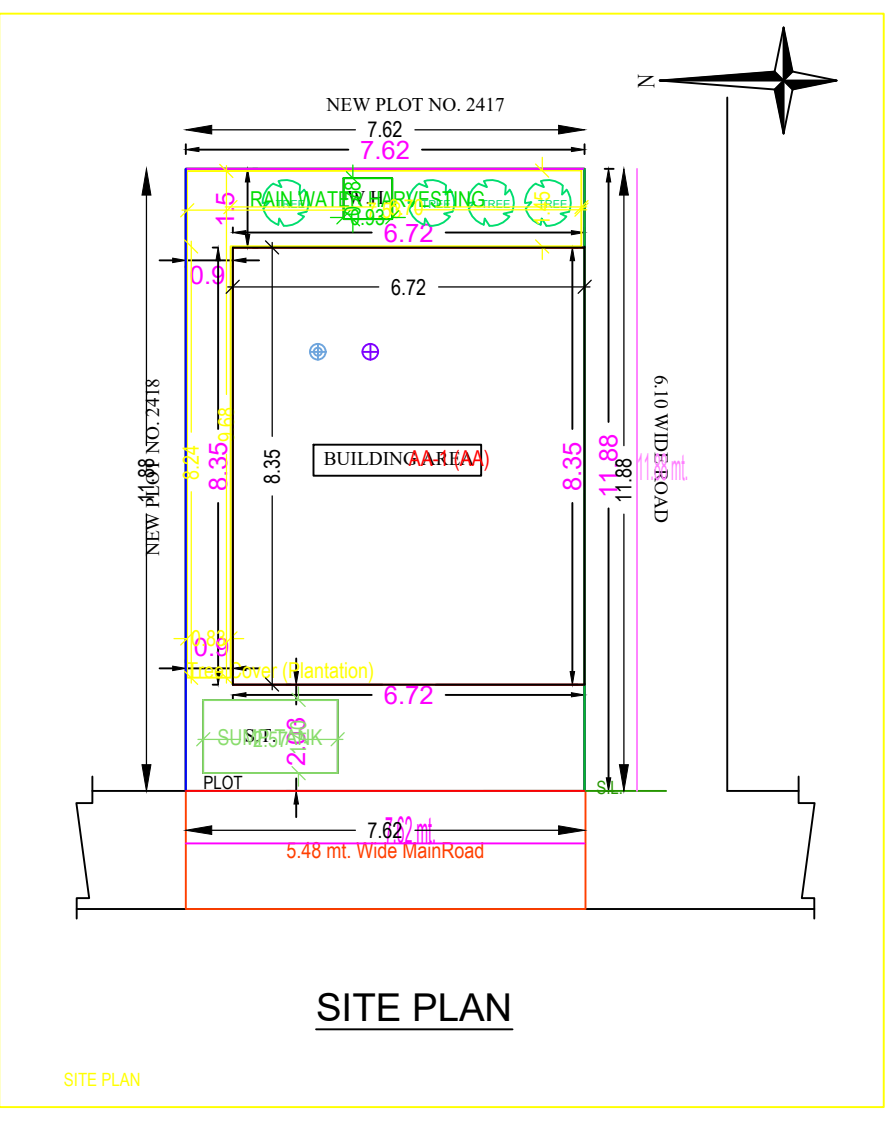

Building -AA (AA)

Floor Name	Total Built Up Area (Sq.Mt.)	Proposed FAR Area (Sq.Mt.)	Total FAR Area (Sq.Mt.)	Tent (No.)
Ground Floor	56.11	56.11	56.11	01
First Floor	56.11	0.00	0.00	00
Roof Top	0.00	0.00	0.00	00
Total	112.22	112.22	112.22	01
Total Number of Same Buildings	1	112.22	112.22	01

SCHEDULE OF JOINERY:

BUILDING NAME	NAME	LENGTH	HEIGHT	NO.
AA (AA)	01	0.75	2.10	04
AA (AA)	02	0.75	1.20	01
AA (AA)	03	0.90	2.10	02
AA (AA)	04	0.90	2.10	02
AA (AA)	05	1.05	2.10	01
AA (AA)	06	1.05	2.10	02
AA (AA)	07	1.05	2.10	01
AA (AA)	08	1.05	2.10	01
AA (AA)	09	1.05	2.10	01
AA (AA)	10	1.05	2.10	01
Total	0	1.35	2.10	13

Unit/BUA Table for Building -AA (AA)

FLOOR	Name	Unit/BUA Type	Unit/BUA Area (Sq.Mt.)	Carpet Area (Sq.Mt.)	No. of Rooms	No. of Tenement
GROUND FLOOR	SPLIT AA	FLAT	112.22	112.01	4	1
Total			112.22	112.01	4	1

AREA STATEMENT -DHANBAD MUNICIPAL CORPORATION

Project No.	Project Name	Project Location	Project Status
AA (AA)	SMT POONAM KUMARI SINGH	CHANDORE BANDH, TETULMARI, DHANBAD	PROPOSED

AREA DETAILS

Item	Area (Sq.Mt.)	Remarks
Total Area (As per Deed)	90.57	
Total Area (As per Site)	90.52	
Ground Floor Area	56.11	
First Floor Area	56.11	
Total Covered Area	112.22	
% Plinth Area	61.98	
FAR	1.23	

PARKING CALCULATION

Category	Area (Sq.Mt.)	Prop. No.	Prop. Area
Open Parking	1.00	1	0.54
Total	1.00	1	0.54

MARGIN DETAIL

Category	Area (Sq.Mt.)	Prop. No.	Prop. Area
Open Parking	1.00	1	0.54
Total	1.00	1	0.54

FAR & Tenement Details (Table 4c-1)

Building	No. of Same Bldg	Total Built Up Area (Sq.Mt.)	Proposed FAR Area (Sq.Mt.)	Total FAR Area (Sq.Mt.)	Tent (No.)
AA (AA)	1	112.22	112.22	112.22	01
Total	1	112.22	112.22	112.22	01