

DETAIL'S OF WATER HARVESTING

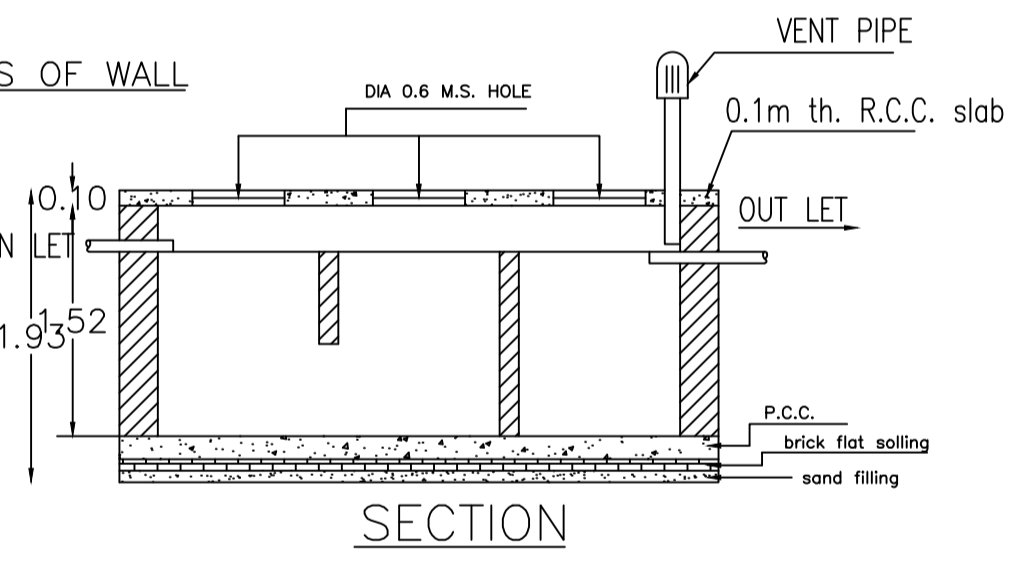
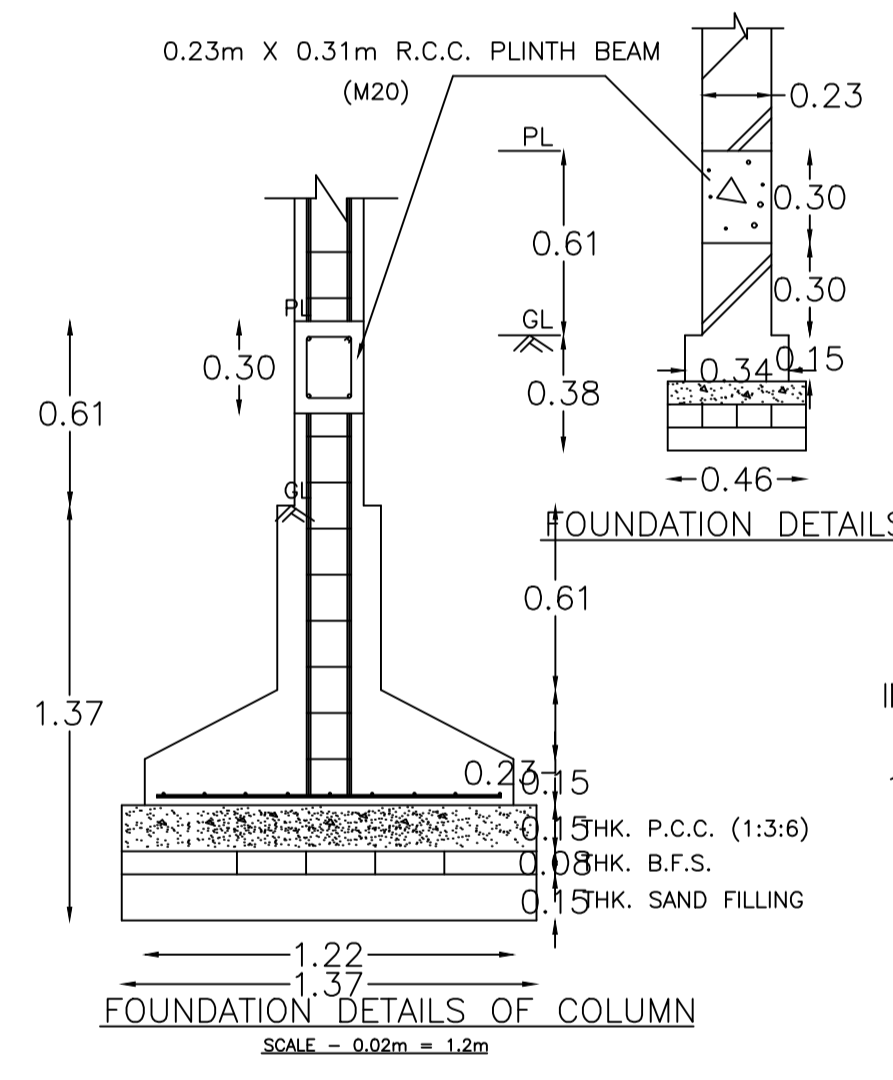

DETAILS OF SEPTIC TANK

SCHEDULE OF DOOR:

BUILDING NAME	NAME	LENGTH	HEIGHT	NOS
A (A)	d	0.90	2.10	12

SCHEDULE OF WINDOW/VENTILATION:

BUILDING NAME	NAME	LENGTH	HEIGHT	NOS
A (A)	w	1.16	1.20	02
A (A)	w	1.80	1.20	22

Proposal Basic Information

Proposal File No.	DMC/BP/0344/W22/2019
Owner Name	GYANSHILA JAISWAL
Khata No	OLD KHATA NO. 74(NEW KHATA NO. 525)
Plot No	OLD PLOT NO. 1663, 1664, 1665( NEW PLOT NO. - 682, 683, 685)
Village Name	Saridhela
Use	Residential
SubUse	Bungalow/ Dwelling / Non Apartment

AREA STATEMENT DHANBAD MUNICIPAL CORPORATION	VERSION NO. : 1.0.46 VERSION DATE: 22/06/2020
PROJECT DETAIL:	
Region: JHARKHAND URBAN LOCAL BODIES	Plot Use: Residential
District: DHANBAD	Plot SubUse: Bungalow/ Dwelling / Non Apartment
Authority: DHANBAD MUNICIPAL CORPORATION	PlotNearby/Religious/Structure: NA
Inward No: DMC/BP/0344/W22/2019	PlotSubPlot No: OLD PLOT NO. 1663, 1664, 1665( NEW PLOT NO. - 682, 683, 685)
Application Type: General Proposal	North: Road Width - 3.66
Project Type: Building Permission	South: Plot No. - PLOT NO. 1662
Nature of Development: New	East: Plot No. - PLOT NO. 1516
Location of Development Area: Old Area	West: Plot No. - PLOT NO. 1666
AREA DETAILS:	
AREA OF PLOT (Minimum)	(A) 179.08 SQ.MT.
NET AREA OF PLOT(Gross Plot Area - Deduction from Gross Plot area)	(A-Deductions) 179.08
Deduction for Balance Plot Area(from Gross Plot Area)	
Total Common Plot	14.62
BALANCE AREA OF PLOT(Net Plot Area - Recreational/Amenity space)	(A-Deductions) 164.47
PLOT AREA FOR COVERAGE(Net Plot Area)	(A-Deductions) 179.08
Plot Area for FAR (Net Plot Area + RoadWidening Area)	(A-Deductions) 179.08
COVERAGE CHECK	
Permissible Coverage area ( 70.00 % )	125.36
Proposed Coverage Area ( 60.06 % )	107.56
Total Prop. Coverage Area ( 60.06 % )	107.56
Balance coverage area ( 9.94 % )	17.80
FAR CHECK	
Perm. FAR Area ( 1.50 )	268.62
Total Perm. FAR area	268.62
Residential FAR	215.11
Proposed FAR Area	215.11
Total Proposed FAR Area	215.11
Consumed FAR (Factor)	1.20
Balance FAR Area	53.51
BUILT UP AREA CHECK	
Total Proposed BuiltUp Area	215.12
ARCHITECT (Regd)	HARSH NANDAN KUMAR
ENGINEER (Regd)	
SUPERVISOR (Regd)	
OWNER (Regd)	GYANSHILA JAISWAL
DEVELOPMENT AUTHORITY LOCAL BODY	

COLOR INDEX	
PLOT BOUNDARY	Black
ABUTTING ROAD	Green
PROPOSED CONSTRUCTION	Red
COMMON PLOT	Blue
ROAD WIDENING AREA	Yellow
EXISTING (To be retained)	Light Blue
EXISTING (To be demolished)	Light Green

Floor Name	Building Name A (A)		Total	
	Proposed Built Up Area (Sq.mt.)	Proposed FAR Area (Sq.mt.)	Total Proposed Built Up Area (Sq.mt.)	Total FAR Area (Sq.mt.)
Ground Floor	107.56	107.56	107.56	107.56
First Floor	107.56	107.56	107.56	107.56
Terrace Floor	0.00	0.00	0.00	0.00
Total :	215.12	215.12	215.12	215.12

Building Name	Building Use	Building SubUse	Building Structure
A (A)	Residential	Residential Bldg/Apartment	Non-Highrise

Building	No. of Same Bldg	Total Built Up Area (Sq.mt.)	Proposed FAR Area (Sq.mt.) Resi.	Total FAR Area (Sq.mt.)	Total Consumed Additional FAR Area (Sq.mt.)	Tnmt (No.)
A (A)	1	215.12	215.12	215.12	215.12	01
Grand Total :	1	215.12	215.12	215.12	215.12	01

UnitBUA Table for Building :A (A)

FLOOR	Name	UnitBUA Type	UnitBUA Area	Carpet Area	No. of Rooms	No. of Tenement
GROUND FLOOR PLAN	SPLIT 1	FLAT	215.11	215.05	7	1
FIRST FLOOR PLAN	SPLIT 1	FLAT	0.00	0.00	7	0
Total:	-	-	215.11	215.05	14	1

Building :A (A)

Floor Name	Total Built Up Area (Sq.mt.)	Proposed FAR Area (Sq.mt.) Resi.	Total FAR Area (Sq.mt.)	Total Consumed Additional FAR Area (Sq.mt.)	Tnmt (No.)
Ground Floor	107.56	107.56	107.56	107.56	01
First Floor	107.56	107.56	107.56	107.56	00
Terrace Floor	0.00	0.00	0.00	0.00	00
Total :	215.12	215.12	215.12	215.12	01
Total Number of Same Buildings :	1				
Total :	215.12	215.12	215.12	215.12	01

LTP NAME AND SIGNATURE HARSH NANDAN KUMAR DMC/ENG/0001/2018	STRUCTURAL ENG'S NAME AND SIGNATURE	BUILDER NAME AND SIGNATURE	DIGITAL SIGNATURE
---	-------------------------------------	----------------------------	-------------------