

Proposal Basic Information

Proposal File No.	DMC/BP/0343/W26/2019
Owner Name	CHANCHAL MUKHERJEE, INDRANI MUKHERJEE
Khata No	108
Plot No	916, 917, 945, 946
Village Name	Hirapur
Use	Residential
SubUse	Bungalow/ Dwelling / Non Apartment

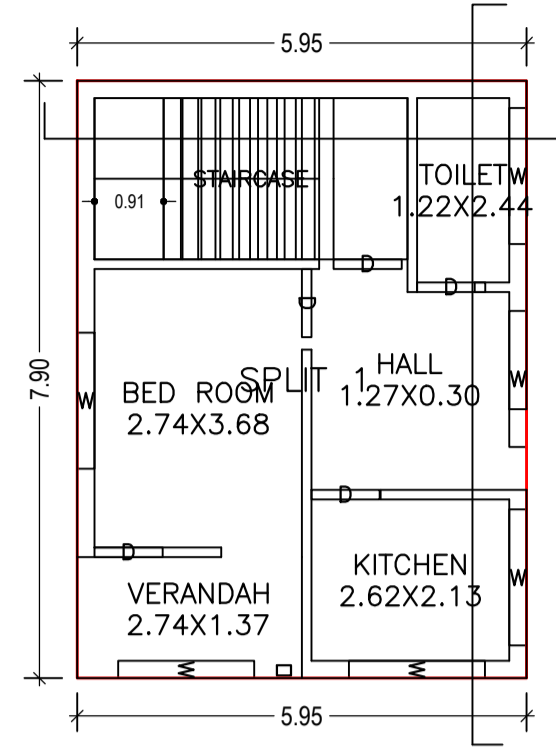

GROUND FLOOR PLAN (Proposed) (SCALE 1:100)

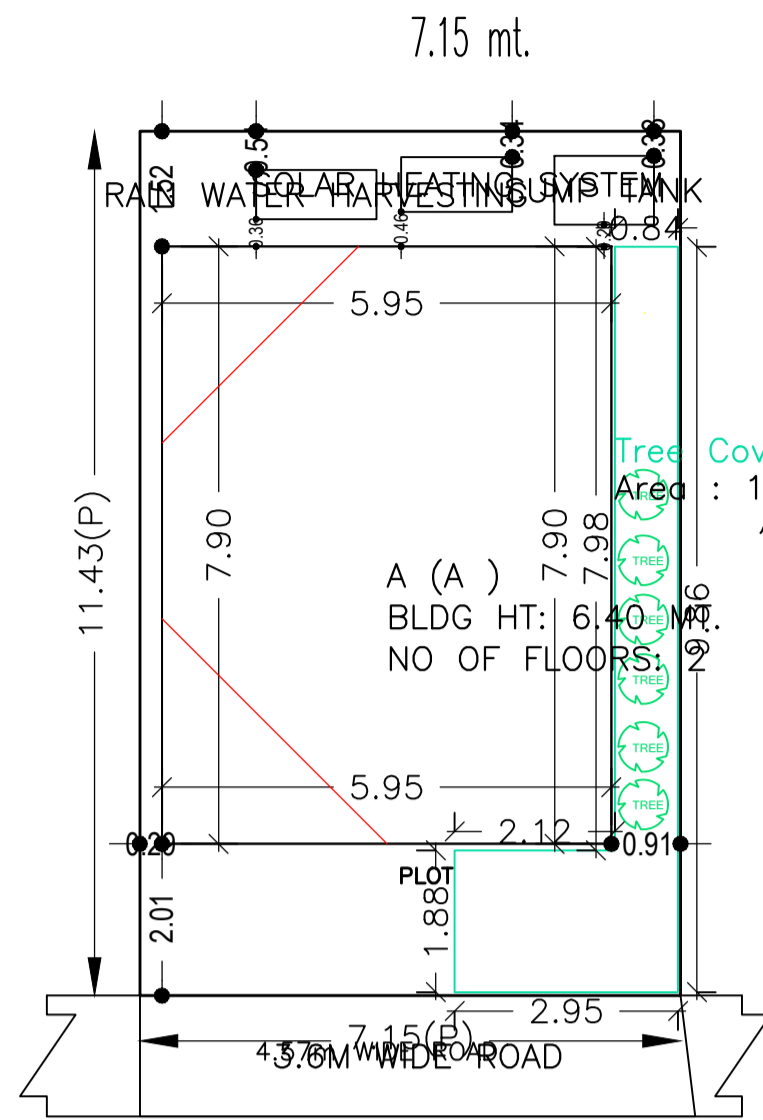
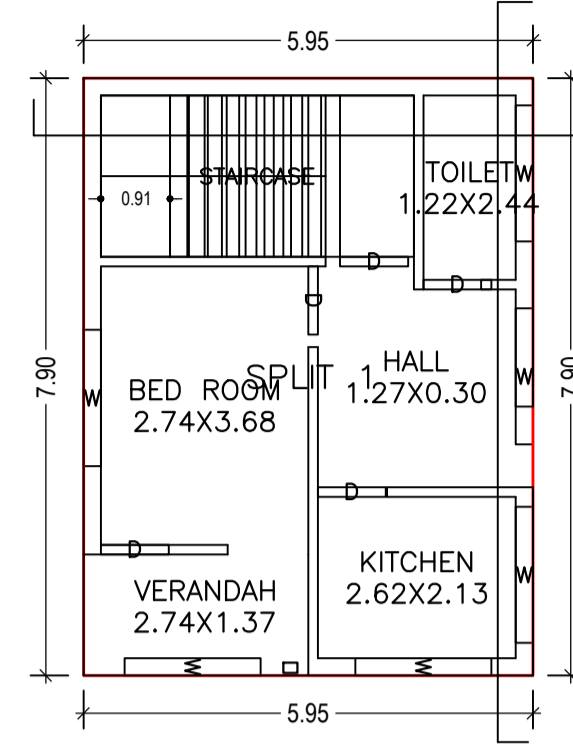

FIRST FLOOR PLAN (Proposed) (SCALE 1:100)

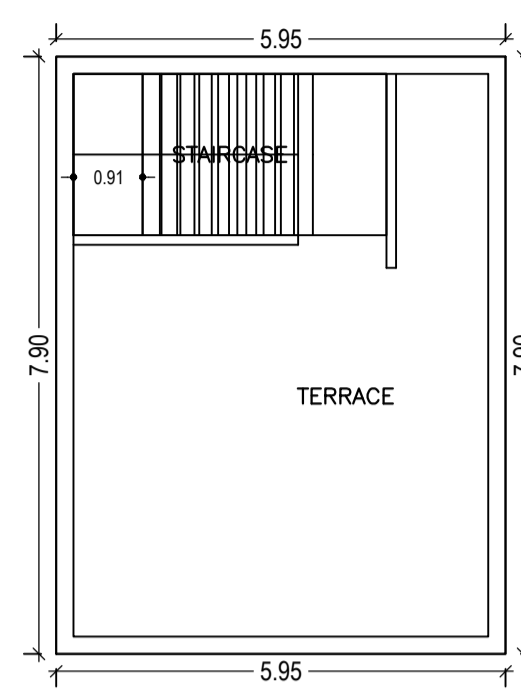

TERRACE FLOOR PLAN (SCALE 1:100)

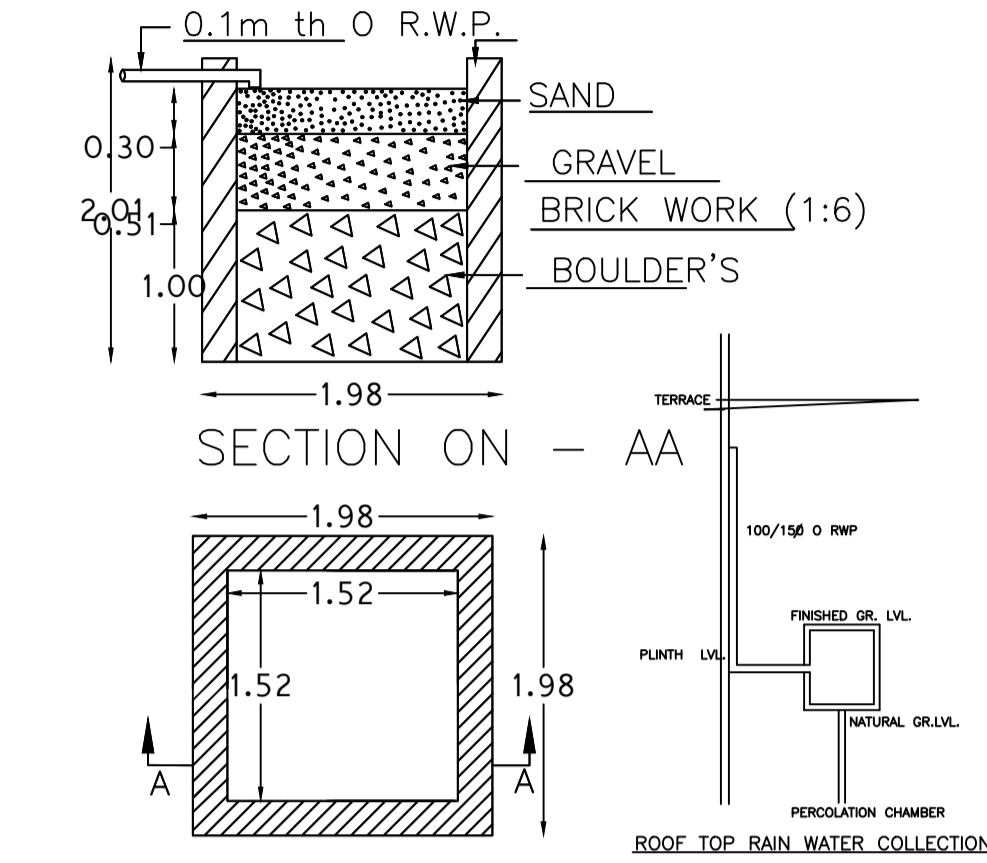

DETAIL'S OF WATER HARVESTING

Building USE/SUBUSE Details

Building Name	Building Use	Building SubUse	Building Structure
A (A)	Residential	Residential Bldg/Apartment	Non-Highrise

Buildingwise Floor FAR Details

Floor Name	Building Name (A (A))		Total	
	Proposed Built Up Area (Sq.mt.)	Proposed FAR Area (Sq.mt.)	Total Proposed Built Up Area (Sq.mt.)	Total FAR Area (Sq.mt.)
Ground Floor	46.97	46.97	46.97	46.97
First Floor	46.97	46.97	46.97	46.97
Terrace Floor	0.00	0.00	0.00	0.00
Total :	93.94	93.94	93.94	93.94

FAR & Tenement Details (Table 4c-1)

Building	No. of Same Bldg	Total Built Up Area (Sq.mt.)	Proposed FAR Area (Sq.mt.)	Total FAR Area (Sq.mt.)	Total Consumed Additional FAR Area (Sq.mt.)	Tnmt (No.)
A (A)	1	93.94	93.94	93.94	93.94	01
Grand Total :	1	93.94	93.94	93.94	93.94	01

COLOR INDEX

PLOT BOUNDARY	Black
ABUTTING ROAD	Red
PROPOSED CONSTRUCTION	Green
COMMON PLOT	Yellow
ROAD WIDENING AREA	Blue
EXISTING (To be retained)	Grey
EXISTING (To be demolished)	White

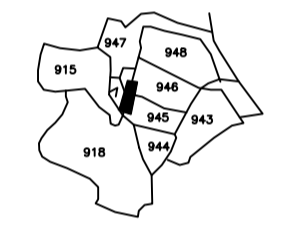

KEY PLAN

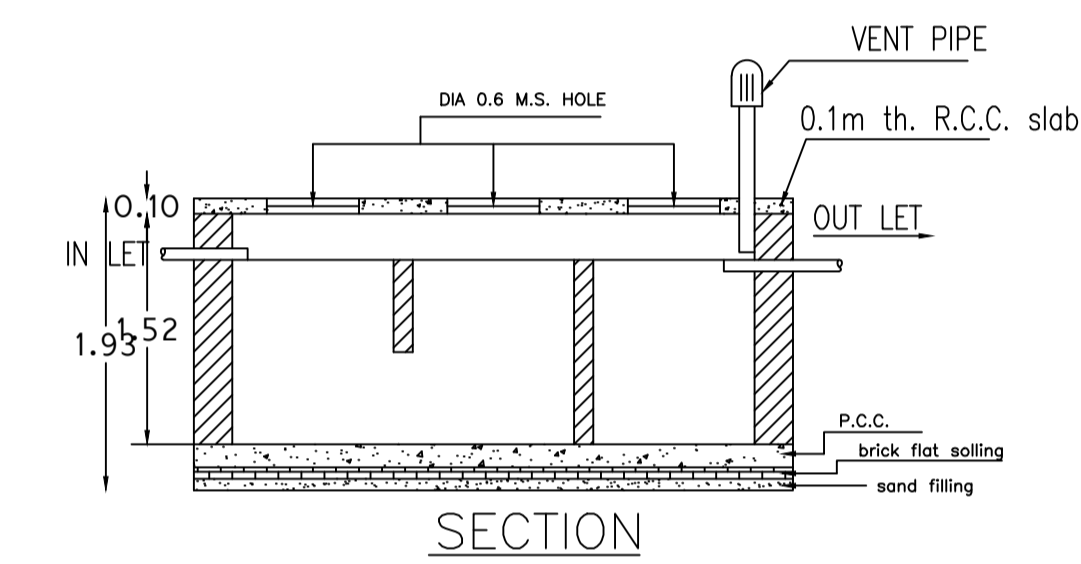

SECTION

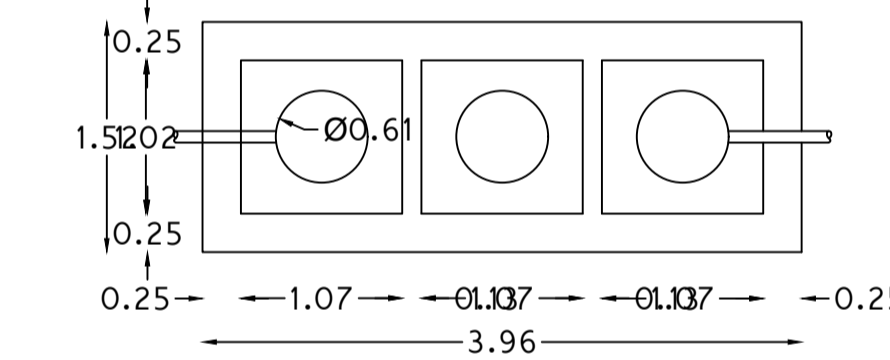

DETAILS OF SEPTIC TANK



FRONT ELEVATION

RIGHT SIDE ELEVATION

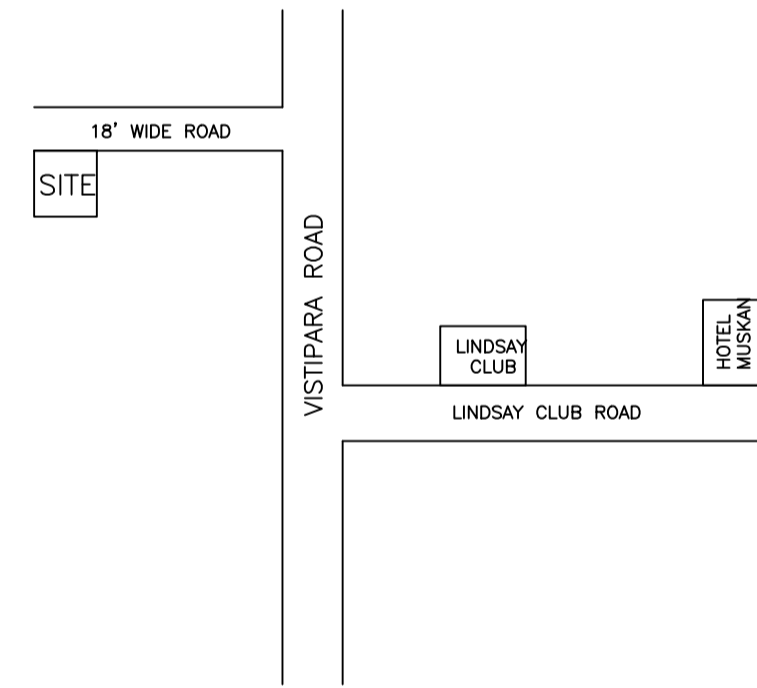

location plan

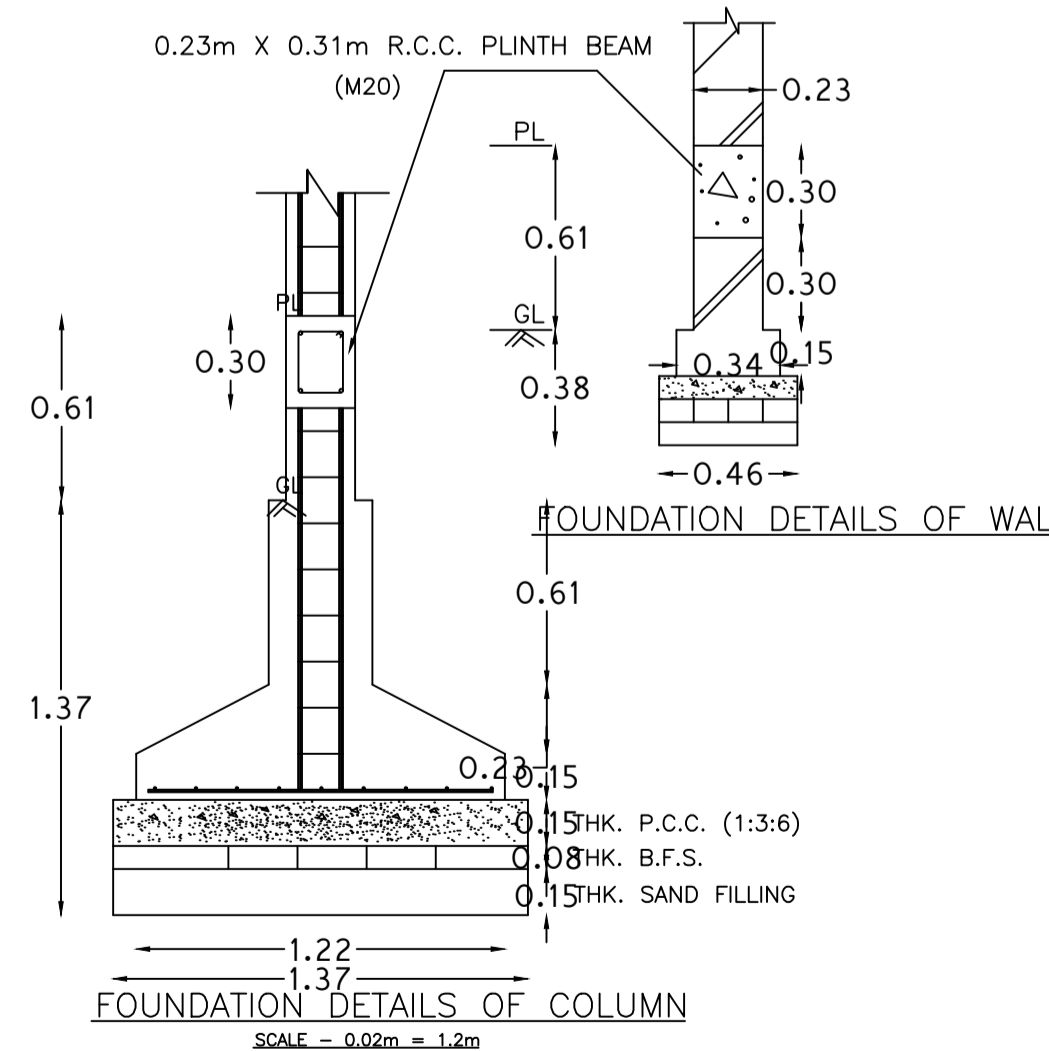

FOUNDATION DETAILS OF COLUMN

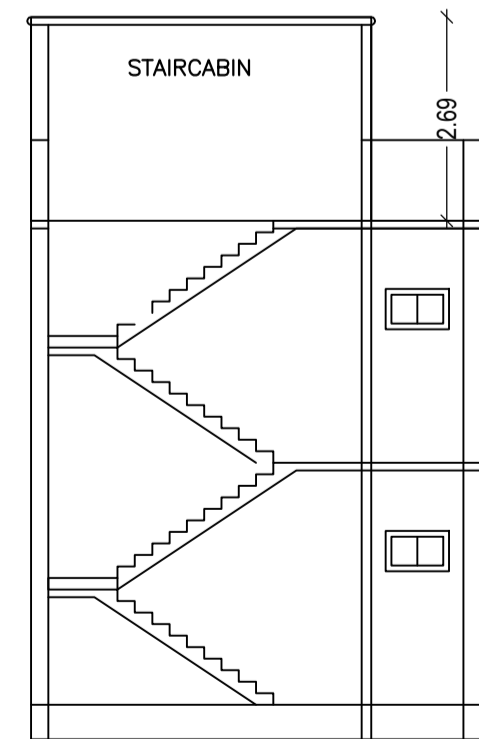

SECTION ON Y-Y

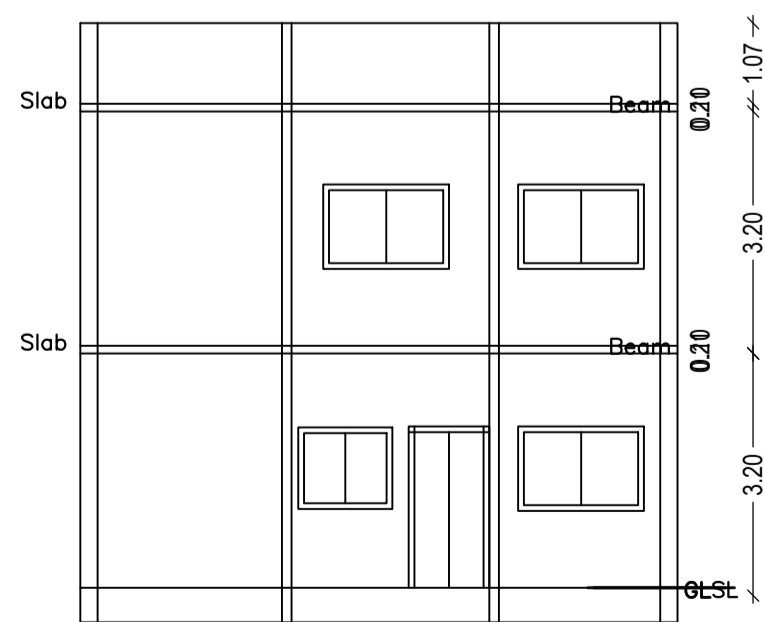

SECTION ON X-X

UnitBUA Table for Building :A (A)

FLOOR	Name	UnitBUA Type	UnitBUA Area	Carpet Area	No. of Rooms	No. of Tenement
GROUND FLOOR PLAN	SPLIT 1	FLAT	93.95	93.89	5	1
FIRST FLOOR PLAN	SPLIT 1	FLAT	0.00	0.00	5	0
Total:	-	-	93.95	93.89	10	1

Building :A (A)

Floor Name	Total Built Up Area (Sq.mt.)	Proposed FAR Area (Sq.mt.)	Total FAR Area (Sq.mt.)	Total Consumed Additional FAR Area (Sq.mt.)	Tnmt (No.)
Ground Floor	46.97	46.97	46.97	46.97	01
First Floor	46.97	46.97	46.97	46.97	00
Terrace Floor	0.00	0.00	0.00	0.00	00
Total :	93.94	93.94	93.94	93.94	01

SCHEDULE OF DOOR:

BUILDING NAME	NAME	LENGTH	HEIGHT	NOS
A (A)	D	0.90	2.10	10

SCHEDULE OF WINDOW/VENTILATION:

BUILDING NAME	NAME	LENGTH	HEIGHT	NOS
A (A)	W	1.80	1.20	12

AREA STATEMENT	VERSION NO. : 1.0.43
DHANBAD MUNICIPAL CORPORATION	VERSION DATE: 29/04/2019
PROJECT DETAIL:	
Region: JHARKHAND URBAN LOCAL BODIES	Plot Use: Residential
District: DHANBAD	Plot SubUse: Bungalow/ Dwelling / Non Apartment
Authority: DHANBAD MUNICIPAL CORPORATION	PlotNearbyReligiousStructure: NA
Inward No: DMC/BP/0343/W26/2019	Plot/SubPlot No: 916, 917, 945, 946
Application Type: General Proposal	North: Plot No. - D.P. MUKHERJEE
Project Type: Building Permission	South: Road Width - 4.57 M
Nature of Development: New	East: Plot No. - HOUSE OF LATE PHANI BHUSHAN
Location of Development Area: Old Area	West: Plot No. - D.P. MUKHERJEE
AREA DETAILS:	SQ.MT.
AREA OF PLOT (Minimum)	(A)
NET AREA OF PLOT(Gross Plot Area - Deduction from Gross Plot area)	(A-Deductions)
Deduction for Balance Plot Area(from Gross Plot Area)	
Common Plot	12.22
Total	12.22
BALANCE AREA OF PLOT(Net Plot Area - Recreational/Amenity space)	(A-Deductions)
Plot Area FOR COVERAGE(Net Plot Area)	(A-Deductions)
Plot Area for FAR (Net Plot Area + RoadWidening Area)	(A-Deductions)
COVERAGRE CHECK	
Permissible Coverage area (70.00 %)	57.24
Proposed Coverage Area (57.44 %)	46.97
Total Prop. Coverage Area (57.44 %)	46.97
Balance coverage area (12.56 %)	10.27
FAR CHECK	
Perm. FAR Area (1.50)	122.65
Total Perm. FAR area	122.65
Residential FAR	93.95
Proposed FAR Area	93.95
Total Proposed FAR Area	93.95
Consumed FAR (Factor)	1.15
Balance FAR Area	28.70
BUILT UP AREA CHECK	
Total Proposed BuiltUp Area	93.94
ARCHITECT (Regd)	HARSH NANDAN KUMAR
ENGINEER (Regd)	
SUPERVISOR (Regd)	
OWNER (Regd)	CHANCHAL MUKHERJEE, INDRANI MUKHERJEE
DEVELOPMENT AUTHORITY	LOCAL BODY

LTP NAME AND SIGNATURE	STRUCTURAL ENG'S NAME AND SIGNATURE	BUILDER NAME AND SIGNATURE	DIGITAL SIGNATURE
HARSH NANDAN KUMAR DMC/ENG/0001/2018			