

Proposal Basic Information

Proposal File No	DMC/BP/0309/W26/2019
Owner Name	RUPA SINGH
Khata No	06
Plot No	198/1170
Village Name	Bhuda
Use	Residential
SubUse	Bungalow/ Dwelling / Non Apartment

COLOR INDEX

PLOT BOUNDARY	Black
ABUTTING ROAD	Red
PROPOSED CONSTRUCTION	Green
COMMON PLOT	Yellow
ROAD WIDENING AREA	Orange
EXISTING (To be retained)	Blue
EXISTING (To be demolished)	Light Blue

Building USE/SUBUSE Details

Building Name	Building Use	Building SubUse	Building Structure
A (A)	Residential	Residential Bldg/Apartment	Non-Highrise

FAR & Tenement Details (Table 4c-1)

Building	No. of Same Bldg	Total Built Up Area (Sq.mt.)	Deductions (Area in Sq.mt.)	Proposed FAR Area (Sq.mt.)	Add Area In FAR (Sq.mt.)	Total FAR Area (Sq.mt.)	Total Consumed Additional FAR Area (Sq.mt.)	Tnmt (No.)
A (A)	1	345.68	104.35	230.46	10.87	241.33	241.33	02
Grand Total :	1	345.68	104.35	230.46	10.87	241.33	241.33	02

Buildingwise Floor FAR Details

Floor Name	Building Name A (A)		Total	
	Proposed Built Up Area (Sq.mt.)	Proposed FAR Area (Sq.mt.)	Total Proposed Built Up Area (Sq.mt.)	Total FAR Area (Sq.mt.)
Ground Floor	115.22	10.87	115.22	10.87
First Floor	115.23	115.23	115.23	115.23
Second Floor	115.23	115.23	115.23	115.23
Terrace Floor	0.00	0.00	0.00	0.00
Total :	345.68	241.33	345.68	241.33

AREA STATEMENT	VERSION NO.:	1.0.42
DHANBAD MUNICIPAL CORPORATION	VERSION DATE:	29/04/2019

PROJECT DETAIL:	Plot Use:	Residential
Region: JHARKHAND URBAN LOCAL BODIES	Plot SubUse:	Bungalow/ Dwelling / Non Apartment
District: DHANBAD	PlotNearbyReligiousStructure:	NA
Authority: DHANBAD MUNICIPAL CORPORATION	Plot/SubPlot No:	198/1170
Inward No: DMC/BP/0309/W26/2019	North:	Road Width - 3.66
Application Type: General Proposal	South:	Plot No. - PART OF SAME PLOT
Project Type: Building Permission	East:	Plot No. - SAME PLOT
Nature of Development: New	West:	Road Width - 4.57
Location of Development Area: Old Area		

AREA DETAILS:		SQ.MT.
AREA OF PLOT (Minimum)	(A)	187.59
NET AREA OF PLOT(Gross Plot Area - Deduction from Gross Plot area)	(A-Deductions)	187.59
Deduction for Balance Plot Area(from Gross Plot Area)		
Common Plot		16.85
Total		16.85
BALANCE AREA OF PLOT(Net Plot Area - Recreational/Amenity space)	(A-Deductions)	170.74
PLOT AREA FOR COVERAGE(Net Plot Area)	(A-Deductions)	187.59
Plot Area for FAR (Net Plot Area + RoadWidening Area)	(A-Deductions)	187.59

COVERAGE CHECK		
Permissible Coverage area ( 70.00 % )		131.31
Proposed Coverage Area ( 61.43 % )		115.23
Total Prop. Coverage Area ( 61.43 % )		115.23
Balance coverage area ( 8.57 % )		16.08
FAR CHECK		
Perm. FAR Area ( 1.50 )		281.39
Total Perm. FAR area		281.39
Residential FAR		230.45
Proposed FAR Area		241.32
Total Proposed FAR Area		241.32
Consumed FAR (Factor)		1.29
Balance FAR Area		40.07
BUILT UP AREA CHECK		
Total Proposed BuiltUp Area		345.68
ARCHITECT (Regd)	SUSHIL KUMAR	
ENGINEER (Regd)		
SUPERVISOR (Regd)		
OWNER (Regd)	RUPA SINGH	
DEVELOPMENT AUTHORITY		LOCAL BODY

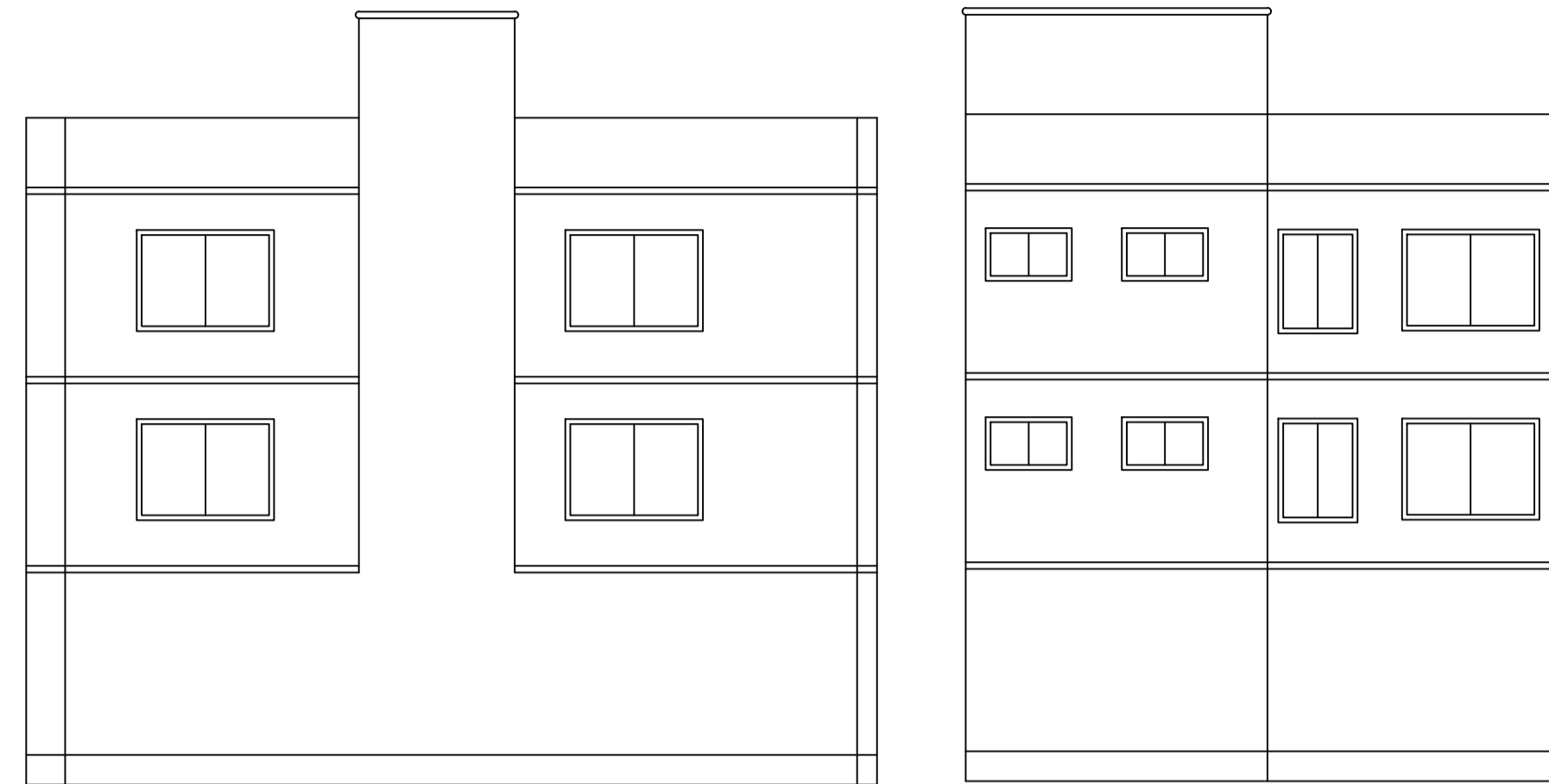
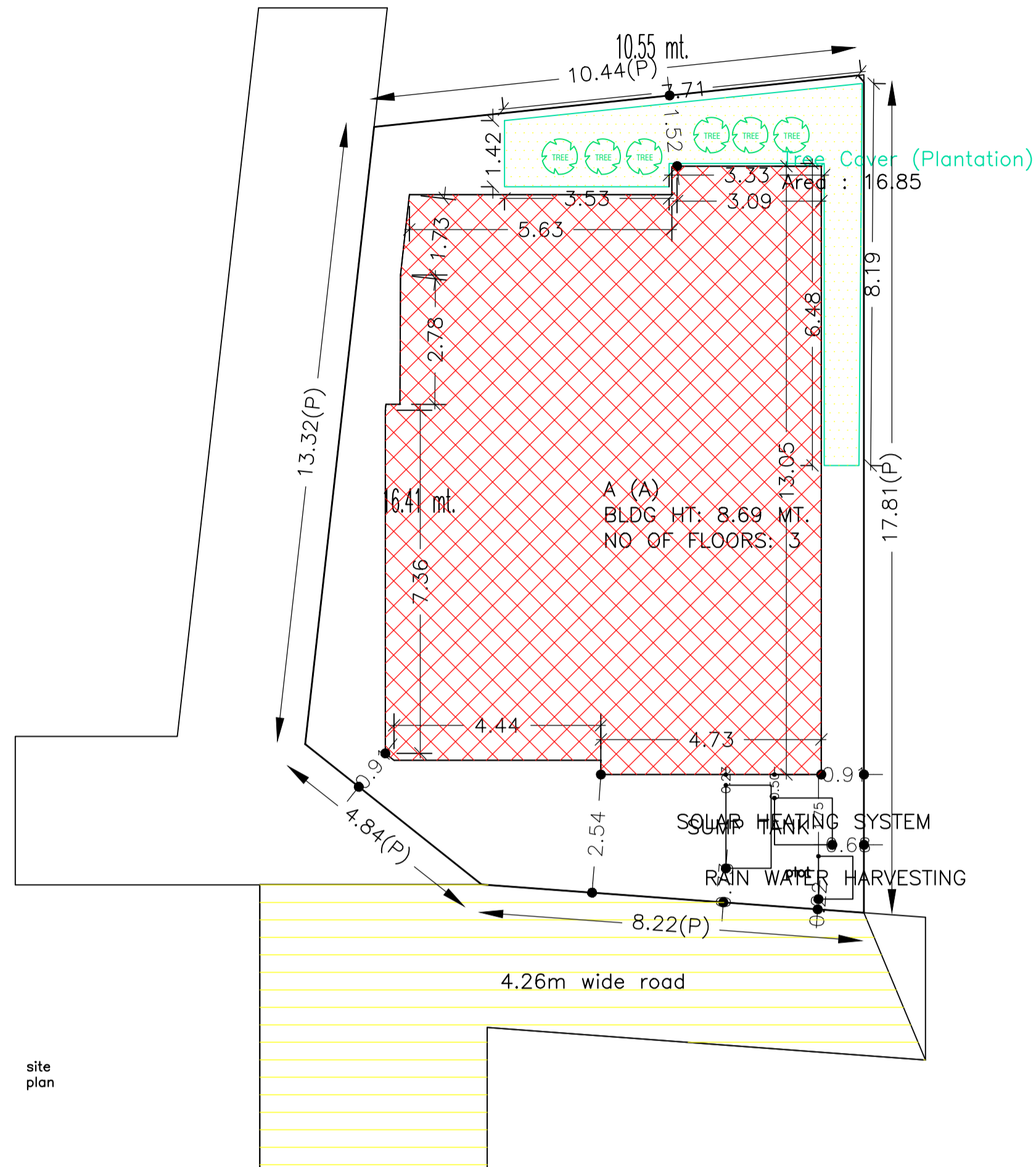

FRONT ELEVATION

RIGHT SIDE ELEVATION

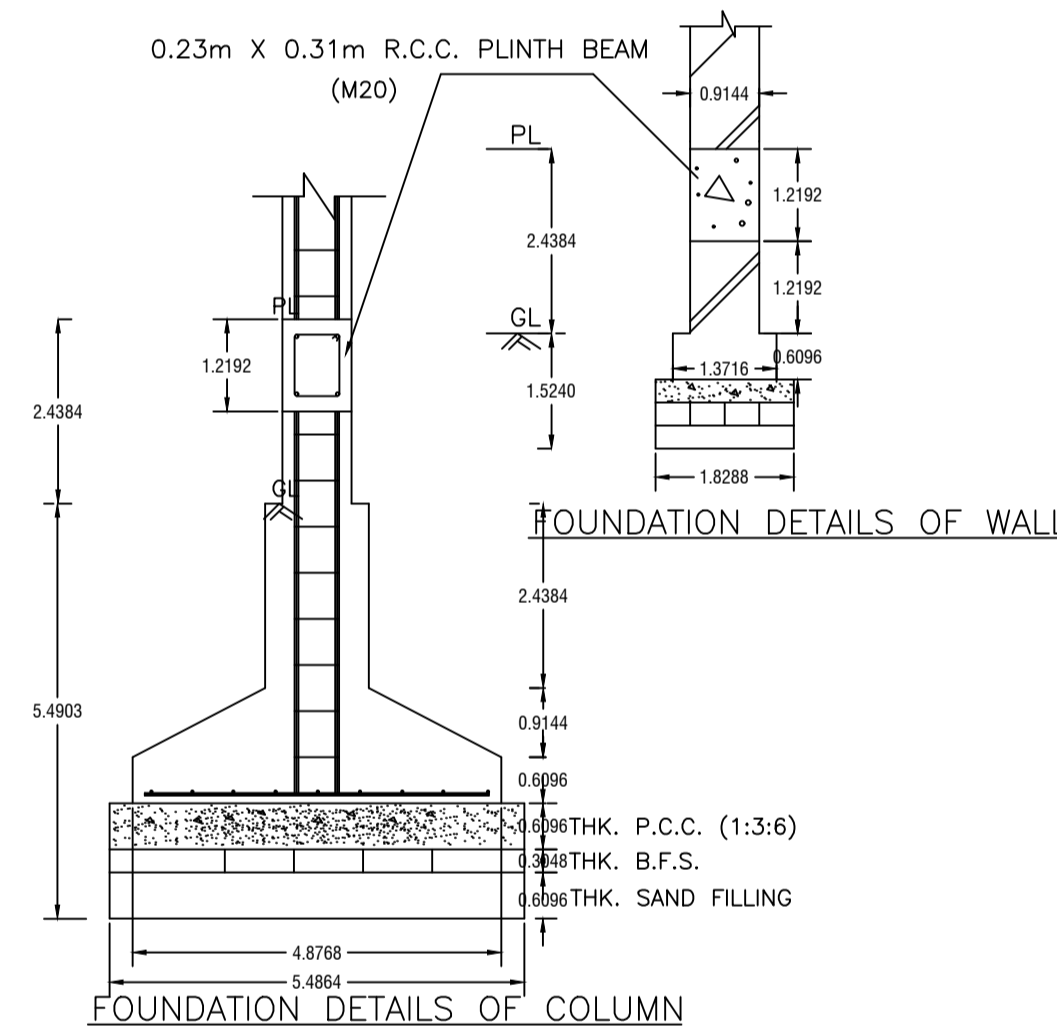

FOUNDATION DETAILS OF COLUMN

UnitBUA Table for Building :A (A)

FLOOR	Name	UnitBUA Type	UnitBUA Area	Carpet Area	No. of Rooms	No. of Tenement	
TYPICAL	- 1,	SPLIT 1	FLAT	115.23	115.21	11	2
2 FLOOR							
Total:	-	-	-	230.45	230.43	22	2

SCHEDULE OF DOOR:

BUILDING NAME	NAME	LENGTH	HEIGHT	NOS
A (A)	d	0.90	2.10	18

SCHEDULE OF WINDOW/VENTILATION:

BUILDING NAME	NAME	LENGTH	HEIGHT	NOS
A (A)	w	1.11	1.20	02
A (A)	w	1.40	1.20	02
A (A)	w	1.80	1.20	24

Building :A (A)

Floor Name	Total Built Up Area (Sq.mt.)	Deductions (Area in Sq.mt.)	Proposed FAR Area (Sq.mt.)	Add Area In FAR (Sq.mt.)	Total FAR Area (Sq.mt.)	Total Consumed Additional FAR Area (Sq.mt.)	Tnmt (No.)
Ground Floor	115.22	104.35	0.00	10.87	10.87	10.87	00
First Floor	115.23	0.00	115.23	0.00	115.23	115.23	01
Second Floor	115.23	0.00	115.23	0.00	115.23	115.23	01
Terrace Floor	0.00	0.00	0.00	0.00	0.00	0.00	00
Total :	345.68	104.35	230.46	10.87	241.33	241.33	02
Total Number of Same Buildings :	1						
Total :	345.68	104.35	230.46	10.87	241.33	241.33	02

Required Parking(Table 7a)

Building Name	Type	SubUse	Area (Sq.mt.)	Units		Car		Visitors Car		TwoWheeler			
				Reqd.	Prop.	Reqd./Unit	Reqd.	Prop.	Reqd./Unit	Reqd.	Prop.	Reqd./Unit	Reqd.
A (A)	Residential	Residential Bldg/Apartment	0	1	2.00	1.00	2	-	-	-	-	-	
			> 140	1.5	-	1	-	-	-	-	-	-	
			> 0	1	2.00	-	-	-	-	1	2	-	-
			> 0	1	2.00	-	-	-	1	1	-	-	-
			Total :	-	-	-	-	2	2	-	1	1	-

Parking Check (Table 7b)

Vehicle Type	Reqd.		Prop.	
	No.	Area	No.	Area
Car	-	-	2	25.00
Total Car	2	25.00	2	25.00
Visitor's Car Parking	-	-	1	12.50
Total Visitor Parking	1	12.50	1	12.50
TwoWheeler	-	-	3	6.00
Total TwoWheeler	2	4.00	3	6.00
Other Parking	-	-	-	60.85
Total		41.50		122.85

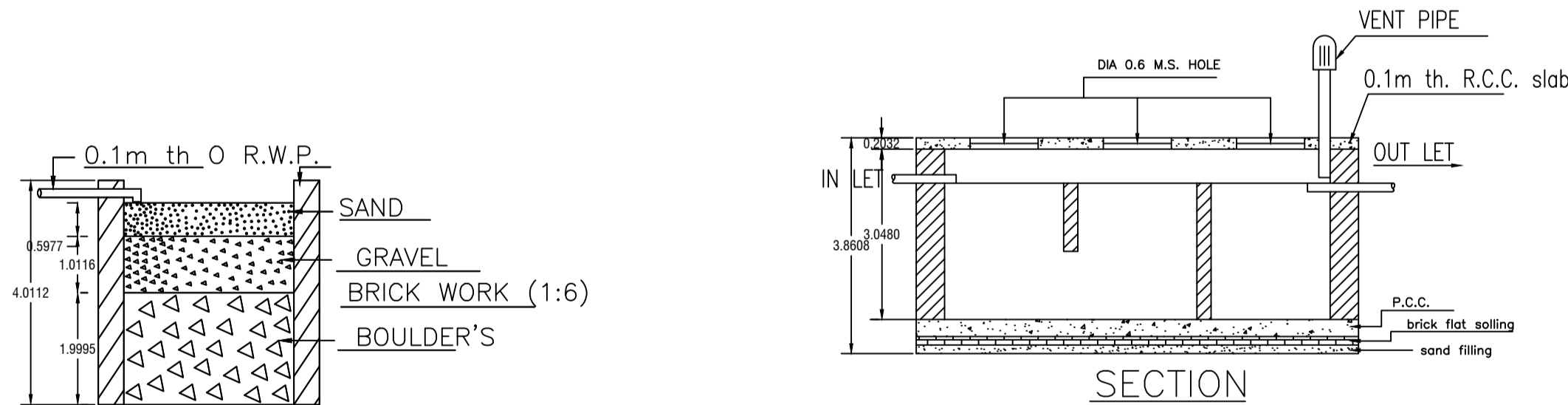

SECTION ON - AA

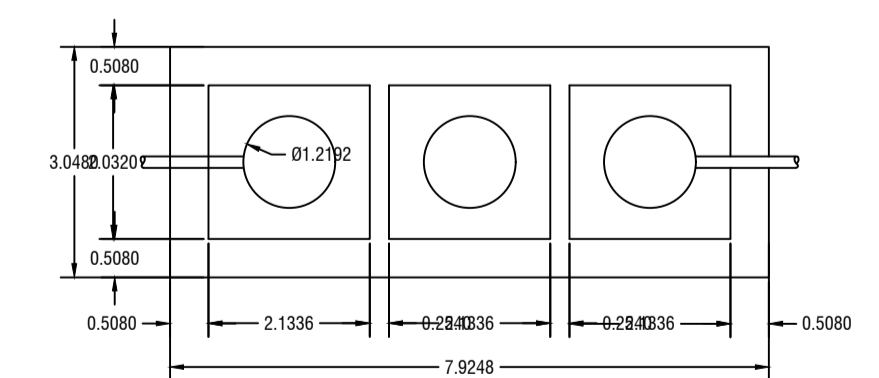

DETAILS OF SEPTIC TANK

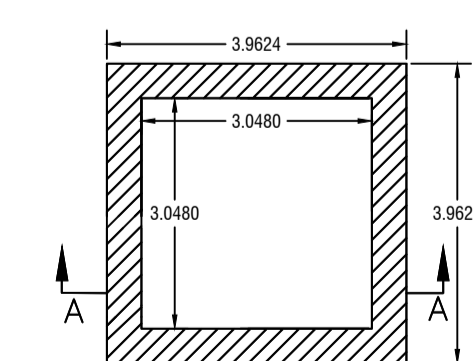

DETAIL'S OF WATER HARVESTING

LTP NAME AND SIGNATURE	STRUCTURAL ENG'S NAME AND SIGNATURE	SIGNATURE AND SIGNATURE	DATE AND SIGNATURE
SUSHIL KUMAR DMC/ENG/0005/2016			

Proposal Basic Information	
Proposal File No	DMC/BP/0309/W26/2019
Owner Name	RUPA SINGH
Khata No	06
Plot No	198/1170
Village Name	Bhuda
Use	Residential
SubUse	Bungalow/ Dwelling / Non Apartment

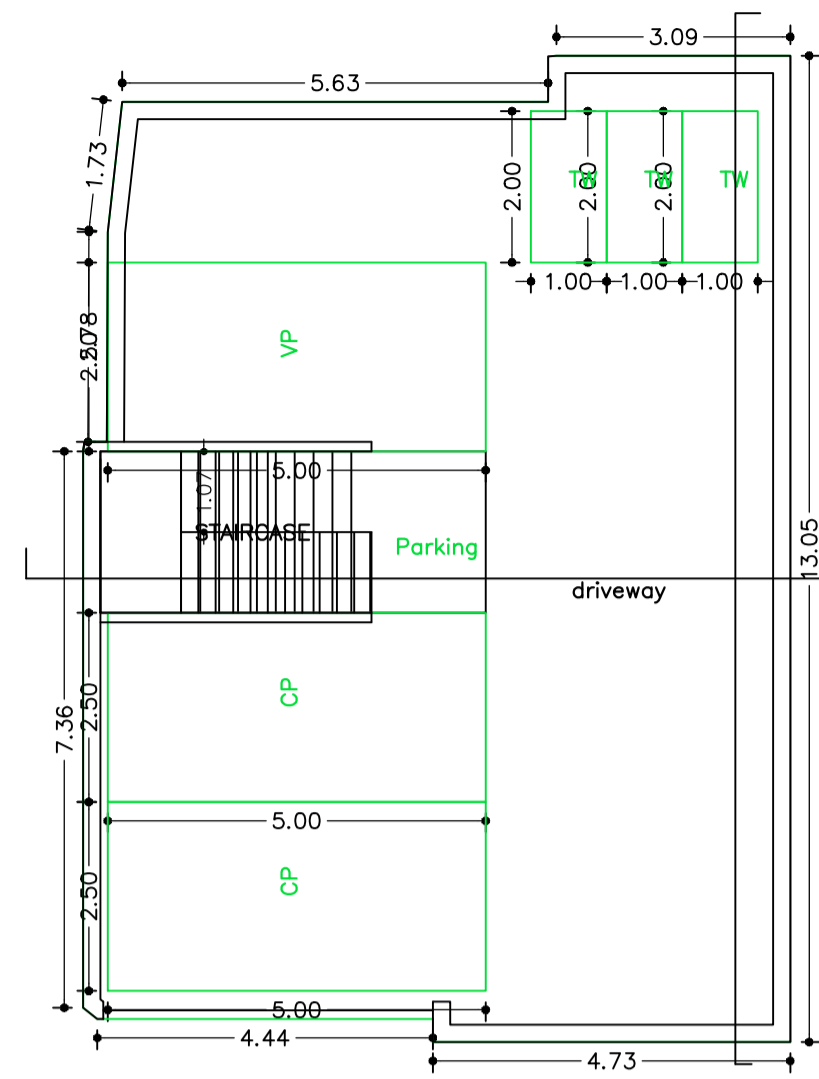

GROUND FLOOR PLAN (SCALE 1:100)

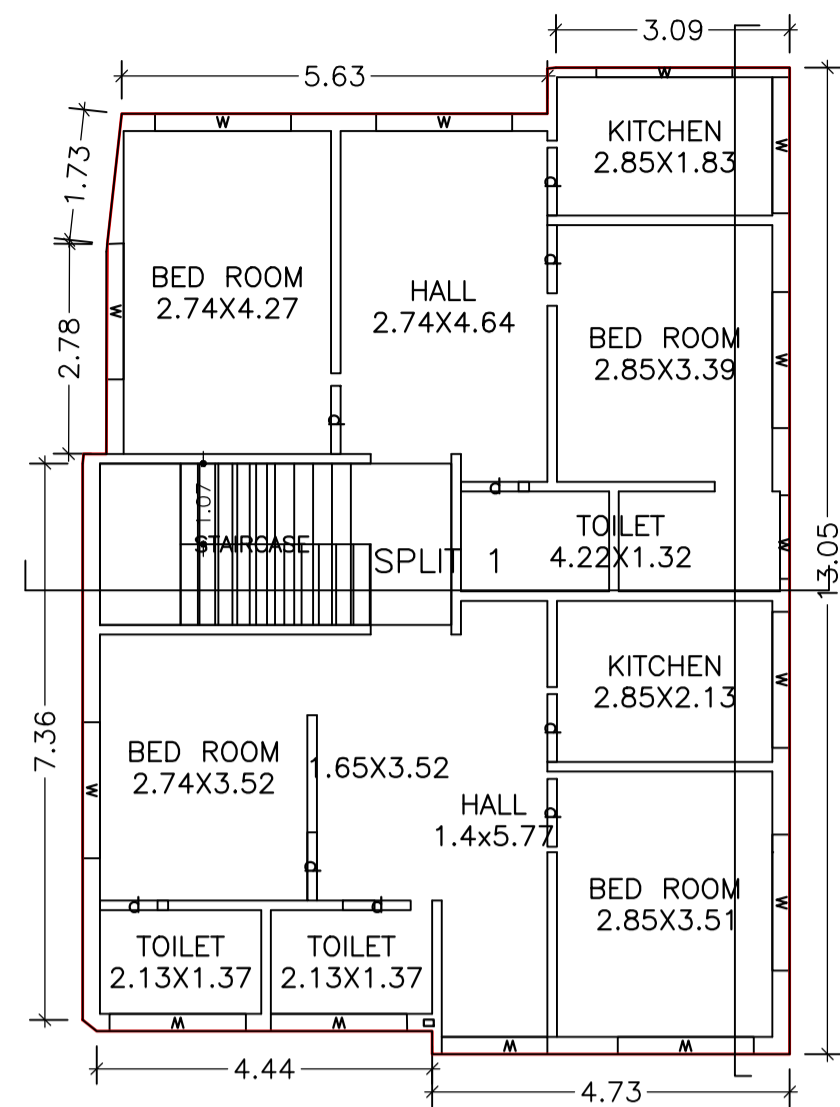

TYPICAL - 1, 2 FLOOR PLAN (Proposed) (SCALE 1:100)

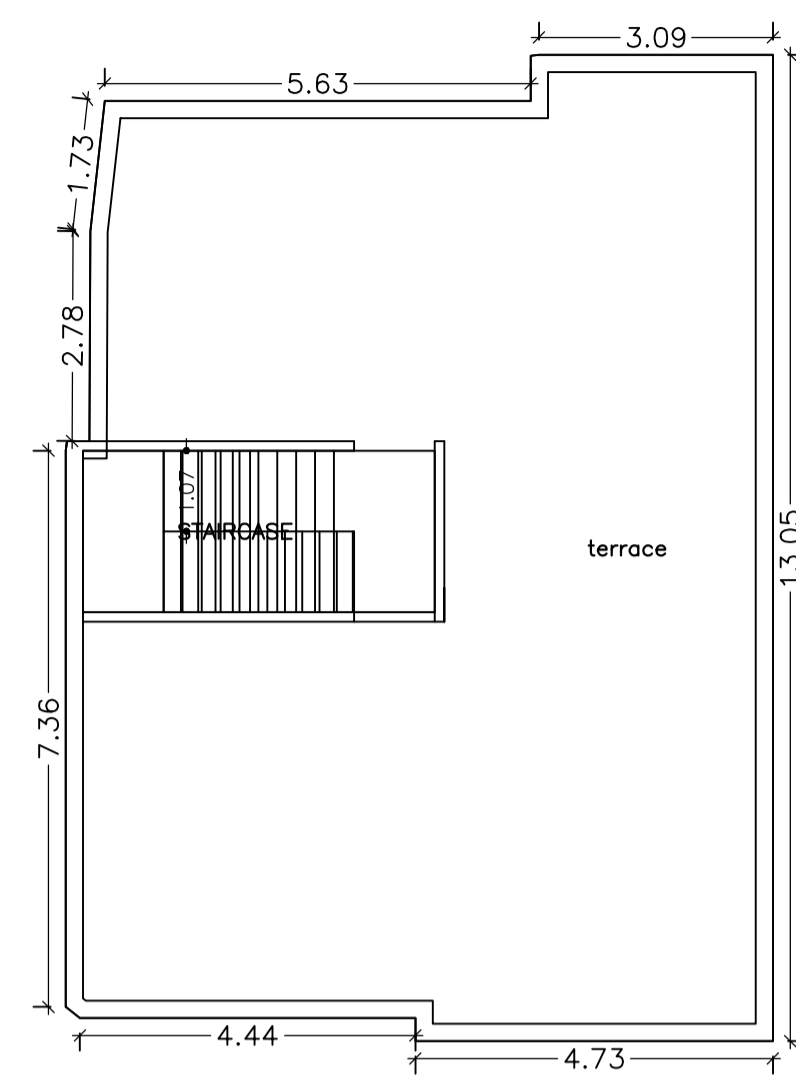

TERRACE FLOOR PLAN (SCALE 1:100)

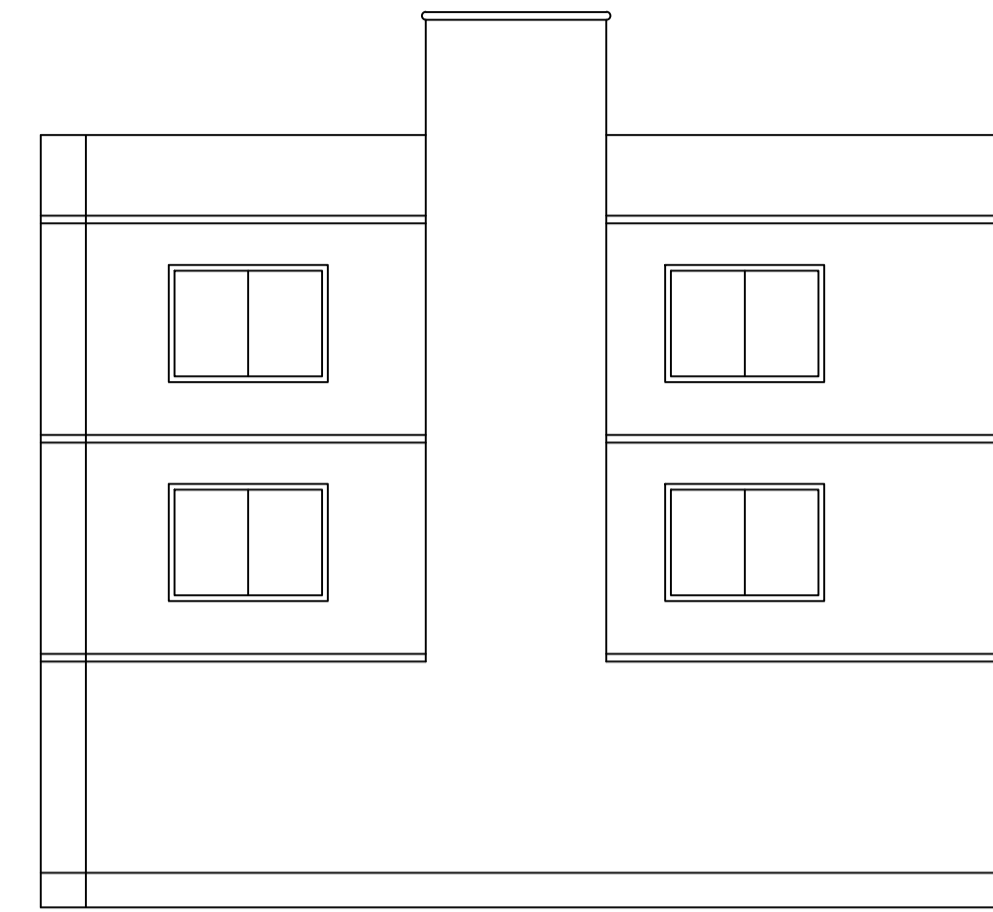

FRONT ELEVATION

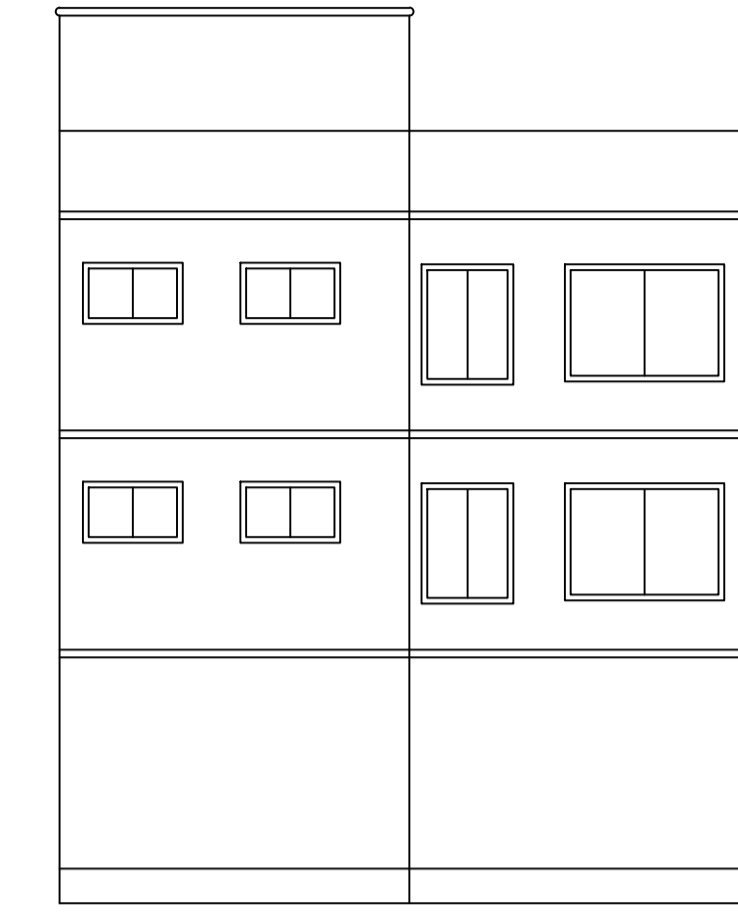

RIGHT SIDE ELEVATION

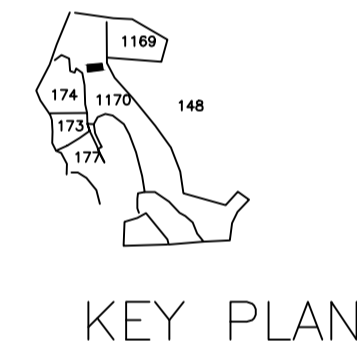

KEY PLAN

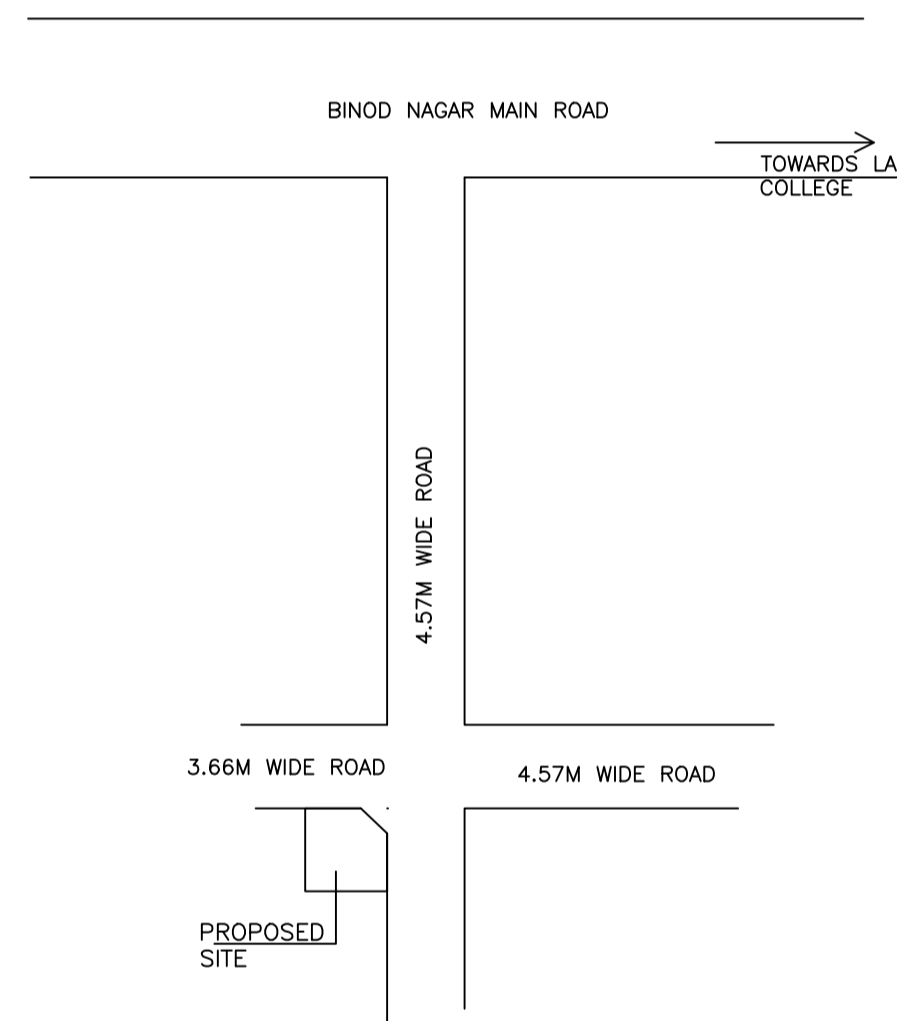

LOCATION PLAN

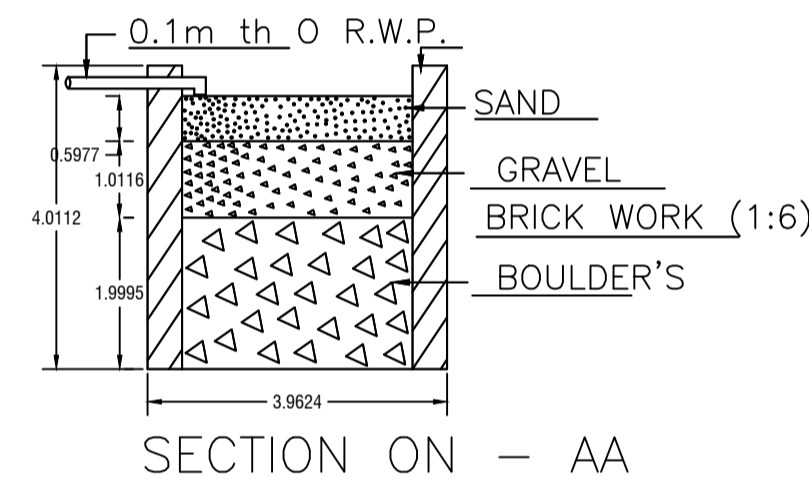

SECTION ON - AA

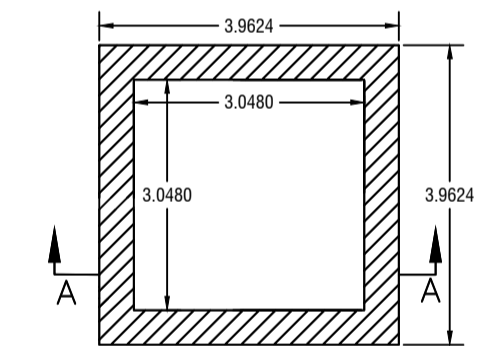

DETAIL'S OF WATER HARVESTING

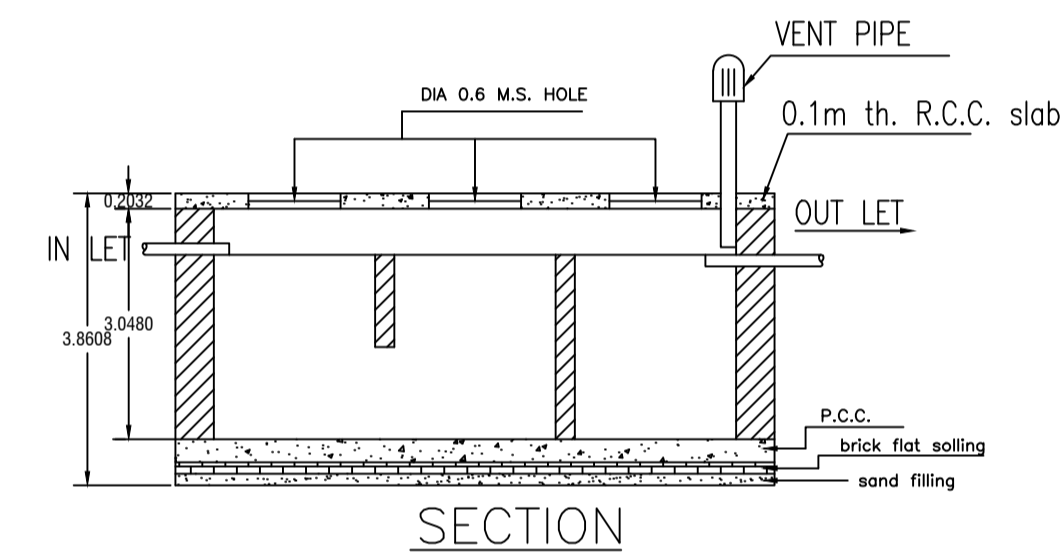

SECTION

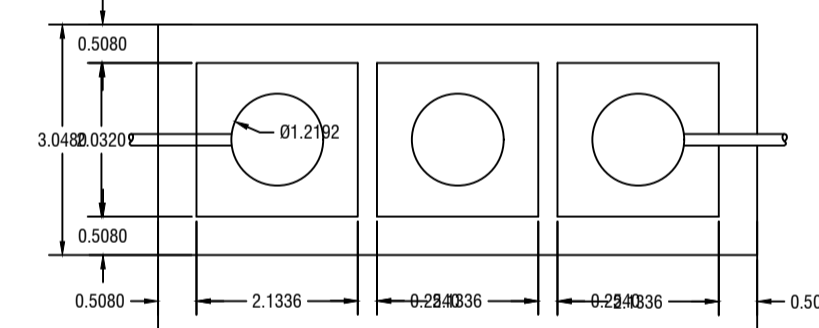

DETAILS OF SEPTIC TANK

UnitBUA Table for Building :A (A)

FLOOR	Name	UnitBUA Type	UnitBUA Area	Carpet Area	No. of Rooms	No. of Tenement
TYPICAL - 1, 2 FLOOR PLAN	SPLIT 1	FLAT	115.23	115.21	11	2
Total:	-	-	230.45	230.43	22	2

SCHEDULE OF DOOR:

BUILDING NAME	NAME	LENGTH	HEIGHT	NOS
A (A)	d	0.90	2.10	18

SCHEDULE OF WINDOW/VENTILATION:

BUILDING NAME	NAME	LENGTH	HEIGHT	NOS
A (A)	w	1.11	1.20	02
A (A)	w	1.40	1.20	02
A (A)	w	1.80	1.20	24

Building :A (A)

Floor Name	Total Built Up Area (Sq.mt.)	Deductions (Area in Sq.mt.)			Total FAR Area (Sq.mt.)	Total Consumed Additional FAR Area (Sq.mt.)	Tmmt (No.)
		Parking	Resi.	Stair			
Ground Floor	115.22	104.35	0.00	10.87	10.87	10.87	00
First Floor	115.23	0.00	115.23	0.00	115.23	115.23	01
Second Floor	115.23	0.00	115.23	0.00	115.23	115.23	01
Terrace Floor	0.00	0.00	0.00	0.00	0.00	0.00	00
Total :	345.68	104.35	230.46	10.87	241.33	241.33	02
Total Number of Same Buildings :	1						
Total :	345.68	104.35	230.46	10.87	241.33	241.33	02

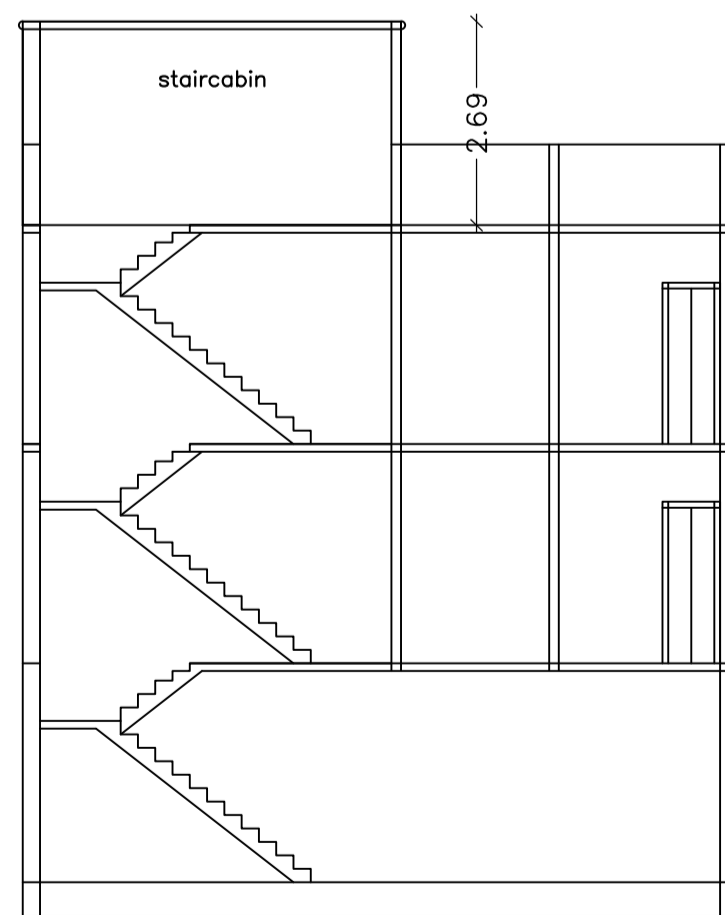

SECTION AT X-X

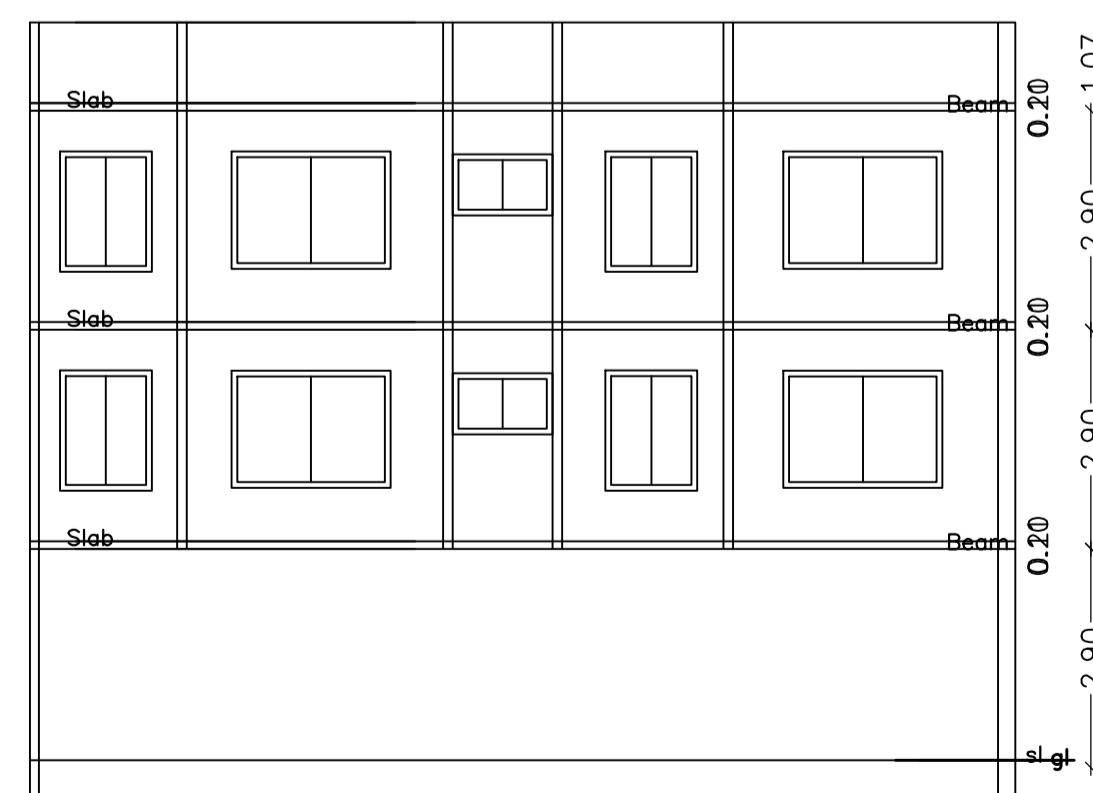

SECTION AT - YY

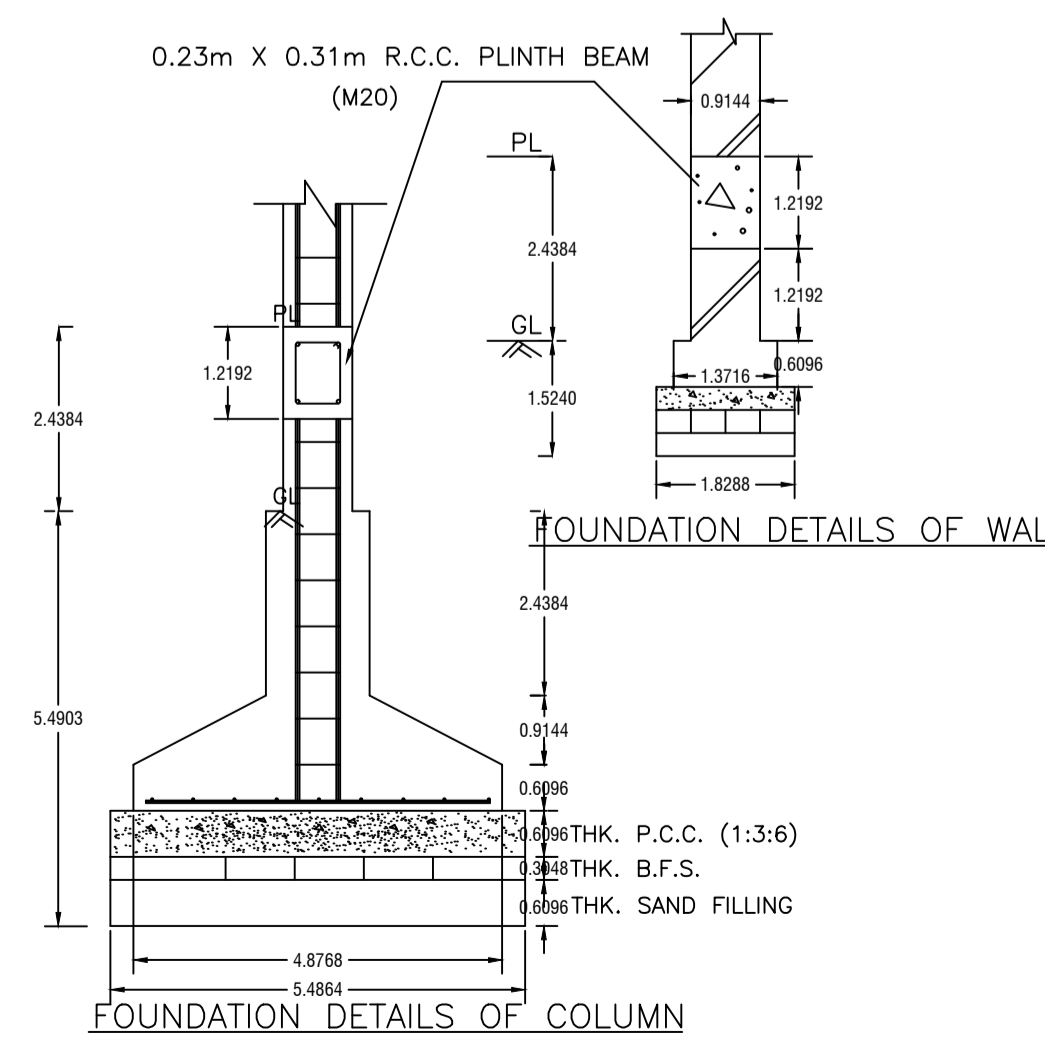

FOUNDATION DETAILS OF WALL

FOUNDATION DETAILS OF COLUMN

LTP NAME AND SIGNATURE	STRUCTURAL ENG'S NAME AND SIGNATURE	SEAL/DERNAME AND SIGNATURE	AUTOREAL SIGNATURE
SUSHIL KUMAR DMC/ENG/0005/2016			