

Project Title -SMT ANITA DEVI

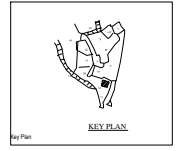
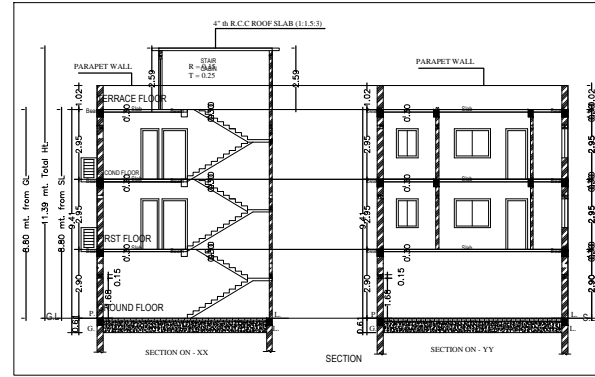
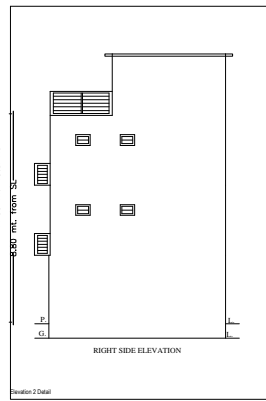
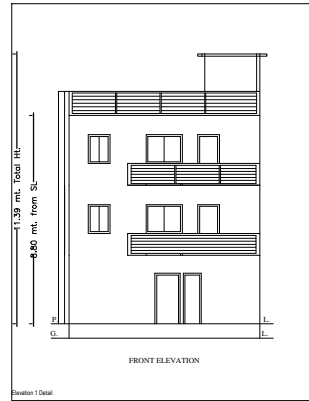

BRIEF SPECIFICATION
FOUNDATION :- R.C.C. (1:1.5:3) Column footing foundation.
PLINTH :- 0.300 R.C.C. (1:1.5:3) all round on plinth level.
FLOORING :- 0.037 I.P.S. flooring over 0.075 P.C.C. (1:2:4).
SUPER STRUCTURE :- First class brick work in cement mortar (1:6)
SLAB,BEAM & LINTEL :- All R.C.C. work (1:1.5:3).
WOOD WORK :- All door & window frames of sal wood.
PLASTERING :- 0.012 cement plaster (1:6) both side.
COLUMN FOOTING :- Mark in plan just of positioning of column.

SCHEDULE

D-	1.000 x 2.100	W-	1.820 x 1.200
D1-	0.900 x 2.100	W1-	1.800 x 1.200
D2-	0.750 x 2.100	W2-	0.900 x 1.200
		V-	0.600 x 0.450

DETAILS OF AREA

TOTAL AREA (AS PER DEED)	108.49 Sqmt.
TOTAL AREA (AS PER SITE)	104.57 Sqmt.
GROUND FLOOR AREA	59.92 Sqmt.
FIRST FLOOR AREA	64.25 Sqmt.
SECOND FLOOR AREA	64.25 Sqmt.
TOTAL COVERED AREA	188.42 Sqmt.
% OF PLINTH AREA	57.30 %
F.A.R	1.80

TITLE OF DRAWING
 PROPOSED RESIDENTIAL BUILDING PLAN OF SMT. ANITA DEVI W/O - SRI AKHILESH PRASAD.BHULLI - E-BLOCK, SECTOR - 5, QUA - 217,P.O - BHULLI NAGAR,P.S - BANK MORE,DIST - DHANBAD, UNDER MOUZA - BISHUNPUR, MOUZA NO - 5, KHATA NO-01, NEW KHATA - 226, PLOT NO -74, NEW PLOT - 113 IN DIST DHANBAD (JHARKHAND).

SIG. OF OWNER

SIG. OF ENGINEER

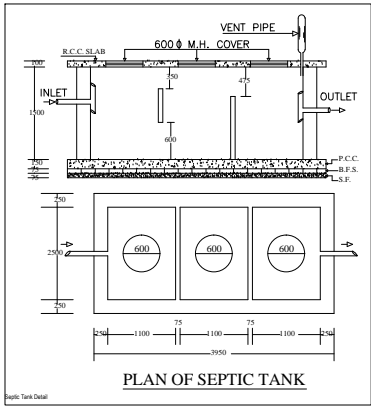
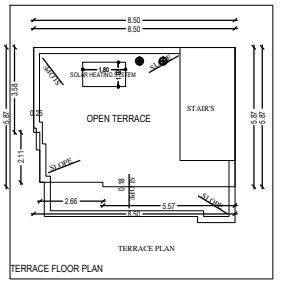
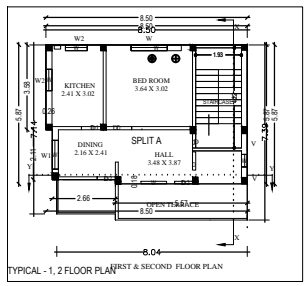
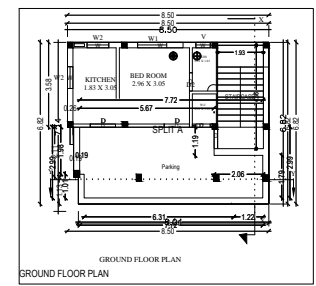
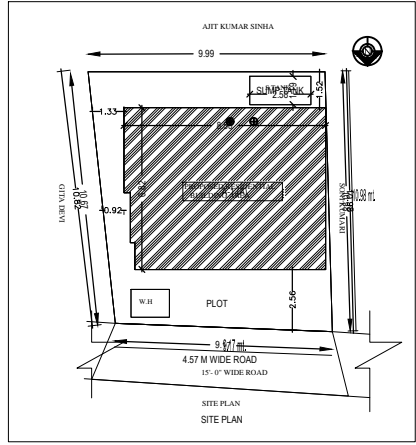
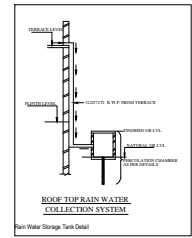
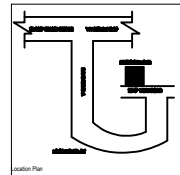
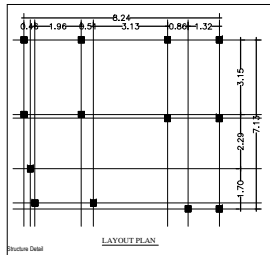
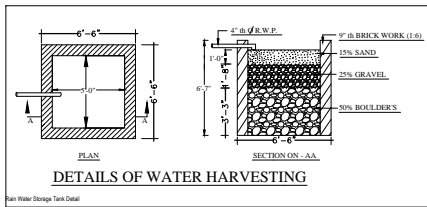

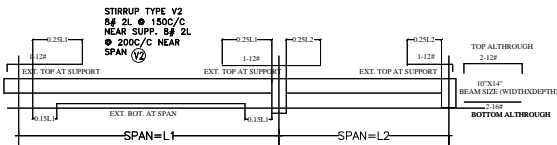
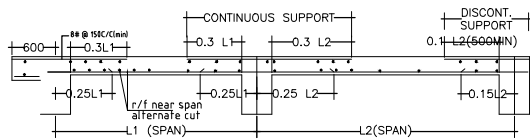

LEGEND OF R/F SHOWN IN THE DRAWING

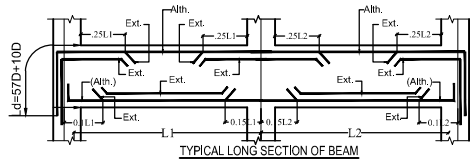

TYPICAL LONG SECTION OF BEAM

LEGEND

- R/F HAVING "L" ON BOTH SIDES
- R/F HAVING "L" ON ONE SIDE, THE OTHER BEING STRAIGHT
- STRAIGHT R/F

STIRRUPS DETAILS

TYPE	DIA	NO. OF LEGS	STIRRUP SPACING	
			NEAR SUPP.	NEAR SPAN
V1	8#	2-LEGGED	200C/C	200C/C
V2	8#	2-LEGGED	150C/C	200C/C
V3	8#	2-LEGGED	150C/C	150C/C
V4	8#	2-LEGGED	100C/C	100C/C

SPECIAL NOTES
BEAMS FOR WHICH STIRRUP TYPE HAS NOT BEEN MARKED SHALL HAVE V1 STIRRUP TYPE.

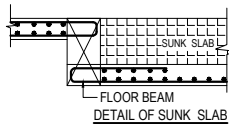

DETAIL OF SUNK SLAB

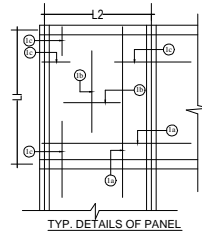

TYP. DETAILS OF PANEL

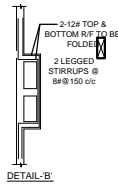

DETAIL-B

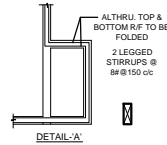

DETAIL-A

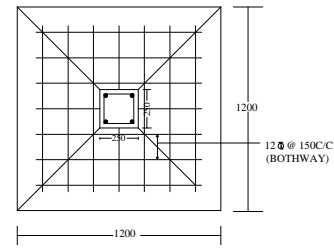

DETAIL OF COLUMNS

