

Project Title : SMT NANDANI KUMARI

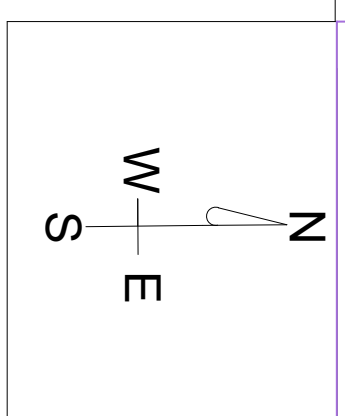
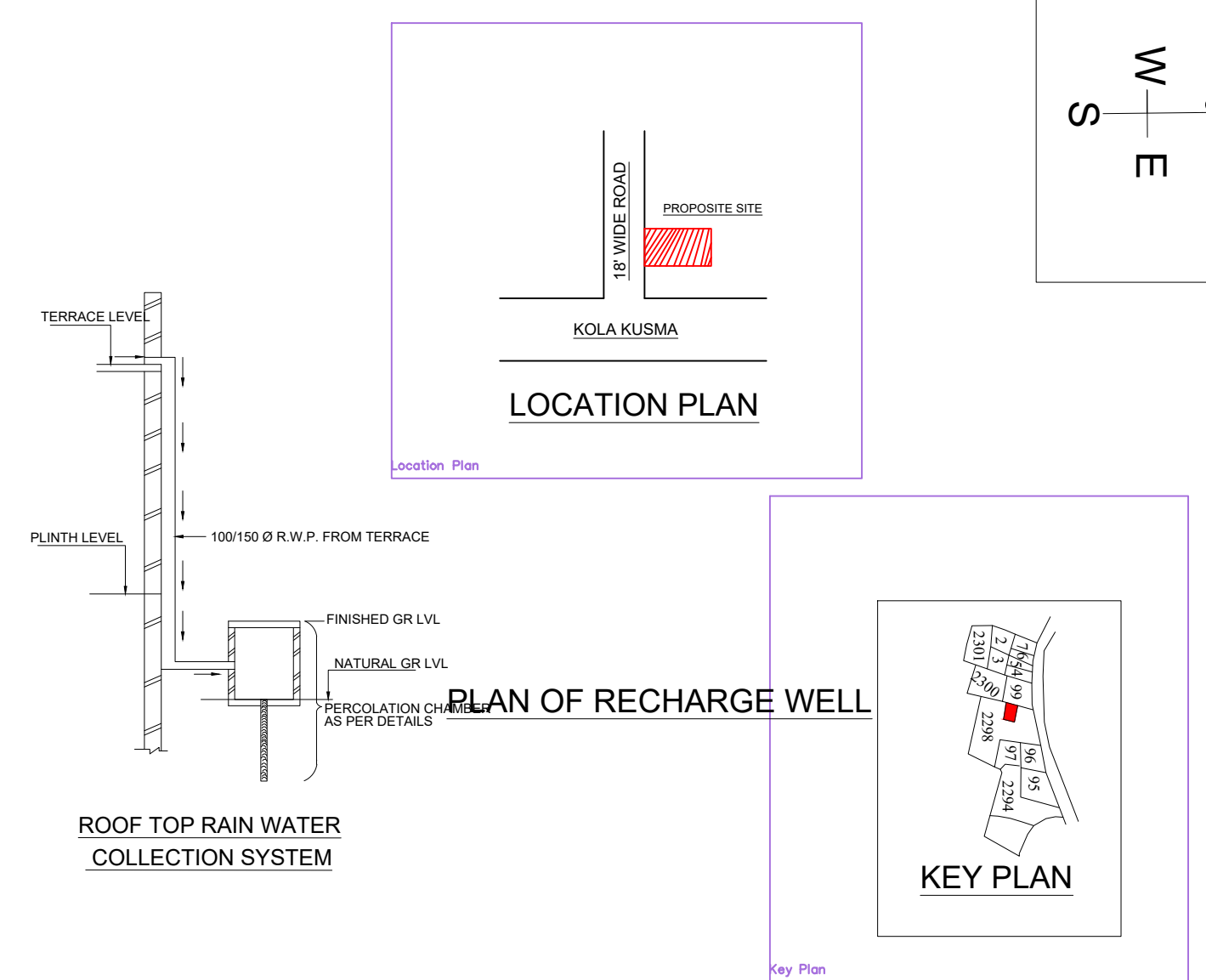
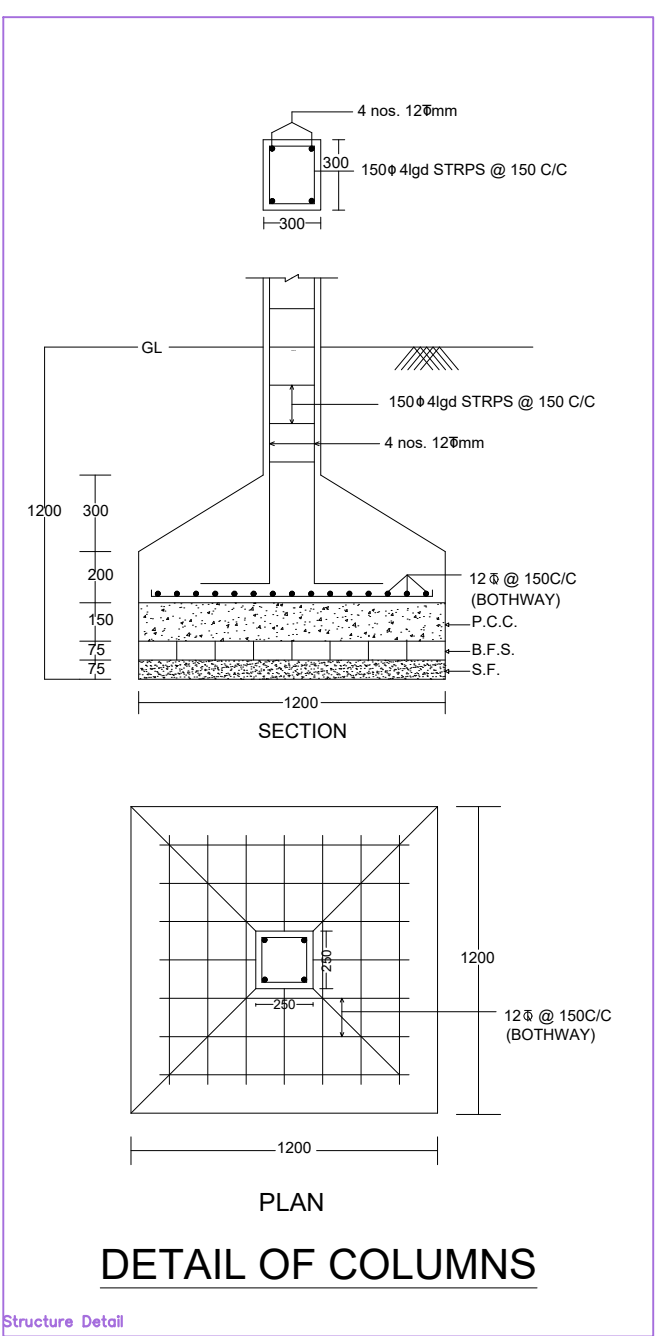
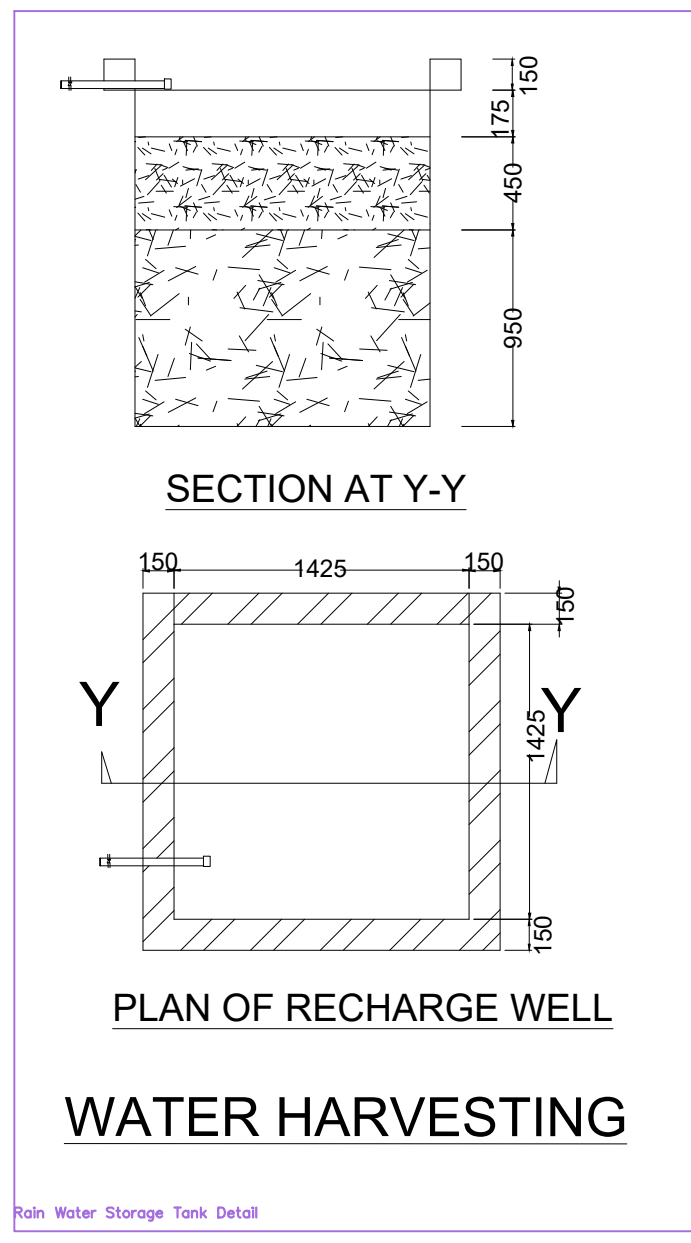
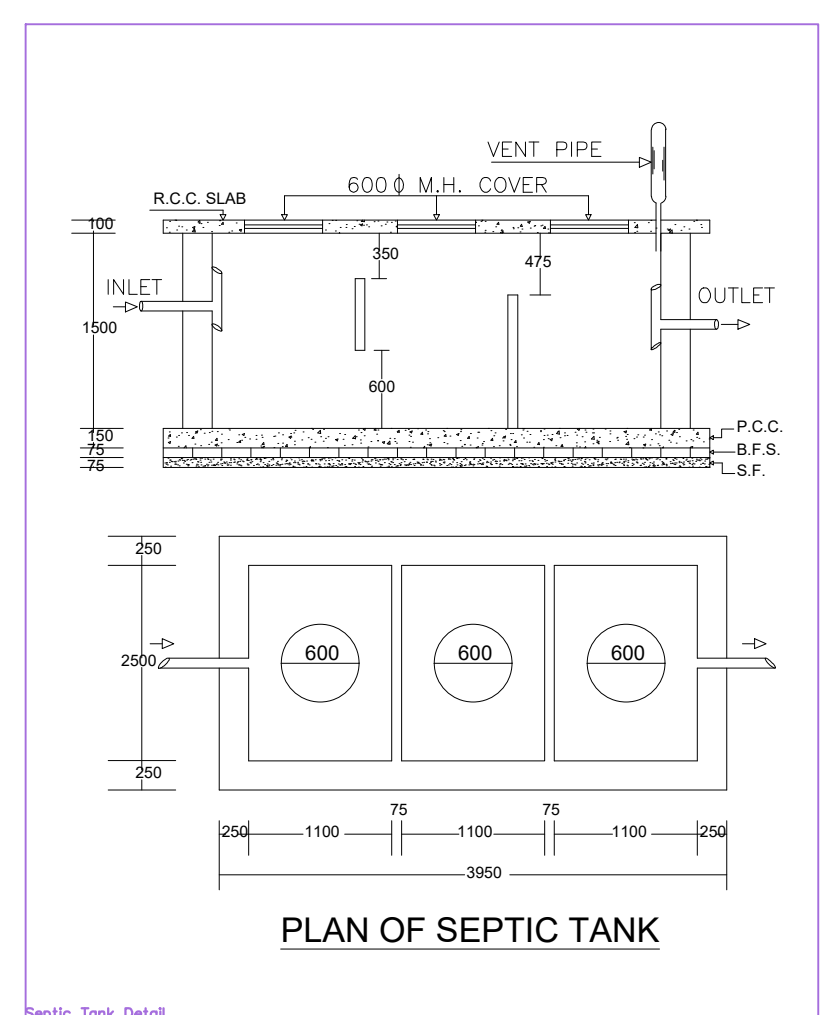
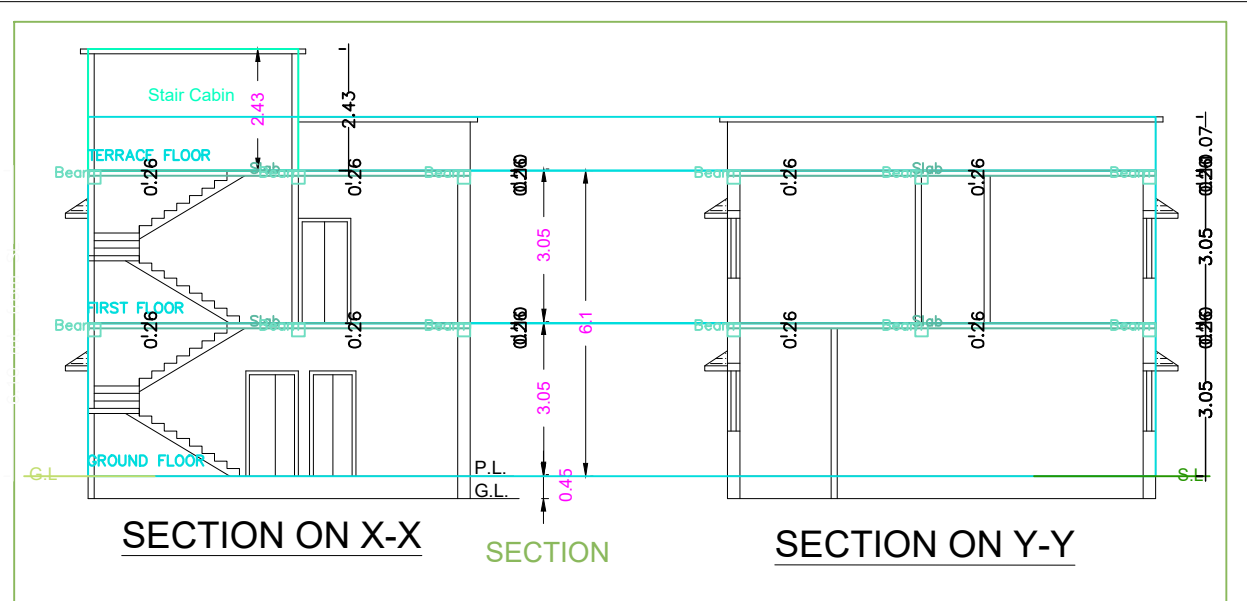
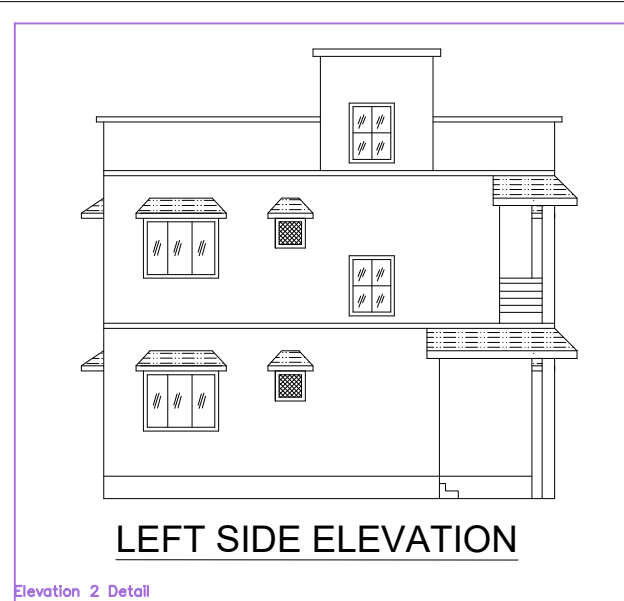
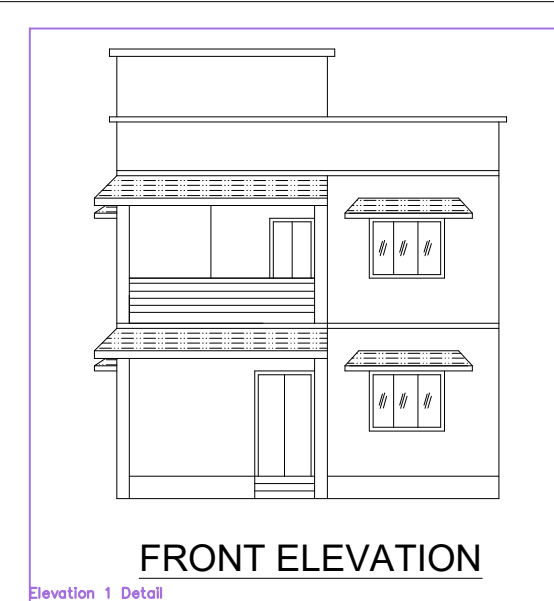

BRIEF SPACEFICATION
 FOUNDATION----- CEMENT CONCRETE (1:1.5:3)
 BRICK WORK IN FOUNDATION & SUPERSTRUCTURE
 FIRST CLASS BRICK WORK IN CEMENT MORTAR (1:6)
 D.P.C.-----25 D.P.C. IN CEMENT CONCRETE (1:2:4)
 FLOOR-----25 I.P.S. OVER 75 P.C.C.
 ROOF-----100 THK. R.C.C. ROOF (1:1.5:3)
 LINTEL-----150 THK. R.C.C. LINTEL (1:1.5:3)
 STAIRS----- RISE-- 150, TREAD-- 250

DETAILS OF AREA

TOTAL AREA (AS PER DEED)	106.43 SQM.
TOTAL AREA (AS PER SITE)	106.36 SQM.
GROUND FLOOR AREA	67.12 SQM.
FIRST FLOOR AREA	67.12 SQM.
TOTAL COVERED AREA	134.24 SQM.
% PLINTH AREA	59.62 %
FAR	1.25

SCHEDULE

D	=	1.200X2.100	W1	=	1.500X1.200
D1	=	1.050X2.100	W2	=	1.200X1.200
D2	=	0.900X2.100	V	=	0.600X0.600

TITLE OF DRAWING
 PLAN OF PROPOSED RESIDENTIAL BUILDING OF SMT. NANDANI KUMARI W/O SRI. RAVINDRA KUMAR CHOURASIA OF BHAGA NO.4 (PASWAN COLONY), P.O.- BHAGA, P.S. - JHARIA, DHANBAD, UNDER MOUZA - KOLAKUSMA, NO.- 12, KHATA NO.- 30, NEW KHATA NO. 600, PLOT NO.- 1723 NEW PLOT NO.- 2298 IN THE DISTT. OF DHANBAD (JHARKHAND).

SIGNATURE OF OWNER

SIGNATURE OF ENGINEER

SCALE ALL DIMENSION ARE IN METRE

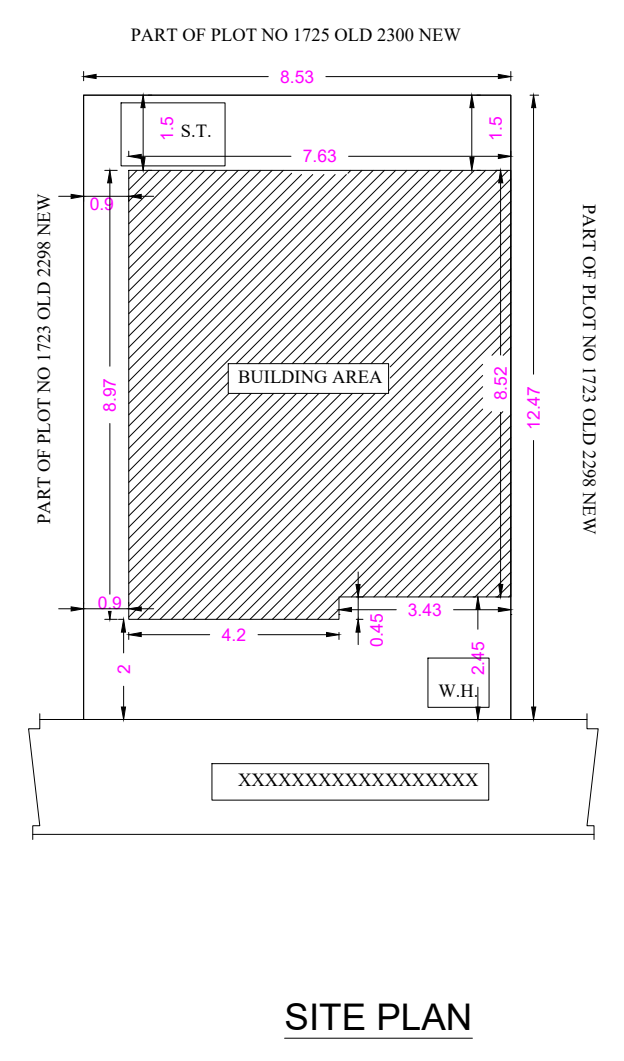
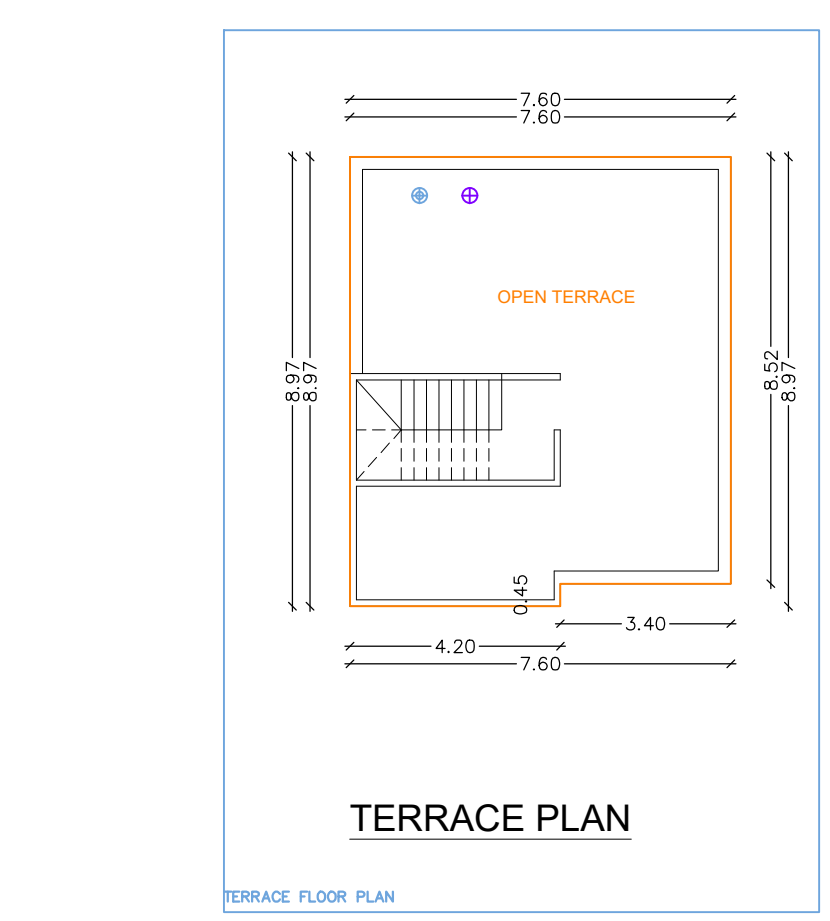
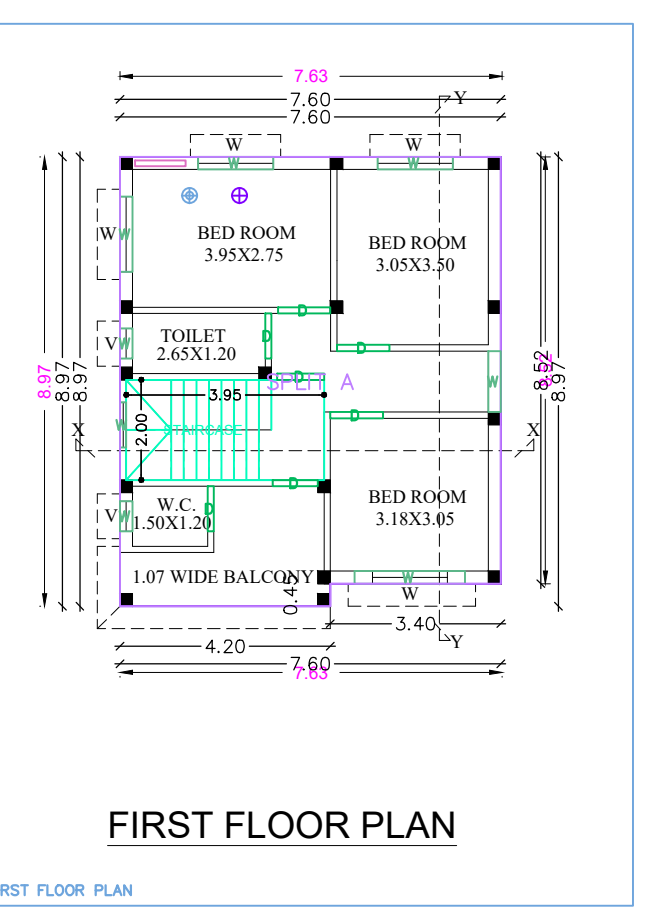
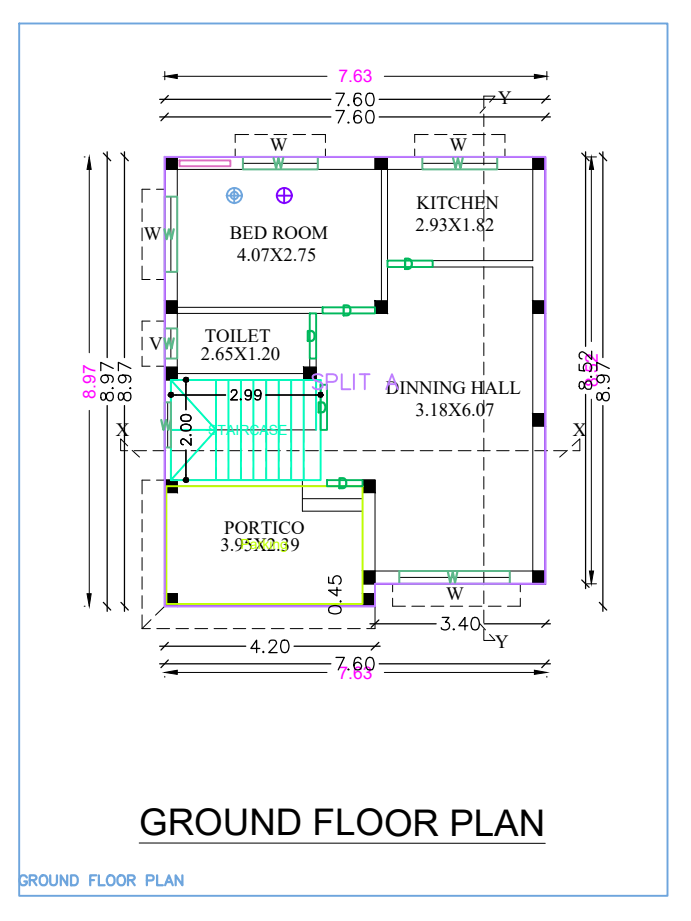
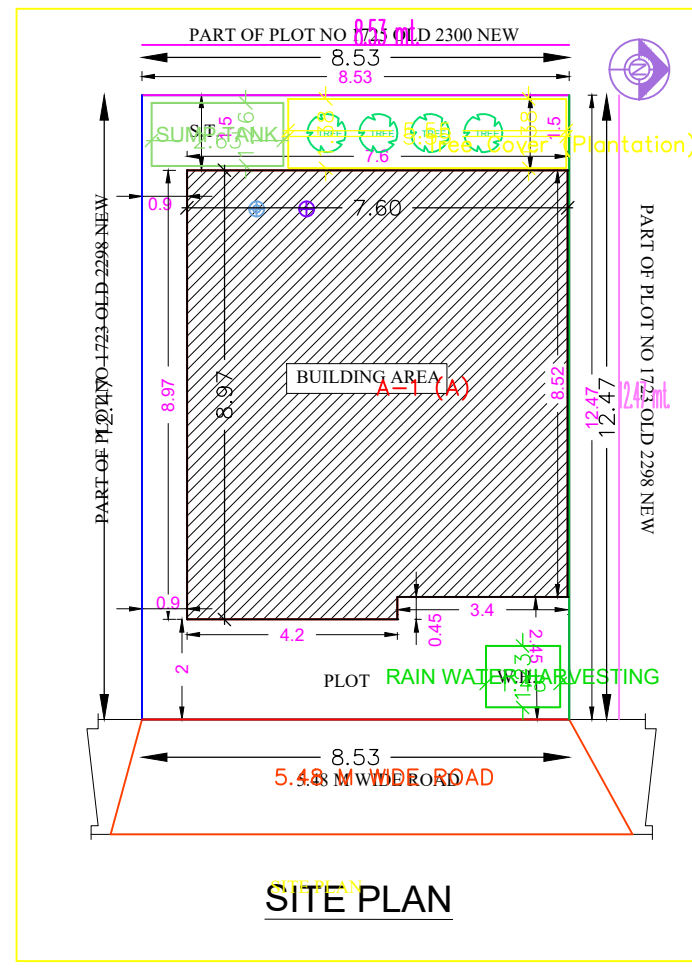

Building 'A' (A)

Floor Name	Total Built Up Area (Sq.mt)	Proposed FAR Area (Sq.mt)	Total FAR Area (Sq.mt)	Tent (No)
Ground Floor	66.66	66.66	66.66	01
First Floor	66.66	66.66	66.66	00
Terrace Floor	0.00	0.00	0.00	00
Total	133.32	133.32	133.32	01

SCHEDULE OF JOINERY:

BUILDING NAME	NAME	LENGTH	HEIGHT	NOS
A(A)	D	0.71	2.10	01
A(A)	D	1.50	2.10	06
A(A)	D	0.94	2.10	01
A(A)	D	1.04	2.10	01
A(A)	D	1.05	2.10	03
Total	-	-	-	12

SCHEDULE OF JOINERY:

BUILDING NAME	NAME	LENGTH	HEIGHT	NOS
A(A)	W	0.60	1.20	03
A(A)	W	0.90	1.20	02
A(A)	W	1.22	1.20	01
A(A)	W	1.50	1.20	06
A(A)	W	2.22	1.20	02
Total	-	-	-	14

Unit/BUA Table for Building 'A' (A)

FLOOR	Name	Unit/BUA Type	Unit/BUA Area	Carpet Area	No. of Rooms	No. of Tenement
GROUND FLOOR	SPLIT A	FLAT	133.33	133.09	4	1
Total	-	-	133.33	133.09	11	1

AREA STATEMENT (DHANBAD MUNICIPAL CORPORATION)	VERSION NO. 1.0.01
PROJECT DETAIL	VERSION DATE: 01/10/2019
Plot No. : Residential	
Region : JHARKHAND URBAN LOCAL BODIES	Plot Name : Residential Dwelling / Non Apartment
Zone : DHANBAD	Land Use Zone : Residential
Application Type : General Proposal	Mounting Road Width :
Project Type : Building Permission	Plot No. :
Name of Developer : New	Revenue Survey No./Survey No. :
Location : Old Area	Thana No. :
ESL Location : NA	Ward No. :
Village/Block Name : -	Phase No. :
Ward No. : -	North : -
Road/Street : -	South : -
	East : -
	West : -

AREA DETAILS		30.00
AREA OF PLOT (Sqm)	(A)	106.37
Net Plot Area (Gross Plot Area - Deduction from Gross Plot Area)	(A-Deductions)	106.37
Deductions for Balance Plot Area (from Gross Plot Area)		
Plot Area		7.66
Balance Plot Area (Net Plot Area - Recreational Amenity Area)	(A-Deductions)	98.69
Plot Area for Coverage (Net Plot Area)	(A-Deductions)	106.37
Plot Area for FSI (Net Plot Area + Recreational Amenity Area)	(A-Deductions)	106.37
COVERED AREA CHECK		
Proposed Coverage Area (62.67 %)		66.66
Max. Coverage Area (62.67 %)		66.66
FAR CHECK		
Proposed Area of FAR		133.32
Total Area of FAR		133.32
BUILD UP AREA CHECK		
Total Proposed Build Up Area		133.32
APPROX. CHECK (SUPERVISOR/ Regt)		OWNER

DEVELOPMENT AUTHORITY	LOCAL BODY
-----------------------	------------

COLOR INDEX	
Plot Boundary	
Proposed Work (Coverage Area)	
Existing (To be retained)	
Existing (To be demolished)	

PARKING CALCULATION		
Parking Type	Prop. No.	Prop. Area
Other Parking	1	0.25
Total Area	1	0.25

MARGIN DETAIL:				
Building / Wing Name	Road Name	Front Margin	Rear Margin	Side Margin
A (A)	SRI M. WIDE ROAD	2.00	1.50	0.80
				0.00

FAR & Tenement Details (Table 4c-1)					
Building	No. of Same Bldg	Total Built Up Area (Sq.mt)	Proposed FAR Area (Sq.mt)	Total FAR Area (Sq.mt)	Tent (No.)
A (A)	1	133.32	133.32	133.32	01
Grand Total	1	133.32	133.32	133.32	01