

SITE PLAN
SITE PLAN

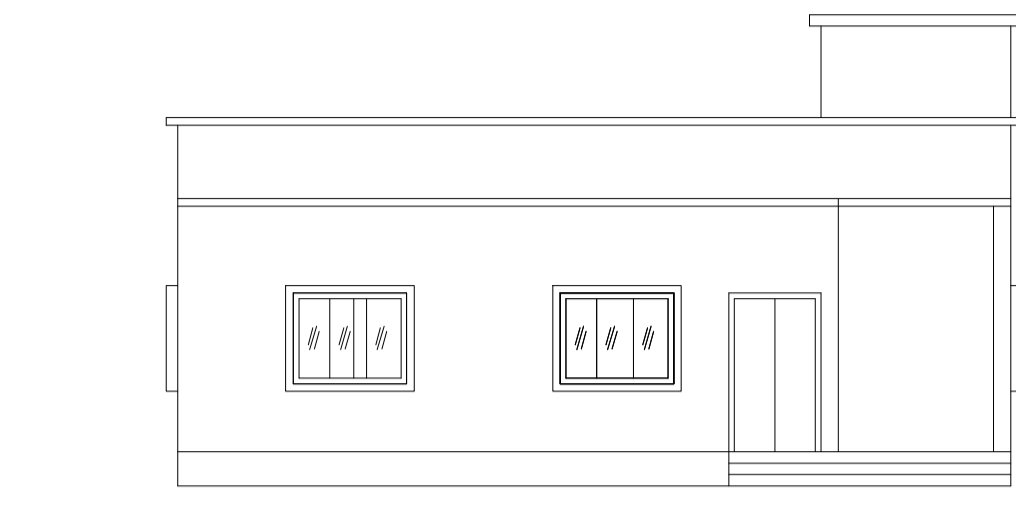

FRONT ELEVATION

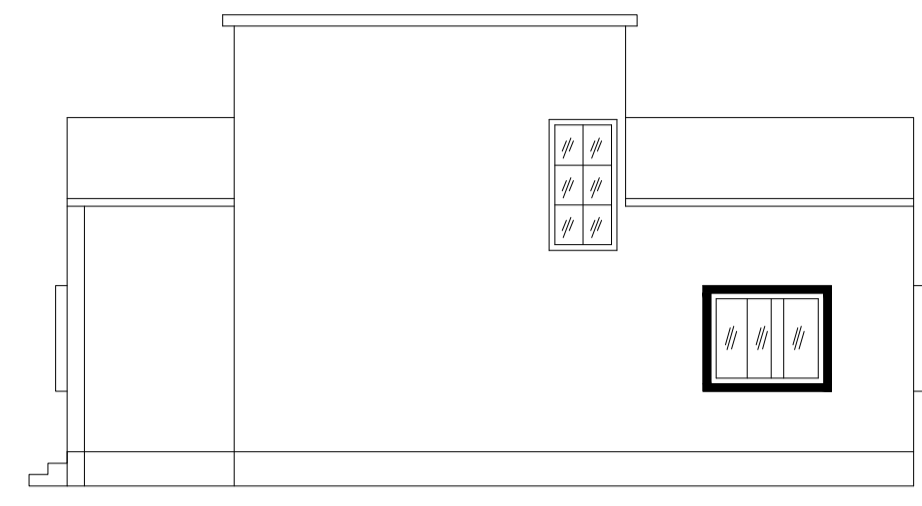

RIGHT SIDE ELEVATION

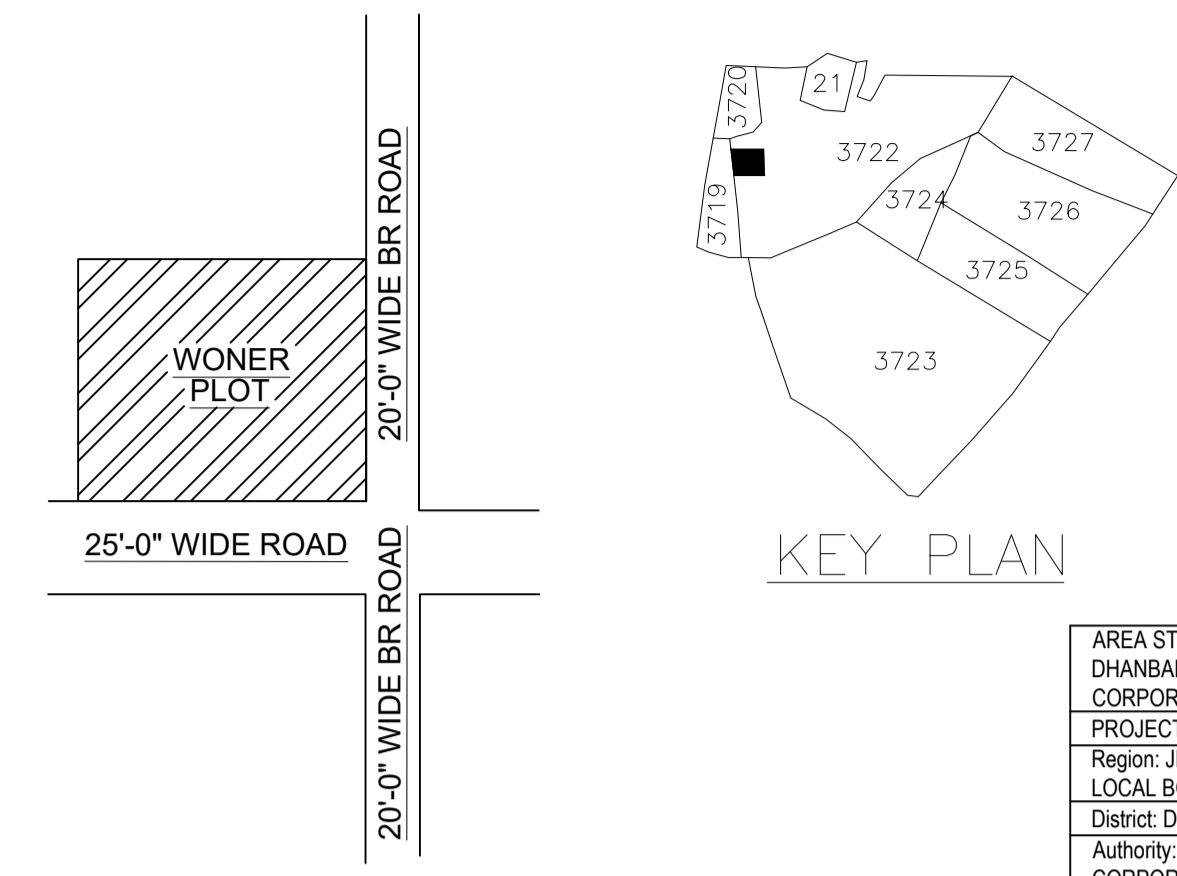

LOCATION PLAN

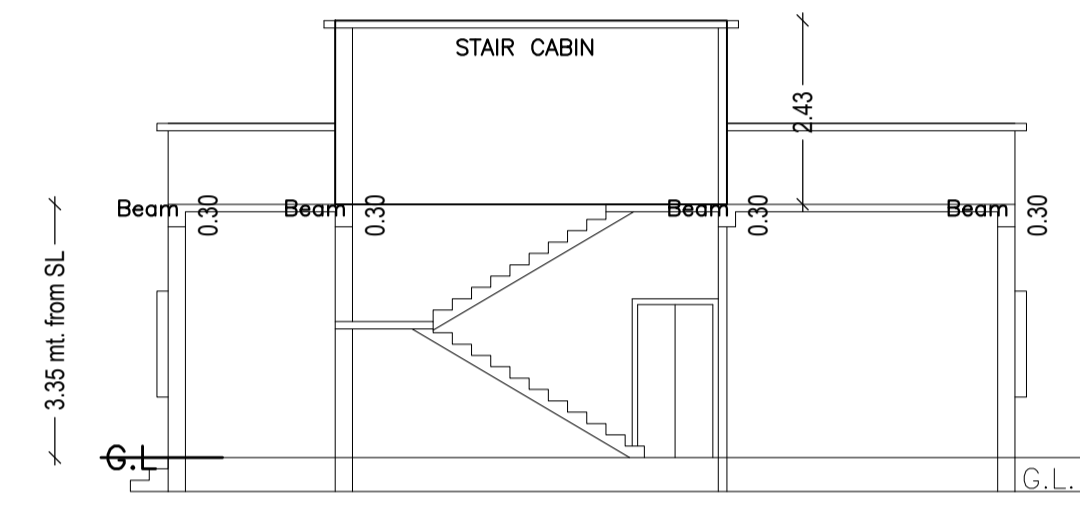

SECTION ON X-X

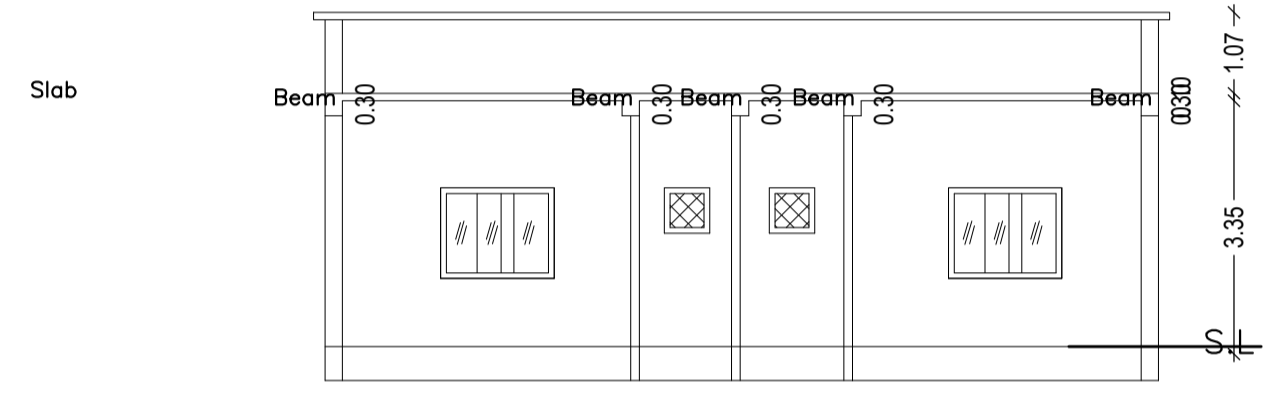

SECTION ON Y-Y

AREA STATEMENT		VERSION NO. : 1.0.42
DHANBAD MUNICIPAL CORPORATION		VERSION DATE: 29/04/2019
PROJECT DETAIL:		
Region: JHARKHAND URBAN LOCAL BODIES	Plot Use: Residential	
District: DHANBAD	Plot SubUse: Bungalow/ Dwelling / Non Apartment	
Authority: DHANBAD MUNICIPAL CORPORATION	PlotNearbyReligiousStructure: NA	
Inward No: DMC/BP/0305/W23/2019	Plot/SubPlot No: 2826 (Old), 3722 (New)	
Application Type: General Proposal	North: Plot No. - PLOT NO. 3722 KA ANSH	
Project Type: Building Permission	South: Road Width - 25 FEET CHORA PROPOSED RASTA	
Nature of Development: New	East: Road Width - 20 FEET CHORA PROPOSED RASTA	
Location of Development Area: Old Area	West: Plot No. - PLOT NO. 3722 KA ANSH	
AREA DETAILS:		SQ.MT.
AREA OF PLOT (Minimum)	(A)	200.52
NET AREA OF PLOT(Gross Plot Area - Deduction from Gross Plot area)	(A-Deductions)	200.52
Deduction for Balance Plot Area(from Gross Plot Area)		
Common Plot		12.45
Total		12.45
BALANCE AREA OF PLOT(Net Plot Area - Recreational/Amenity space)	(A-Deductions)	188.06
PLOT AREA FOR COVERAGE(Net Plot Area)	(A-Deductions)	200.52
Plot Area for FAR (Net Plot Area + RoadWidening Area)	(A-Deductions)	200.52
COVERAGE CHECK		
Permissible Coverage area (70.00 %)		140.36
Proposed Coverage Area (61.58 %)		123.48
Total Prop. Coverage Area (61.58 %)		123.48
Balance coverage area (8.42 %)		16.88
FAR CHECK		
Perm. FAR Area (2.50)		501.30
Total Perm. FAR area		501.30
Residential FAR		123.48
Proposed FAR Area		123.48
Total Proposed FAR Area		123.48
Consumed FAR (Factor)		0.62
Balance FAR Area		377.82
BUILT UP AREA CHECK		
Total Proposed BuiltUp Area		123.48
ARCHITECT (Regd)		PARTHA - PAL
ENGINEER (Regd)		
SUPERVISOR (Regd)		
OWNER (Regd)		SMT. NITU BARNWAL
DEVELOPMENT AUTHORITY		LOCAL BODY

COLOR INDEX	
PLOT BOUNDARY	Black
ABUTTING ROAD	Red
PROPOSED CONSTRUCTION	Green
COMMON PLOT	Yellow
ROAD WIDENING AREA	Blue
EXISTING (To be retained)	Light Blue
EXISTING (To be demolished)	Orange

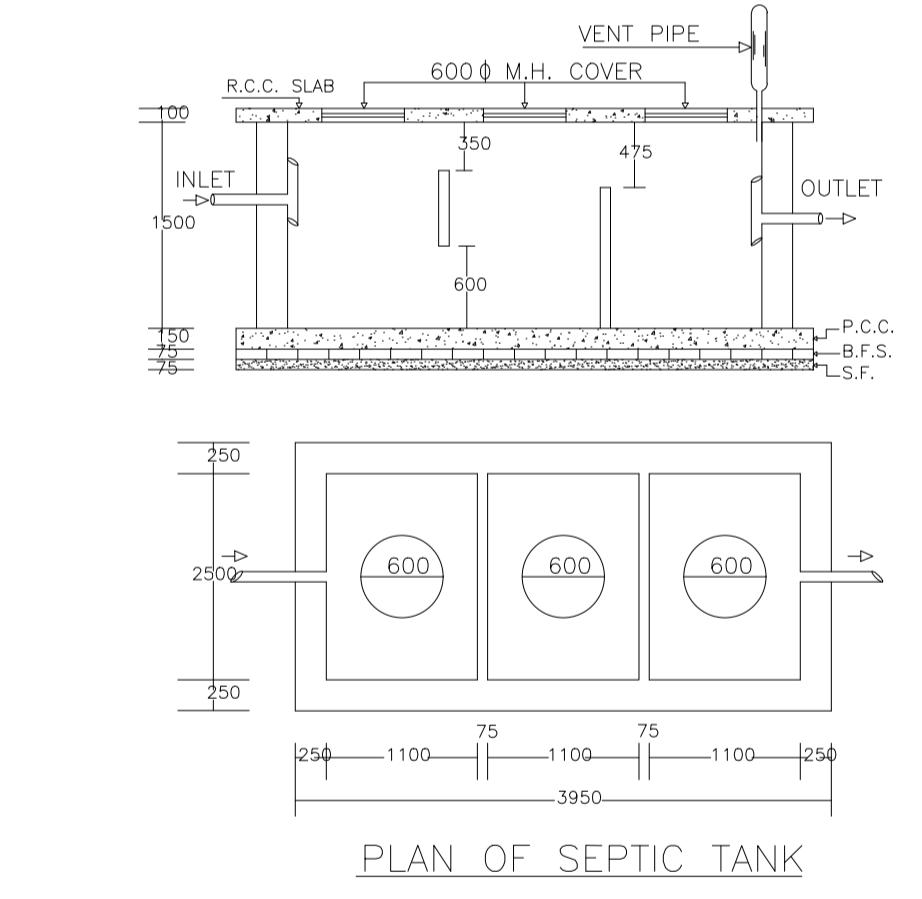

PLAN OF SEPTIC TANK

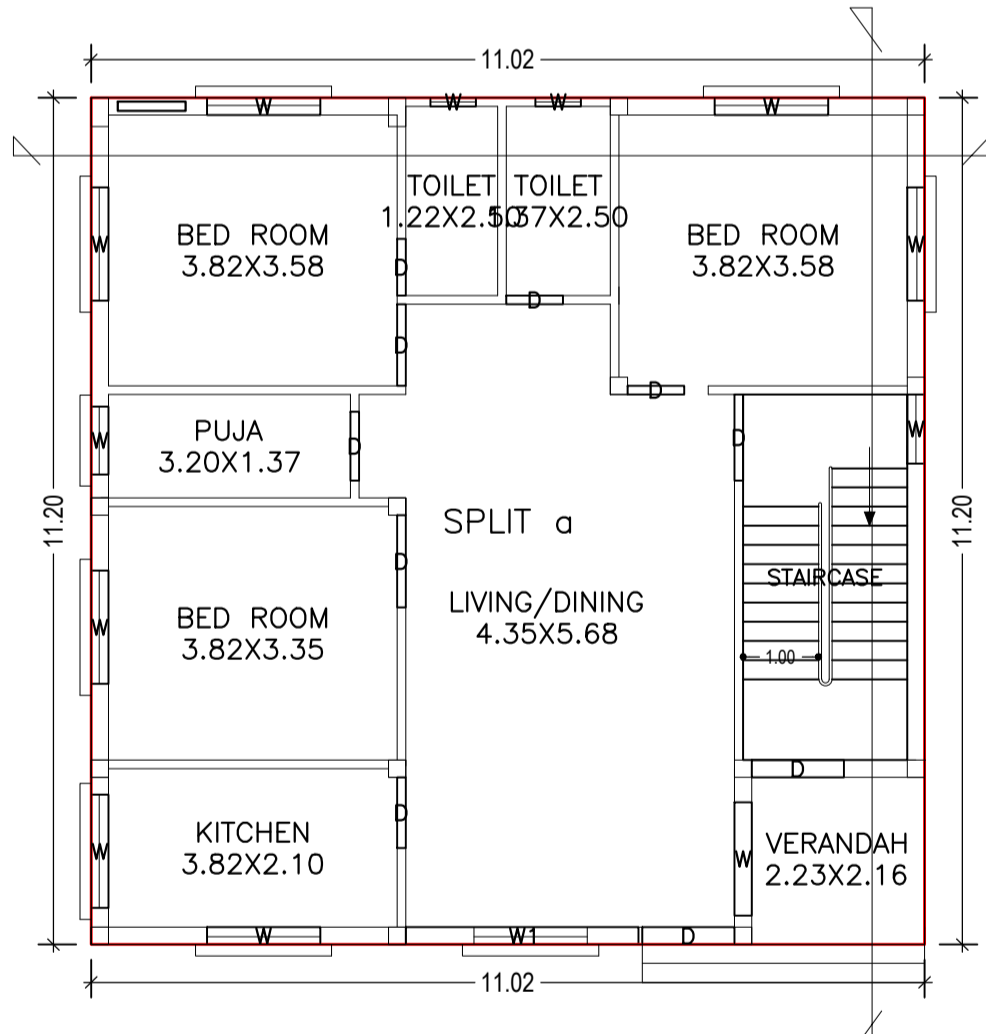

GROUND FLOOR PLAN (Proposed) (SCALE 1:100)

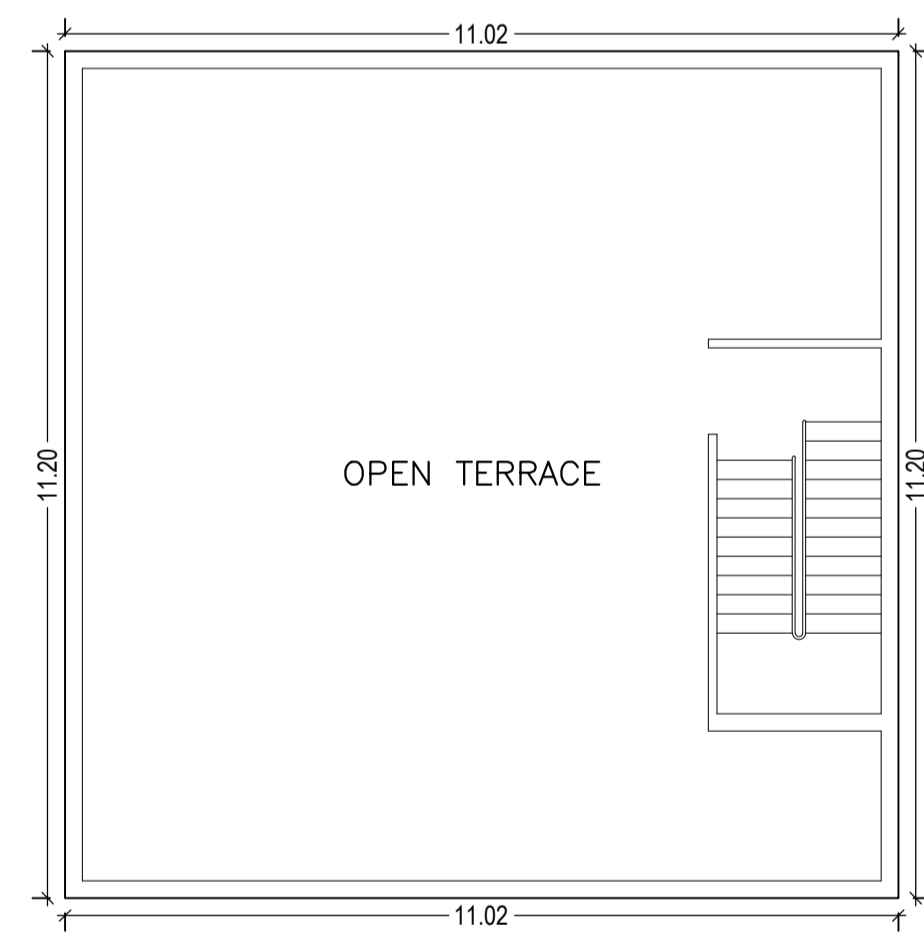

TERRACE FLOOR PLAN (SCALE 1:100)

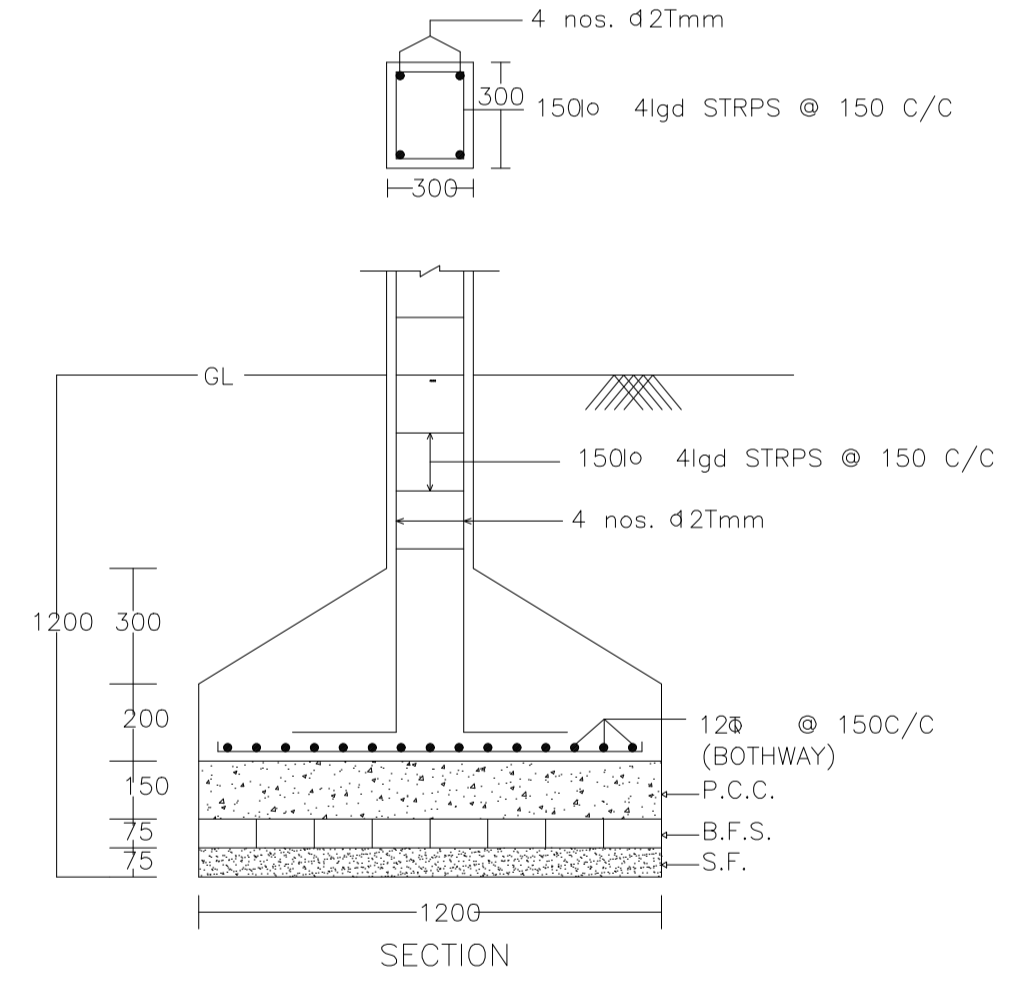

SECTION

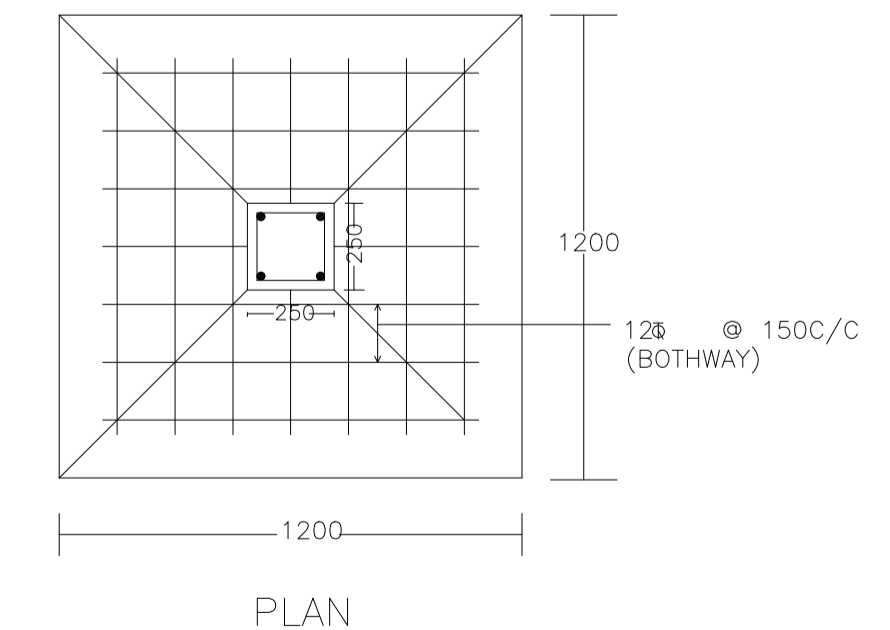

PLAN

DETAIL OF COLUMNS

SCHEDULE OF DOOR:

BUILDING NAME	NAME	LENGTH	HEIGHT	NOS
A (A)	D	0.75	2.10	03
A (A)	D	0.91	2.10	01
A (A)	D	0.93	2.10	01
A (A)	D	1.08	2.10	01
A (A)	D	1.14	2.10	01
A (A)	D	1.22	2.10	03

SCHEDULE OF WINDOW/VENTILATION:

BUILDING NAME	NAME	LENGTH	HEIGHT	NOS
A (A)	W	0.60	1.20	02
A (A)	W	0.90	1.20	01
A (A)	W	0.91	1.20	01
A (A)	W	1.50	1.20	08
A (A)	W1	3.08	1.20	01

Building :A (A)

Floor Name	Total Built Up Area (Sq.mt.)	Proposed FAR Area (Sq.mt.) Res.	Total FAR Area (Sq.mt.)	Total Consumed Additional FAR Area (Sq.mt.)	Tnmt (No.)
Ground Floor	123.48	123.48	123.48	123.48	01
Terrace Floor	0.00	0.00	0.00	0.00	00
Total:	123.48	123.48	123.48	123.48	01
Total Number of Same Buildings :	1				
Total :	123.48	123.48	123.48	123.48	01

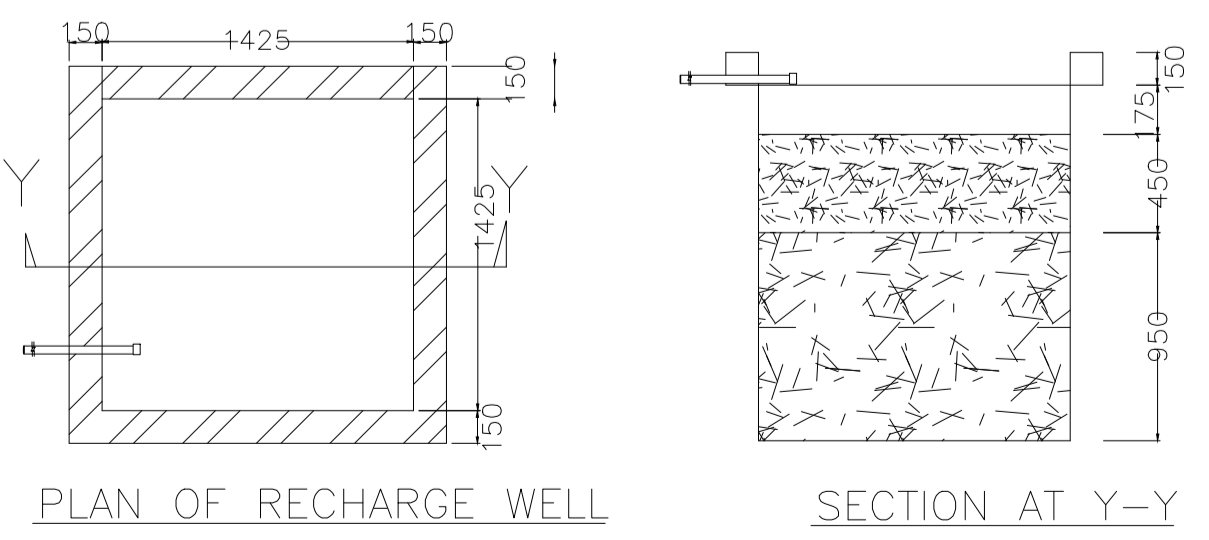

PLAN OF RECHARGE WELL

SECTION AT Y-Y

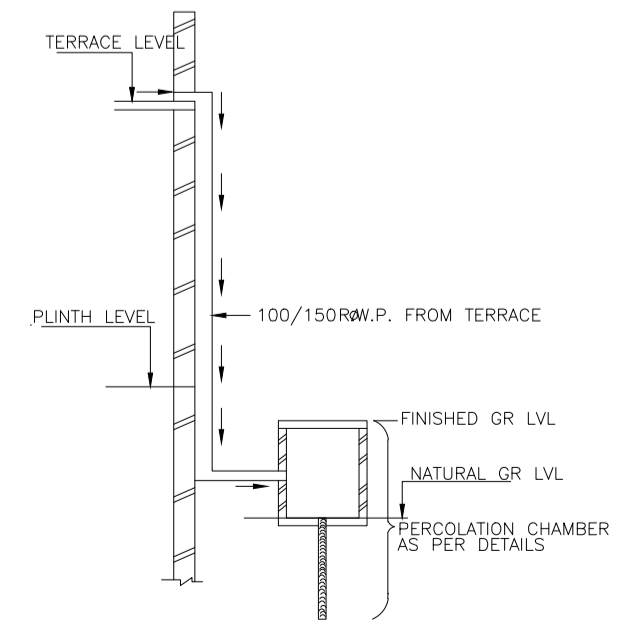

ROOF TOP RAIN WATER COLLECTION SYSTEM

Buildingwise Floor FAR Details

Floor Name	Building Name A (A)		Total	
	Proposed Built Up Area (Sq.mt.)	Proposed FAR Area (Sq.mt.)	Total Proposed Built Up Area (Sq.mt.)	Total FAR Area (Sq.mt.)
Ground Floor	123.48	123.48	123.48	123.48
Terrace Floor	0.00	0.00	0.00	0.00
Total :	123.48	123.48	123.48	123.48

Building USE/SUBUSE Details

Building Name	Building Use	Building SubUse	Building Structure
A (A)	Residential	Bungalow/ Dwelling / Non Apartment	Non-Highrise

FAR & Tenement Details (Table 4c-1)

Building	No. of Same Bldg	Total Built Up Area (Sq.mt.)	Proposed FAR Area (Sq.mt.) Res.	Total FAR Area (Sq.mt.)	Total Consumed Additional FAR Area (Sq.mt.)	Tnmt (No.)
A (A)	1	123.48	123.48	123.48	123.48	01
Grand Total :	1	123.48	123.48	123.48	123.48	01

UnitBUA Table for Building :A (A)

FLOOR	Name	UnitBUA Type	UnitBUA Area	Carpent Area	No. of Rooms	No. of Tenement
GROUND FLOOR PLAN	SPLIT a	FLAT	123.48	123.37	9	1
Total:	-	-	123.48	123.37	9	1

LTP NAME AND SIGNATURE	STRUCTURAL ENG'S NAME AND SIGNATURE	BUILDER NAME AND SIGNATURE	DIGITAL SIGNATURE
PARTHA - PAL DMC/ENG/0021/2016			