

Proposal Basic Information

Proposal File No.	DMC/BP/0185/W30/2020
Owner Name	Smt Kunti devi
Khata No	44
Plot No	398
Village Name	Manaitand
Use	Residential
SubUse	Bungalow/ Dwelling / Non Apartment

COLOR INDEX

PLOT BOUNDARY	Black
ABUTTING ROAD	Green
PROPOSED CONSTRUCTION	Red
COMMON PLOT	Yellow
ROAD WIDENING AREA	Blue
EXISTING (To be retained)	Orange
EXISTING (To be demolished)	Light Blue

AREA STATEMENT

DHANBAD MUNICIPAL CORPORATION	VERSION NO: 1.0.49
	VERSION DATE: 22/06/2020
PROJECT DETAIL:	
Region: JHARKHAND URBAN LOCAL BODIES	Plot Use: Residential
District: DHANBAD	Plot SubUse: Bungalow/ Dwelling / Non Apartment
Authority: DHANBAD MUNICIPAL CORPORATION	PlotNearbyReligiousStructure: NA
Inward_No: DMC/BP/0185/W30/2020	PlotSubPlot No: 398
Application Type: General Proposal	North: Plot No. - PART OF PLOT NO - 398
Project Type: Building Permission	South: Plot No. - HOUSE OF JALDHAR SINGH
Nature of Development: New	East: Plot No. - PART OF PLOT NO - 398
Location of Development Area: Old Area	West: Road Width - 4.57 M WIDE ROAD
AREA DETAILS:	SQ.MT.
AREA OF PLOT (Minimum)	214.94
NET AREA OF PLOT(Gross Plot Area - Deduction from Gross Plot area)	214.94
Deduction for Balance Plot Area(from Gross Plot Area)	13.39
Common Plot	13.39
BALANCE AREA OF PLOT(Net Plot Area - Recreational/Amenity space)	201.56
PLOT AREA FOR COVERAGE(Net Plot Area)	214.94
Plot Area for FAR (Net Plot Area + Road/Widening Area)	214.94
COVERAGE CHECK	
Permissible Coverage area (70.00 %)	150.46
Proposed Coverage Area (56.71 %)	121.90
Total Prop. Coverage Area (56.71 %)	121.90
Balance coverage area (13.29 %)	28.56
FAR CHECK	
Perm. FAR Area (1.50)	322.41
Total Perm. FAR area	322.41
Residential FAR	249.66
Proposed FAR Area	249.66
Total Proposed FAR Area	249.66
Consumed FAR (Factor)	1.16
Balance FAR Area	72.75
BUILT UP AREA CHECK	
Total Proposed BuiltUp Area	249.66
ARCHITECT (Regd)	KUMARI RINKU RANI
ENGINEER (Regd)	
SUPERVISOR (Regd)	
OWNER (Regd)	Smt Kunti devi
Buildingwise Development Details	LOCAL BODY

UnitBUA Table for Building :A (A)

FLOOR	Name	UnitBUA Type	UnitBUA Area	Carpet Area	No. of Rooms	No. of Tenement
FIRST FLOOR PLAN	SPLIT A	FLAT	0.00	0.00	8	0
GROUND FLOOR PLAN	SPLIT A	FLAT	249.66	249.54	8	1
Total:	-	-	249.66	249.54	16	1

Building :A (A)

Floor Name	Total Built Up Area (Sq.mt.)	Proposed FAR Area (Sq.mt.)	Total FAR Area (Sq.mt.)	Total Consumed Additional FAR Area (Sq.mt.)	Tnmt (No.)
Ground Floor	121.90	121.90	121.90	121.90	01
First Floor	127.76	127.76	127.76	127.76	00
Terrace Floor	0.00	0.00	0.00	0.00	00
Total:	249.66	249.66	249.66	249.66	01
Total Number of Same Buildings :	1				
Total :	249.66	249.66	249.66	249.66	01

SCHEDULE OF DOOR:

BUILDING NAME	NAME	LENGTH	HEIGHT	NOS
A (A)	D	0.76	2.10	04
A (A)	D	0.89	2.10	01
A (A)	D	0.91	2.10	02
A (A)	D	1.06	2.10	02
A (A)	D	1.07	2.10	04
A (A)	D	1.23	2.10	02
A (A)	D	1.35	2.10	01

SCHEDULE OF WINDOW/VENTILATION:

BUILDING NAME	NAME	LENGTH	HEIGHT	NOS
A (A)	W	0.61	1.20	08
A (A)	W	0.91	1.20	04
A (A)	W	0.95	1.20	01
A (A)	W	1.22	1.20	02
A (A)	W	1.52	1.20	06
A (A)	W	2.01	1.20	01
A (A)	W	2.36	1.20	01
A (A)	W	2.88	1.20	01

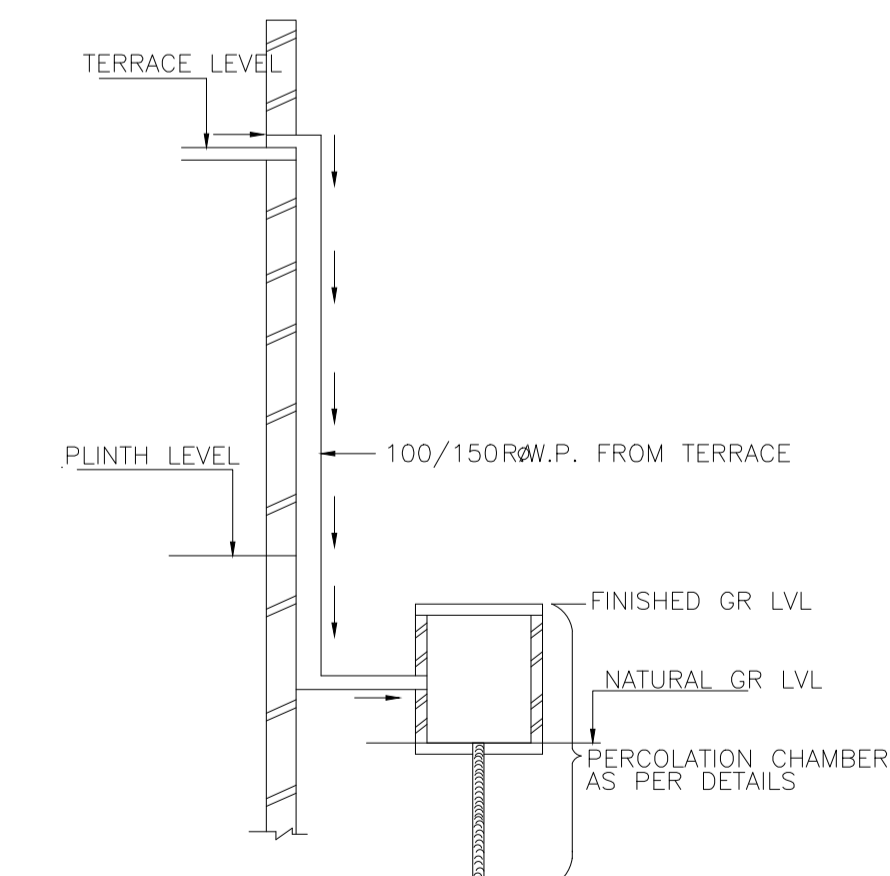
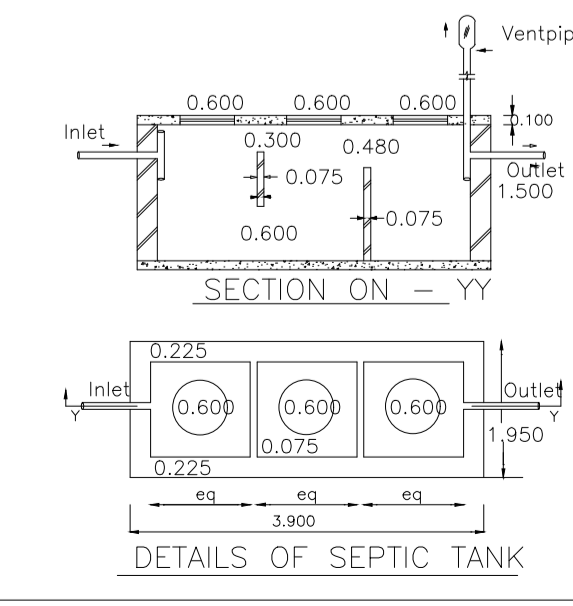
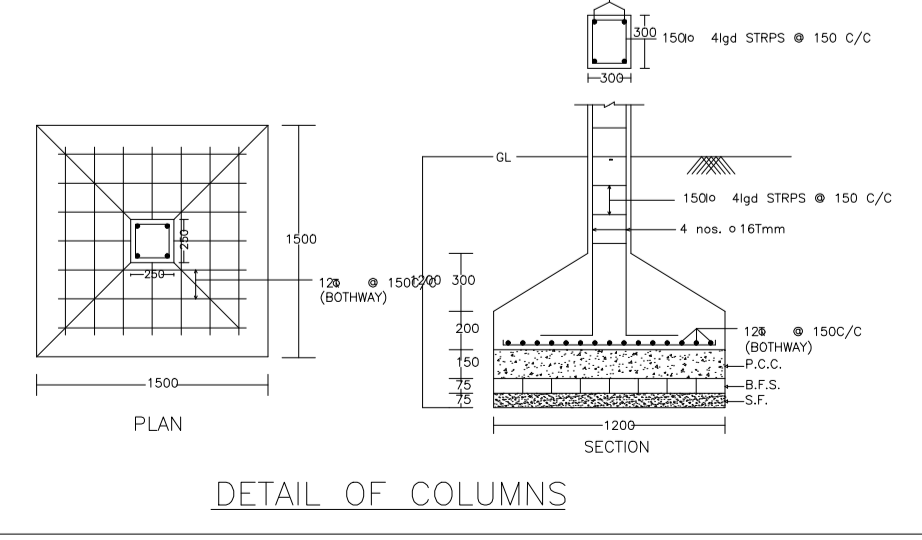
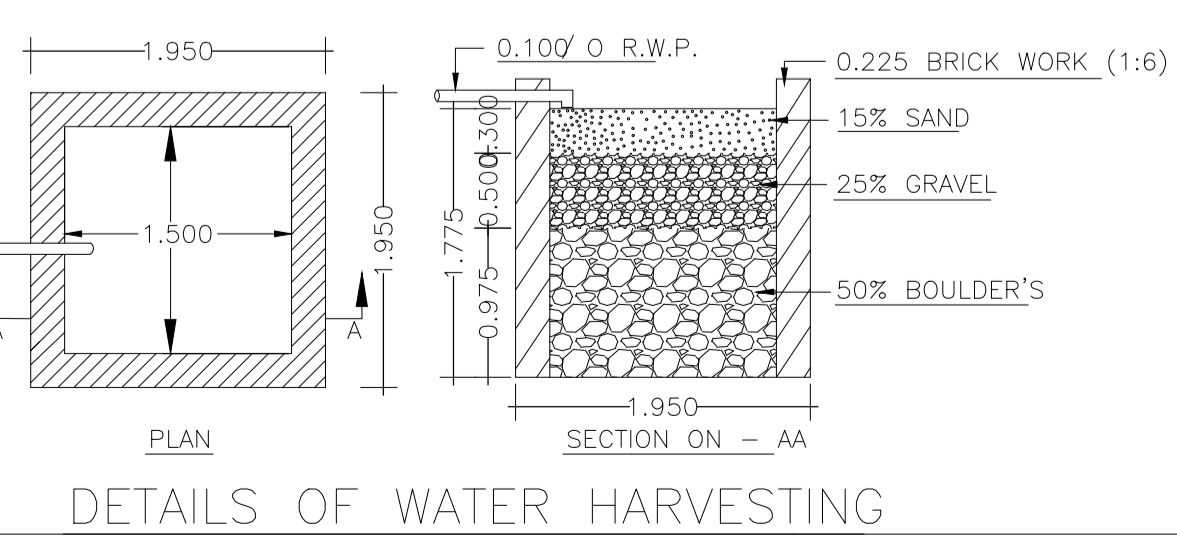
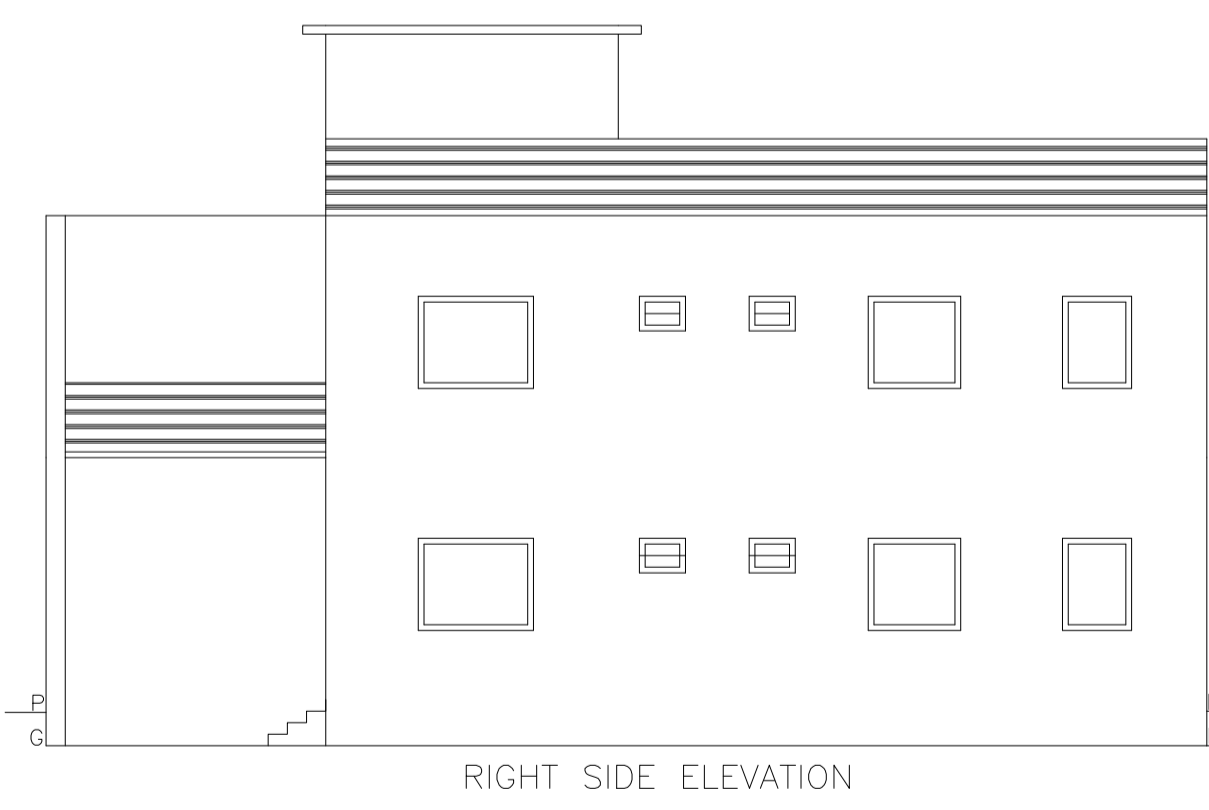
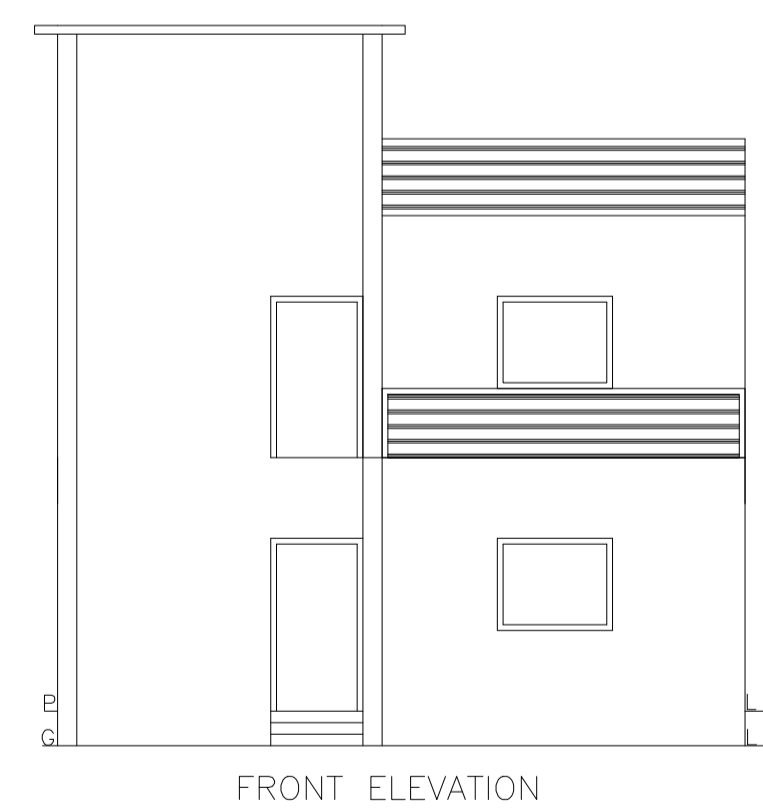

Building USE/SUBUSE Details

Building Name	Building Use	Building SubUse	Building Structure
A (A)	Residential	Bungalow/ Dwelling / Non Apartment	Non-Highrise

FAR & Tenement Details (Table 4c-1)

Building	No. of Same Bldg	Total Built Up Area (Sq.mt.)	Proposed FAR Area (Sq.mt.)	Total FAR Area (Sq.mt.)	Total Consumed Additional FAR Area (Sq.mt.)	Tnmt (No.)
A (A)	1	249.66	249.66	249.66	249.66	01
Grand Total :	1	249.66	249.66	249.66	249.66	01

LTP NAME AND SIGNATURE	STRUCTURAL ENG'S NAME AND SIGNATURE	BUILDER NAME AND SIGNATURE	DIGITAL SIGNATURE
KUMARI RINKU RANI DMC/ENG/00162016			