

DETAIL OF COLUMNS

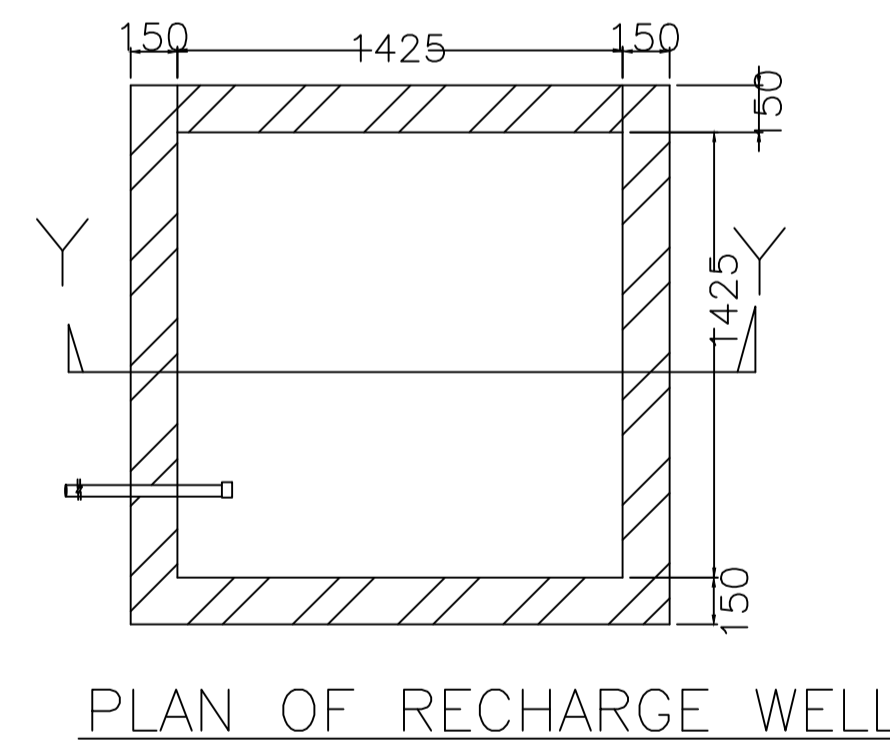

WATER HARVESTING

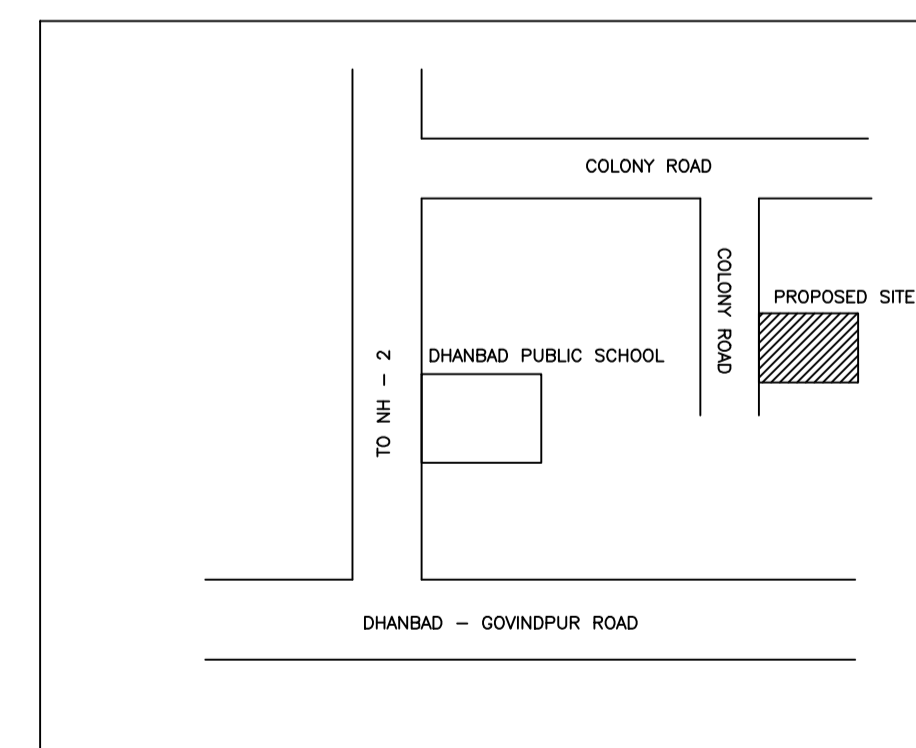

FAR & Tenement Details (Table 4c-1)

Building	No. of Same Bldg	Total Built Up Area (Sq.mt.)	Proposed FAR Area (Sq.mt.)	Total FAR Area (Sq.mt.)	Total Consumed Additional FAR Area (Sq.mt.)	Tnmt (No.)
A (BUILDING)	1	244.20	244.20	244.20	244.20	01
Grand Total :	1	244.20	244.20	244.20	244.20	01

Proposal Basic Information

Proposal File No.	DMC/BP/0207/W22/2020
Owner Name	LALITA KUMARI.
Khata No	87 ( Old ), 249 ( New )
Plot No	716(old), 820(new)
Village Name	Bhelaland
Use	Residential
SubUse	Bungalow/ Dwelling / Non Apartment

AREA STATEMENT DHANBAD MUNICIPAL CORPORATION	VERSION NO. : 1.0.50	SQ.MT.
PROJECT DETAIL:	VERSION DATE: 16/10/2020	
Region: JHARKHAND URBAN LOCAL BODIES	Plot Use: Residential	
District: DHANBAD	Plot SubUse: Bungalow/ Dwelling / Non Apartment	
Authority: DHANBAD MUNICIPAL CORPORATION	PlotNearbyReligiousStructure: NA	
Inward No: DMC/BP/0207/W22/2020	PlotSubPlot No: 716(old), 820(new)	
Application Type: General Proposal	North: Plot No. - PLOT NO 716	
Project Type: Building Permission	South: Plot No. - YAMUNA PANDEY	
Nature of Development: New	East: Road Width - 4.87	
Location of Development Area: Old Area	West: Plot No. - RANJIT SINGH	
AREA OF PLOT (Minimum)	(A)	163.17
NET AREA OF PLOT(Gross Plot Area - Deduction from Gross Plot area)	(A-Deductions)	163.17
Deduction for Balance Plot Area(from Gross Plot Area)		
Common Plot		25.27
Total		25.27
BALANCE AREA OF PLOT(Net Plot Area - Recreational/Amenity space)	(A-Deductions)	137.90
PLOT AREA FOR COVERAGE(Net Plot Area)	(A-Deductions)	163.17
Plot Area for FAR (Net Plot Area + RoadWidening Area)	(A-Deductions)	163.17
COVERAGE CHECK		
Permissible Coverage area ( 70.00 % )		114.22
Proposed Coverage Area ( 49.89 % )		81.40
Total Prop. Coverage Area ( 49.89 % )		81.40
Balance coverage area ( 20.11 % )		32.82
FAR CHECK		
Perm. FAR Area ( 1.50 )		244.76
Total Perm. FAR area		244.76
Residential FAR		244.19
Proposed FAR Area		244.19
Total Proposed FAR Area		244.19
Consumed FAR (Factor)		1.50
Balance FAR Area		0.57
BUILT UP AREA CHECK		
Total Proposed BuiltUp Area		244.20
ARCHITECT (Regd)	PARTHA - PAL	
ENGINEER (Regd)		
SUPERVISOR (Regd)		
OWNER (Regd)	LALITA KUMARI	
DEVELOPMENT AUTHORITY		LOCAL BODY

COLOR INDEX	
PLOT BOUNDARY	Black
ABUTTING ROAD	Green
PROPOSED CONSTRUCTION	Red
COMMON PLOT	Yellow
ROAD WIDENING AREA	Orange
EXISTING (To be retained)	Blue
EXISTING (To be demolished)	Light Blue

Buildingwise Floor FAR Details

Floor Name	Building Name A (BUILDING)		Total	
	Proposed Built Up Area (Sq.mt.)	Proposed FAR Area (Sq.mt.)	Total Proposed Built Up Area (Sq.mt.)	Total FAR Area (Sq.mt.)
Ground Floor	81.40	81.40	81.40	81.40
First Floor	81.40	81.40	81.40	81.40
Second Floor	81.40	81.40	81.40	81.40
Terrace Floor	0.00	0.00	0.00	0.00
Total :	244.20	244.20	244.20	244.20

Building USE/SUBUSE Details

Building Name	Building Use	Building SubUse	Building Structure
A (BUILDING)	Residential	Bungalow/ Dwelling / Non Apartment	Non-Highrise

LTP NAME AND SIGNATURE	STRUCTURAL ENG'S NAME AND SIGNATURE	BUILDER NAME AND SIGNATURE	DIGITAL SIGNATURE
PARTHA - PAL DMC/ENG/0021/2016			

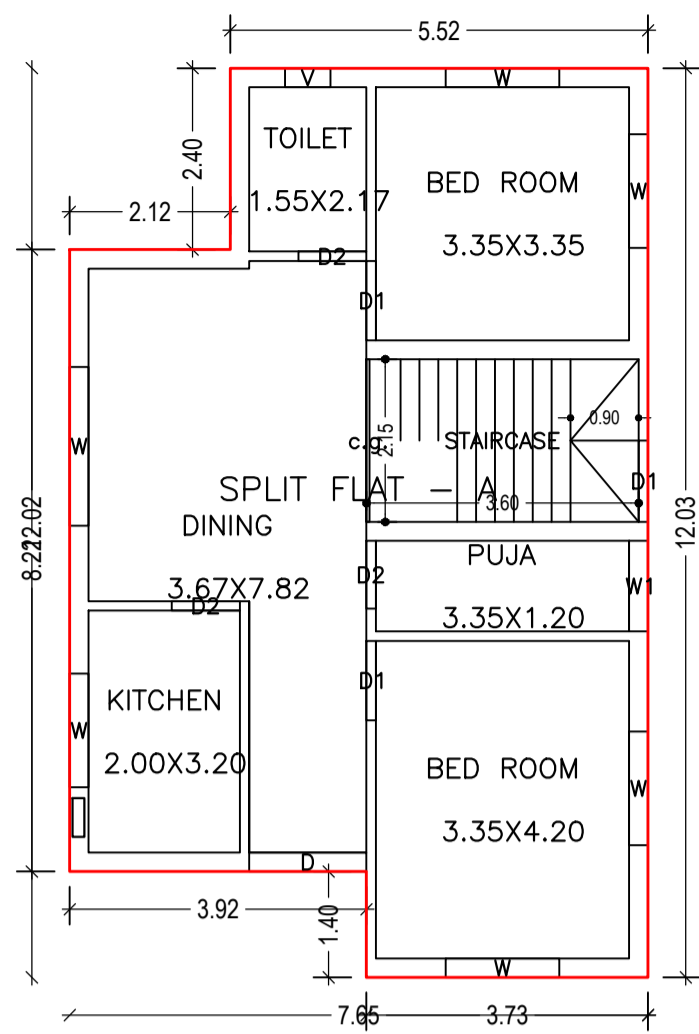

GROUND FLOOR PLAN (Proposed) (SCALE 1:100)

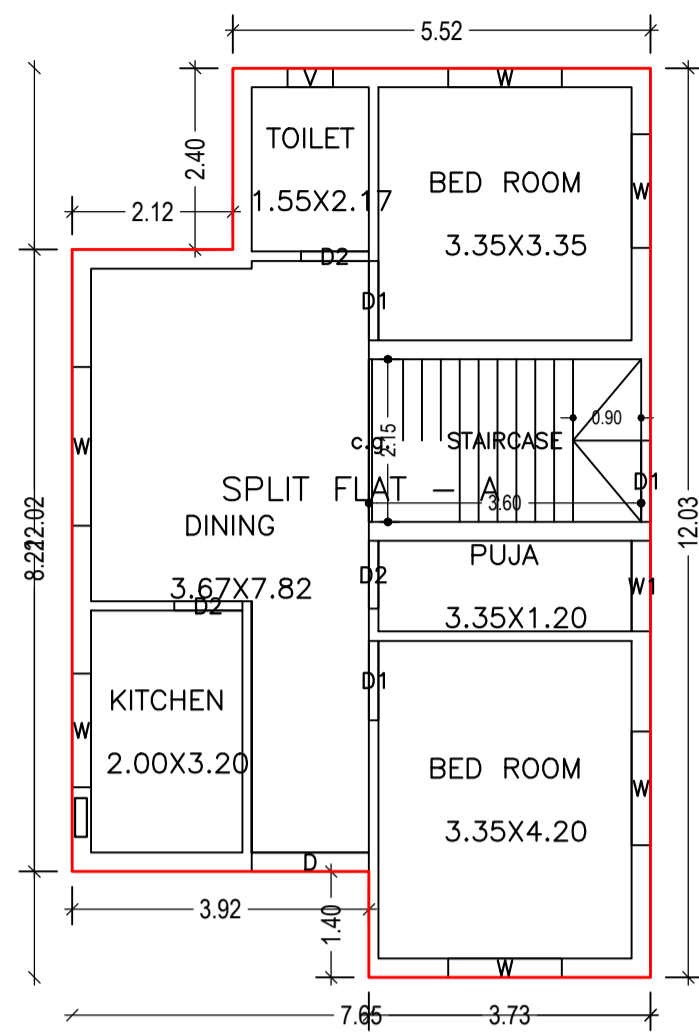

FIRST FLOOR PLAN (Proposed) (SCALE 1:100)

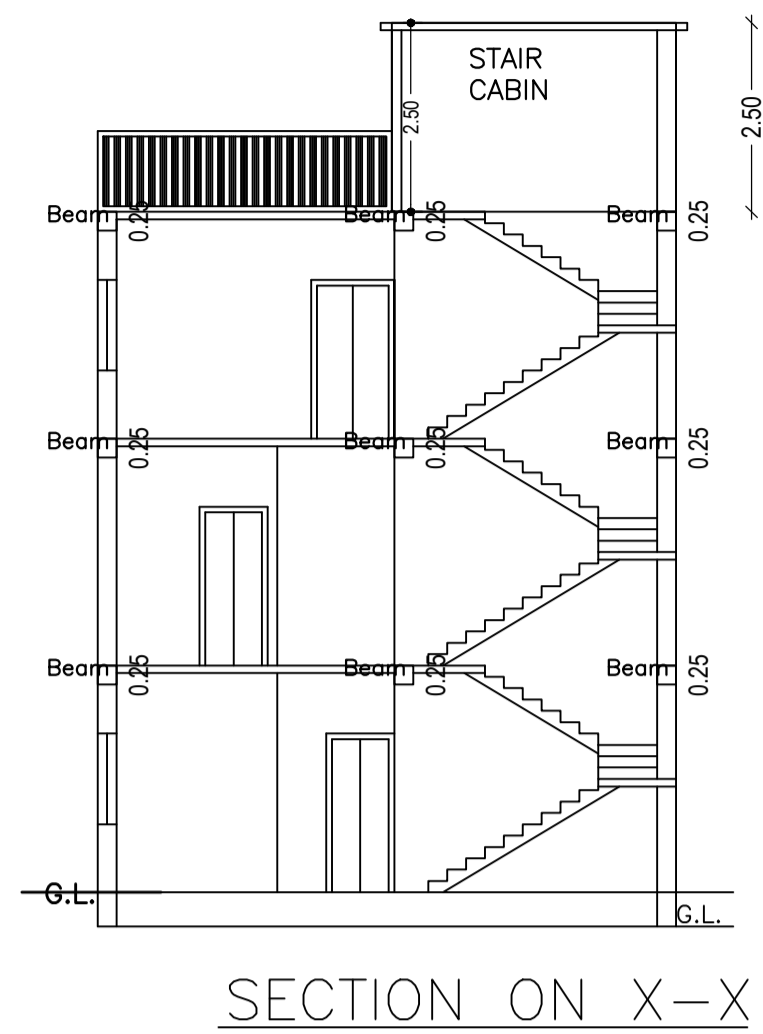

SECTION ON X-X

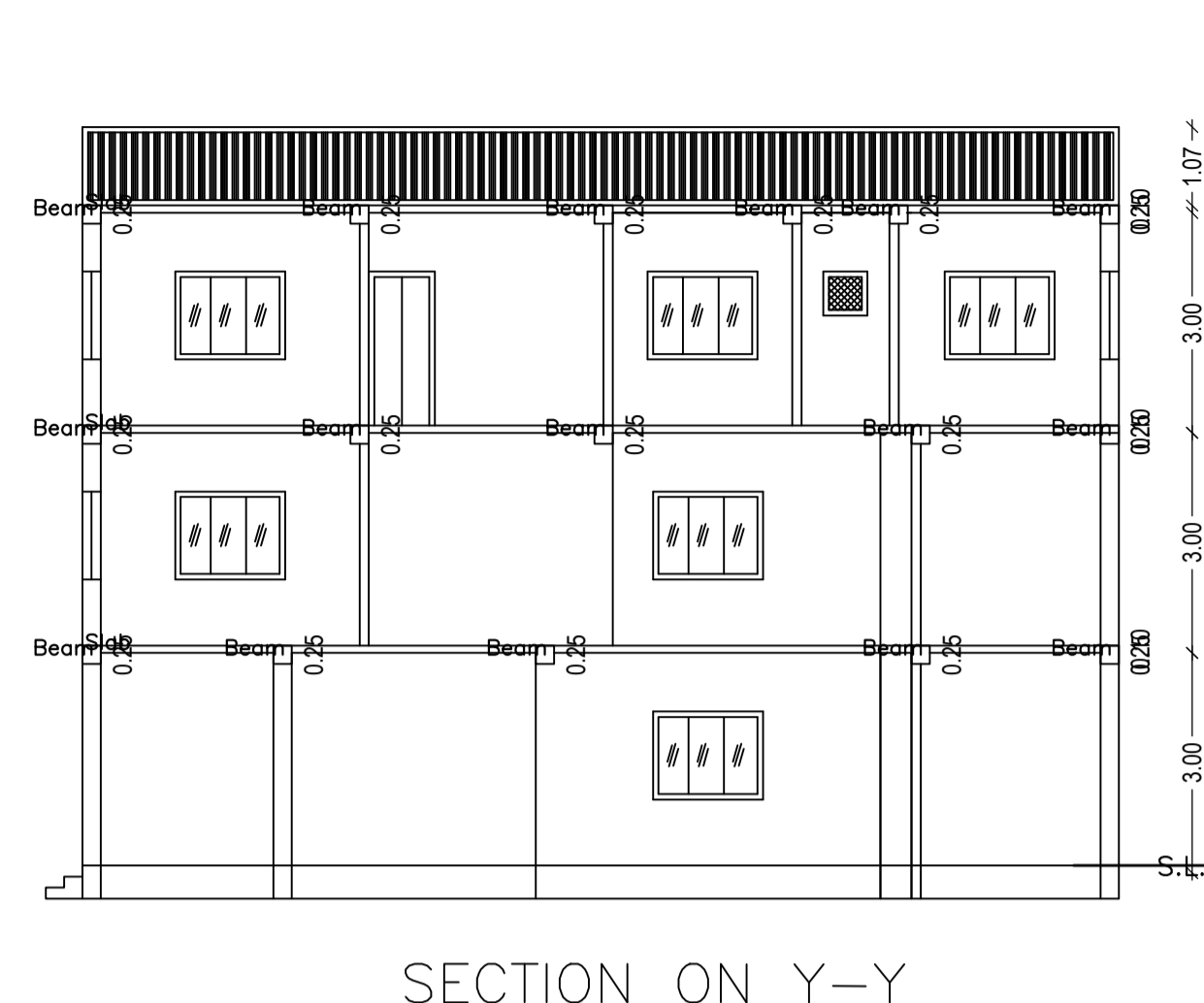

SECTION ON Y-Y

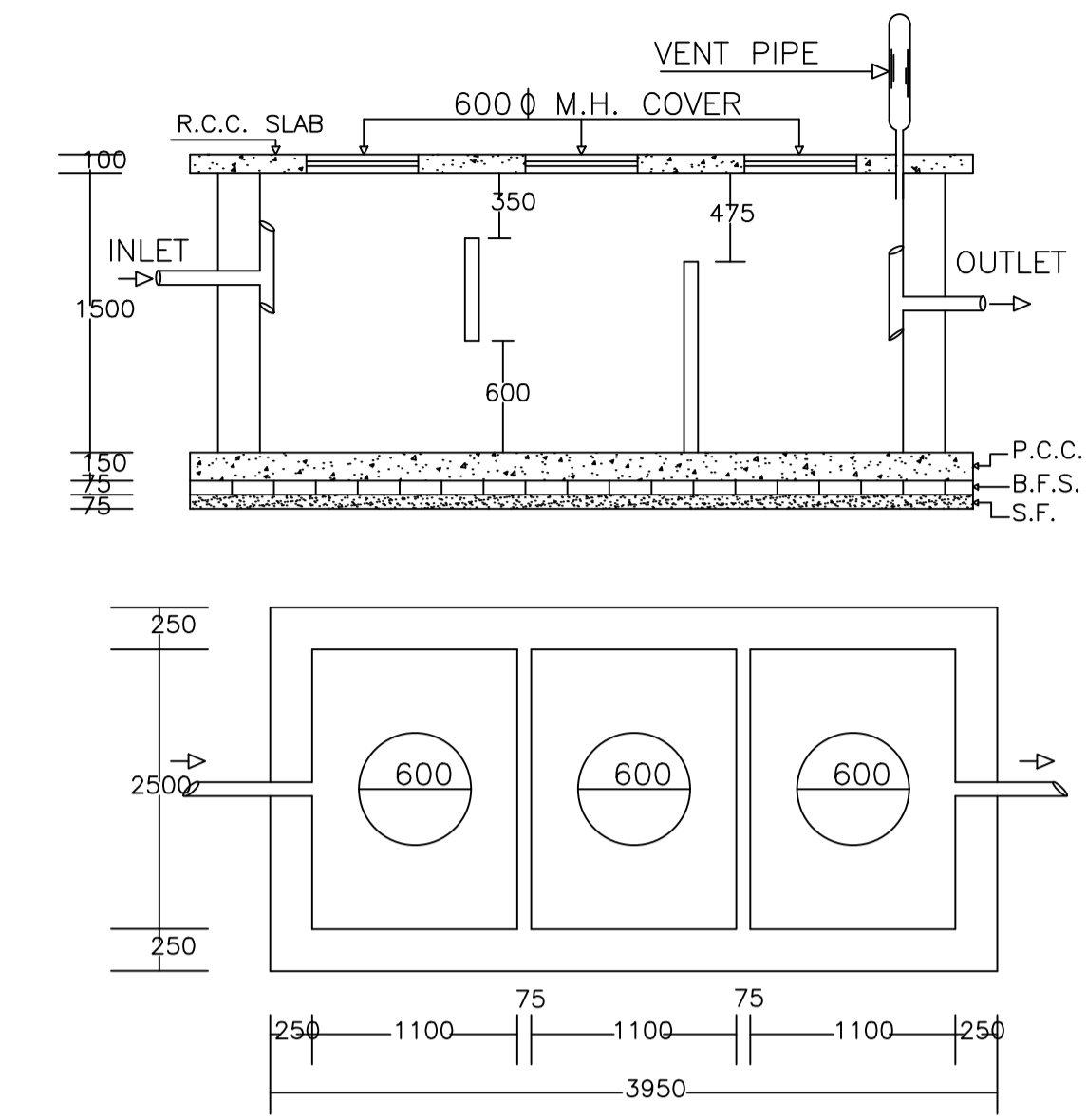

PLAN OF SEPTIC TANK

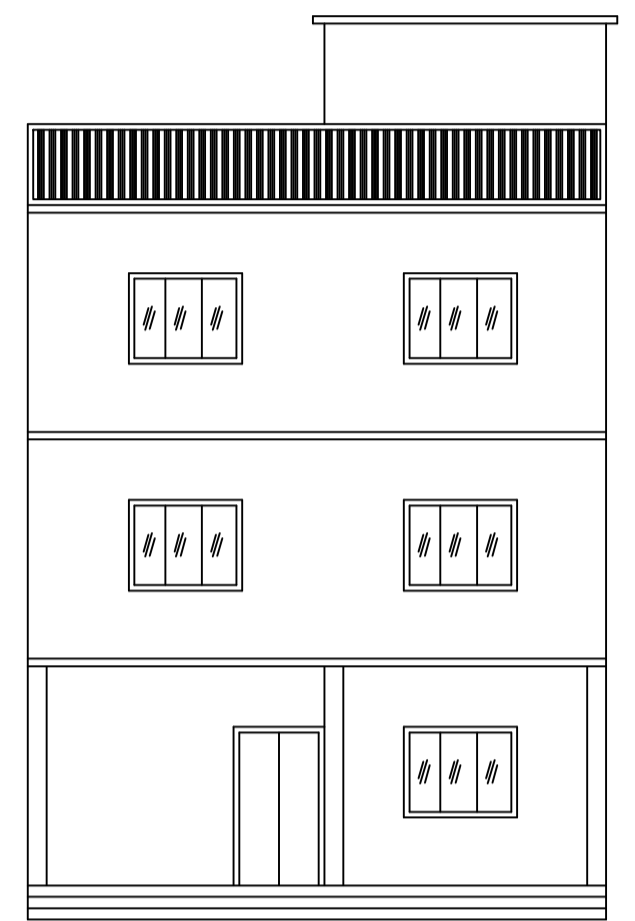

FRONT ELEVATION

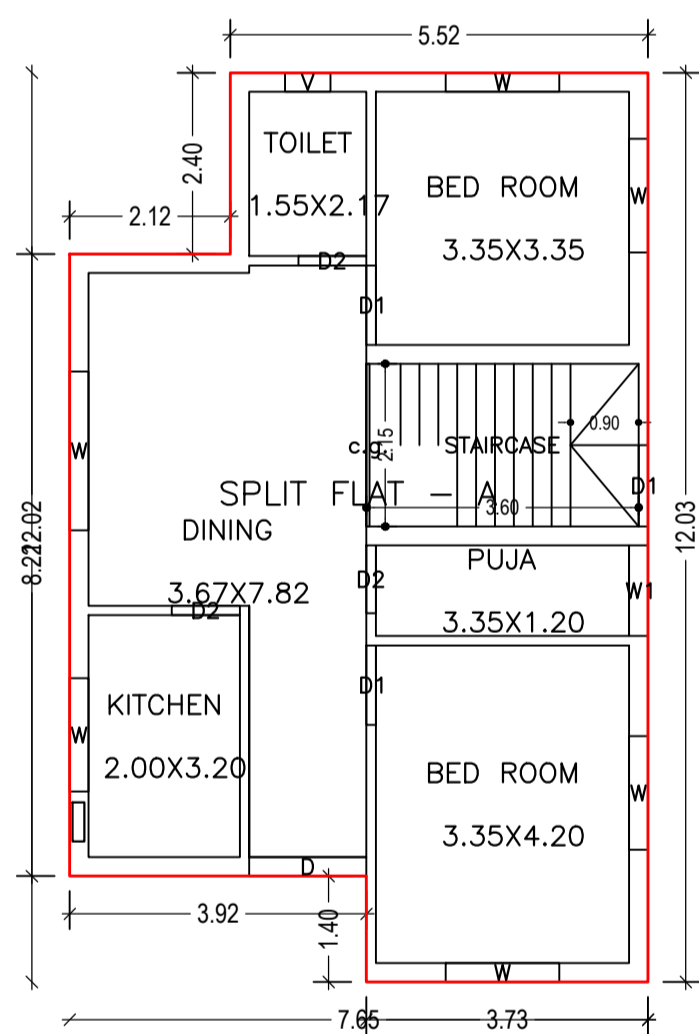

SECOND FLOOR PLAN (Proposed) (SCALE 1:100)

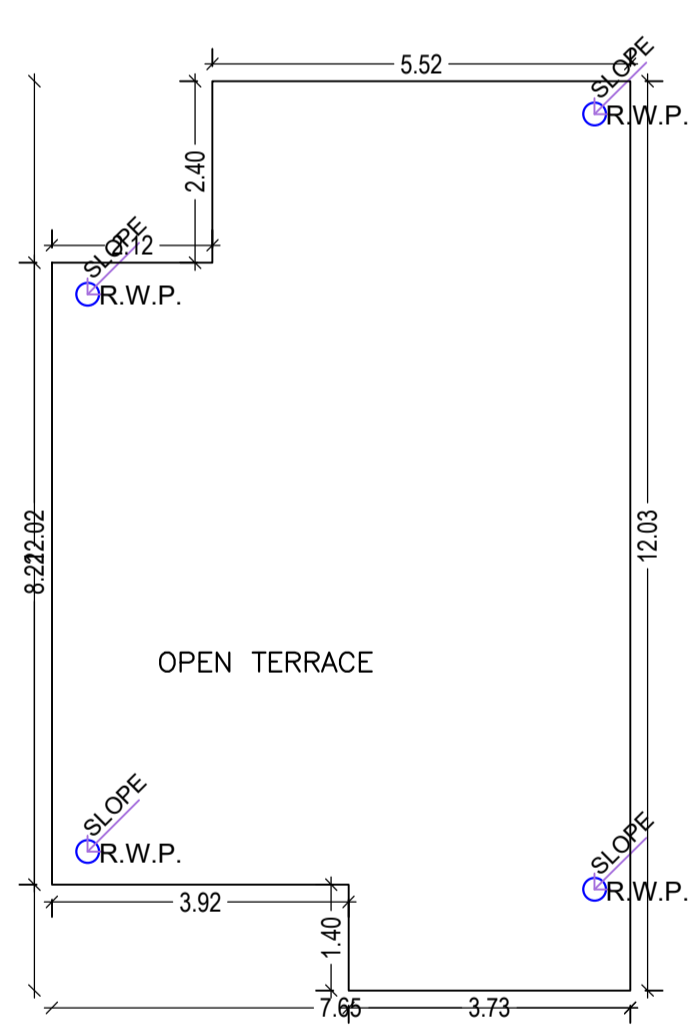

TERRACE FLOOR PLAN (SCALE 1:100)

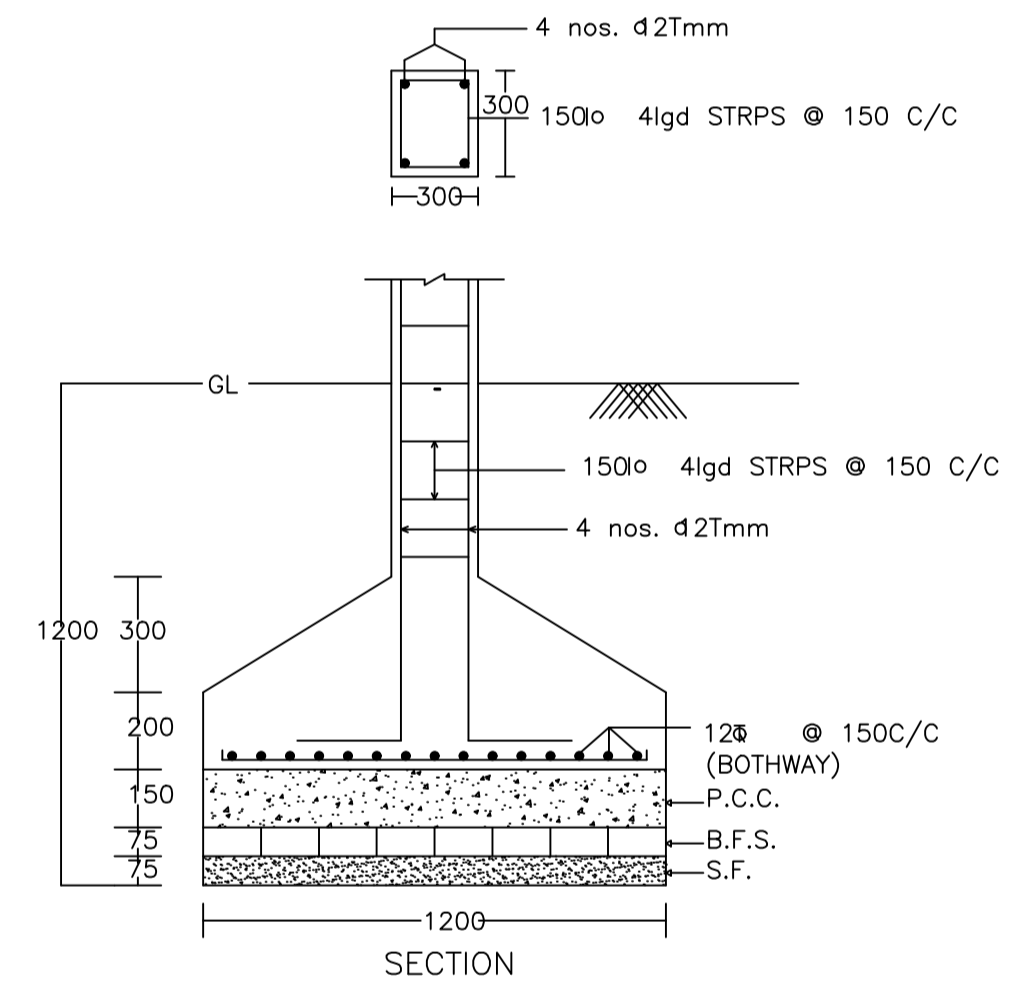
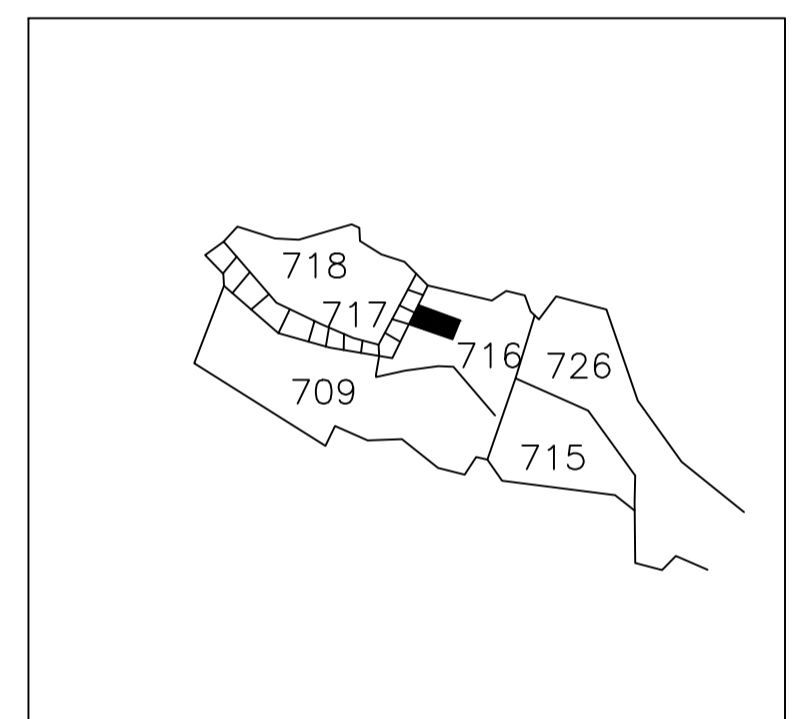

SECTION

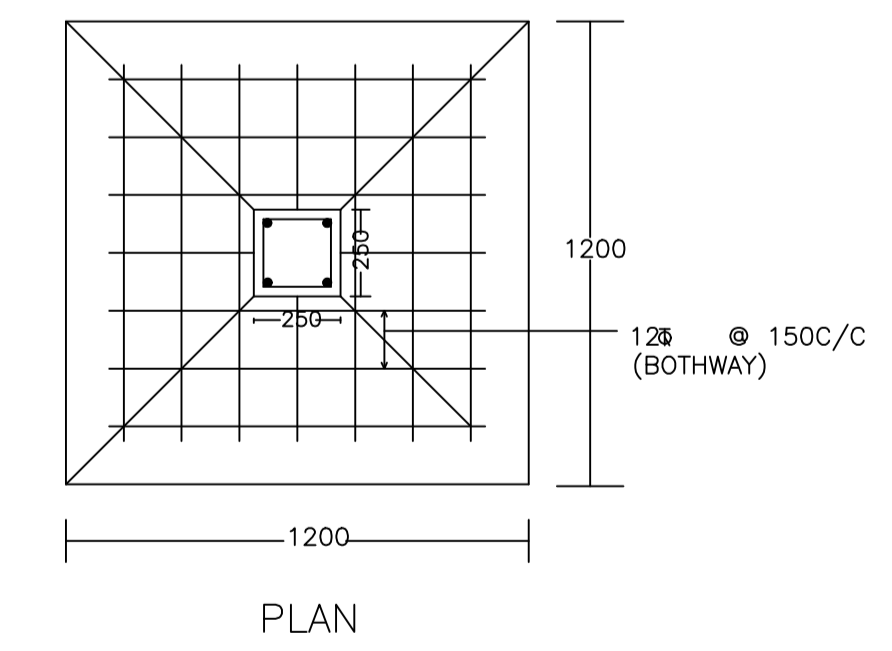

DETAIL OF COLUMNS

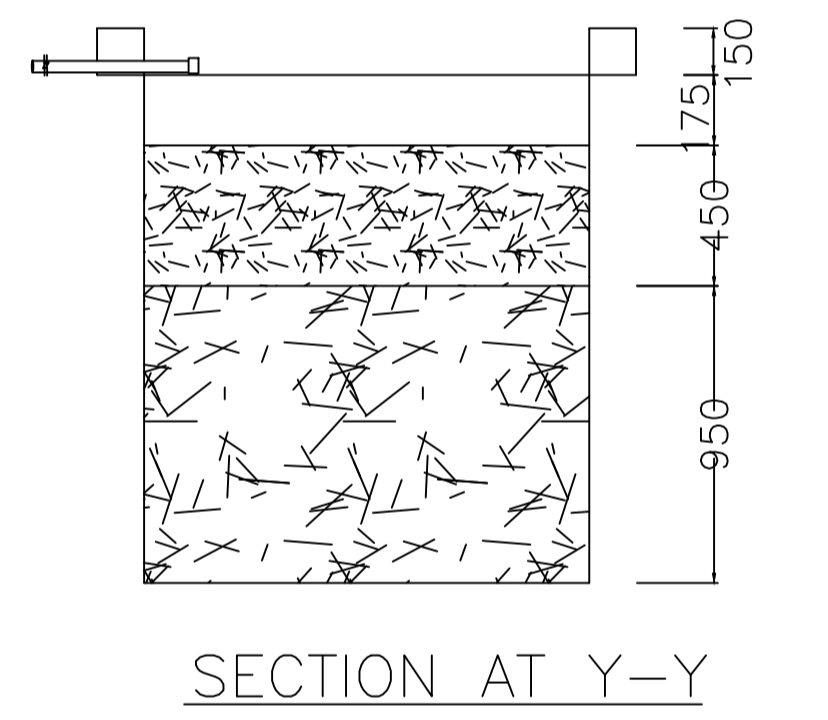

SECTION AT Y-Y

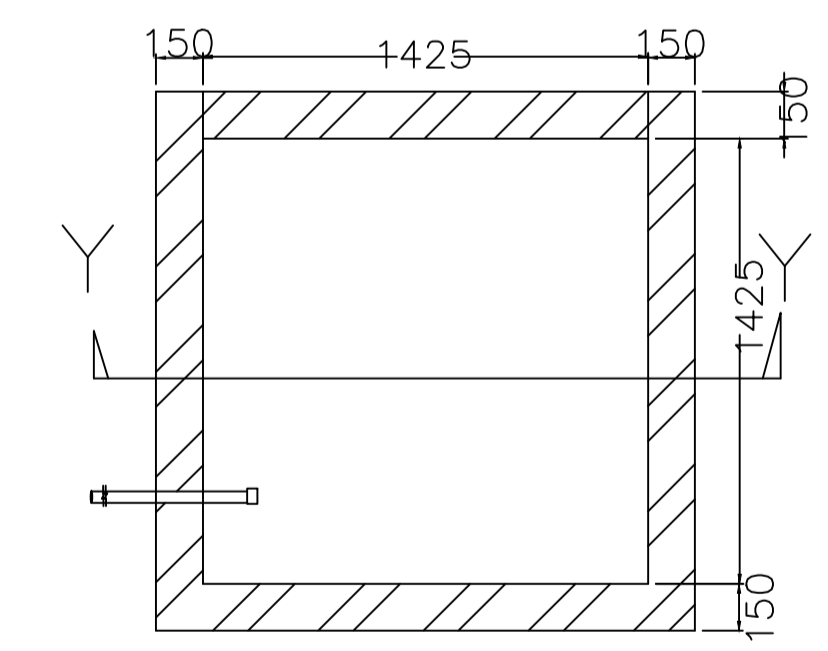

PLAN OF RECHARGE WELL

WATER HARVESTING

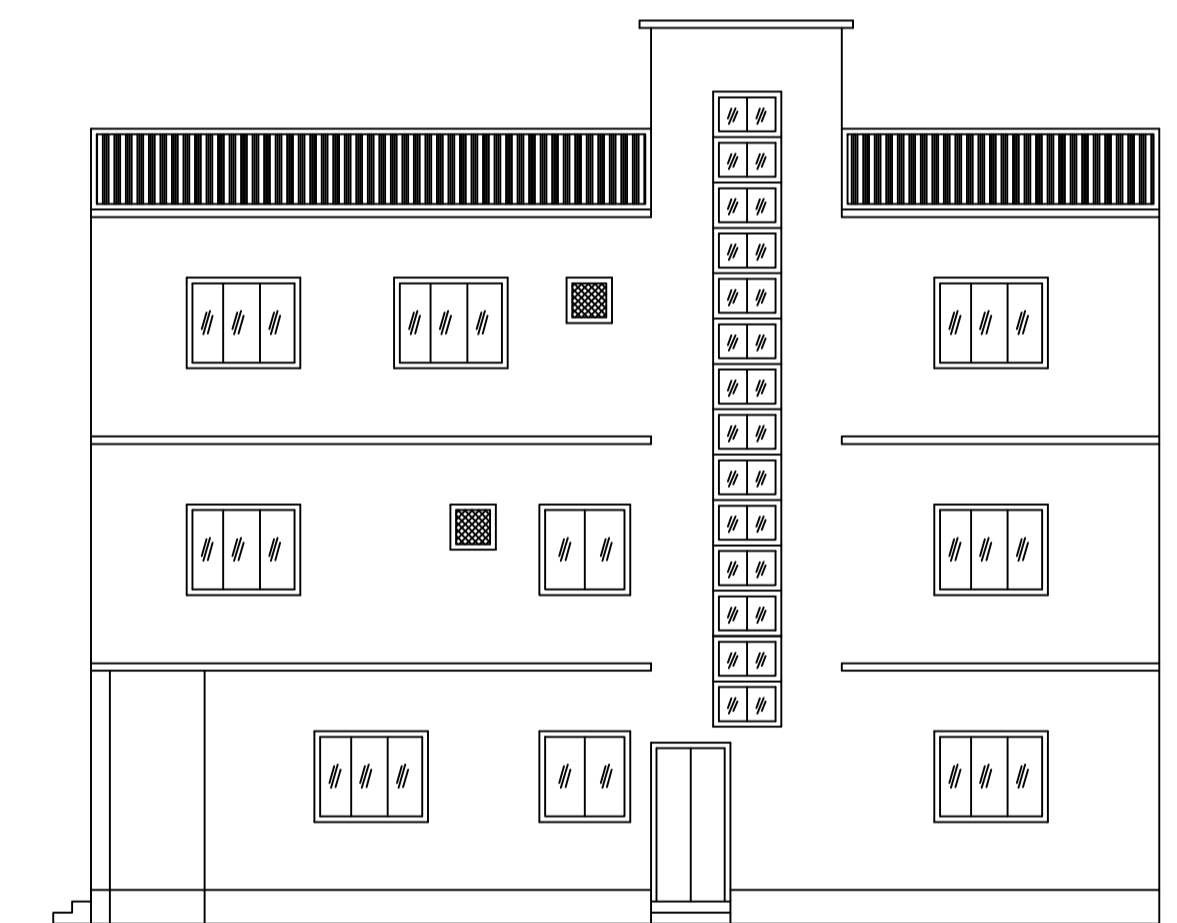

RIGHT SIDE ELEVATION

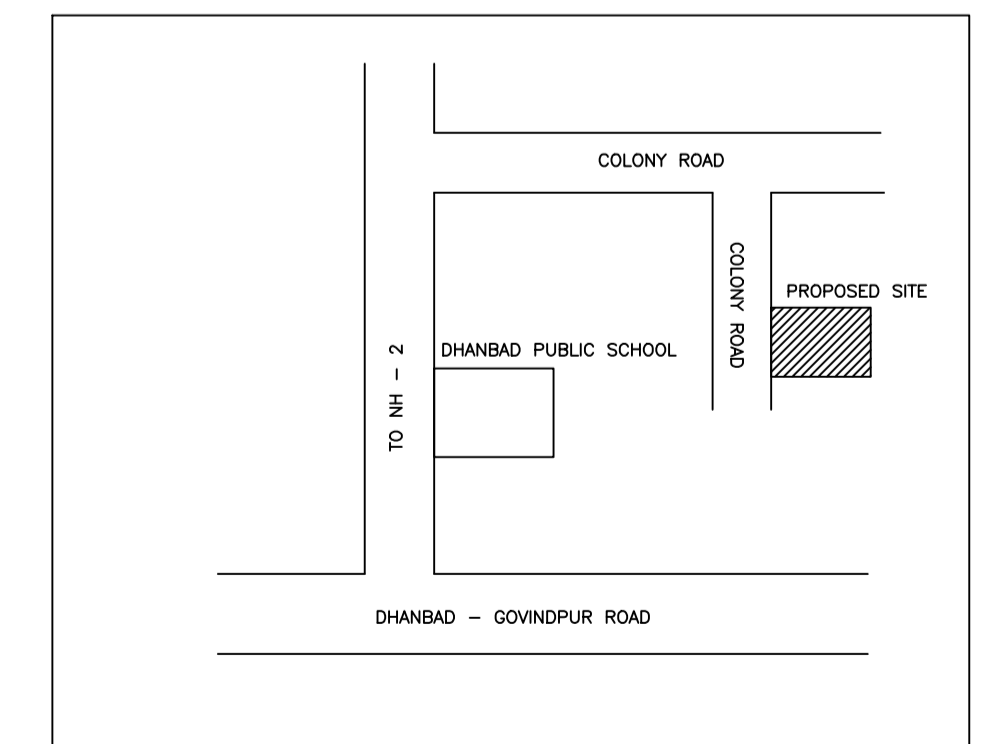

DHAMBAD - GOVINDPUR ROAD

Proposal Basic Information

Proposal File No.	DMC/BP/0207/W22/2020
Owner Name	LALITA KUMARI.
Khata No	87 ( Old ), 249 ( New )
Plot No	716(old), 820(new)
Village Name	Bhelaland
Use	Residential
SubUse	Bungalow/ Dwelling / Non Apartment

Building :A (BUILDING)

Floor Name	Total Built Up Area (Sq.mt.)	Proposed FAR Area (Sq.mt.) Resi.	Total FAR Area (Sq.mt.)	Total Consumed Additional FAR Area (Sq.mt.)	Tnmt (No.)
Ground Floor	81.40	81.40	81.40	81.40	01
First Floor	81.40	81.40	81.40	81.40	00
Second Floor	81.40	81.40	81.40	81.40	00
Terrace Floor	0.00	0.00	0.00	0.00	00
Total:	244.20	244.20	244.20	244.20	01
Total Number of Same Buildings	1				
Total:	244.20	244.20	244.20	244.20	01

SCHEDULE OF DOOR:

BUILDING NAME	NAME	LENGTH	HEIGHT	NOS
A (BUILDING)	D2	0.90	2.10	09
A (BUILDING)	D1	1.05	2.10	06
A (BUILDING)	D	1.55	2.10	03
A (BUILDING)	c.g.	2.15	2.10	03

SCHEDULE OF WINDOW/VENTILATION:

BUILDING NAME	NAME	LENGTH	HEIGHT	NOS
A (BUILDING)	V	0.60	1.20	03
A (BUILDING)	W1	1.20	1.20	03
A (BUILDING)	W	1.50	1.20	15
A (BUILDING)	W	2.10	1.20	03

UnitBUA Table for Building :A (BUILDING)

FLOOR	Name	UnitBUA Type	UnitBUA Area	Carpet Area	No. of Rooms	No. of Tenement
GROUND FLOOR PLAN	SPLIT FLAT - A	FLAT	220.16	219.92	6	1
FIRST FLOOR PLAN	SPLIT FLAT - A	FLAT	0.00	0.00	6	0
SECOND FLOOR PLAN	SPLIT FLAT - A	FLAT	0.00	0.00	6	0
Total:	-	-	220.16	219.92	18	1

LTP NAME AND SIGNATURE PARTHA - PAL DMC/ENG/0021/2016	STRUCTURAL ENG'S NAME AND SIGNATURE	BUILDER NAME AND SIGNATURE	DIGITAL SIGNATURE
---	-------------------------------------	----------------------------	-------------------