

Proposal Basic Information	
Proposal File No.	DMC/BP/0205/W20/2020
Owner Name	REKHA DEVI
Khata No	63(old),387(new)
Plot No	238(OLD),268(NEW)
Village Name	Panderpala
Use	Residential
SubUse	Bungalow/ Dwelling / Non Apartment

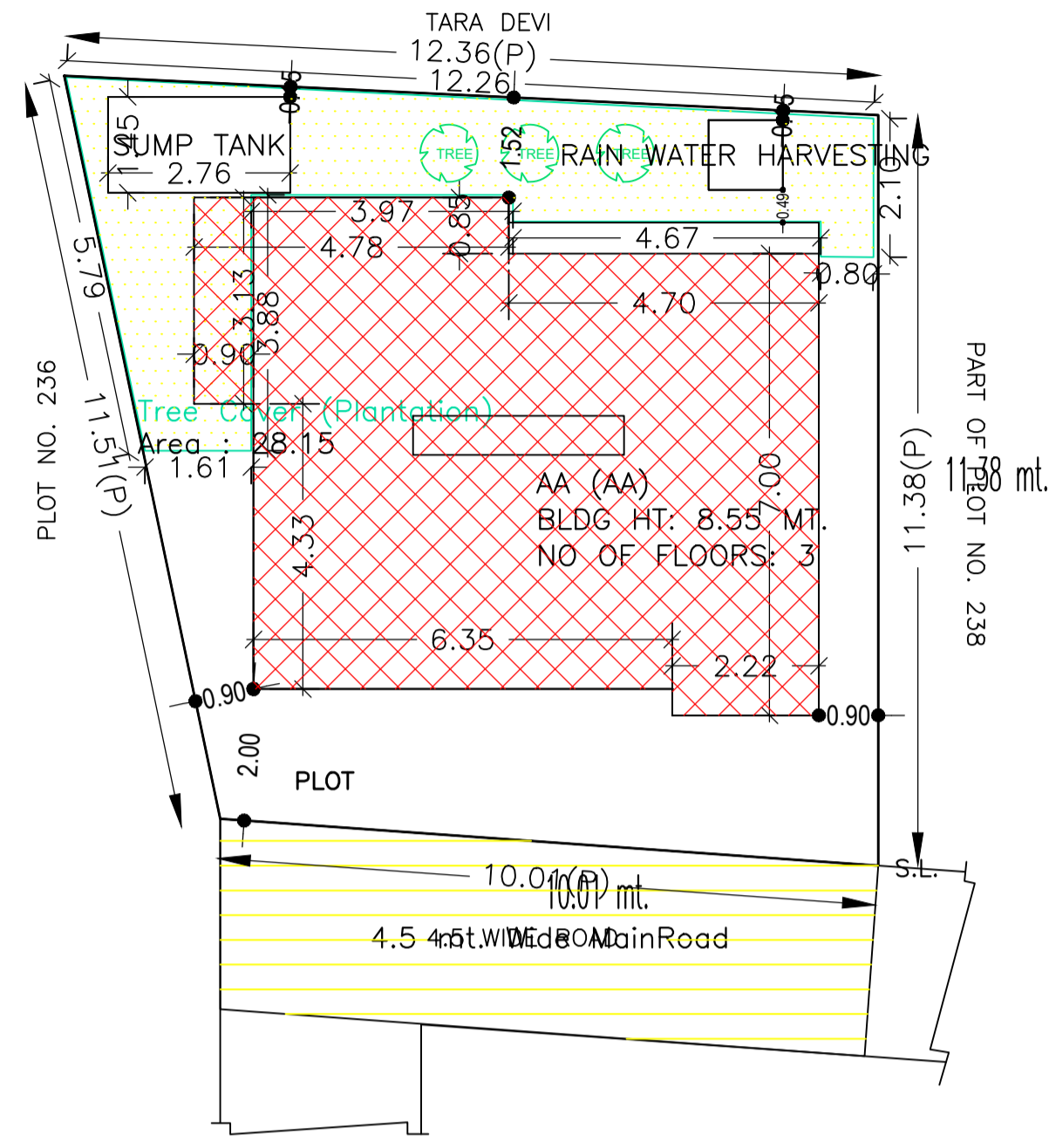

SITE PLAN

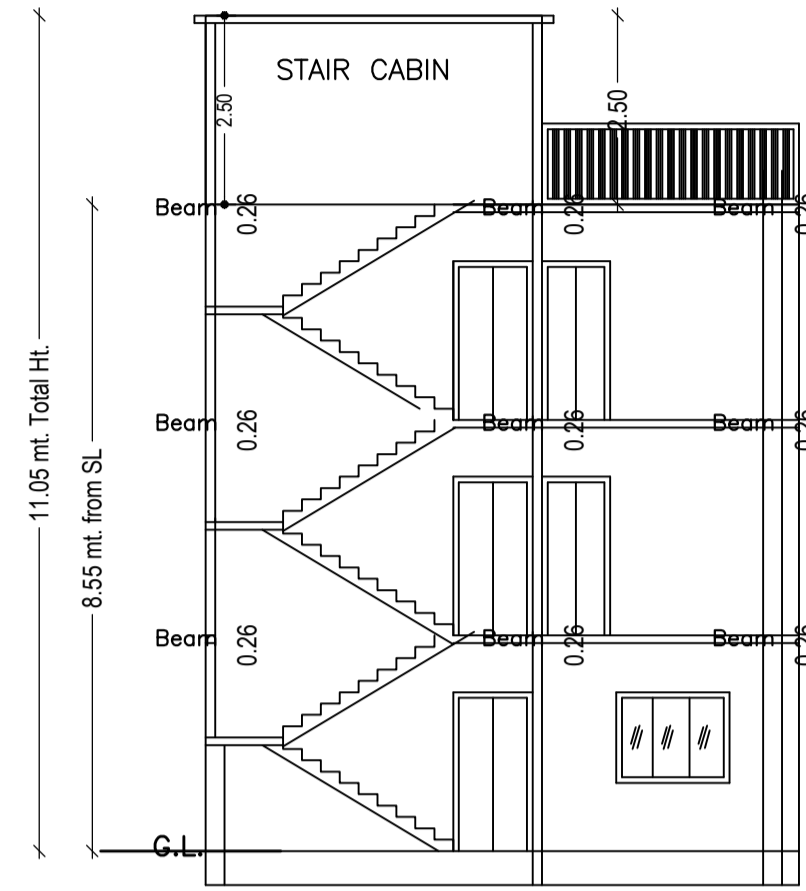

SECTION ON X-X

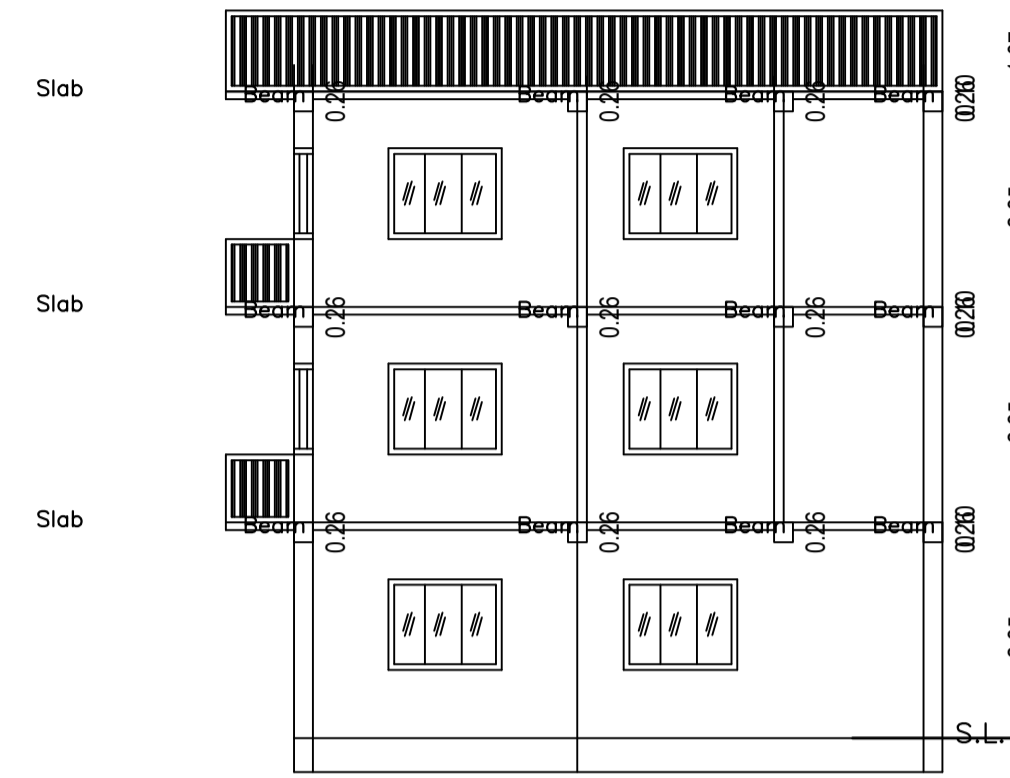

SECTION ON Y-Y

FAR & Tenement Details (Table 4c-1)

Building	No. of Same Bldg	Total Built Up Area (Sq.mt.)	Proposed FAR Area (Sq.mt.)	Total FAR Area (Sq.mt.)	Total Consumed Additional FAR Area (Sq.mt.)	Trmt (No.)
AA (AA)	1	188.05	188.05	188.05	188.05	01
Grand Total :	1	188.05	188.05	188.05	188.05	01

COLOR INDEX	
PLOT BOUNDARY	Black
ABUTTING ROAD	Green
PROPOSED CONSTRUCTION	Red
COMMON PLOT	Yellow
ROAD WIDENING AREA	Blue
EXISTING (To be retained)	Light Blue
EXISTING (To be demolished)	Dark Blue

Building USE/SUBUSE Details

Building Name	Building Use	Building SubUse	Building Structure
AA (AA)	Residential	Residential Bldg/Apartment	Non-Highrise

Buildingwise Floor FAR Details

Floor Name	AA (AA)		Total	
	Proposed Built Up Area (Sq.mt.)	Proposed FAR Area (Sq.mt.)	Total Proposed Built Up Area (Sq.mt.)	Total FAR Area (Sq.mt.)
Ground Floor	60.81	60.81	60.81	60.81
First Floor	63.62	63.62	63.62	63.62
Second Floor	63.62	63.62	63.62	63.62
Terrace Floor	0.00	0.00	0.00	0.00
Total :	188.05	188.05	188.05	188.05

SITE PLAN

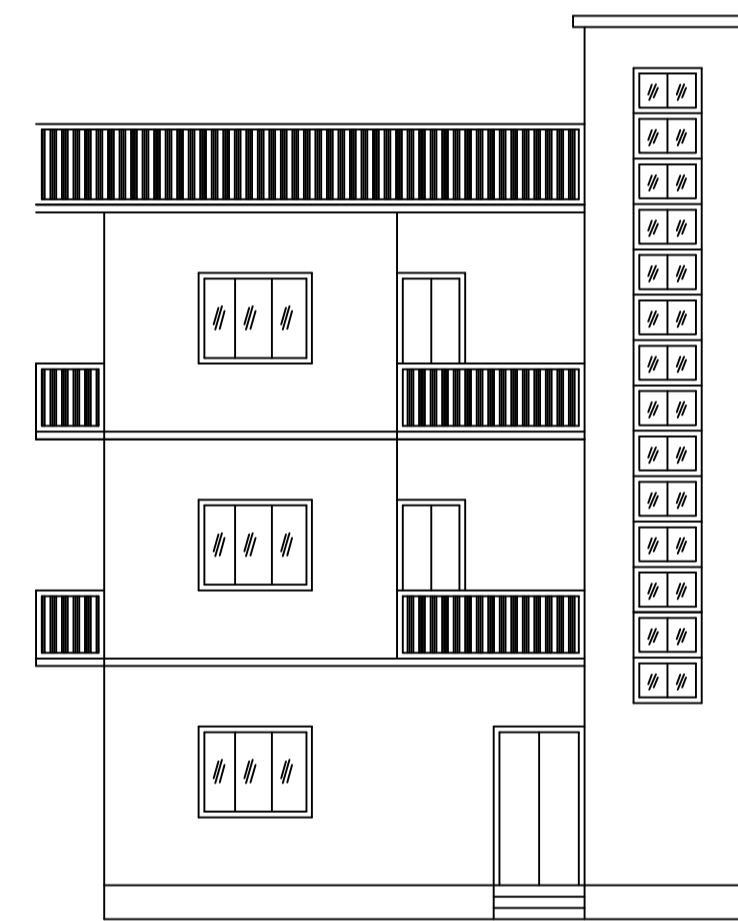
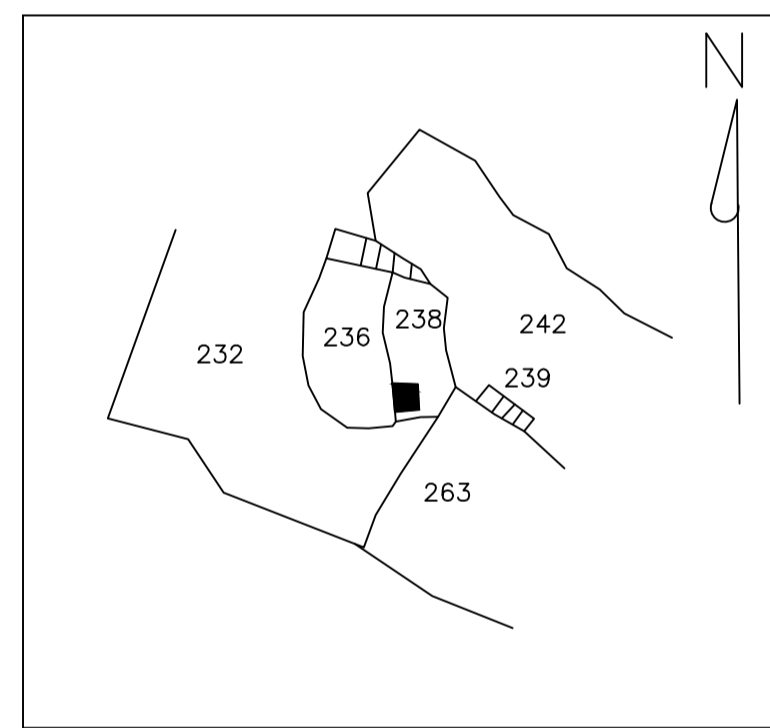
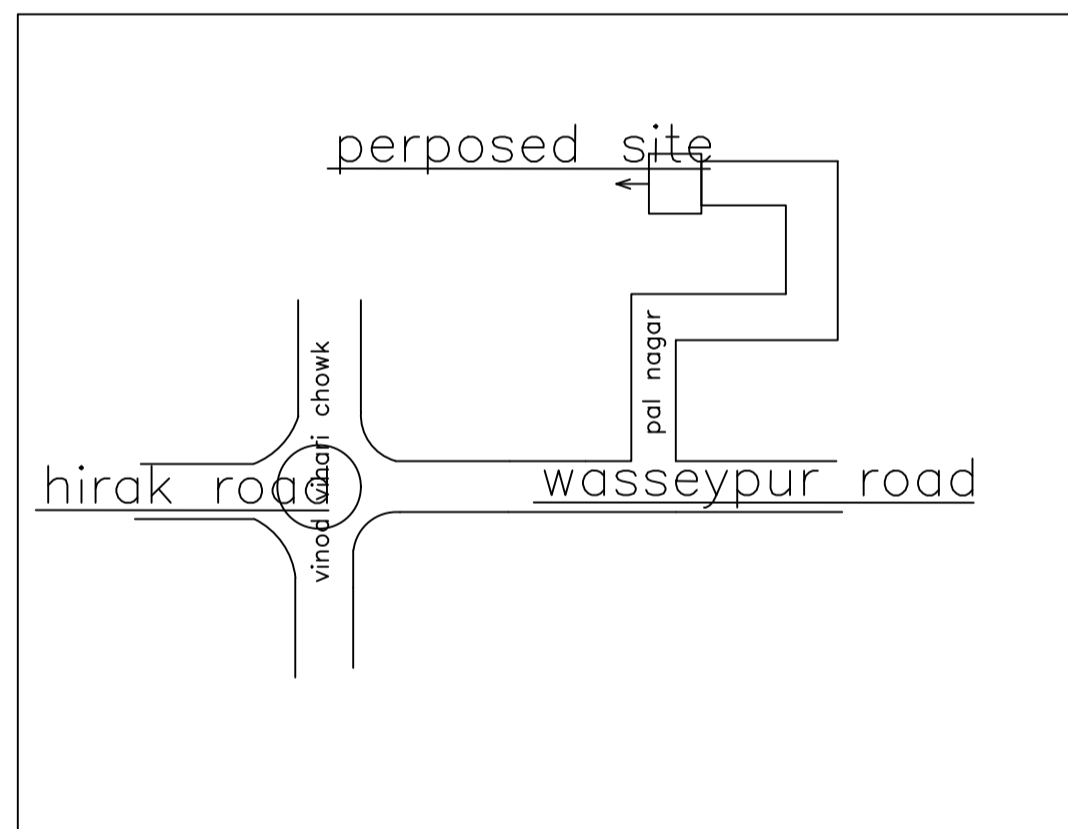

FRONT ELEVATION

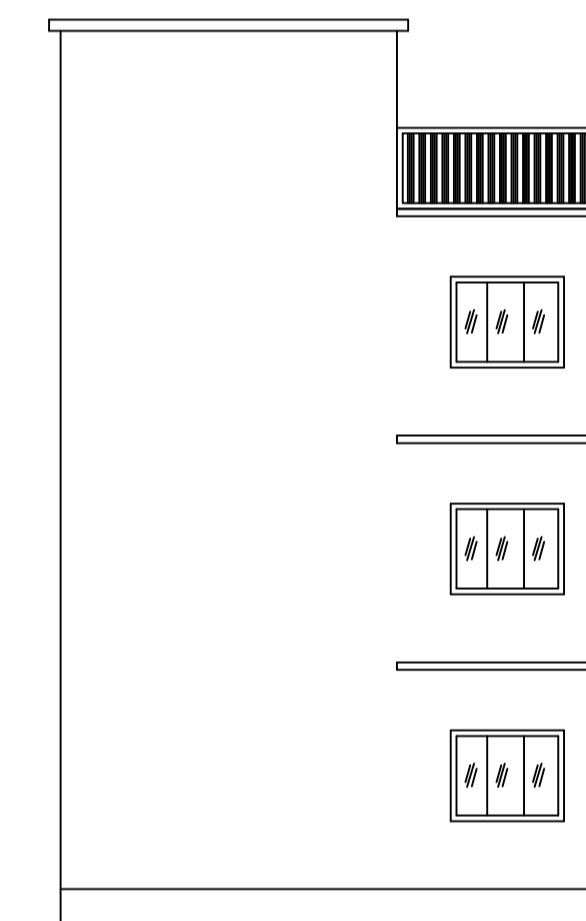

RIGHT SIDE ELEVATION

SCHEDULE OF DOOR:

BUILDING NAME	NAME	LENGTH	HEIGHT	NOS
AA (AA)	D2	0.90	2.10	06
AA (AA)	D1	1.05	2.10	07
AA (AA)	D	1.20	2.10	01

SCHEDULE OF WINDOW/VENTILATION:

BUILDING NAME	NAME	LENGTH	HEIGHT	NOS
AA (AA)	W1	0.60	1.20	02
AA (AA)	W2	0.90	1.20	03
AA (AA)	W	1.50	1.20	18

Building :AA (AA)

Floor Name	Total Built Up Area (Sq.mt.)	Proposed FAR Area (Sq.mt.)	Total FAR Area (Sq.mt.)	Total Consumed Additional FAR Area (Sq.mt.)	Trmt (No.)
Ground Floor	60.81	60.81	60.81	60.81	01
First Floor	63.62	63.62	63.62	63.62	00
Second Floor	63.62	63.62	63.62	63.62	00
Terrace Floor	0.00	0.00	0.00	0.00	00
Total :	188.05	188.05	188.05	188.05	01
Total Number of Same Buildings	1				
Total :	188.05	188.05	188.05	188.05	01

UnitBUA Table for Building :AA (AA)

FLOOR	Name	UnitBUA Type	UnitBUA Area	Carpet Area	No. of Rooms	No. of Tenement
GROUND FLOOR PLAN	SPLIT AA	FLAT	188.06	187.31	1	1
TYPICAL -1, 2 FLOOR PLAN	SPLIT AA	FLAT	0.00	0.00	6	0
Total :	-	-	188.06	187.31	13	1

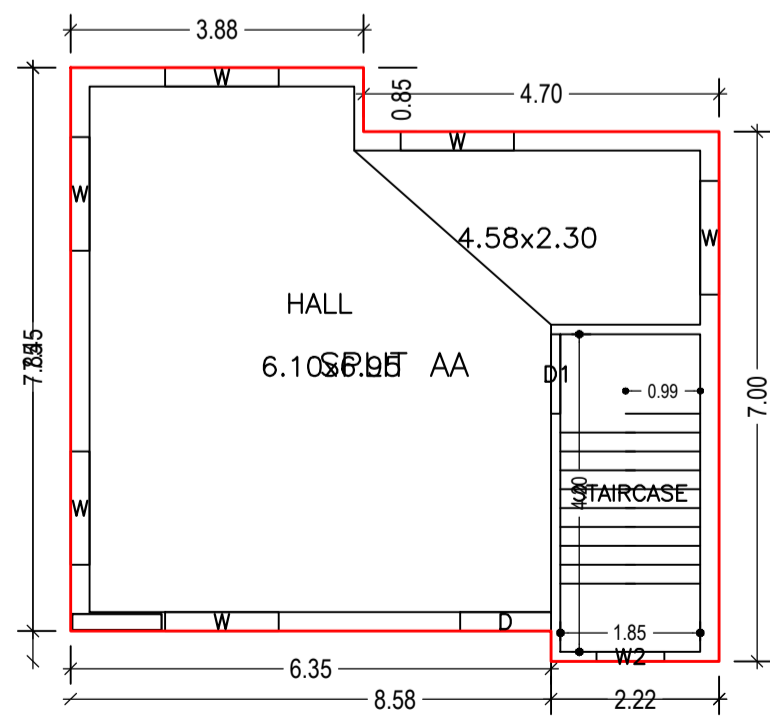

GROUND FLOOR PLAN (Proposed) (SCALE 1:100)

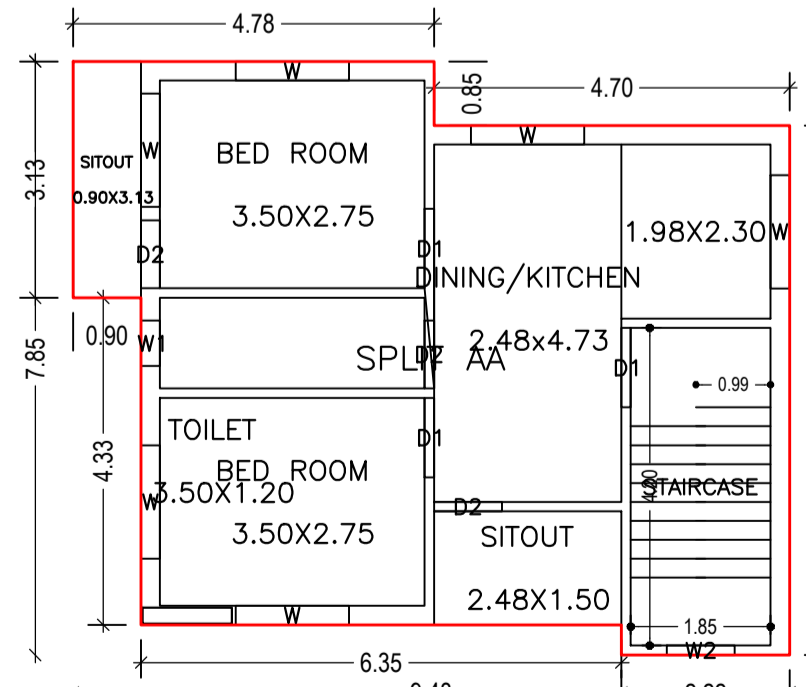

TYPICAL - 1, 2 FLOOR PLAN (Proposed) (SCALE 1:100)

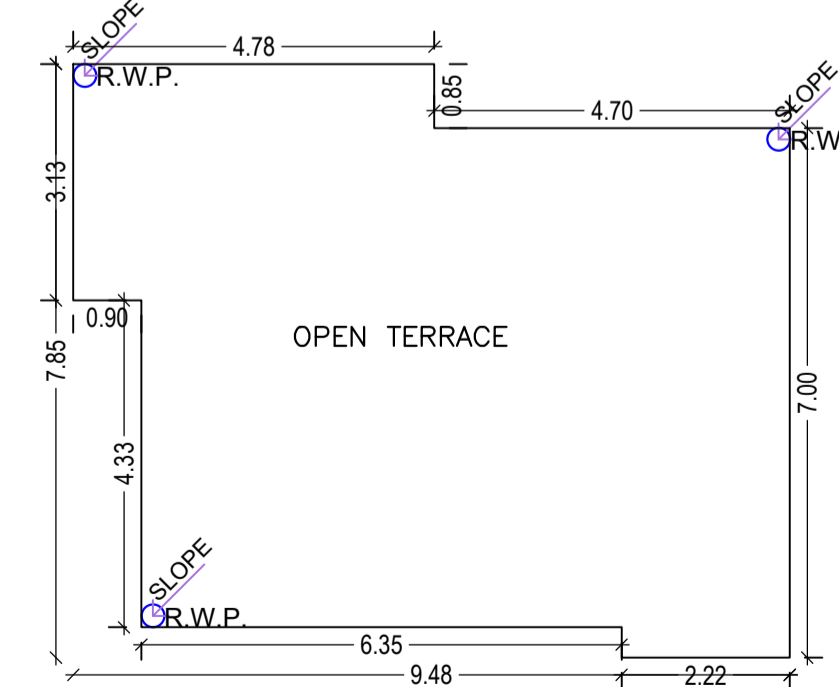

TERRACE FLOOR PLAN (SCALE 1:100)

AREA STATEMENT		VERSION NO. : 1.0.50
DHANBAD MUNICIPAL CORPORATION		VERSION DATE: 16/10/2020
PROJECT DETAIL:		
Region: JHARKHAND URBAN LOCAL BODIES	Plot Use: Residential	
District: DHANBAD	Plot SubUse: Bungalow/ Dwelling / Non Apartment	
Authority: DHANBAD MUNICIPAL CORPORATION	PlotNearby/ReligiousStructure: NA	
Inward No: DMC/BP/0205/W20/2020	Plot/SubPlot No: 238(OLD),268(NEW)	
Application Type: General Proposal	North: Plot No. - tara devi	
Project Type: Building Permission	South: Road Width - 4.87	
Nature of Development: New	East: Plot No. - plot no 238	
Location of Development Area: Old Area	West: Plot No. - plot no 236	
AREA DETAILS:		
AREA OF PLOT (Minimum)	(A)	SQ.MT. 125.66
NET AREA OF PLOT(Gross Plot Area - Deduction from Gross Plot area)	(A-Deductions)	125.66
Deduction for Balance Plot Area(from Gross Plot Area)		
Common Plot		28.15
Total		28.15
BALANCE AREA OF PLOT(Net Plot Area - Recreational/Amenity space)	(A-Deductions)	97.51
PLOT AREA FOR COVERAGE(Net Plot Area)	(A-Deductions)	125.66
Plot Area for FAR (Net Plot Area + RoadWidening Area)	(A-Deductions)	125.66
COVERAGE CHECK		
Permissible Coverage area (70.00 %)		87.96
Proposed Coverage Area (50.63 %)		63.62
Total Prop. Coverage Area (50.63 %)		63.62
Balance coverage area (19.37 %)		24.34
FAR CHECK		
Perm. FAR Area (1.50)		188.49
Total Perm. FAR area		188.49
Residential FAR		188.06
Proposed FAR Area		188.06
Total Proposed FAR Area		188.06
Consumed FAR (Factor)		1.50
Balance FAR Area		0.43
BUILT UP AREA CHECK		
Total Proposed BuiltUp Area		188.05
ARCHITECT (Regd)	PARTHA - PAL	
ENGINEER (Regd)		
SUPERVISOR (Regd)		
OWNER (Regd)	REKHA DEVI	
DEVELOPMENT AUTHORITY		LOCAL BODY

LTP NAME AND SIGNATURE	STRUCTURAL ENG'S NAME AND SIGNATURE	BUILDER NAME AND SIGNATURE	DIGITAL SIGNATURE
PARTHA - PAL DMC/ENG/0021/2016			

Proposal Basic Information	
Proposal File No.	DMC/BP/0205/W20/2020
Owner Name	REKHA DEVI
Khata No	63(old),387(new)
Plot No	238(OLD),268(NEW)
Village Name	Panderpala
Use	Residential
SubUse	Bungalow/ Dwelling / Non Apartment

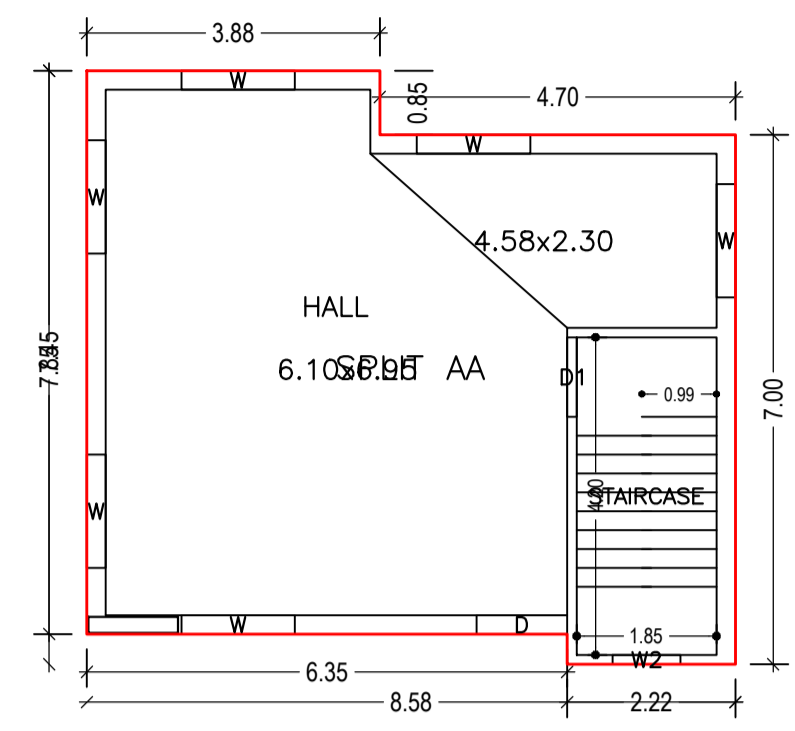

GROUND FLOOR PLAN
(Proposed)
(SCALE 1:100)

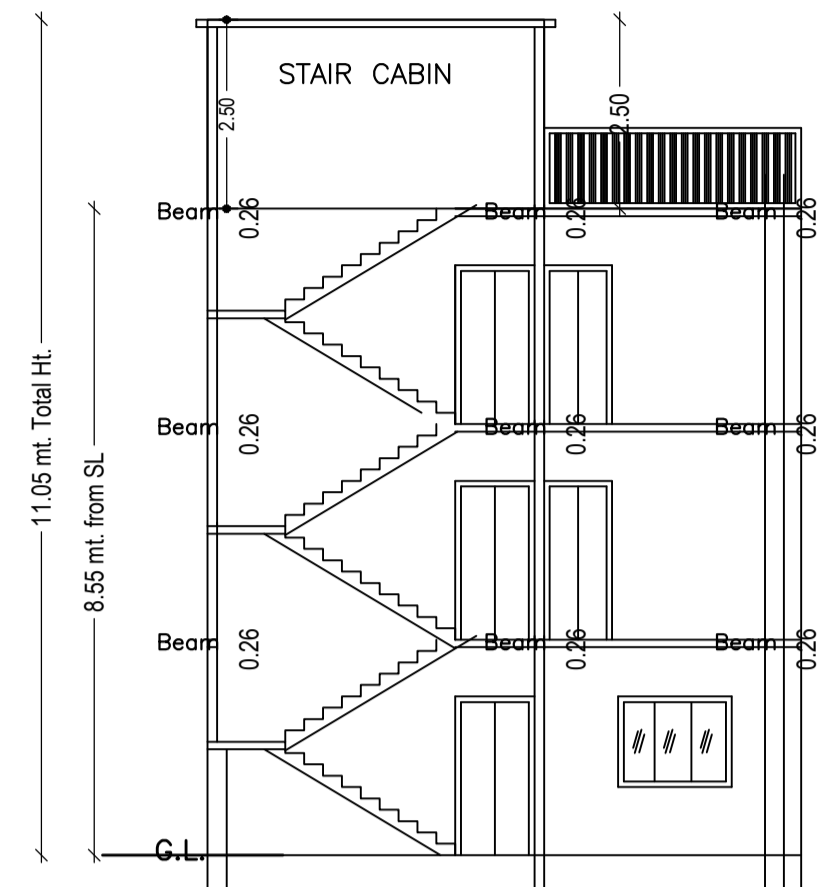

SECTION ON X-X

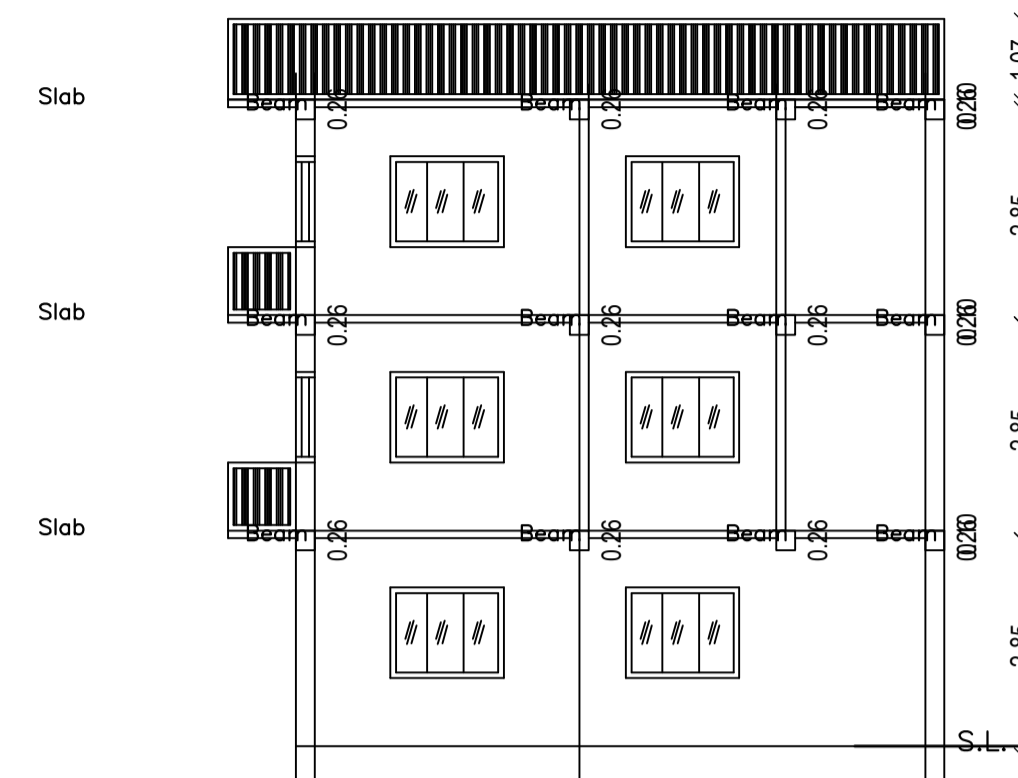

SECTION ON Y-Y

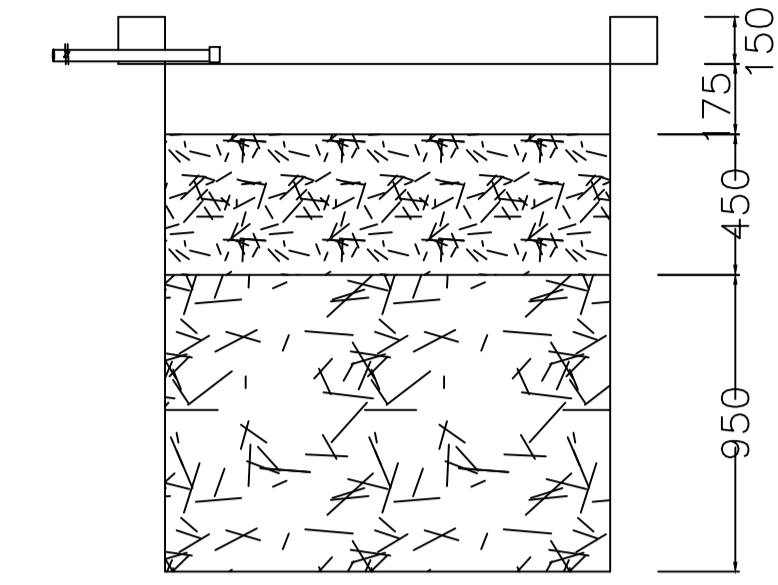

SECTION AT Y-Y

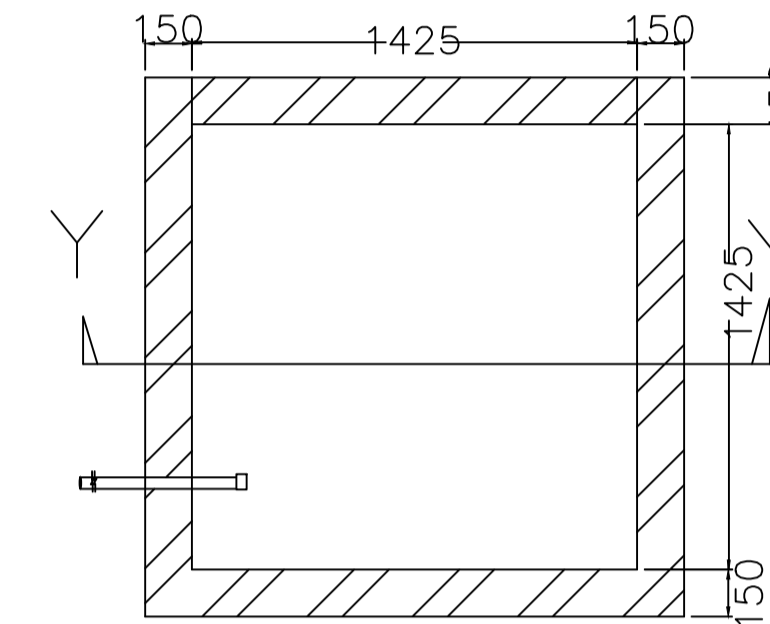

PLAN OF RECHARGE WELL

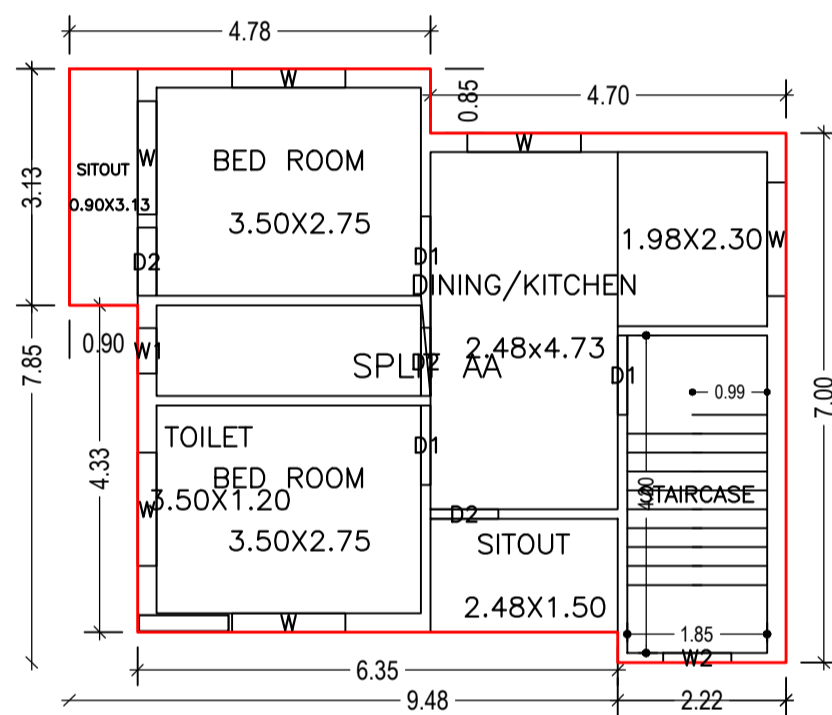

TYPICAL - 1, 2 FLOOR PLAN
(Proposed)
(SCALE 1:100)

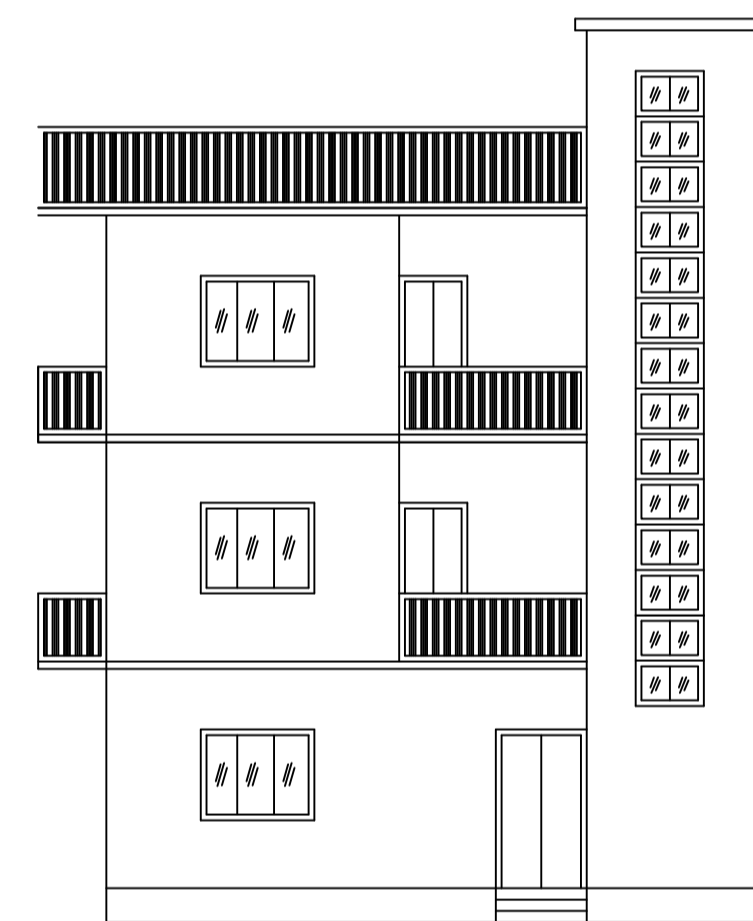

FRONT ELEVATION

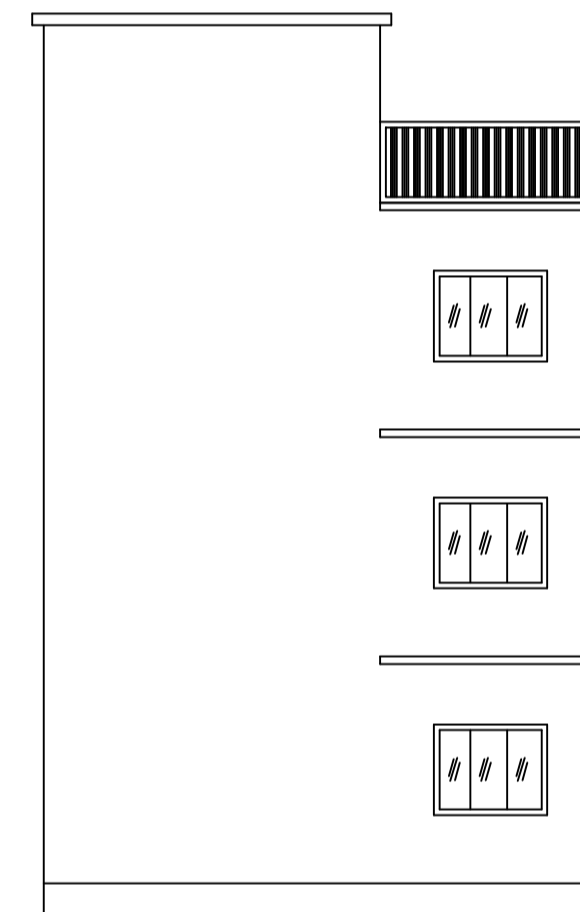

RIGHT SIDE ELEVATION

WATER HARVESTING

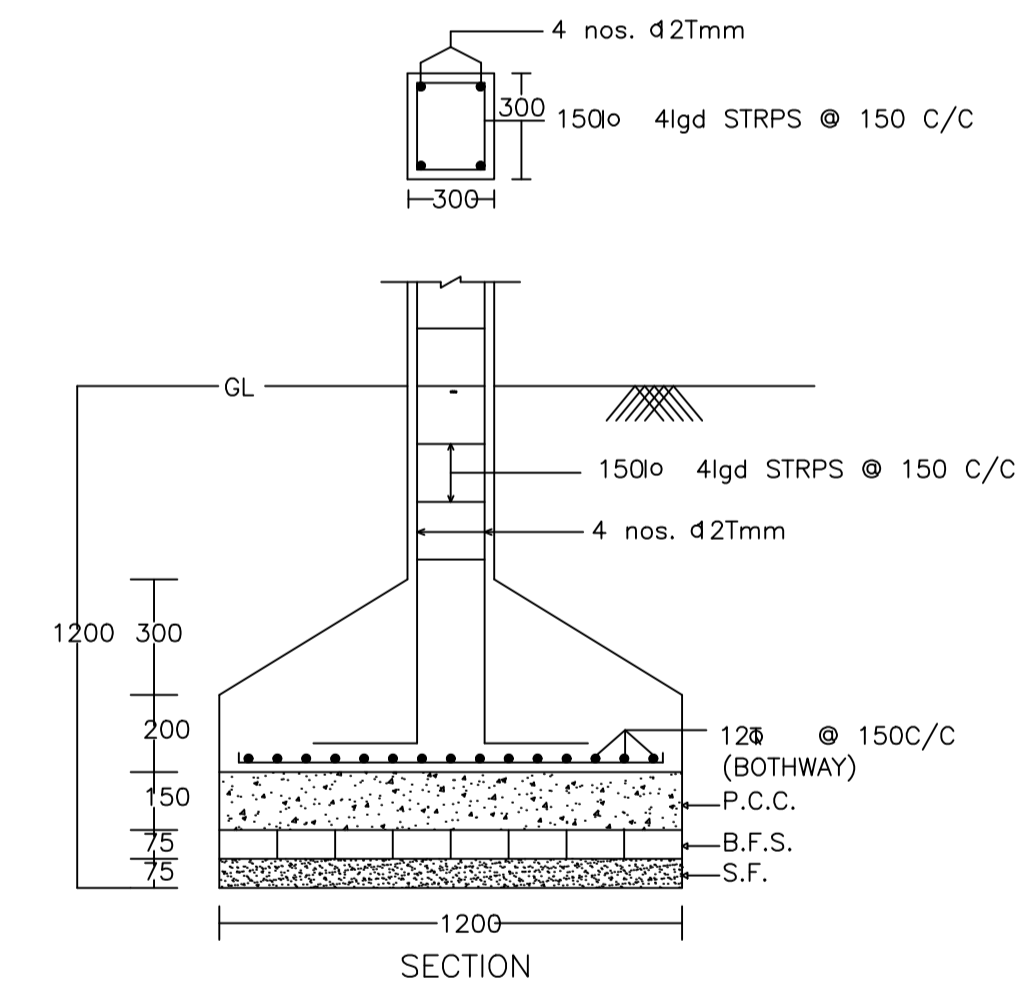

SECTION

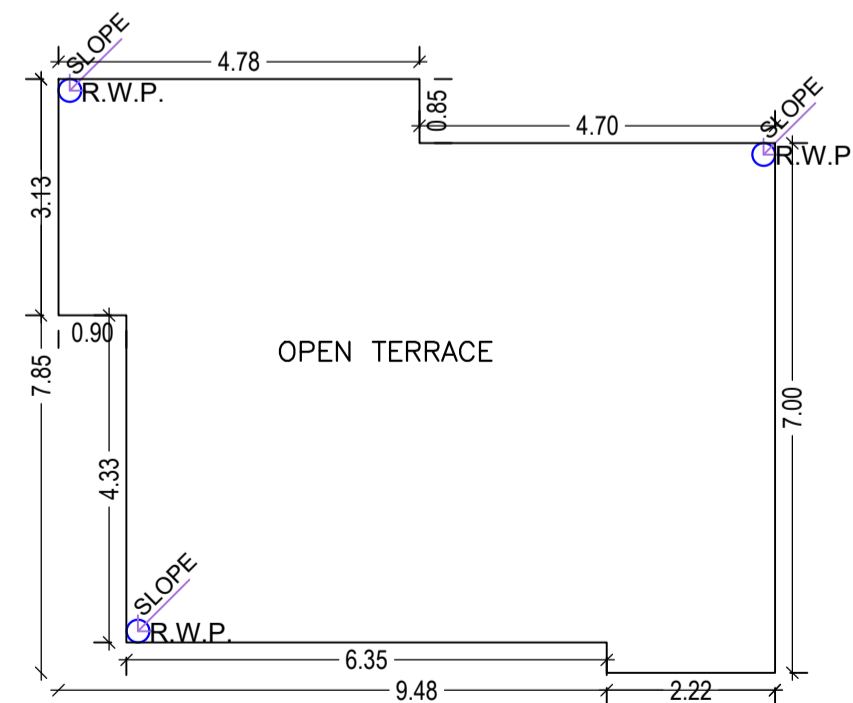

TERRACE FLOOR PLAN
(SCALE 1:100)

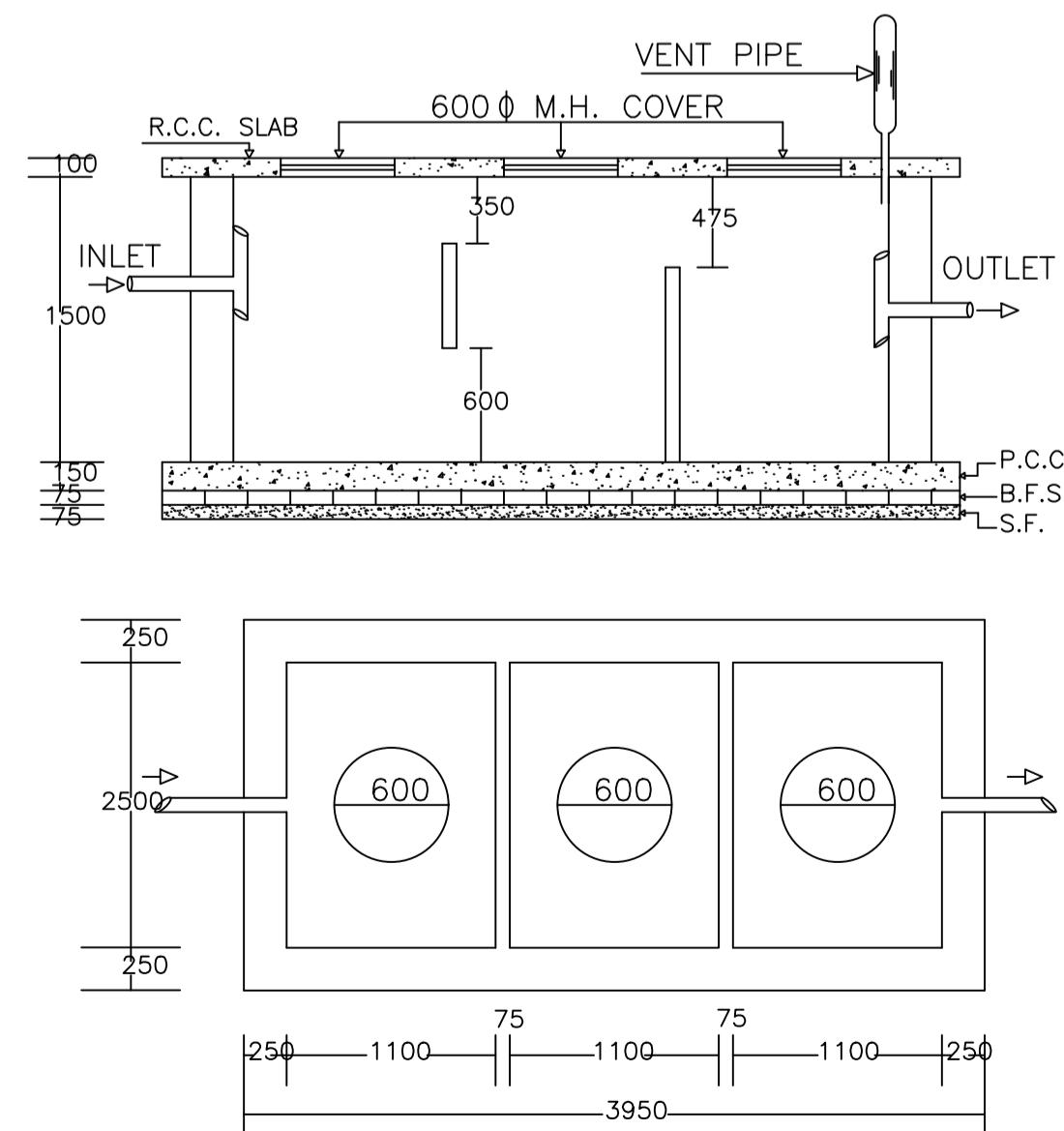

PLAN OF SEPTIC TANK

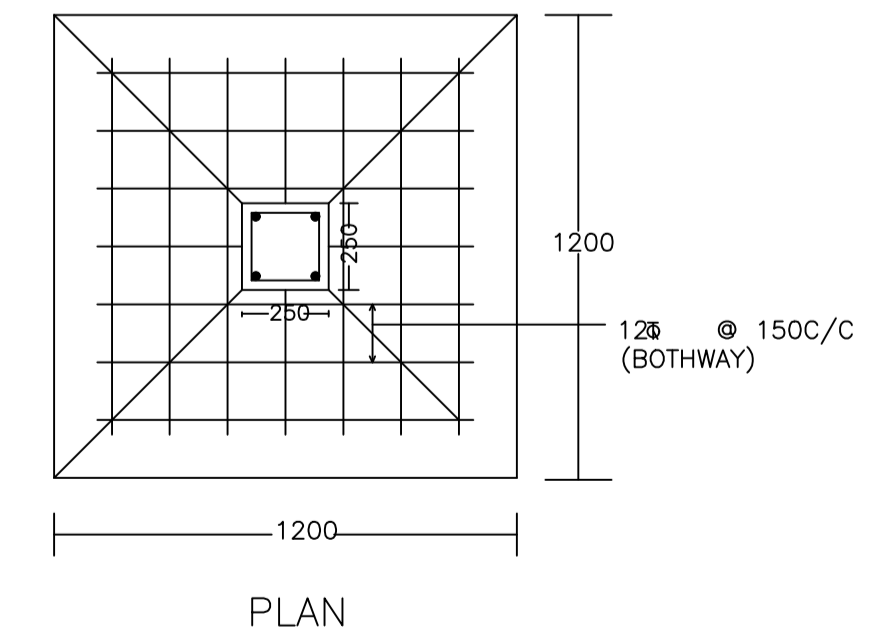
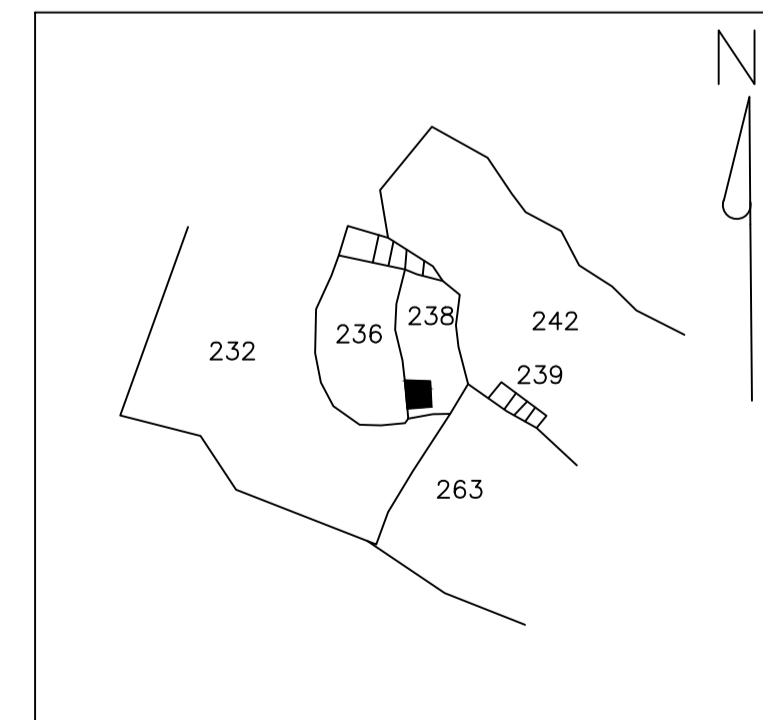

PLAN

DETAIL OF COLUMNS

LTP NAME AND SIGNATURE	STRUCTURAL ENG'S NAME AND SIGNATURE	BUILDER NAME AND SIGNATURE	DIGITAL SIGNATURE
PARTHA - PAL DMC/ENG/0021/2016			