

AREA STATEMENT	VERSION NO.: 1.0.53
DHANBAD MUNICIPAL CORPORATION	VERSION DATE: 16/10/2020
PROJECT DETAIL:	
Region: JHARKHAND URBAN LOCAL BODIES	Plot Use: Residential
District: DHANBAD	Plot SubUse: Bungalow/ Dwelling / Non Apartment
Authority: DHANBAD MUNICIPAL CORPORATION	PlotNearby/ReligiousStructure: NA
Inward No: DMC/BP/0289/W23/2020	Plot/SubPlot No: NEW - 410 , OLD - 559
Application Type: General Proposal	North: Plot No. - PART OF THIS PLOT
Project Type: Building Permission	South: Plot No. - REKHA PANDEY
Nature of Development: New	East: Road Width - 3.065 M WIDE ROAD
Location of Development Area: Old Area	West: Plot No. - PLOT NO - 4111
AREA DETAILS:	
AREA OF PLOT (Minimum)	200.17 SQ.MT.
Deduction for NetPlot Area	
Surrender Free of Cost	7.93
Total	7.93
NET AREA OF PLOT (Gross Plot Area - Deduction from Gross Plot Area)	192.24
Deduction for Balance Plot Area(from Gross Plot Area)	
Surrender Free of Cost	7.93
Common Plot	29.67
Total	37.60
BALANCE AREA OF PLOT (Net Plot Area - Recreational/Amenity space)	162.57
PLOT AREA FOR COVERAGE (Net Plot Area)	192.24
Plot Area for FAR (Net Plot Area + Road Widening Area)	200.17
COVERAGE CHECK	
Permissible Coverage area (70.00 %)	134.57
Proposed Coverage Area (44.98 %)	86.47
Total Prop. Coverage Area (44.98 %)	86.47
Balance coverage area (25.02 %)	48.10
FAR CHECK	
Perm. FAR Area (1.50)	300.26
Total Perm. FAR area	300.26
Residential FAR	181.29
Proposed FAR Area	181.29
Total Proposed FAR Area	181.29
Consumed FAR (Factor)	0.91
Balance FAR Area	118.97
BUILT UP AREA CHECK	
Total Proposed BuiltUp Area	181.29
ARCHITECT (Regd)	Ashish kr singh
ENGINEER (Regd)	
SUPERVISOR (Regd)	
OWNER (Regd)	SMT SARITA PANDEY
DEVELOPMENT AUTHORITY LOCAL BODY	

COLOR INDEX	
PLOT BOUNDARY	Black
ABUTTING ROAD	Red
PROPOSED CONSTRUCTION	Green
COMMON PLOT	Yellow
ROAD WIDENING AREA	Blue
EXISTING (To be retained)	Orange
EXISTING (To be demolished)	Light Blue

Buildingwise Floor FAR Details

Floor Name	Building Name		Total	
	Proposed Built Up Area (Sq.mt.)	Proposed FAR Area (Sq.mt.)	Total Proposed Built Up Area (Sq.mt.)	Total FAR Area (Sq.mt.)
Ground Floor	86.47	86.47	86.47	86.47
First Floor	94.82	94.82	94.82	94.82
Terrace Floor	0.00	0.00	0.00	0.00
Total :	181.29	181.29	181.29	181.29

Building USE/SUBUSE Details

Building Name	Building Use	Building SubUse	Building Structure
A (A)	Residential	Bungalow/ Dwelling / Non Apartment	Non-Highrise

SCHEDULE OF DOOR:

BUILDING NAME	NAME	LENGTH	HEIGHT	NOS
A (A)	D	0.76	2.10	06
A (A)	D	1.02	2.10	02
A (A)	D	1.07	2.10	07

SCHEDULE OF WINDOW/VENTILATION:

BUILDING NAME	NAME	LENGTH	HEIGHT	NOS
A (A)	W	0.61	1.20	04
A (A)	W	0.91	1.20	04
A (A)	W	1.22	1.20	04
A (A)	W	1.52	1.20	04
A (A)	W	2.23	1.20	01
A (A)	W	2.35	1.20	01

Building :A (A)

Floor Name	Total Built Up Area (Sq.mt.)	Proposed FAR Area (Sq.mt.)	Total FAR Area (Sq.mt.)	Total Consumed Additional FAR Area (Sq.mt.)	Tnmt (No.)
Ground Floor	86.47	86.47	86.47	86.47	01
First Floor	94.82	94.82	94.82	94.82	00
Terrace Floor	0.00	0.00	0.00	0.00	00
Total :	181.29	181.29	181.29	181.29	01
Total Number of Same Buildings :	1				
Total :	181.29	181.29	181.29	181.29	01

FAR & Tenement Details (Table 4c-1)

Building	No. of Same Bldg	Total Built Up Area (Sq.mt.)	Proposed FAR Area (Sq.mt.)	Total FAR Area (Sq.mt.)	Total Consumed Additional FAR Area (Sq.mt.)	Tnmt (No.)
A (A)	1	181.29	181.29	181.29	181.29	01
Grand Total:	1	181.29	181.29	181.29	181.29	01

UnitBUA Table for Building :A (A)

FLOOR	Name	UnitBUA Type	UnitBUA Area	Carpet Area	No. of Rooms	No. of Tenement
FIRST FLOOR	SPLIT A	FLAT	0.00	0.00	7	0
GROUND FLOOR	SPLIT A	FLAT	181.29	181.23	6	1
Total:	-	-	181.29	181.23	13	1

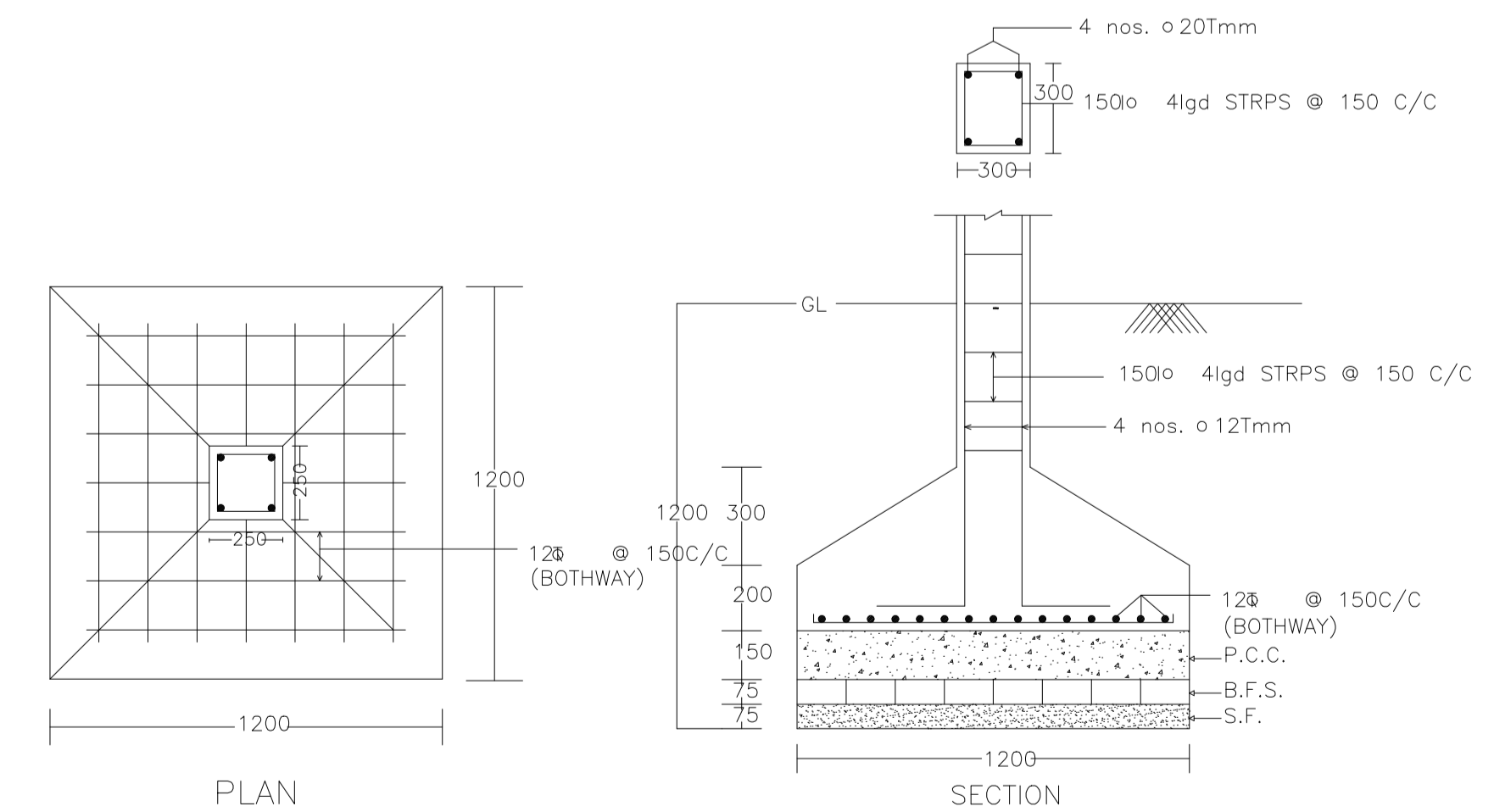
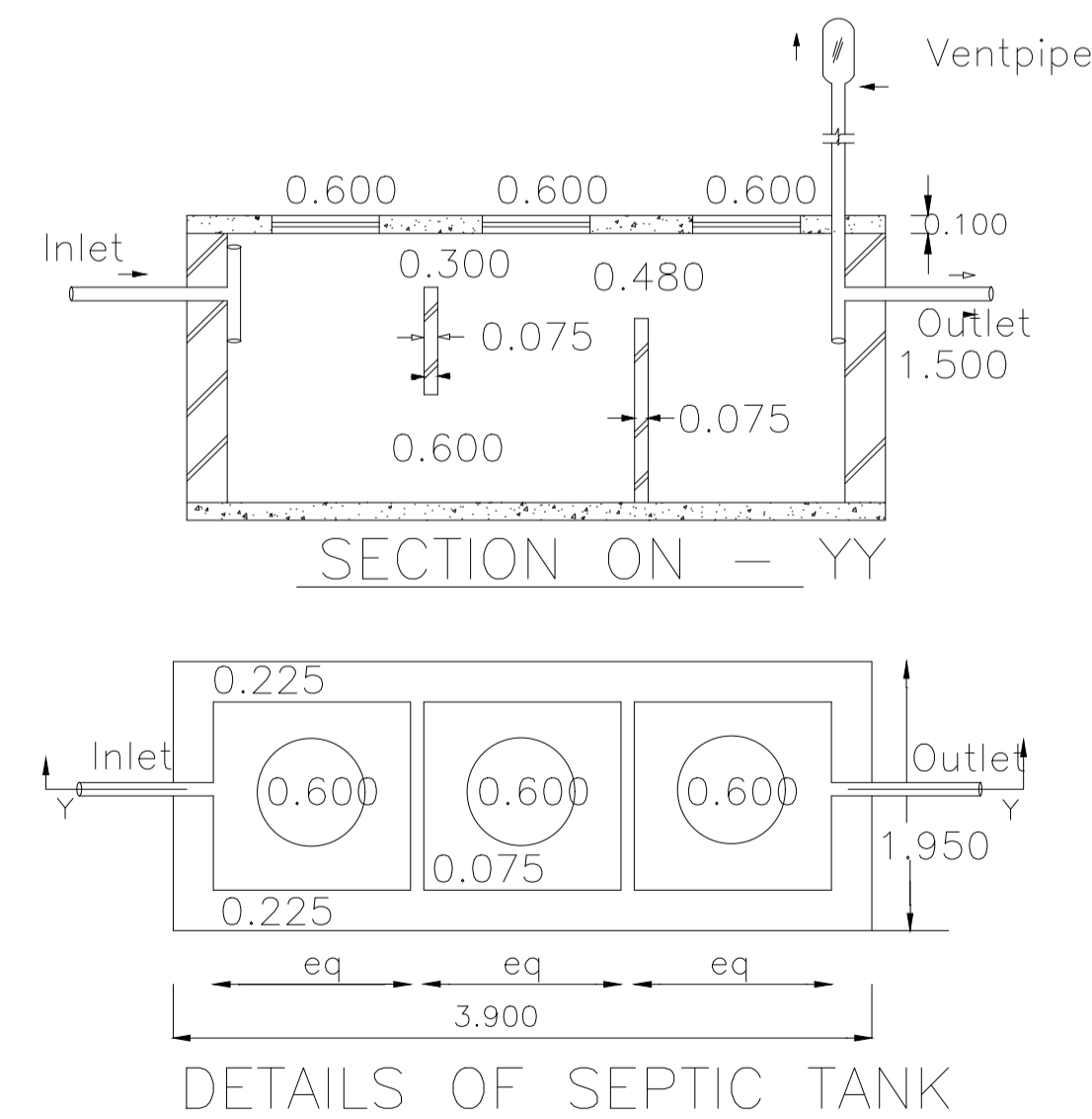
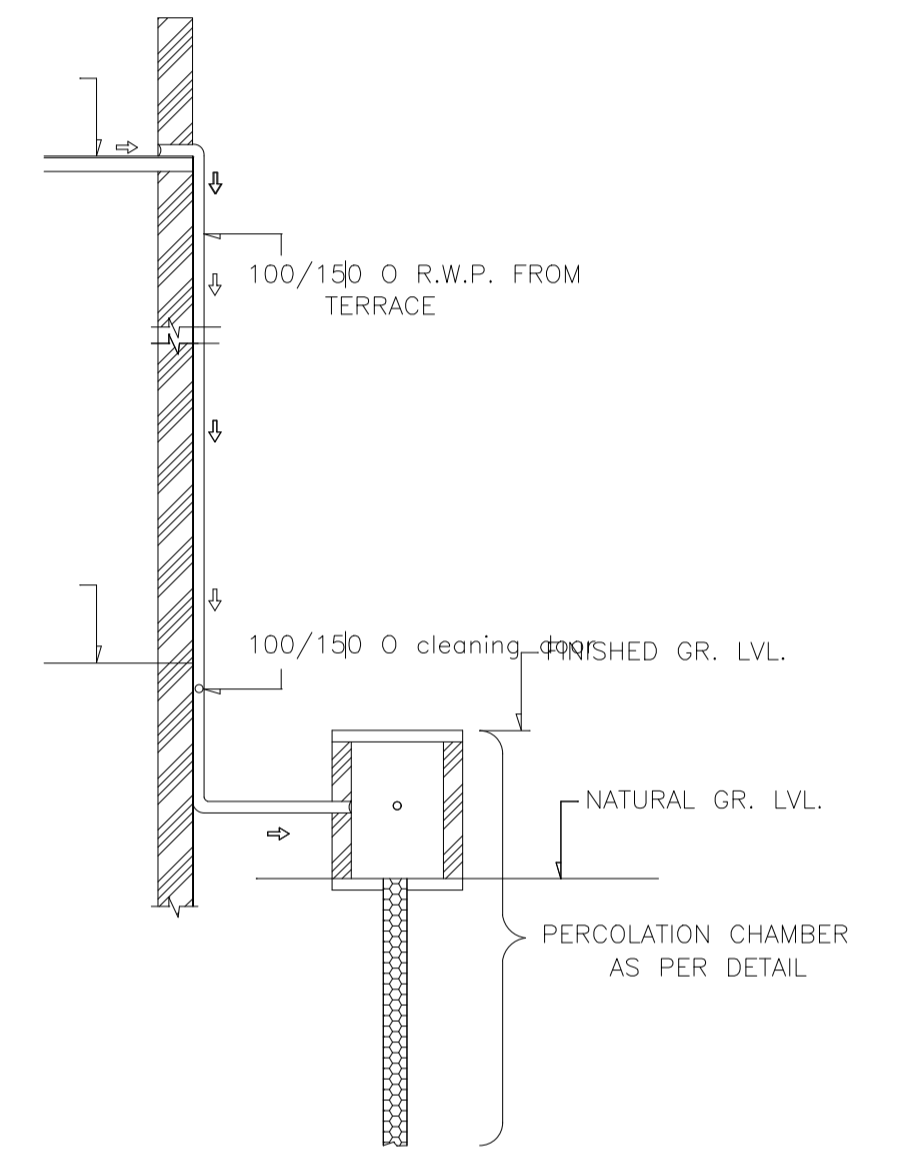
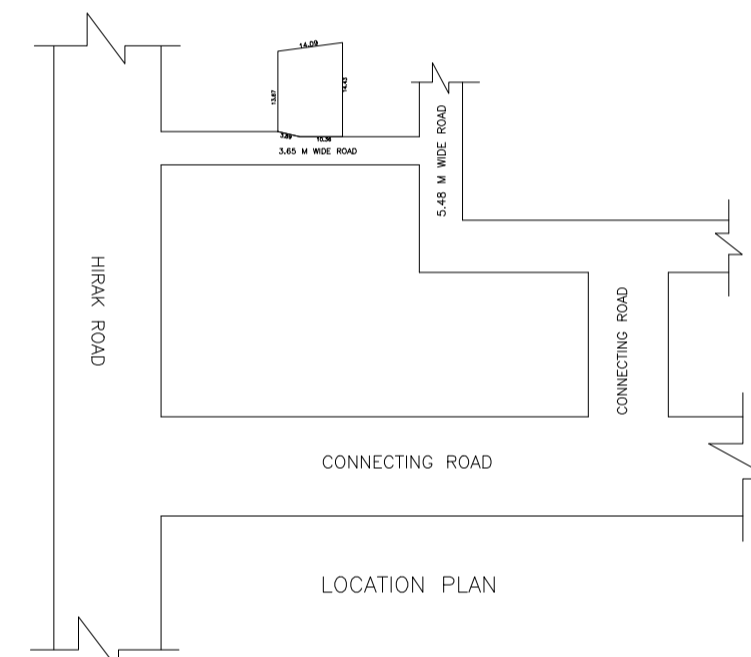
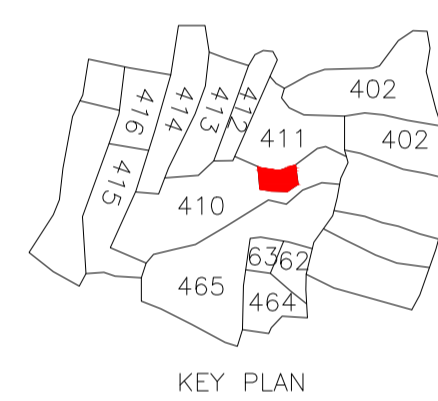
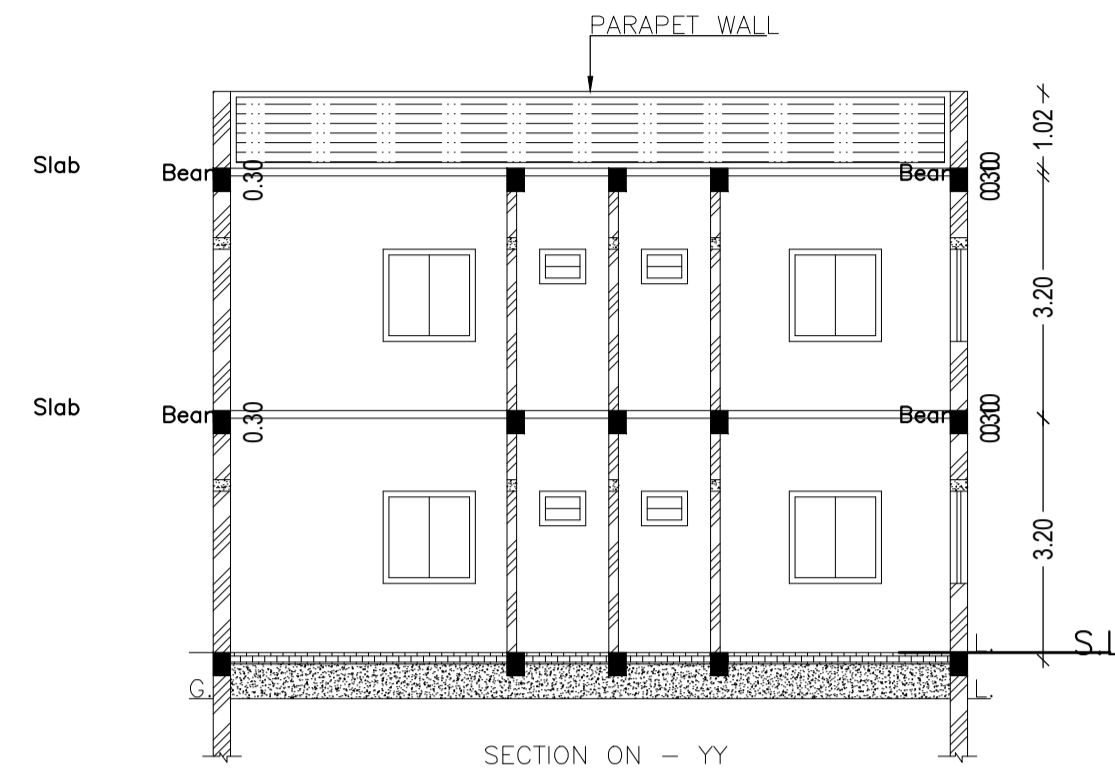
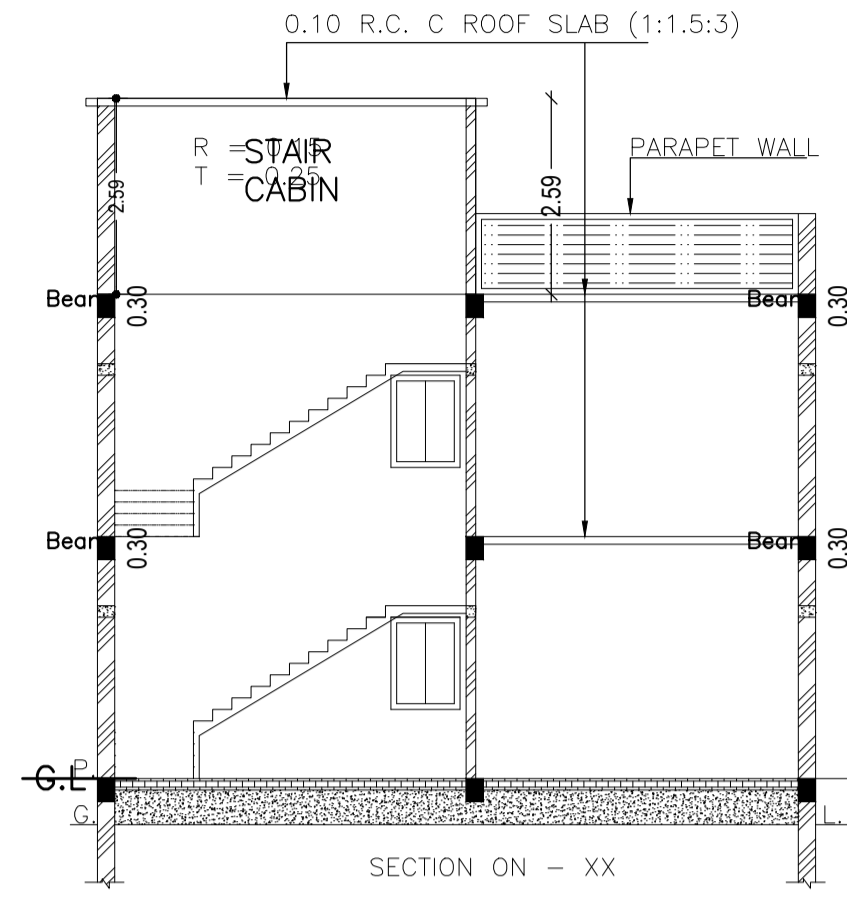
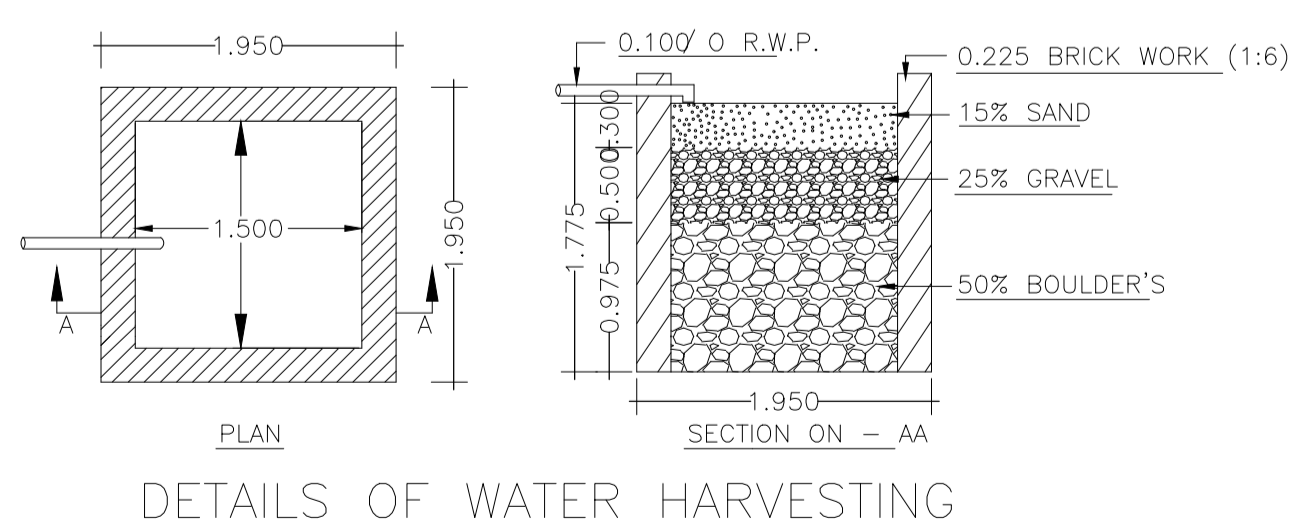
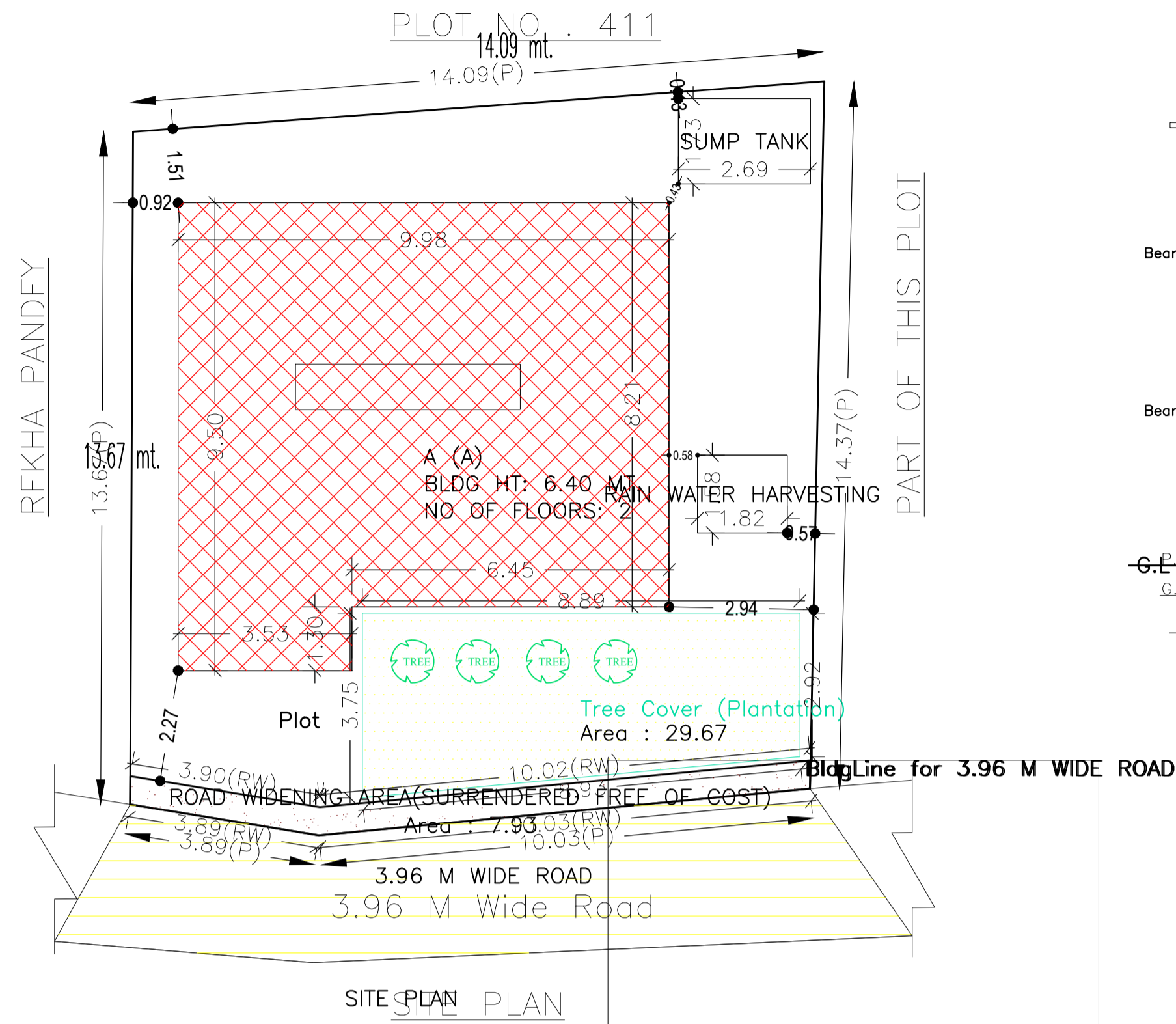

LTP NAME AND SIGNATURE	STRUCTURAL ENG'S NAME AND SIGNATURE	BUILDER NAME AND SIGNATURE	DIGITAL SIGNATURE
Ashish kr singh DMC/ARC/0016/2017			

Proposal Basic Information	
Proposal File No.	DMC/BP/0289/W23/2020
Owner Name	SMT SARITA PANDEY
Khata No	NEW - 17, OLD - 04
Plot No	NEW - 410, OLD - 559
Village Name	Sabalpur
Use	Residential
SubUse	Bungalow/ Dwelling / Non Apartment

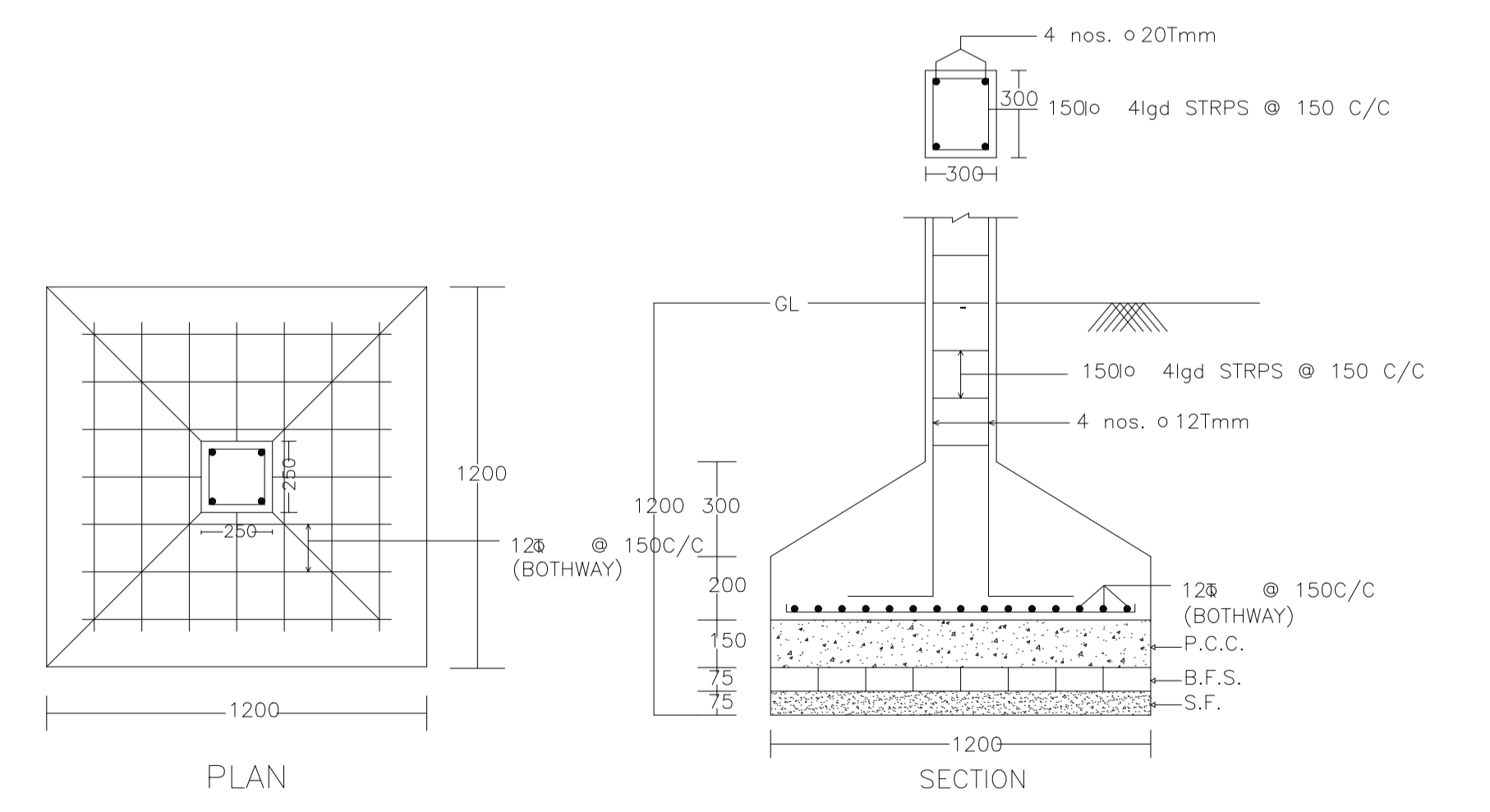
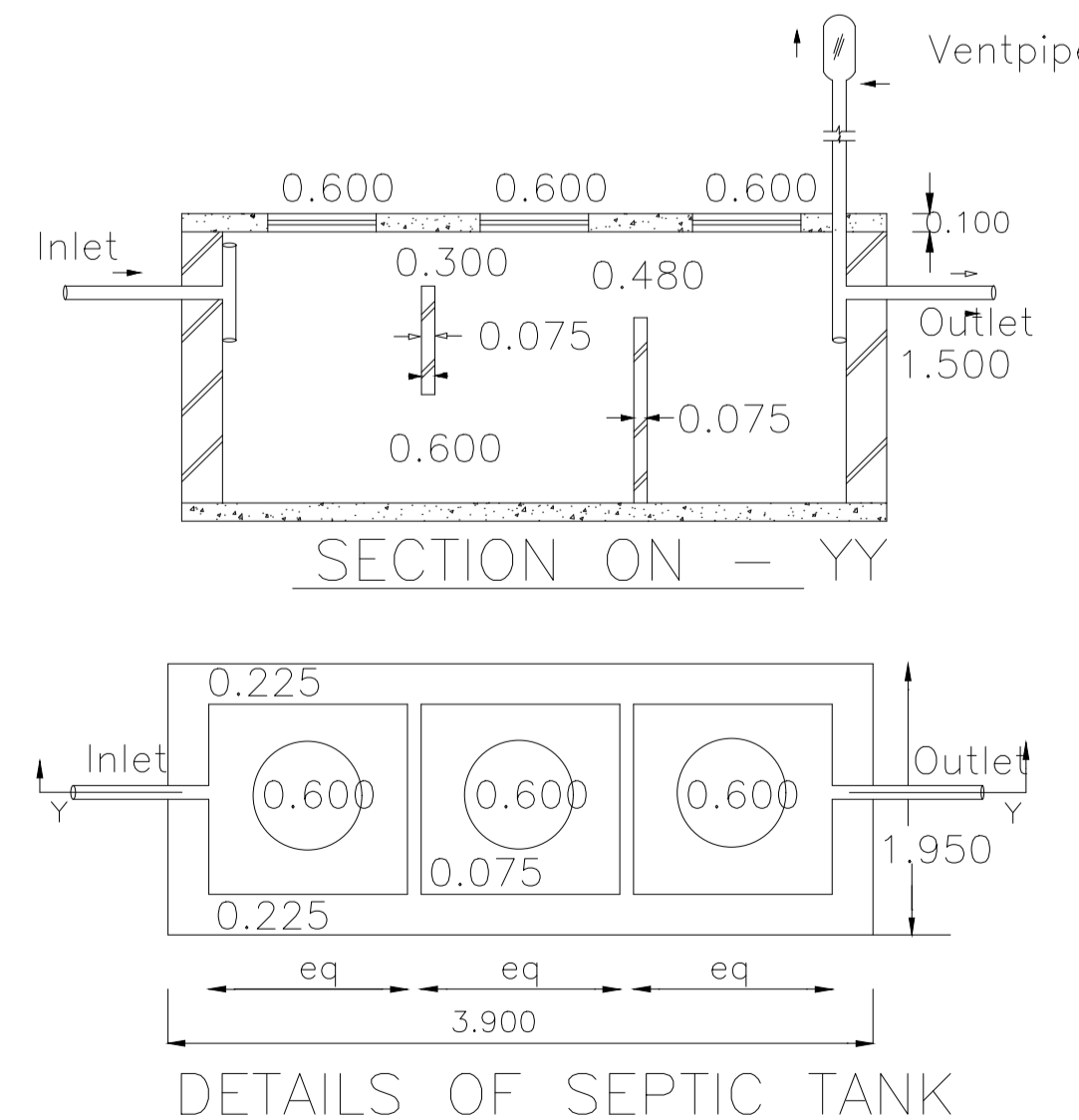
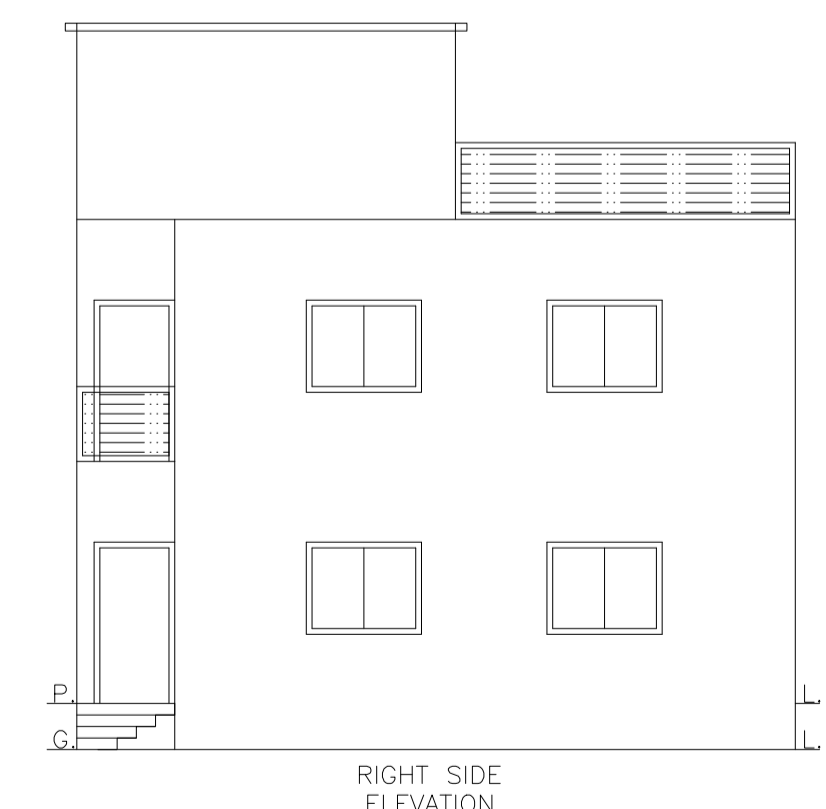
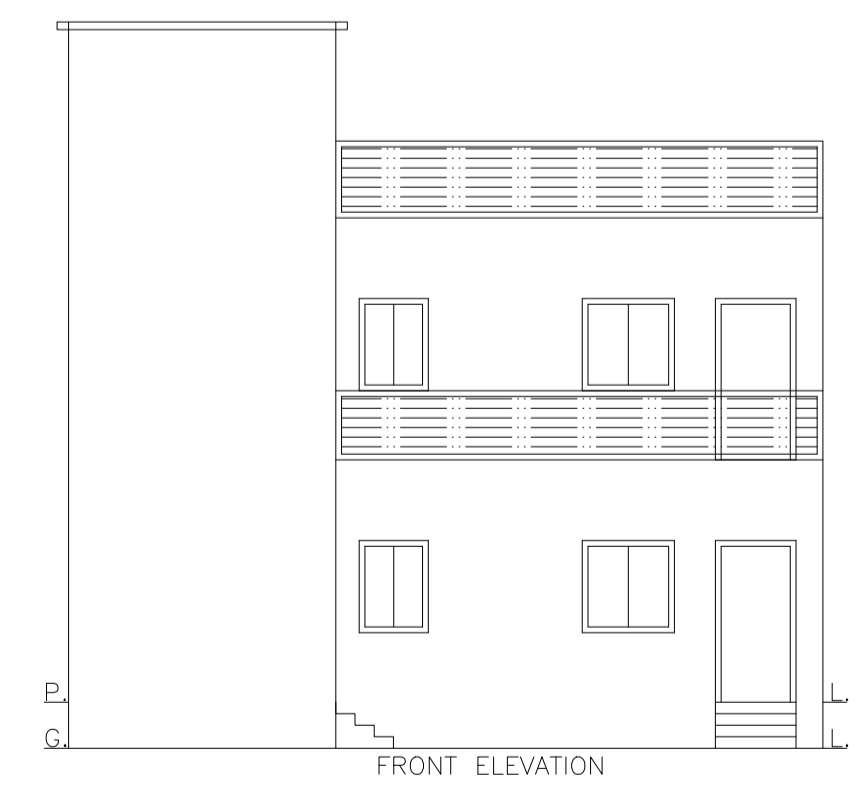
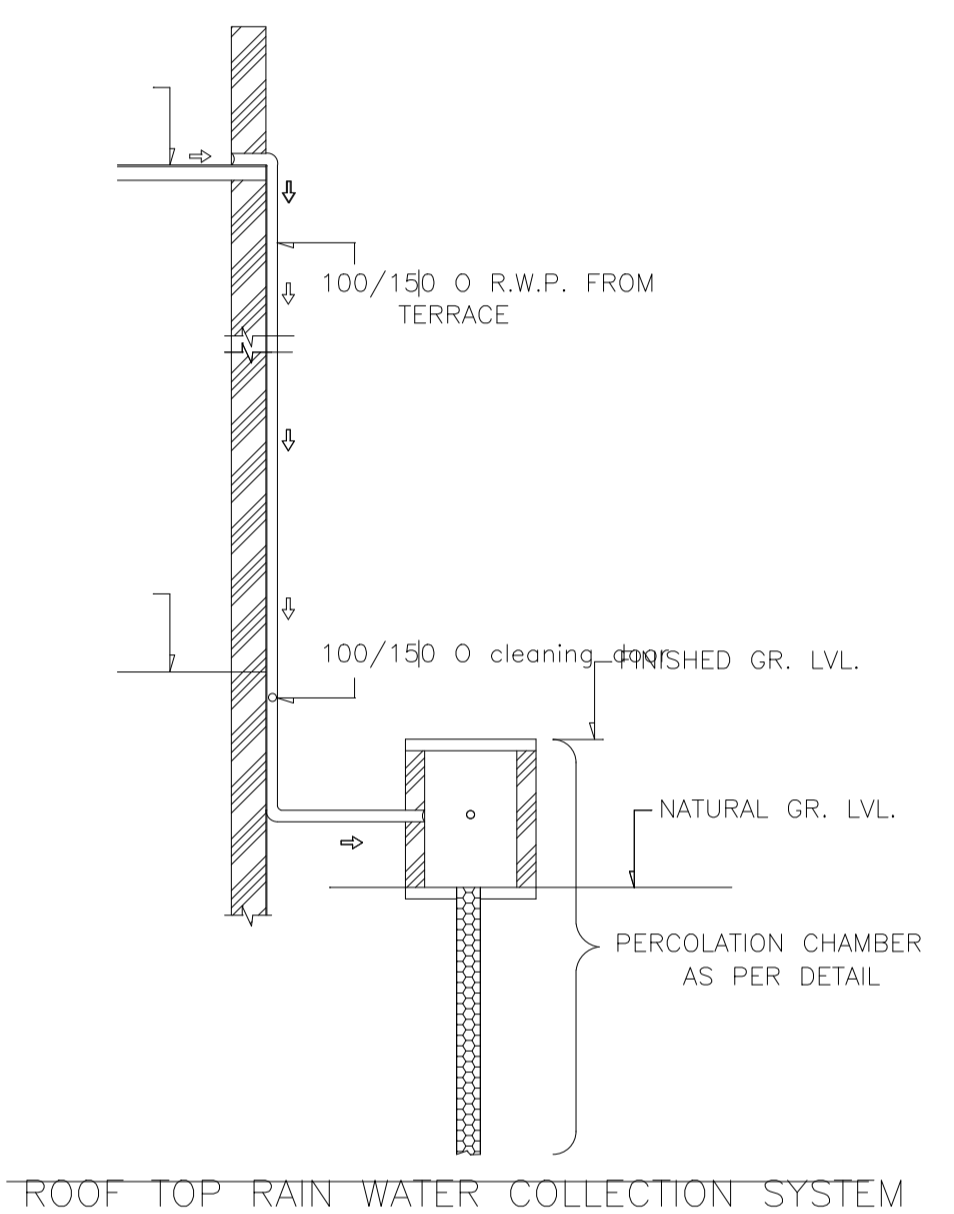
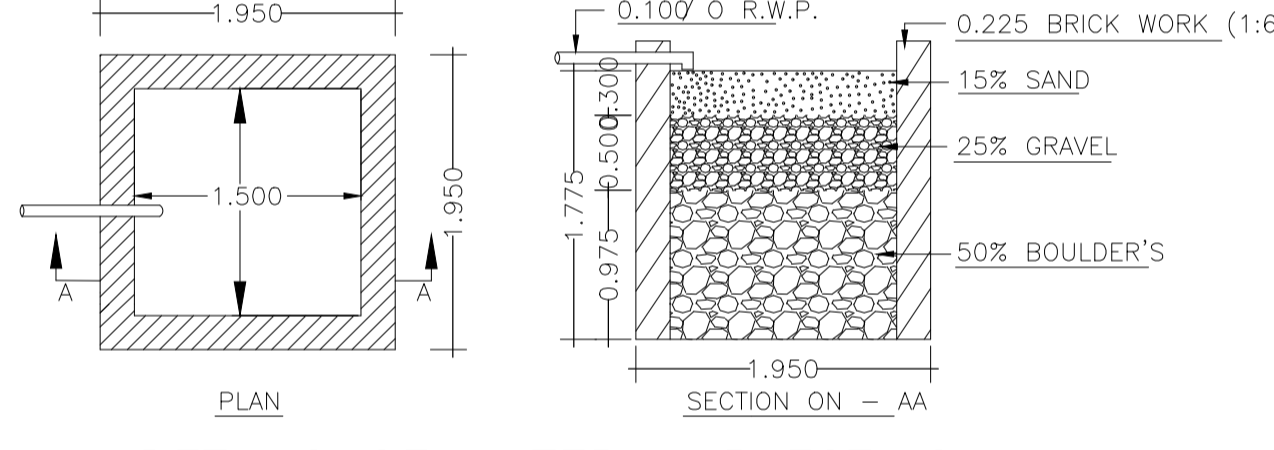
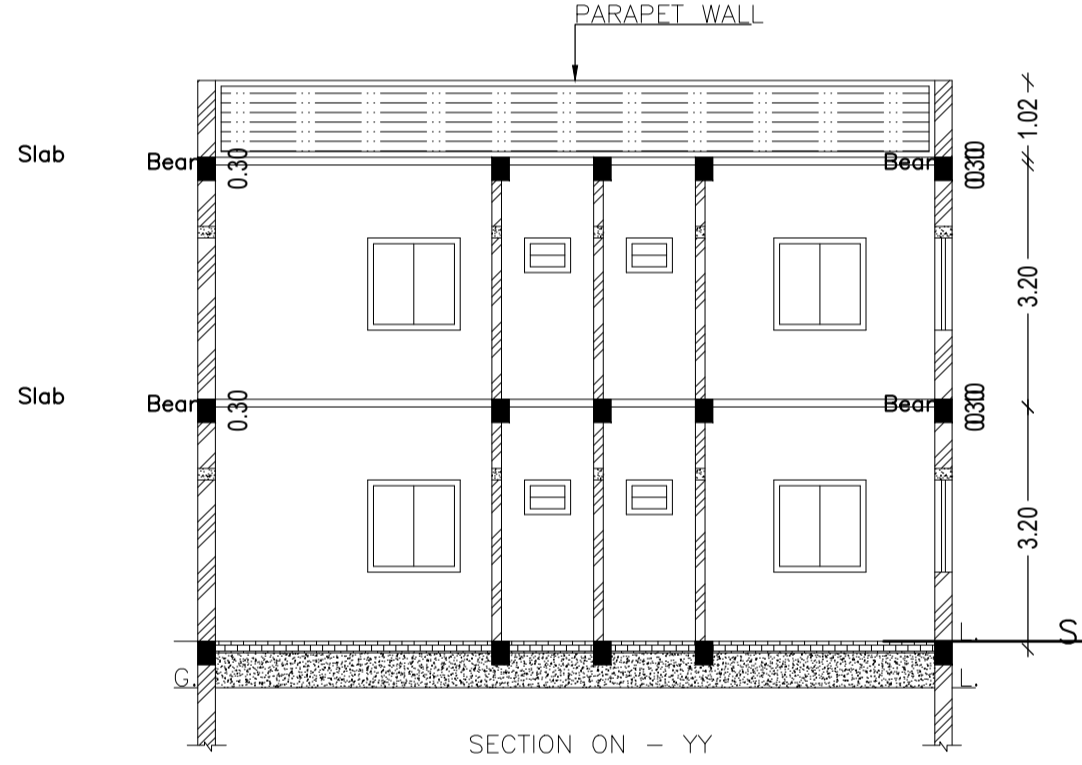
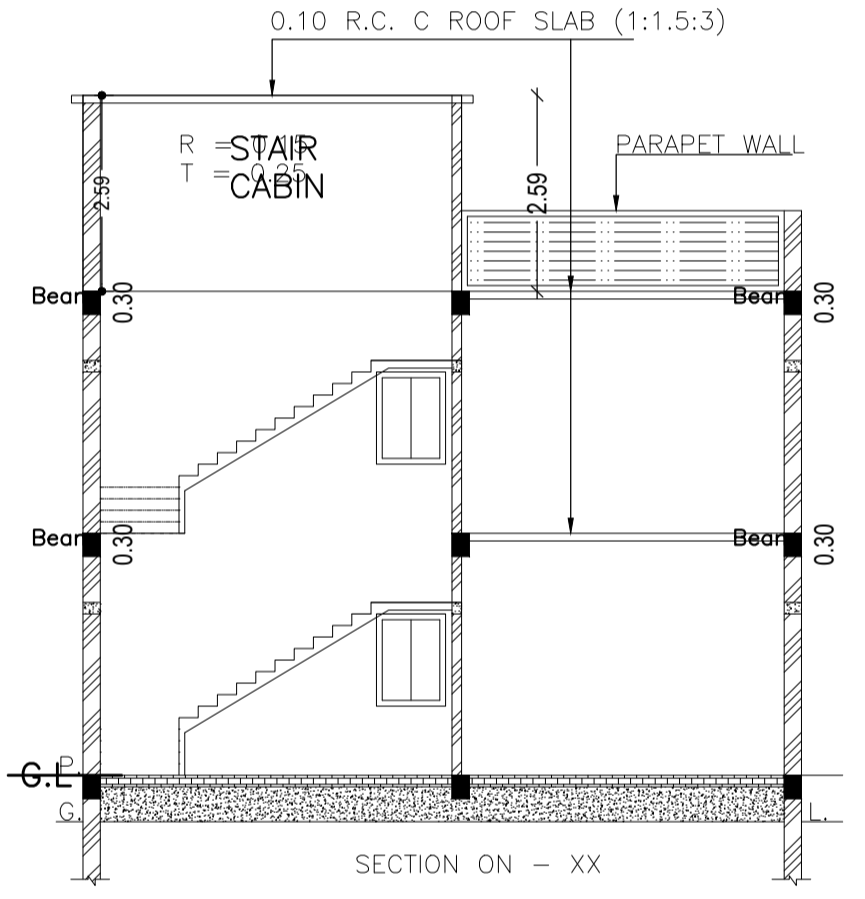
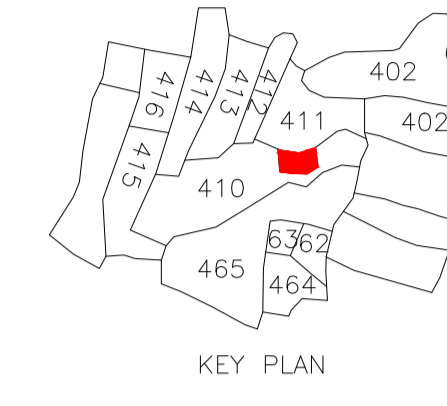
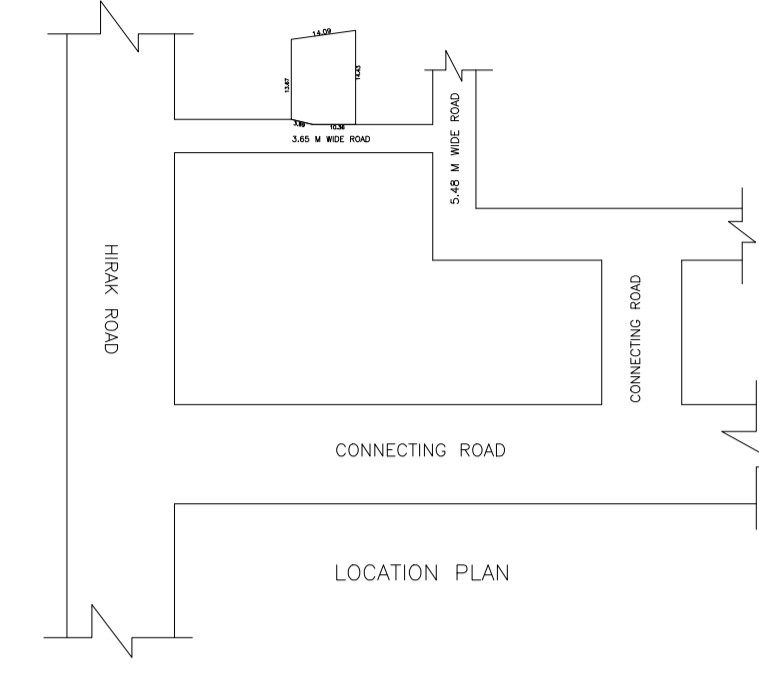
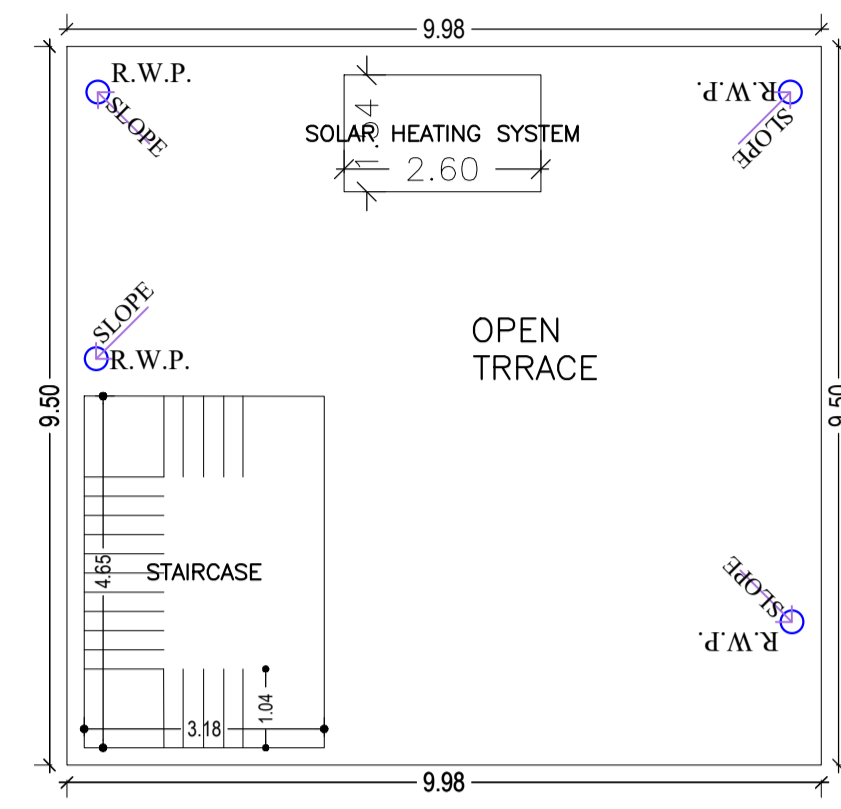
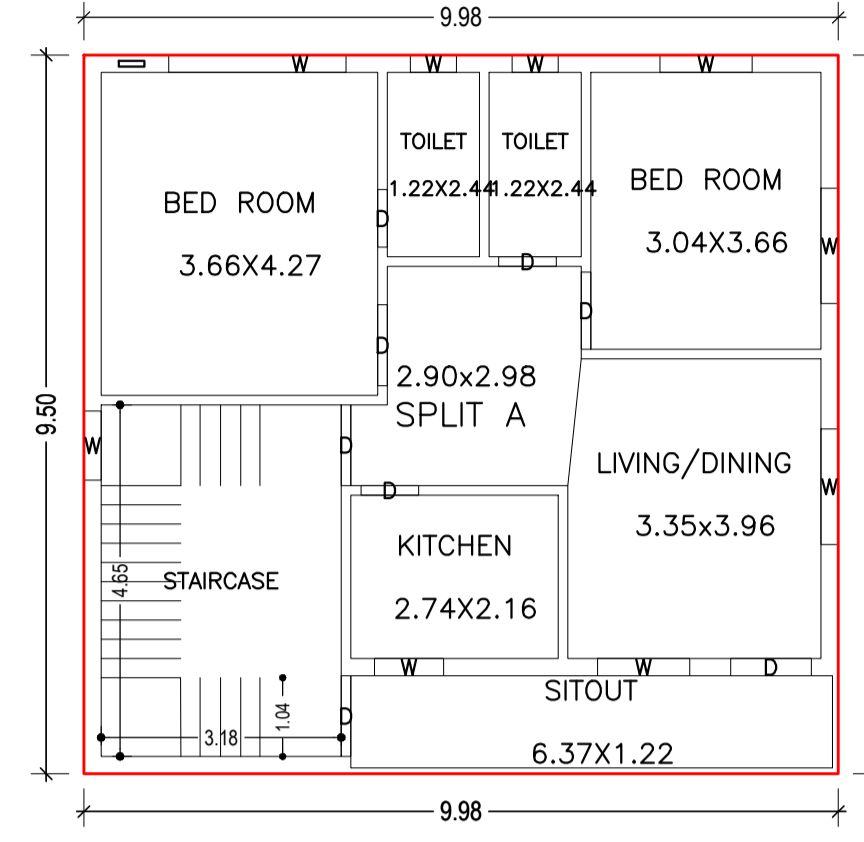
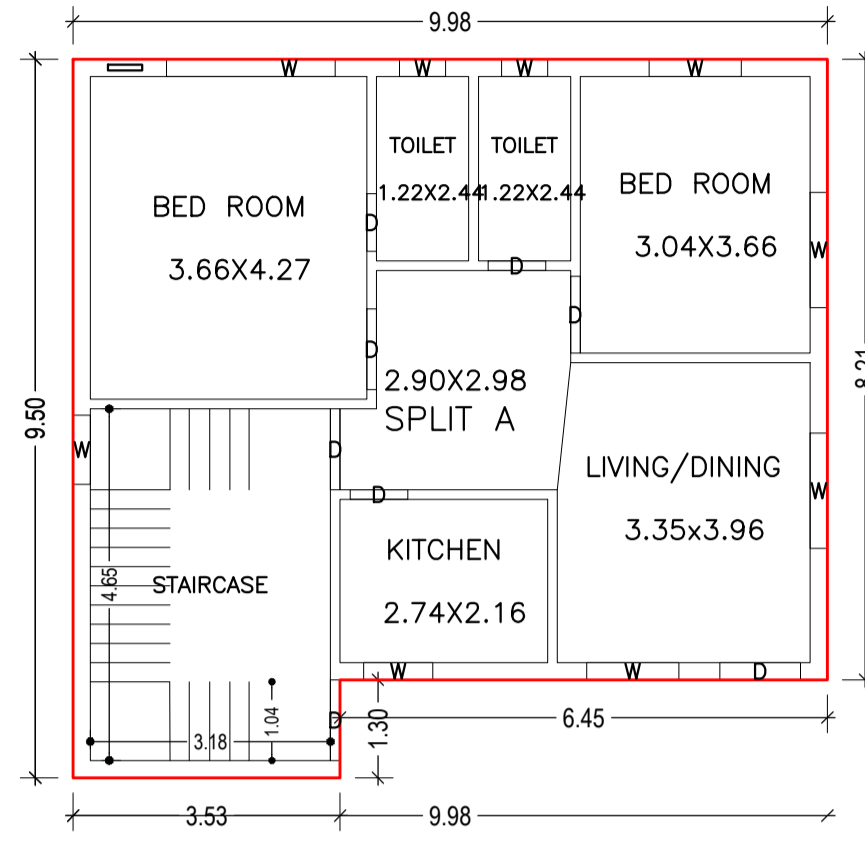

LTP NAME AND SIGNATURE	STRUCTURAL ENG'S NAME AND SIGNATURE	BUILDER NAME AND SIGNATURE	DIGITAL SIGNATURE
Ashish kr singh DMC/ARC/0016/2017			