

AREA STATEMENT	VERSION NO.: 1.0.53
DHANBAD MUNICIPAL CORPORATION	VERSION DATE: 16/10/2020
PROJECT DETAIL:	
Region: JHARKHAND URBAN LOCAL BODIES	Plot Use: Residential
District: DHANBAD	Plot SubUse: Bungalow/ Dwelling / Non Apartment
Authority: DHANBAD MUNICIPAL CORPORATION	PlotNearby/ReligiousStructure: NA
Inward No: DMC/BP/0299/W23/2020	Plot/SubPlot No: NEW - 737 OLD - 828
Application Type: General Proposal	North: Plot No. - SMT JASHODA DEVI
Project Type: Building Permission	South: Plot No. - NEW PLOT NO - 824
Nature of Development: New	East: Plot No - NEW PLOT NO - 737
Location of Development Area: Old Area	West: Road Width - 6.1 M WIDE ROAD
AREA DETAILS:	
AREA OF PLOT (Minimum)	(A) 158.46
NET AREA OF PLOT(Gross Plot Area - Deduction from Gross Plot area)	(A-Deductions) 158.46
Deduction for Balance Plot Area(from Gross Plot Area)	
Common Plot	10.95
Total	10.95
BALANCE AREA OF PLOT(Net Plot Area - Recreational/Amenity space)	(A-Deductions) 147.51
PLOT AREA FOR COVERAGE(Net Plot Area)	(A-Deductions) 158.46
Plot Area for FAR (Net Plot Area + Road Widening Area)	(A-Deductions) 158.46
COVERAGE CHECK	
Permissible Coverage area ( 70.00 % )	110.92
Proposed Coverage Area ( 60.05 % )	95.15
Total Prop. Coverage Area ( 60.05 % )	95.15
Balance coverage area ( 9.95 % )	15.77
FAR CHECK	
Perm. FAR Area ( 2.50 )	396.15
Total Perm. FAR area	396.15
Residential FAR	197.98
Proposed FAR Area	197.98
Total Proposed FAR Area	197.98
Consumed FAR (Factor)	1.25
Balance FAR Area	198.17
BUILT UP AREA CHECK	
Total Proposed BuiltUp Area	197.98
ARCHITECT (Regd)	Ashish kr singh
ENGINEER (Regd)	
SUPERVISOR (Regd)	
OWNER (Regd)	SMT MANJU DEVI
DEVELOPMENT AUTHORITY	LOCAL BODY

COLOR INDEX	
PLOT BOUNDARY	Black
ABUTTING ROAD	Green
PROPOSED CONSTRUCTION	Red
COMMON PLOT	Yellow
ROAD WIDENING AREA	Blue
EXISTING (To be retained)	Orange
EXISTING (To be demolished)	Light Blue

Buildingwise Floor FAR Details				
Floor Name	Building Name A (A)		Total	
	Proposed Built Up Area (Sq.mt.)	Proposed FAR Area (Sq.mt.)	Total Proposed Built Up Area (Sq.mt.)	Total FAR Area (Sq.mt.)
Ground Floor	95.15	95.15	95.15	95.15
First Floor	102.83	102.83	102.83	102.83
Terrace Floor	0.00	0.00	0.00	0.00
Total :	197.98	197.98	197.98	197.98

Building USE/SUBUSE Details			
Building Name	Building Use	Building SubUse	Building Structure
A (A)	Residential	Bungalow/ Dwelling / Non Apartment	Non-Highrise

Building :A (A)					
Floor Name	Total Built Up Area (Sq.mt.)	Proposed FAR Area (Sq.mt.)		Total Consumed Additional FAR Area (Sq.mt.)	Tnmt (No.)
		Resi.	Other		
Ground Floor	95.15	95.15	95.15	95.15	01
First Floor	102.83	102.83	102.83	102.83	00
Terrace Floor	0.00	0.00	0.00	0.00	00
Total :	197.98	197.98	197.98	197.98	01
Total Number of Same Buildings :	1				
Total :	197.98	197.98	197.98	197.98	01

SCHEDULE OF DOOR:				
BUILDING NAME	NAME	LENGTH	HEIGHT	NOS
A (A)	D	0.59	2.10	02
A (A)	D	0.76	2.10	02
A (A)	D	0.91	2.10	08
A (A)	D	0.95	2.10	01
A (A)	D	1.07	2.10	02
A (A)	D	1.14	2.10	02
A (A)	D	1.22	2.10	01

SCHEDULE OF WINDOW/VENTILATION:				
BUILDING NAME	NAME	LENGTH	HEIGHT	NOS
A (A)	W	0.61	1.20	04
A (A)	W	0.85	1.20	02
A (A)	W	0.91	1.20	02
A (A)	W	1.22	1.20	10
A (A)	W	1.52	1.20	02
A (A)	W	1.77	1.20	02

FAR & Tenement Details (Table 4c-1)						
Building	No. of Same Bldg	Total Built Up Area (Sq.mt.)	Proposed FAR Area (Sq.mt.) Resi.	Total FAR Area (Sq.mt.)	Total Consumed Additional FAR Area (Sq.mt.)	Tnmt (No.)
A (A)	1	197.98	197.98	197.98	197.98	01
Grand Total :	1	197.98	197.98	197.98	197.98	01

UnitBUA Table for Building :A (A)						
FLOOR	Name	UnitBUA Type	UnitBUA Area	Carpet Area	No. of Rooms	No. of Tenement
FIRST FLOOR PLAN	SPLIT V	FLAT	0.00	0.00	9	0
GROUND FLOOR PLAN	SPLIT V	FLAT	197.98	197.79	8	1
Total:	-	-	197.98	197.79	17	1

LTP NAME AND SIGNATURE	STRUCTURAL ENG'S NAME AND SIGNATURE	BUILDER NAME AND SIGNATURE	DIGITAL SIGNATURE
Ashish kr singh DMC/ARC/0016/2017			

Proposal Basic Information	
Proposal File No.	DMC/BP/0299/W23/2020
Owner Name	SMT MANJU DEVI
Khata No	NEW - 29,OLD -26
Plot No	NEW - 737,OLD -828
Village Name	Sabalpur
Use	Residential
SubUse	Bungalow/ Dwelling / Non Apartment

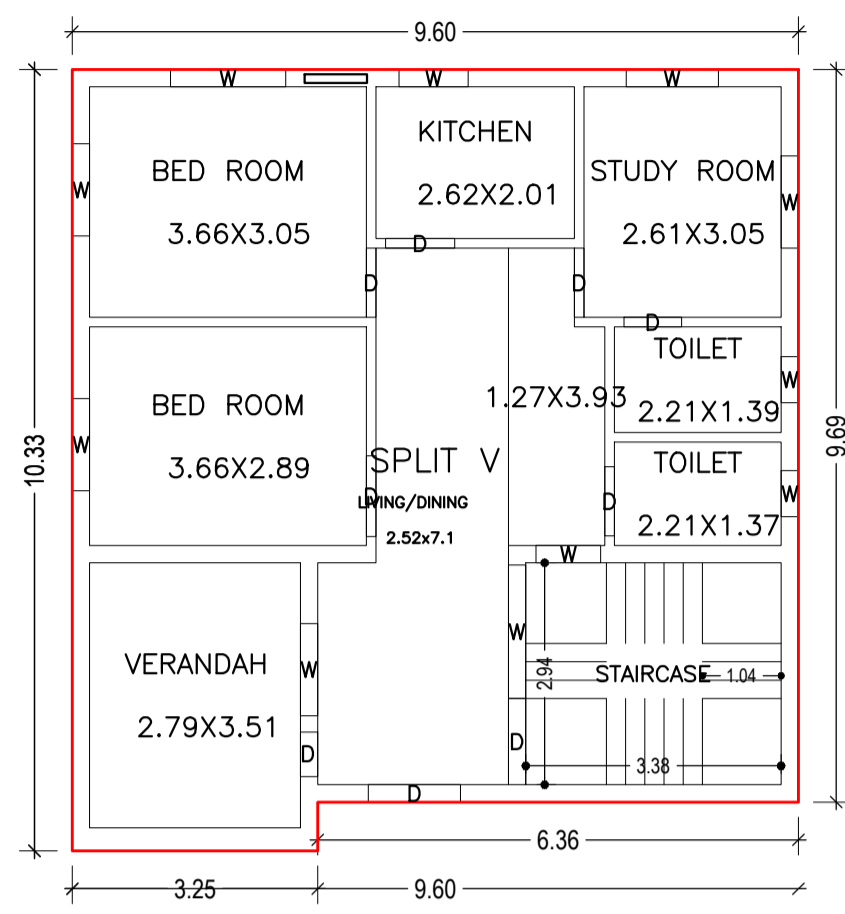

GROUND FLOOR PLAN (Proposed) (SCALE 1:100)

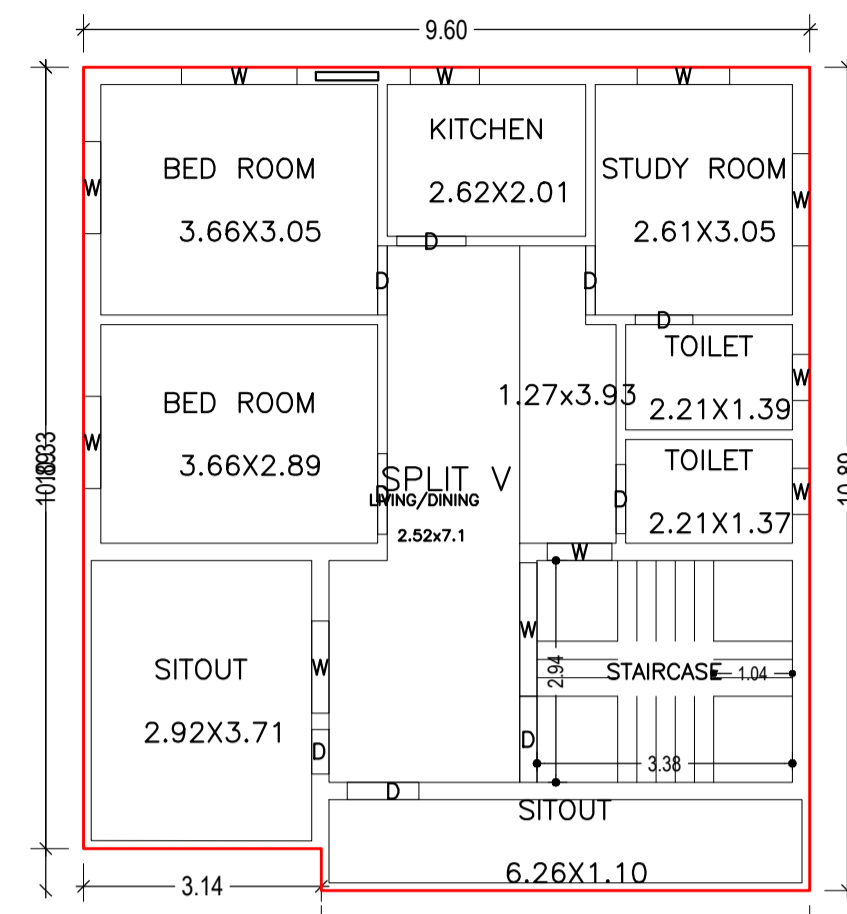

FIRST FLOOR PLAN (Proposed) (SCALE 1:100)

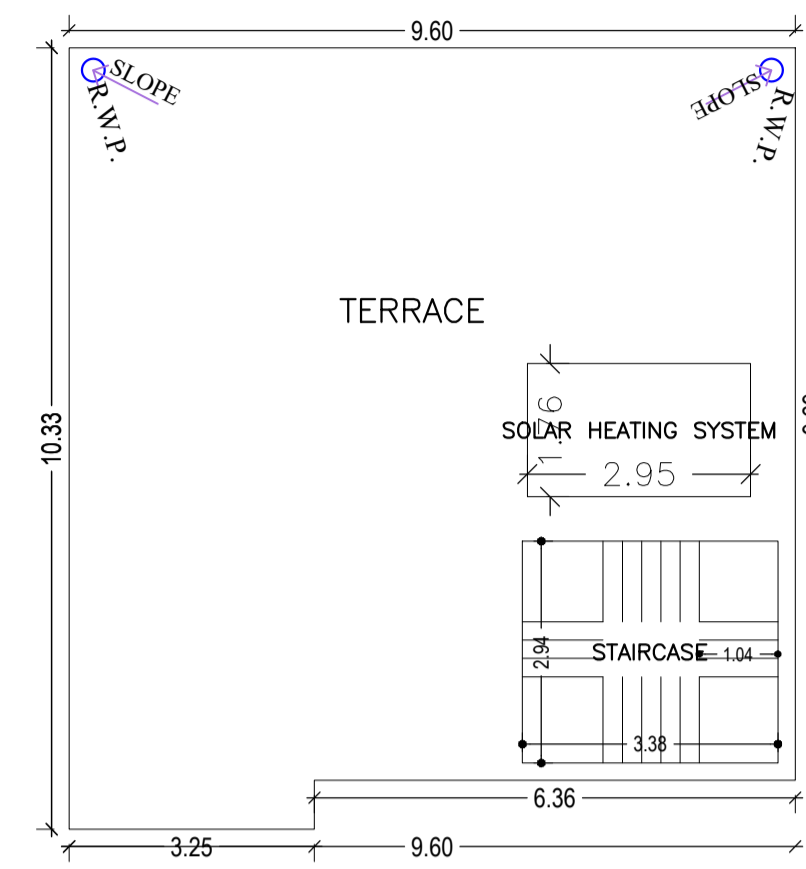

TERRACE FLOOR PLAN (SCALE 1:100)

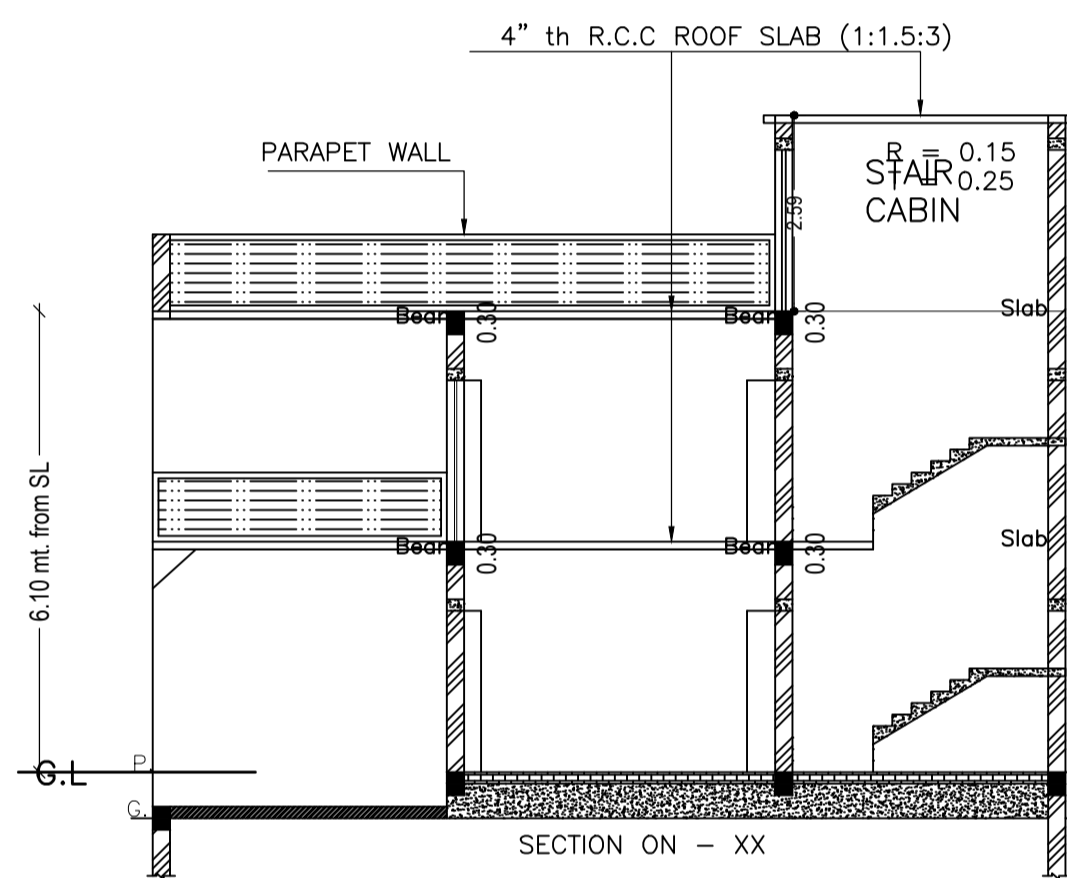
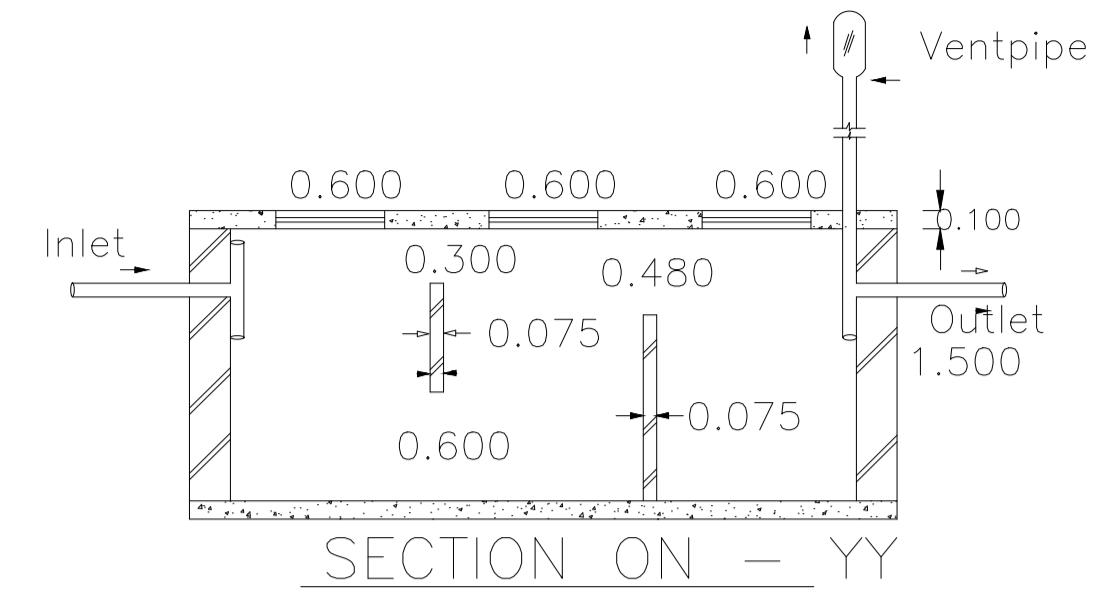

SECTION ON - XX

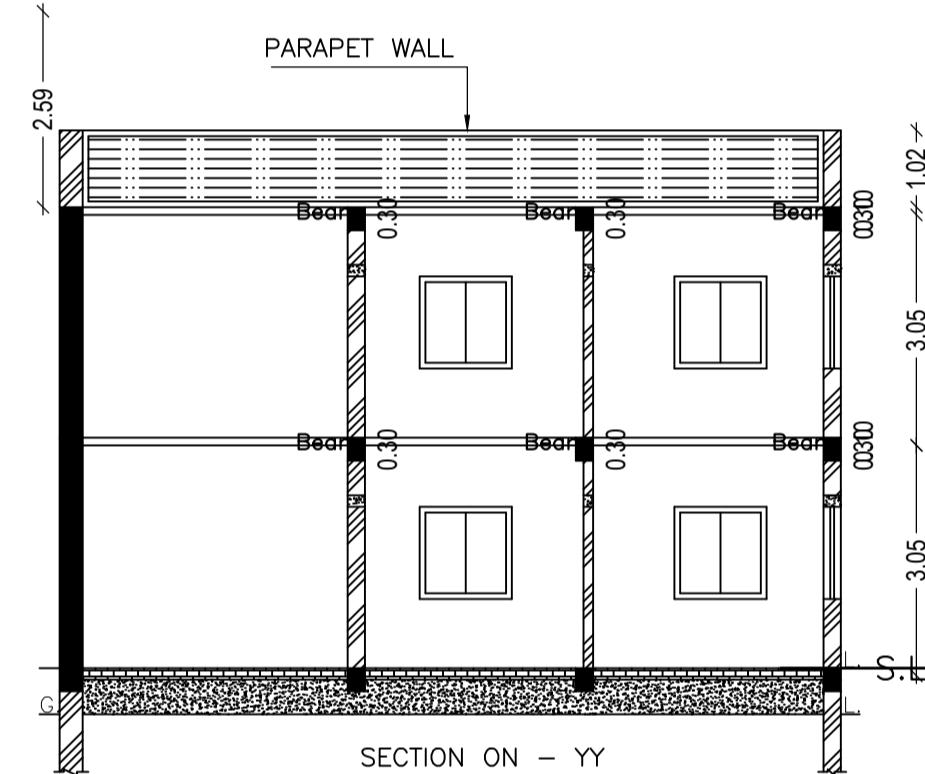

SECTION ON - YY

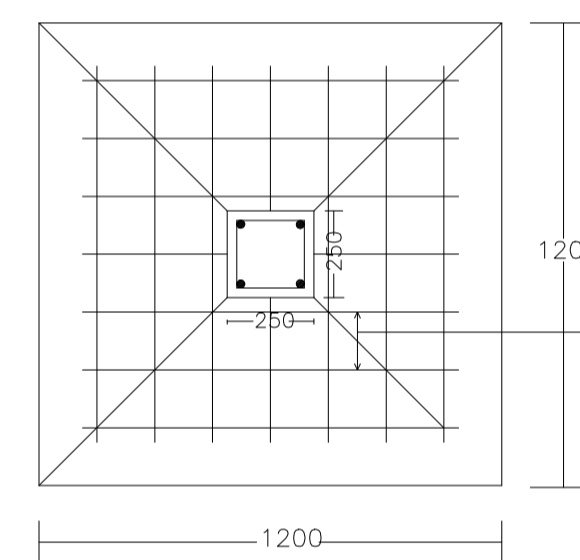

PLAN

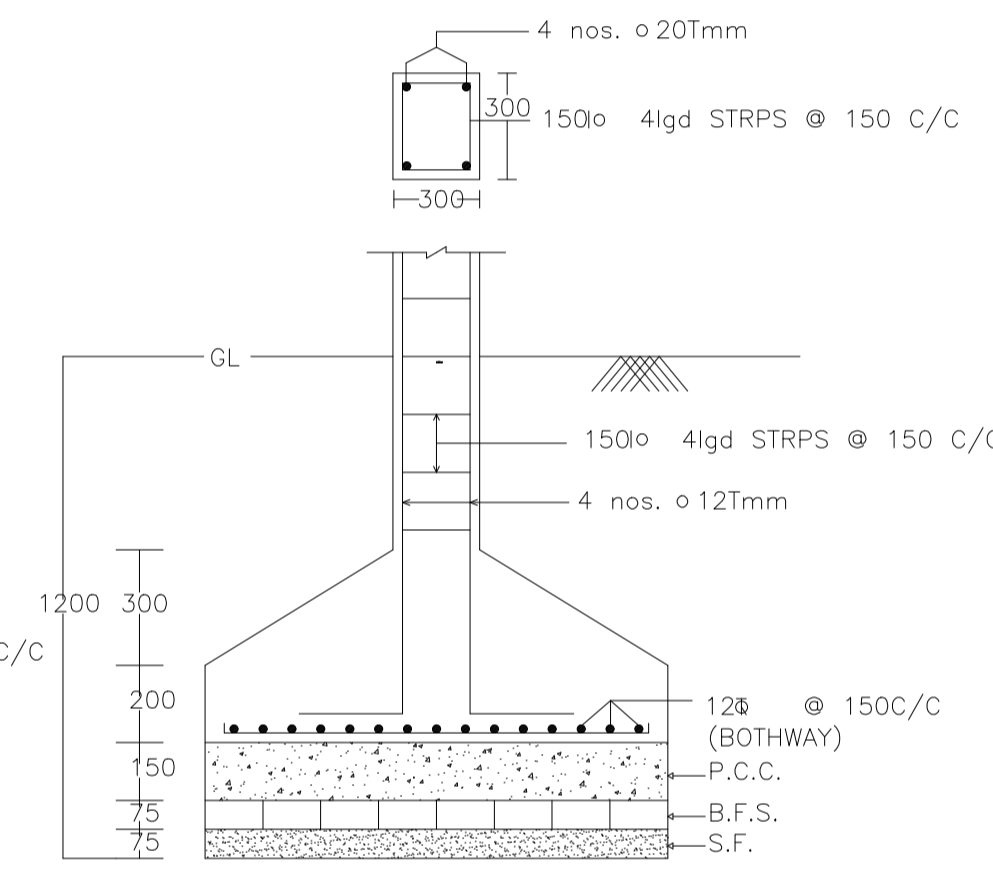

SECTION

DETAIL OF COLUMNS

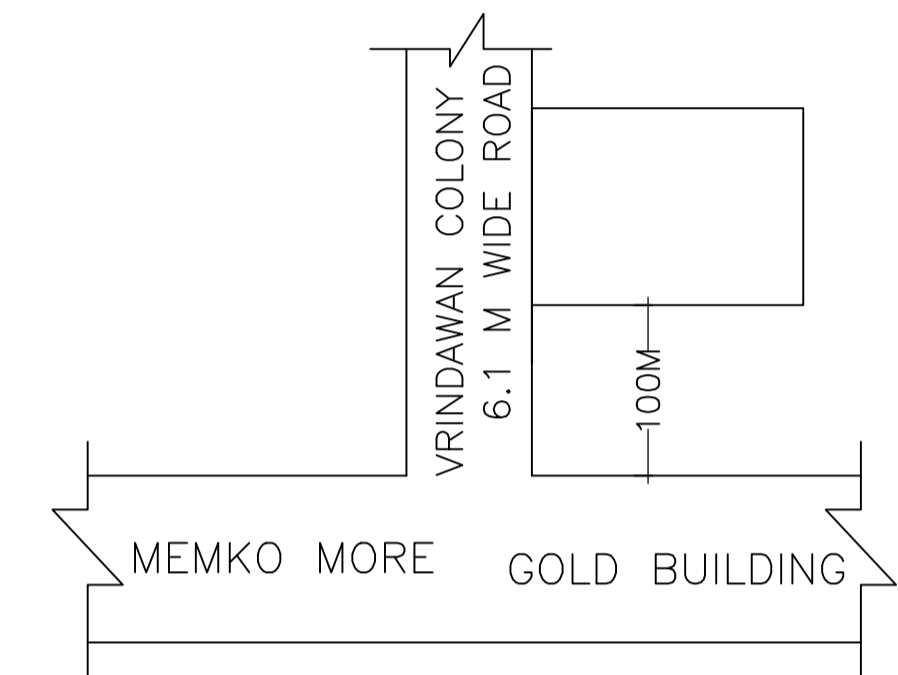

LOCATION PLAN

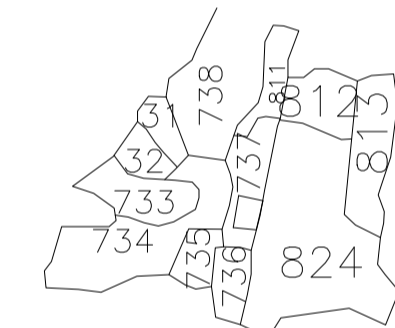

KEY PLAN

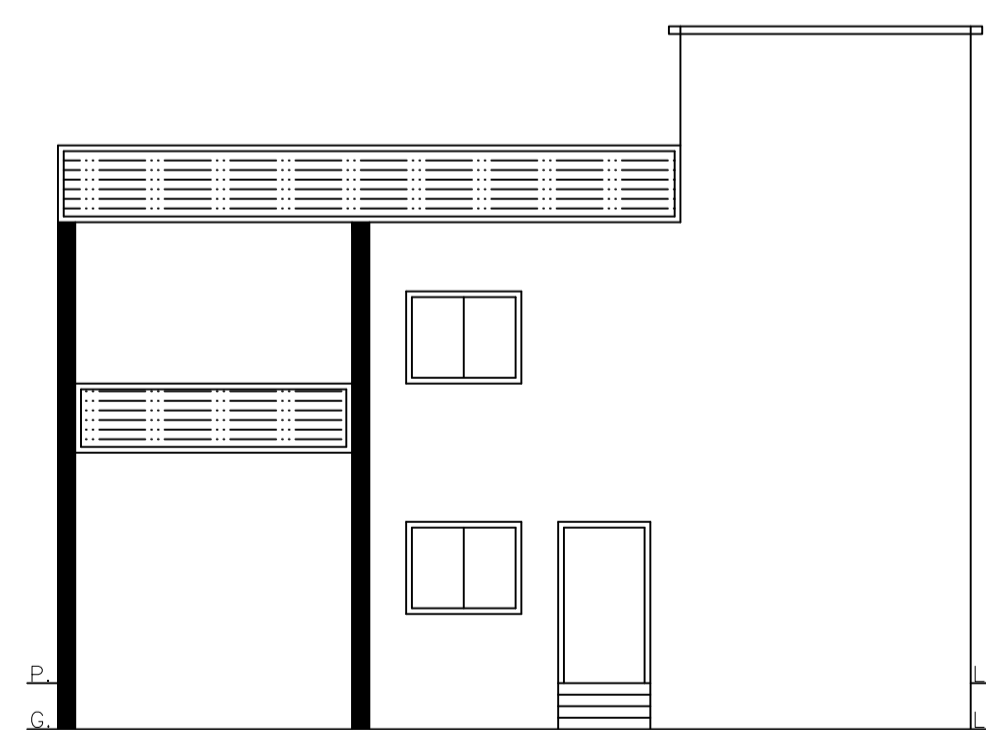

FRONT ELEVATION

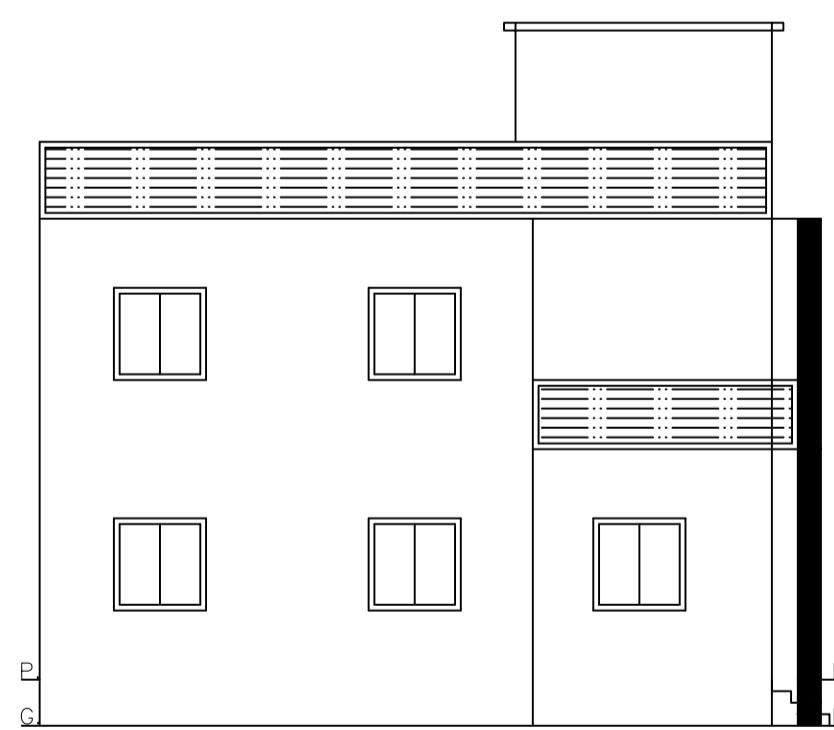

LEFT SIDE ELEVATION

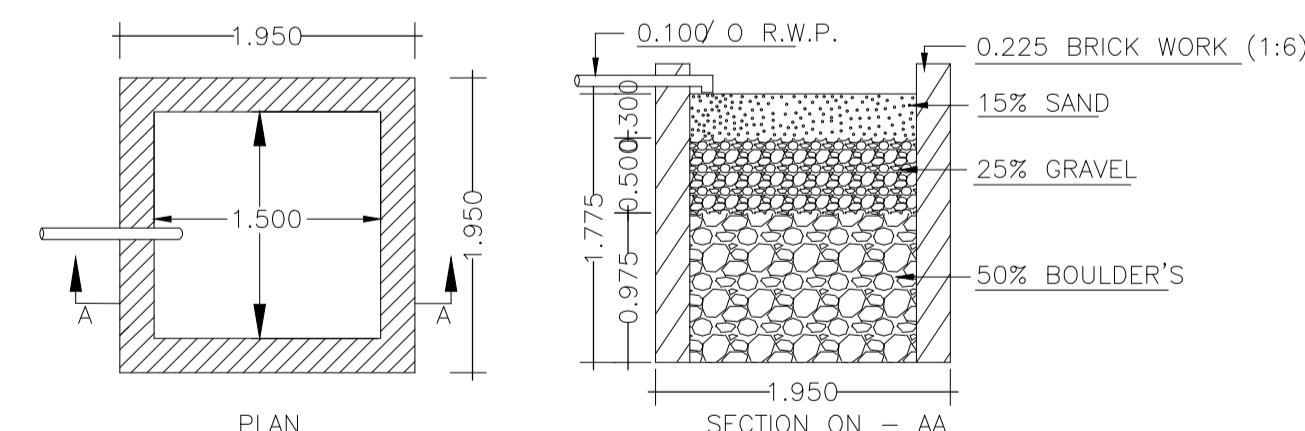

DETAILS OF WATER HARVESTING

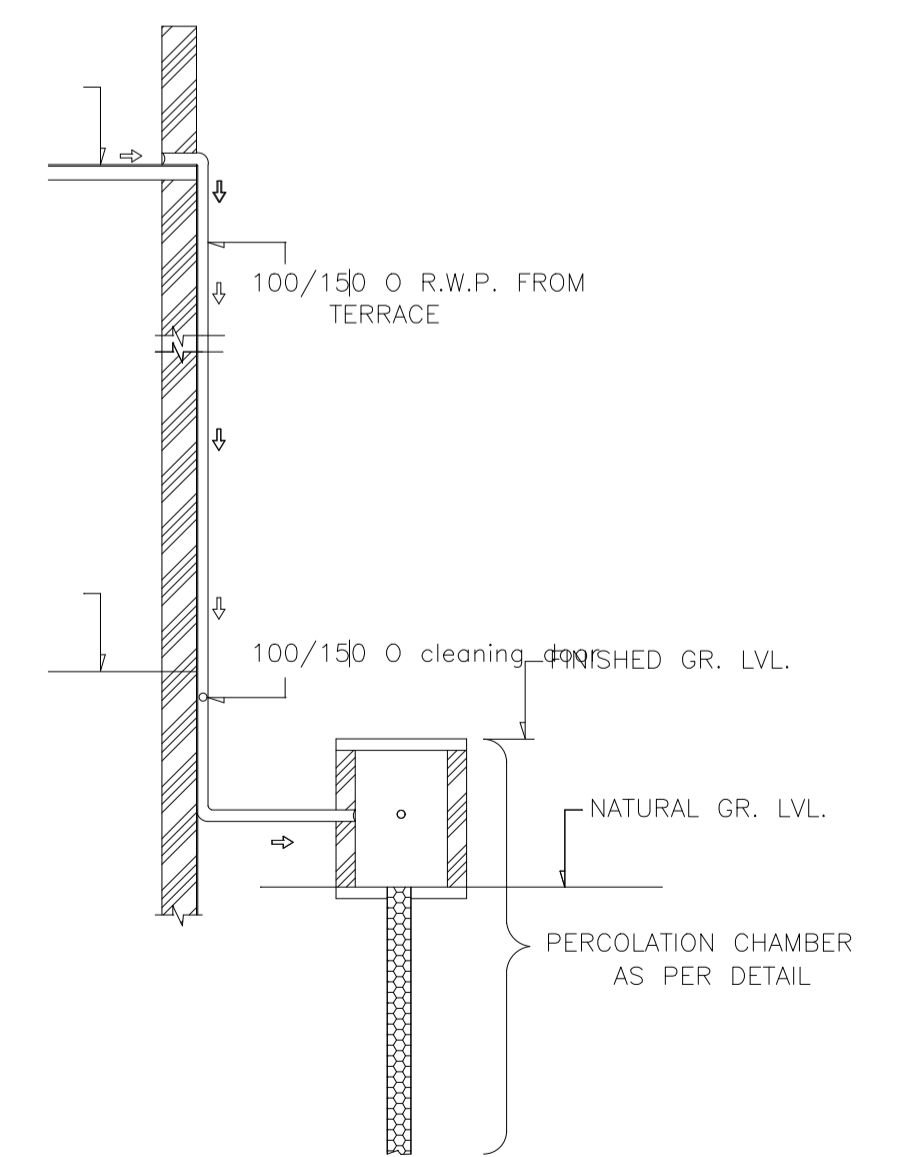

ROOF TOP RAIN WATER COLLECTION SYSTEM

LTP NAME AND SIGNATURE	STRUCTURAL ENG'S NAME AND SIGNATURE	BUILDER NAME AND SIGNATURE	DIGITAL SIGNATURE
Ashish kr singh DMC/ARC/0016/2017			