

SITE PLAN SCALE : 1:96 (1"=8'-0")

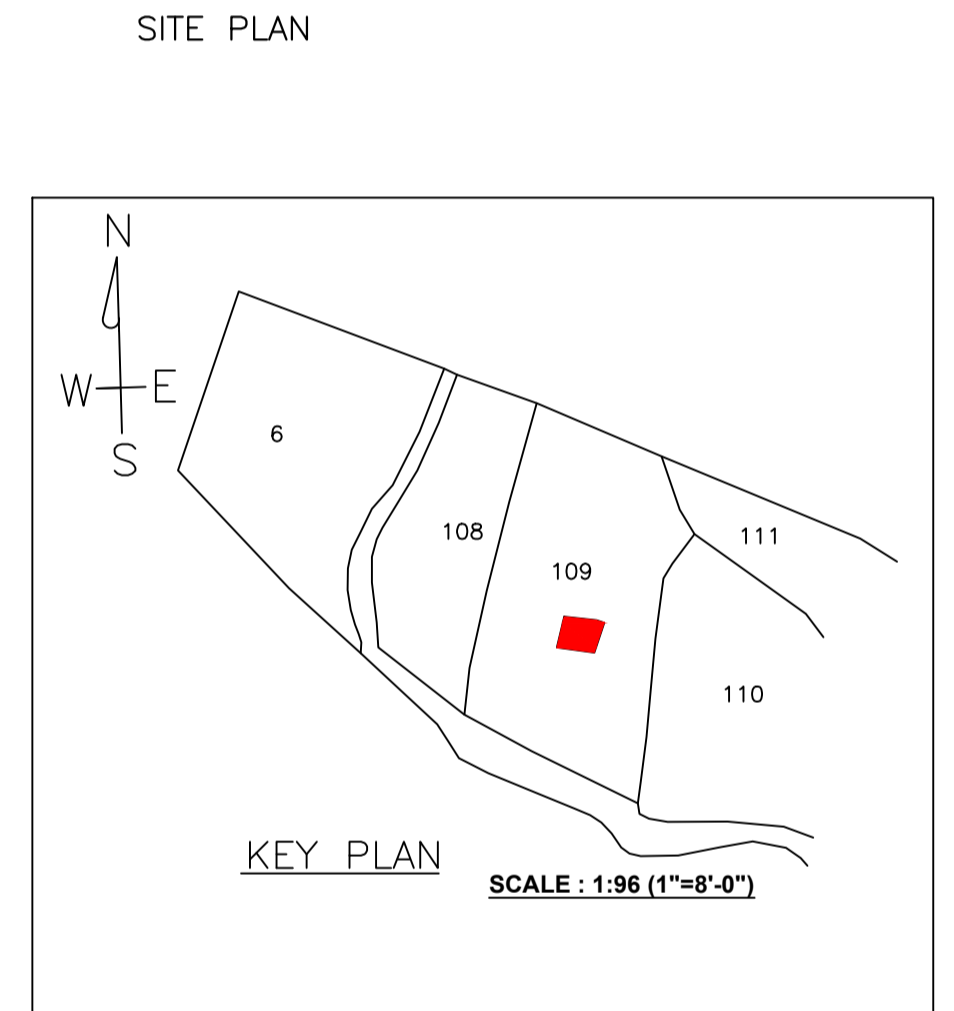

KEY PLAN SCALE : 1:96 (1"=8'-0")

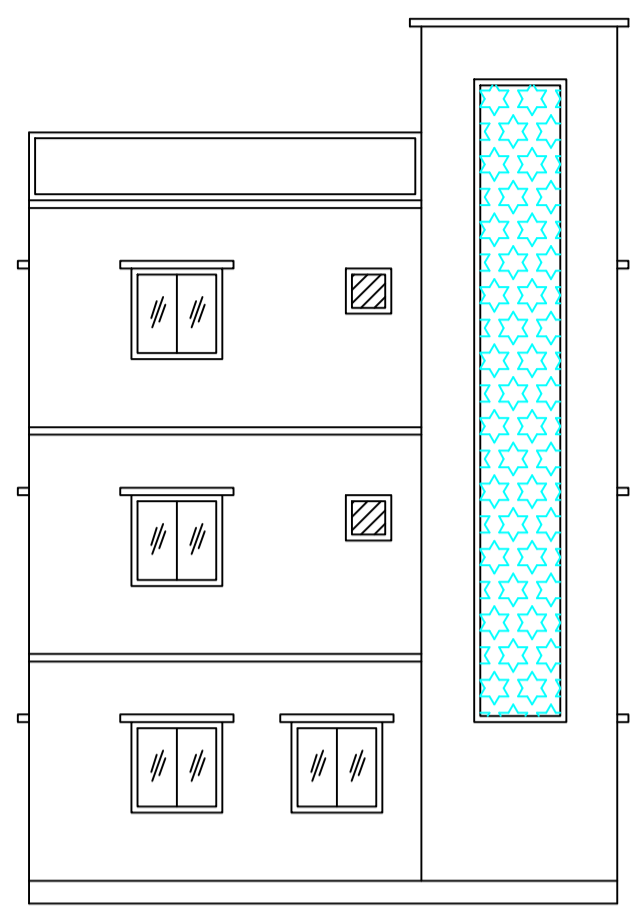

RIGHT SIDE ELEVATION SCALE : 1:96 (1"=8'-0")

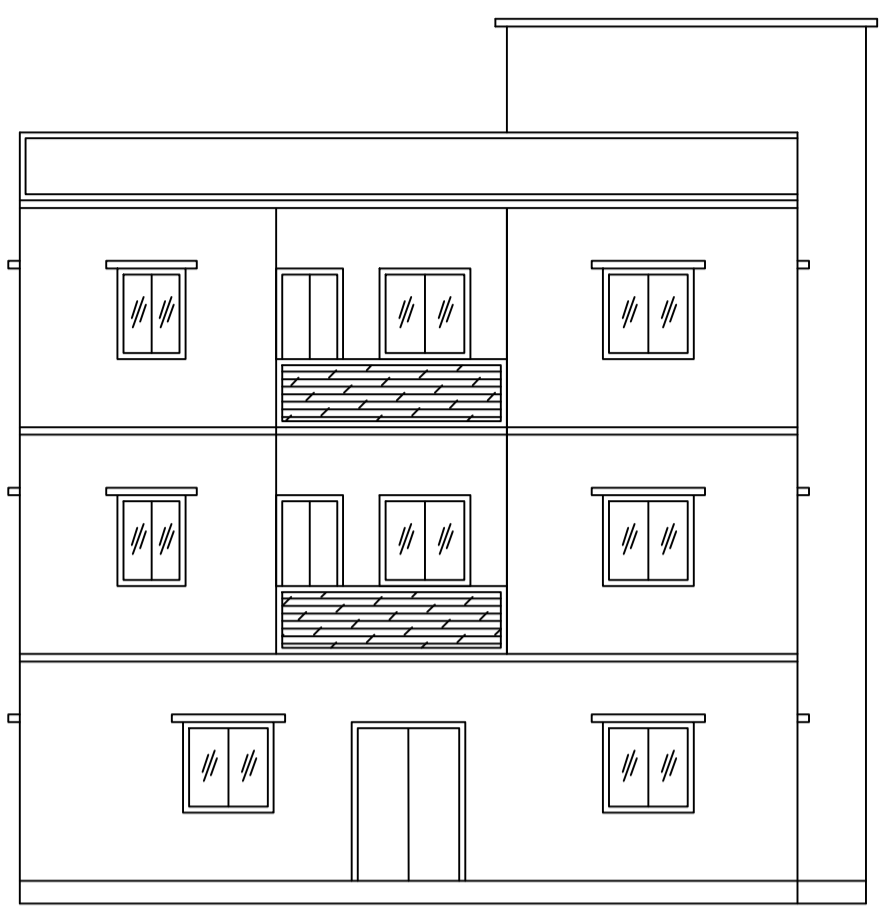

FRONT ELEVATION SCALE : 1:96 (1"=8'-0")

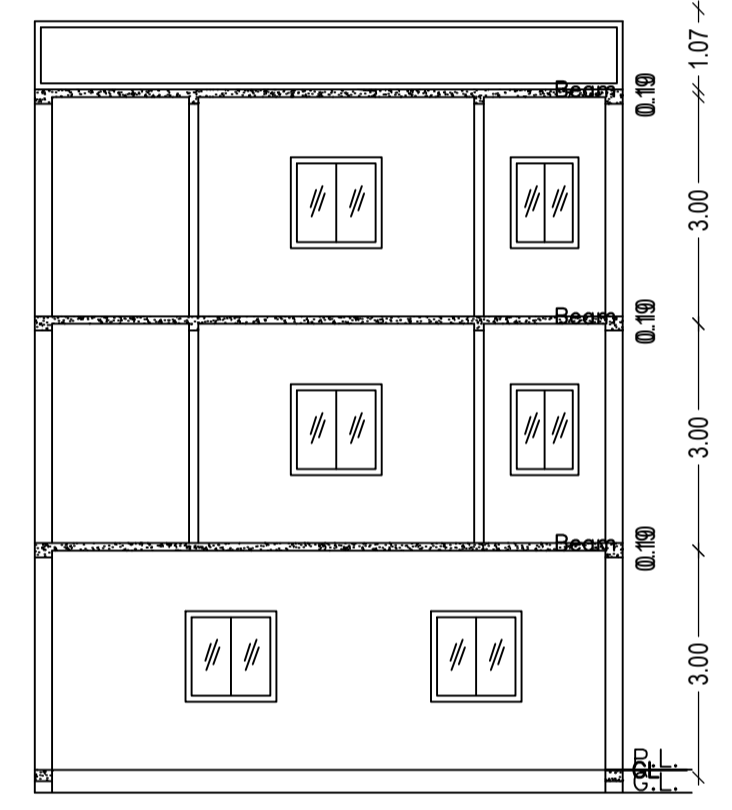

SECTION ON Y-Y SCALE : 1:96 (1"=8'-0")

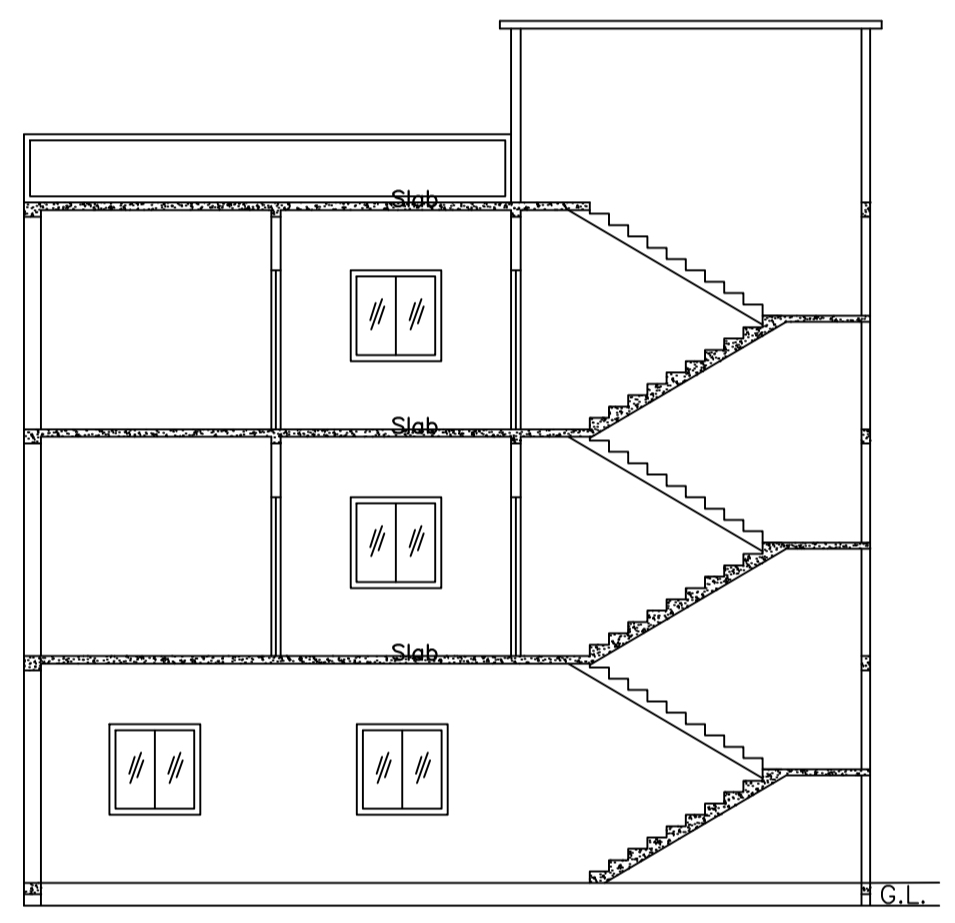

SECTION ON X-X

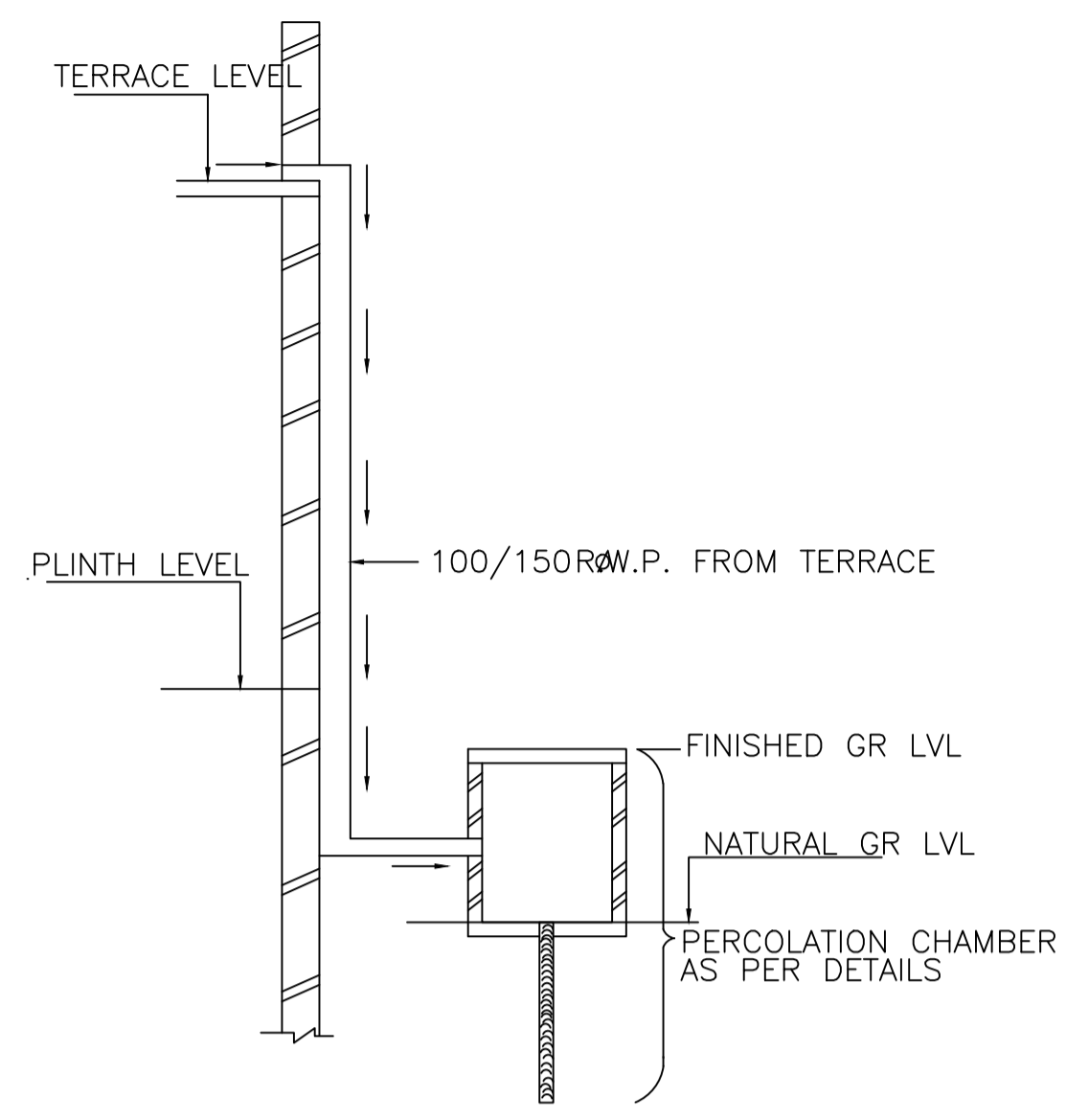

ROOF TOP RAIN WATER COLLECTION SYSTEM SCALE : 1:96 (1"=8'-0")

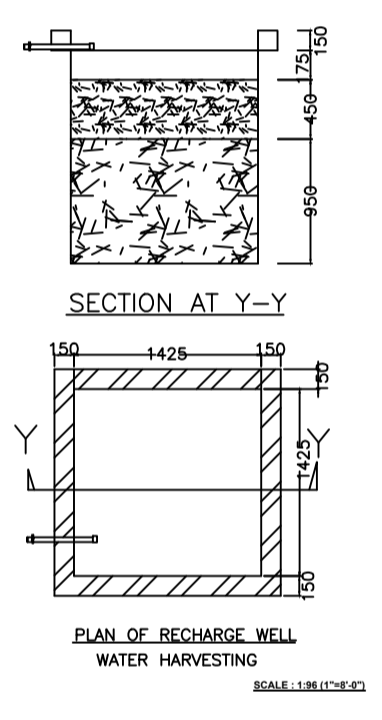

PLAN OF RECHARGE WELL WATER HARVESTING SCALE: 1:100

Building :A (SMT MEENA DEVI)

| Floor Name | Total Built Up Area (Sq.mt.) | Proposed FAR Area (Sq.mt.) Resi. | Total FAR Area (Sq.mt.) | Total Consumed Additional FAR Area (Sq.mt.) | Tnmt (No.) |
|----------------------------------|------------------------------|----------------------------------|-------------------------|---|------------|
| Ground Floor | 82.39 | 82.39 | 82.39 | 82.39 | 01 |
| First Floor | 82.39 | 82.39 | 82.39 | 82.39 | 00 |
| Second Floor | 82.39 | 82.39 | 82.39 | 82.39 | 00 |
| Terrace Floor | 0.00 | 0.00 | 0.00 | 0.00 | 00 |
| Total : | 247.17 | 247.17 | 247.17 | 247.17 | 01 |
| Total Number of Same Buildings : | 1 | | | | |
| Total : | 247.17 | 247.17 | 247.17 | 247.17 | 01 |

SCHEDULE OF DOOR:

| BUILDING NAME | NAME | LENGTH | HEIGHT | NOS |
|--------------------|------|--------|--------|-----|
| A (SMT MEENA DEVI) | D | 0.88 | 2.10 | 02 |
| A (SMT MEENA DEVI) | D | 0.90 | 2.10 | 04 |
| A (SMT MEENA DEVI) | D | 0.99 | 2.10 | 02 |
| A (SMT MEENA DEVI) | D | 1.10 | 2.10 | 07 |
| A (SMT MEENA DEVI) | D | 1.50 | 2.10 | 01 |

SCHEDULE OF WINDOW/VENTILATION:

| BUILDING NAME | NAME | LENGTH | HEIGHT | NOS |
|--------------------|------|--------|--------|-----|
| A (SMT MEENA DEVI) | W | 0.60 | 1.20 | 03 |
| A (SMT MEENA DEVI) | W | 0.90 | 1.20 | 06 |
| A (SMT MEENA DEVI) | W | 1.18 | 1.20 | 03 |
| A (SMT MEENA DEVI) | W | 1.20 | 1.20 | 15 |

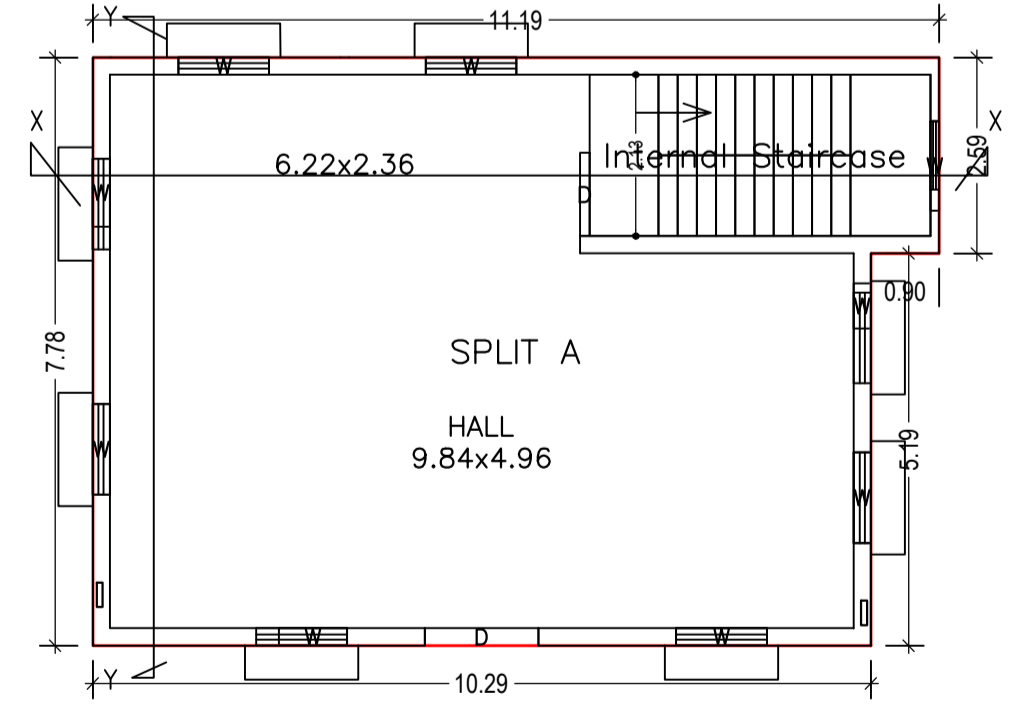

GROUND FLOOR PLAN (Proposed) (SCALE 1:100)

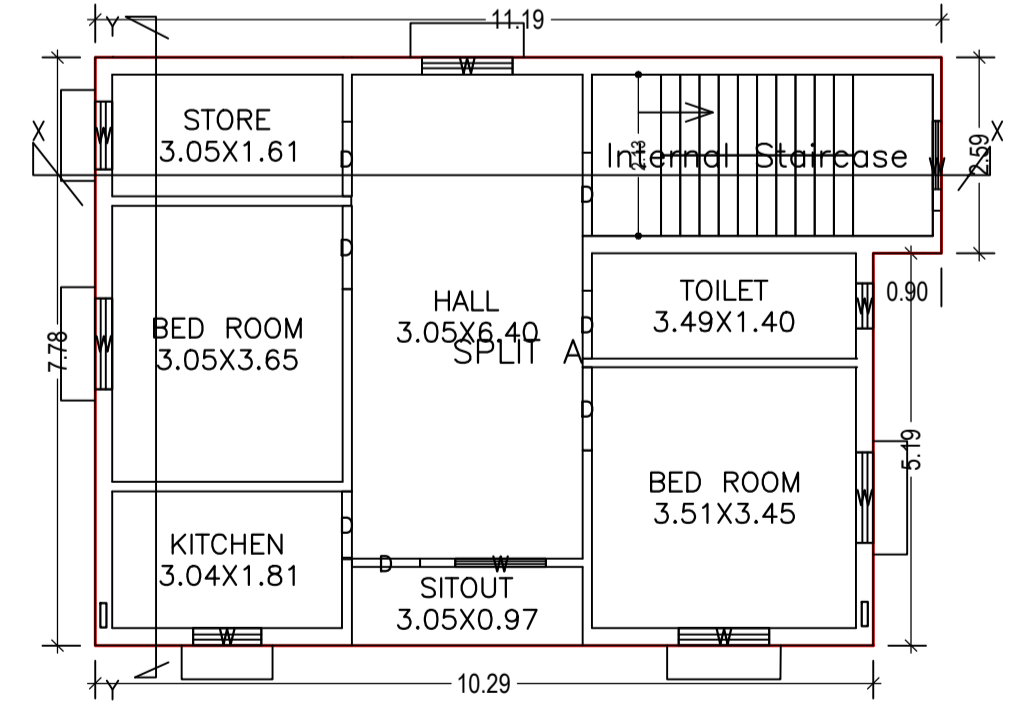

TYPICAL - 1, 2 FLOOR PLAN (Proposed) (SCALE 1:100)

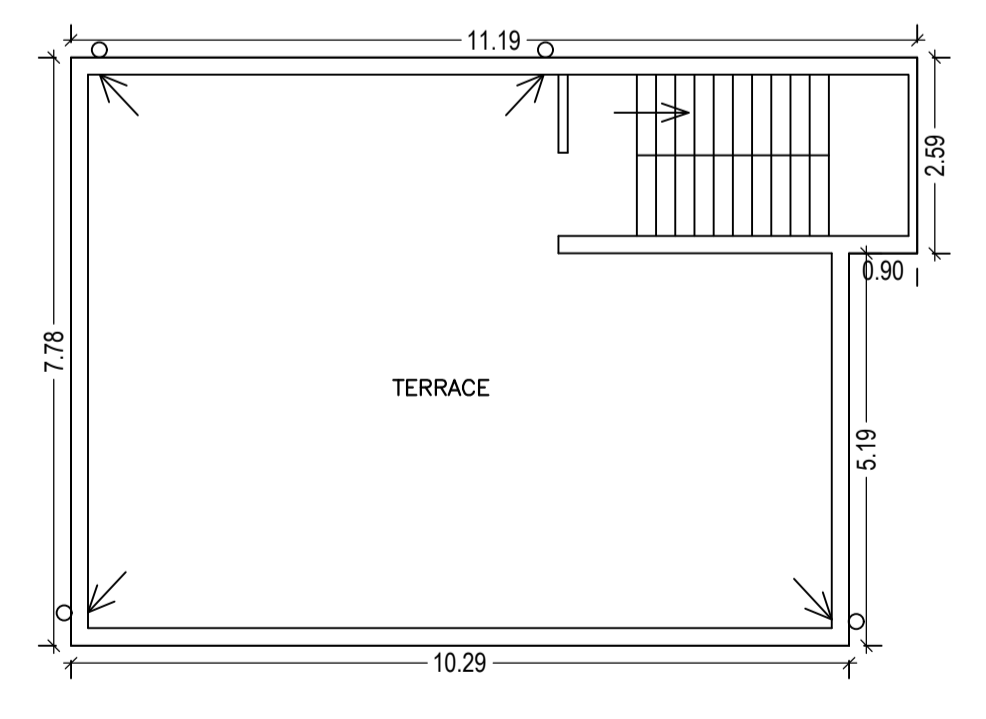

TERRACE FLOOR PLAN (SCALE 1:100)

Proposal Basic Information

| | |
|-------------------|------------------------------------|
| Proposal File No. | DMC/BP/0078/W20/2020 |
| Owner Name | MEENA DEVI |
| Khata No | 28 NEW-38 |
| Plot No | 109, NEW-145 |
| Village Name | Baramuri |
| Use | Residential |
| SubUse | Bungalow/ Dwelling / Non Apartment |

AREA STATEMENT

| AREA DETAILS: | AREA | SQ.MT. |
|--|---------------------|--------|
| AREA OF PLOT (Minimum) | (A) | 152.71 |
| NET AREA OF PLOT(Gross Plot Area - Deduction from Gross Plot area) | (A-Deductions) | 152.71 |
| Deduction for Balance Plot Area(from Gross Plot Area) | | |
| Common Plot | | 41.74 |
| Total | | 41.74 |
| BALANCE AREA OF PLOT(Net Plot Area - Recreational/Amenity space) | (A-Deductions) | 110.97 |
| PLOT AREA FOR COVERAGE(Net Plot Area) | (A-Deductions) | 152.71 |
| Plot Area for FAR (Net Plot Area + Road Widening Area) | (A-Deductions) | 152.71 |
| COVERAGE CHECK | | |
| Permissible Coverage area (70.00 %) | | 106.90 |
| Proposed Coverage Area (53.95 %) | | 82.39 |
| Total Prop. Coverage Area (53.95 %) | | 82.39 |
| Balance coverage area (16.05 %) | | 24.51 |
| FAR CHECK | | |
| Perm. FAR Area (1.80) | | 274.88 |
| Total Perm. FAR area | | 274.88 |
| Residential FAR | | 247.17 |
| Proposed FAR Area | | 247.17 |
| Total Proposed FAR Area | | 247.17 |
| Consumed FAR (Factor) | | 1.62 |
| Balance FAR Area | | 27.71 |
| BUILT UP AREA CHECK | | |
| Total Proposed BuiltUp Area | | 247.17 |
| ARCHITECT (Regd) | RAJEEV RANJAN SINGH | |
| ENGINEER (Regd) | | |
| SUPERVISOR (Regd) | | |
| OWNER (Regd) | MEENA DEVI | |
| DEVELOPMENT AUTHORITY | LOCAL BODY | |

COLOR INDEX

| | |
|-----------------------------|------------|
| PLOT BOUNDARY | Black |
| ABUTTING ROAD | Green |
| PROPOSED CONSTRUCTION | Red |
| COMMON PLOT | Yellow |
| ROAD WIDENING AREA | Blue |
| EXISTING (To be retained) | Orange |
| EXISTING (To be demolished) | Light Blue |

Buildingwise Floor FAR Details

| Floor Name | Building Name A (SMT MEENA DEVI) | | Total | |
|---------------|----------------------------------|----------------------------|---------------------------------------|-------------------------|
| | Proposed Built Up Area (Sq.mt.) | Proposed FAR Area (Sq.mt.) | Total Proposed Built Up Area (Sq.mt.) | Total FAR Area (Sq.mt.) |
| Ground Floor | 82.39 | 82.39 | 82.39 | 82.39 |
| First Floor | 82.39 | 82.39 | 82.39 | 82.39 |
| Second Floor | 82.39 | 82.39 | 82.39 | 82.39 |
| Terrace Floor | 0.00 | 0.00 | 0.00 | 0.00 |
| Total : | 247.17 | 247.17 | 247.17 | 247.17 |

Building USE/SUBUSE Details

| Building Name | Building Use | Building SubUse | Building Structure |
|--------------------|--------------|----------------------------|--------------------|
| A (SMT MEENA DEVI) | Residential | Residential Bldg/Apartment | Non-Highrise |

FAR & Tenement Details (Table 4c-1)

| Building | No. of Same Bldg | Total Built Up Area (Sq.mt.) | Proposed FAR Area (Sq.mt.) Resi. | Total FAR Area (Sq.mt.) | Total Consumed Additional FAR Area (Sq.mt.) | Tnmt (No.) |
|--------------------|------------------|------------------------------|----------------------------------|-------------------------|---|------------|
| A (SMT MEENA DEVI) | 1 | 247.17 | 247.17 | 247.17 | 247.17 | 01 |
| Grand Total : | 1 | 247.17 | 247.17 | 247.17 | 247.17 | 01 |

UnitBUA Table for Building :A (SMT MEENA DEVI)

| FLOOR | Name | UnitBUA Type | UnitBUA Area | Carpet Area | No. of Rooms | No. of Tenement |
|---------------------------|---------|--------------|--------------|-------------|--------------|-----------------|
| GROUND FLOOR PLAN | SPLIT A | FLAT | 247.17 | 247.02 | 1 | 1 |
| TYPICAL - 1, 2 FLOOR PLAN | SPLIT A | FLAT | 0.00 | 0.00 | 7 | 0 |
| Total: | - | - | 247.17 | 247.02 | 15 | 1 |

| | | | |
|--|-------------------------------------|----------------------------|-------------------|
| LTP NAME AND SIGNATURE RAJEEV RANJAN SINGH DMC/ENG/0032/2017 | STRUCTURAL ENG'S NAME AND SIGNATURE | BUILDER NAME AND SIGNATURE | DIGITAL SIGNATURE |
|--|-------------------------------------|----------------------------|-------------------|

| Proposal Basic Information | |
|----------------------------|------------------------------------|
| Proposal File No. | DMC/BP/0078/W20/2020 |
| Owner Name | MEENA DEVI |
| Khata No | 28 NEW-38 |
| Plot No | 109, NEW-145 |
| Village Name | Baramuri |
| Use | Residential |
| SubUse | Bungalow/ Dwelling / Non Apartment |

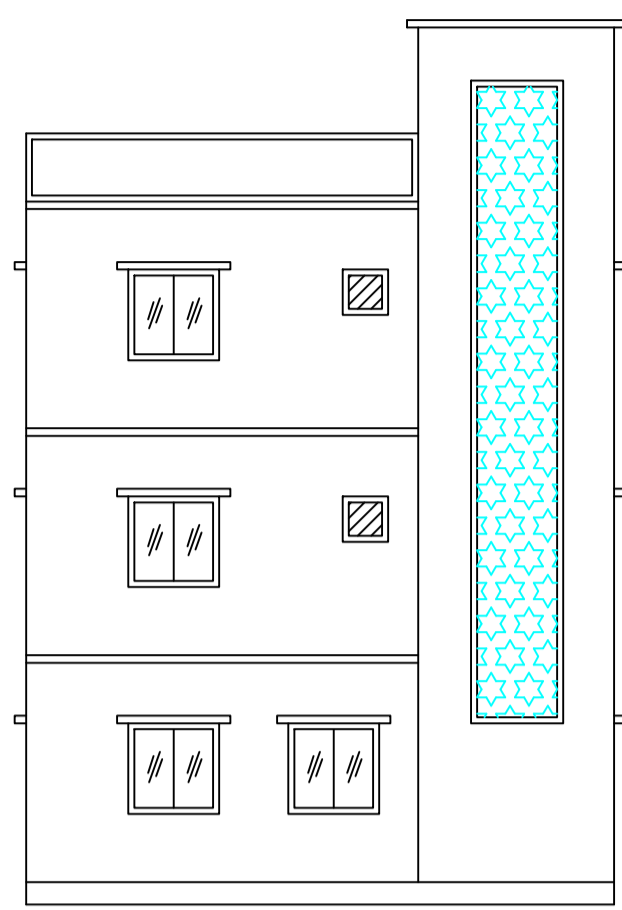

RIGHT SIDE ELEVATION
SCALE : 1:96 (1"=8'-0")

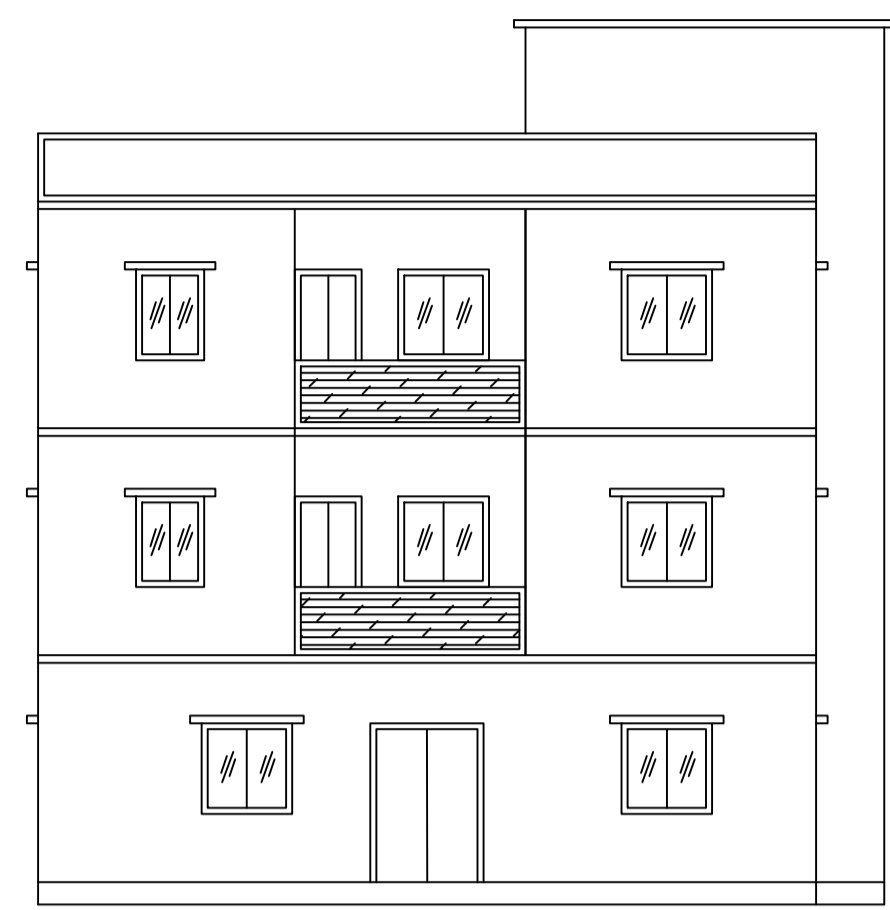

FRONT ELEVATION
SCALE : 1:96 (1"=8'-0")

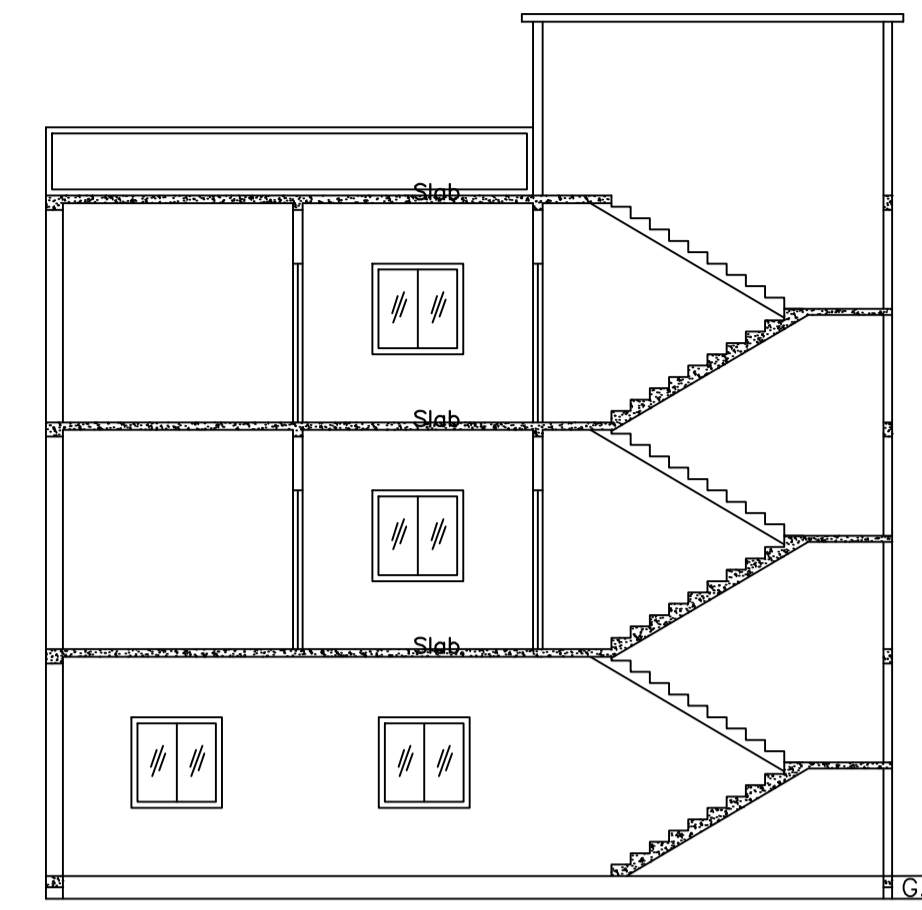

SECTION ON X-X

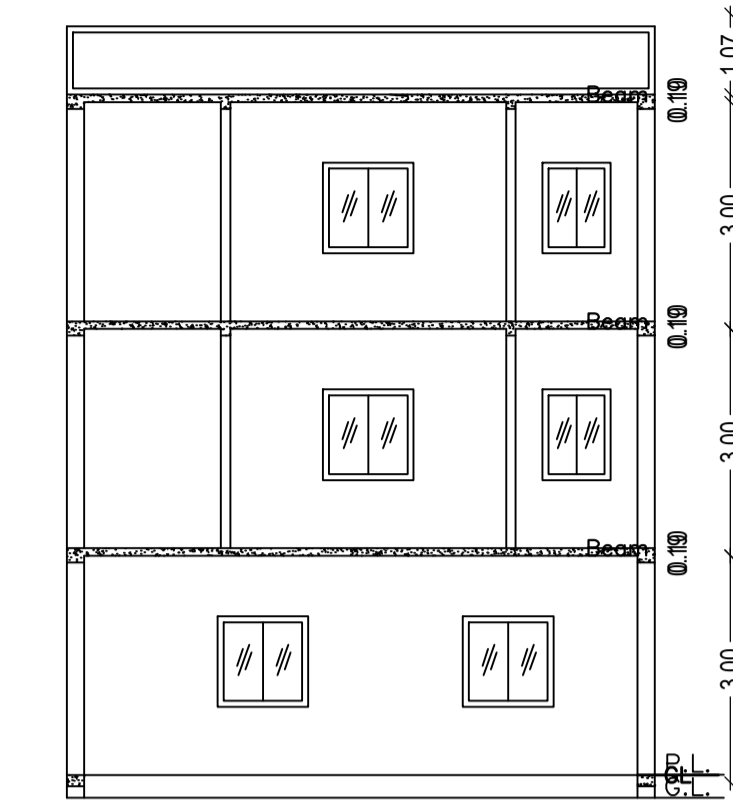

SECTION ON Y-Y
SCALE : 1:96 (1"=8'-0")

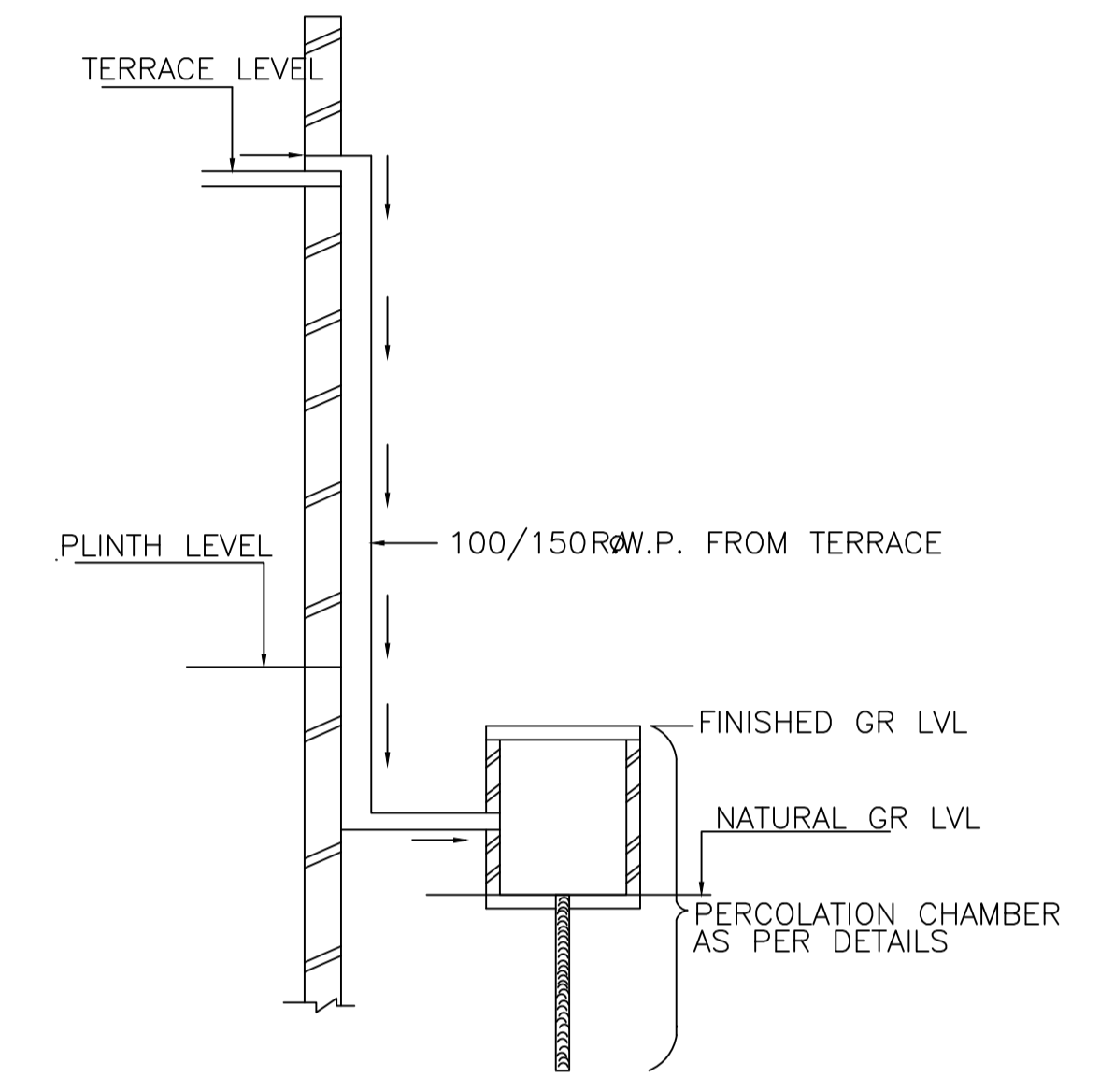

ROOF TOP RAIN WATER COLLECTION SYSTEM
SCALE : 1:96 (1"=8'-0")

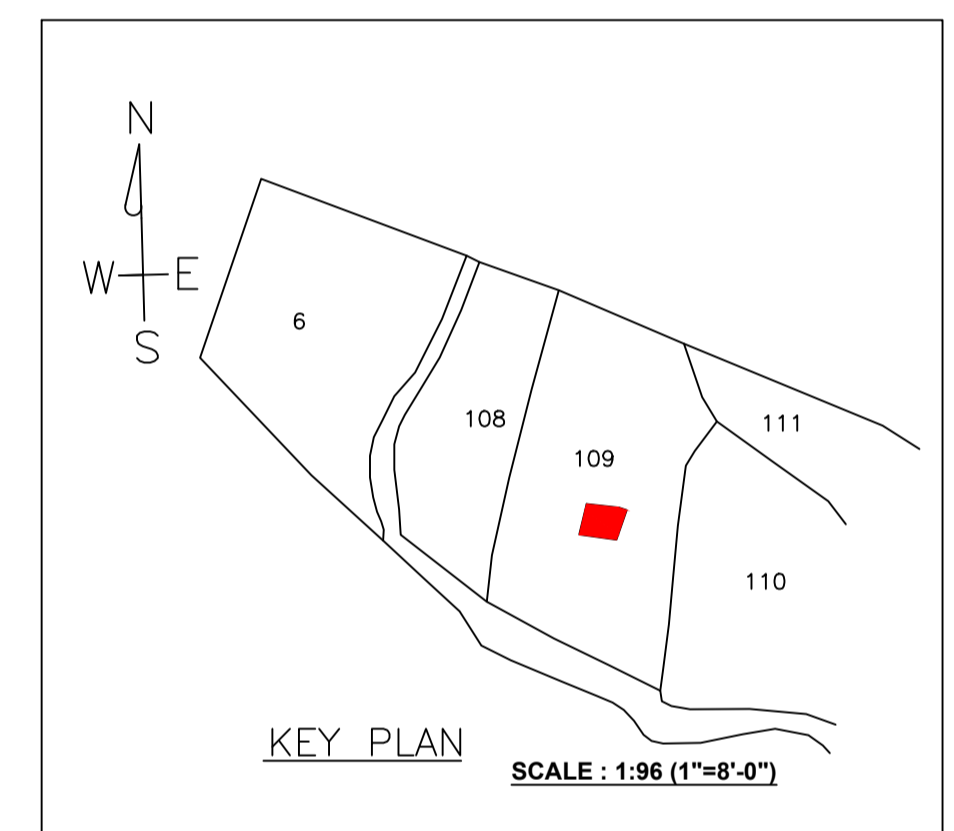

KEY PLAN
SCALE : 1:96 (1"=8'-0")

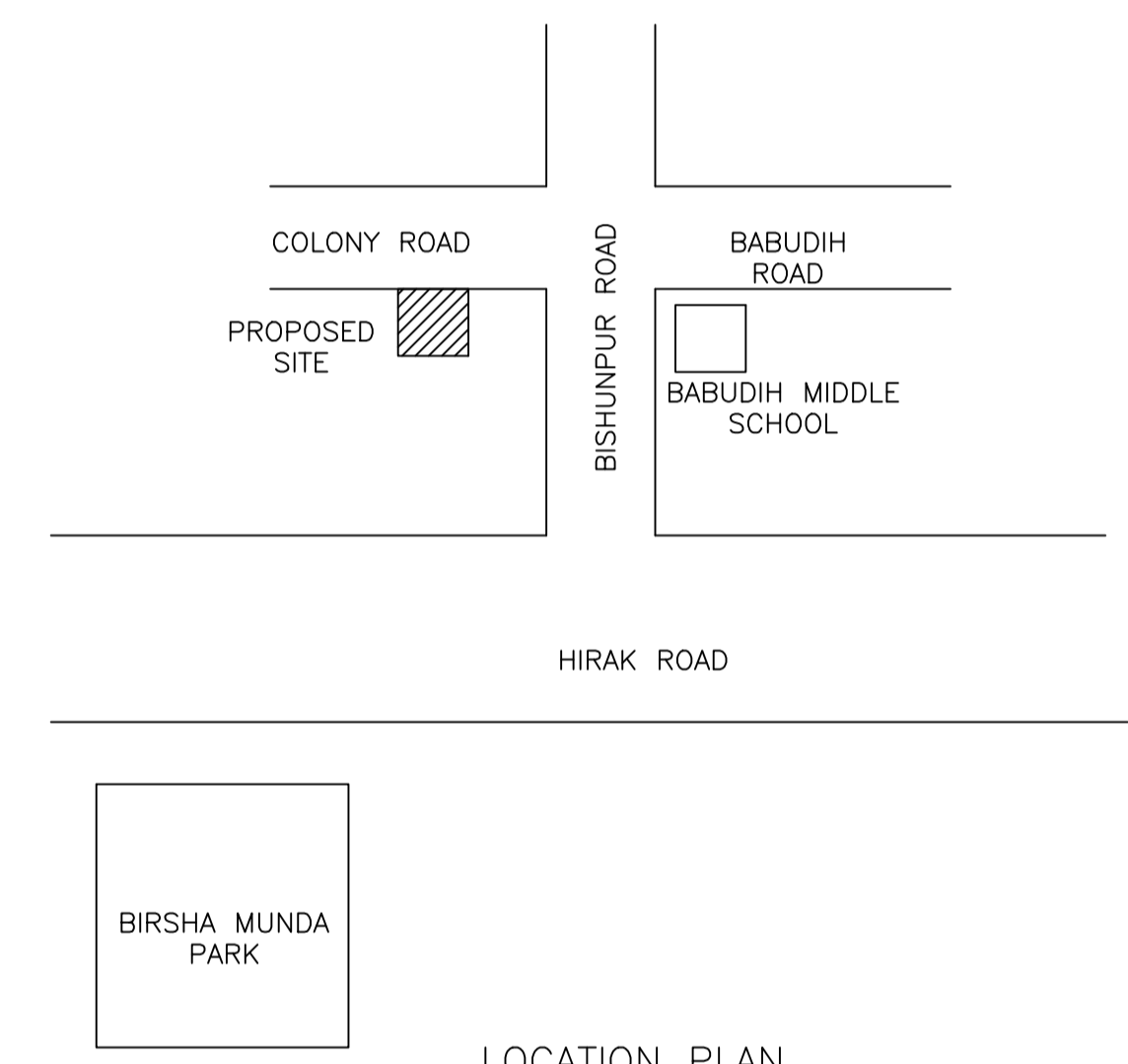

LOCATION PLAN
SCALE : 1:96 (1"=8'-0")

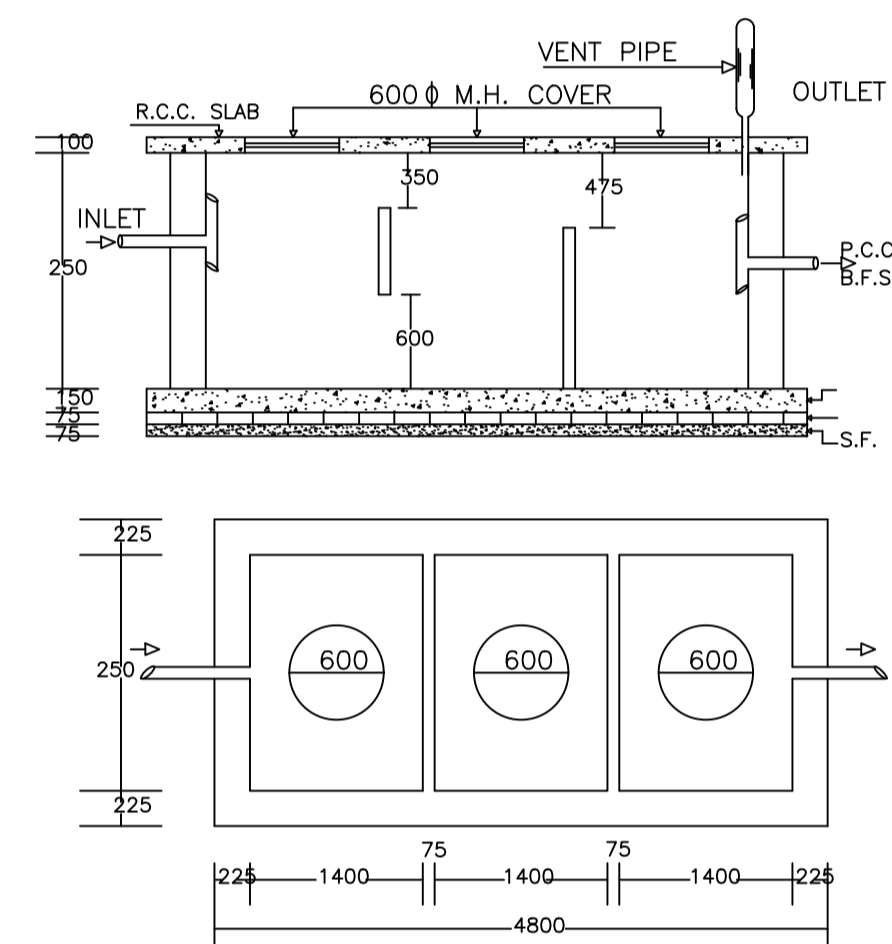

PLAN OF SEPTIC TANK
SCALE : 1:96 (1"=8'-0")

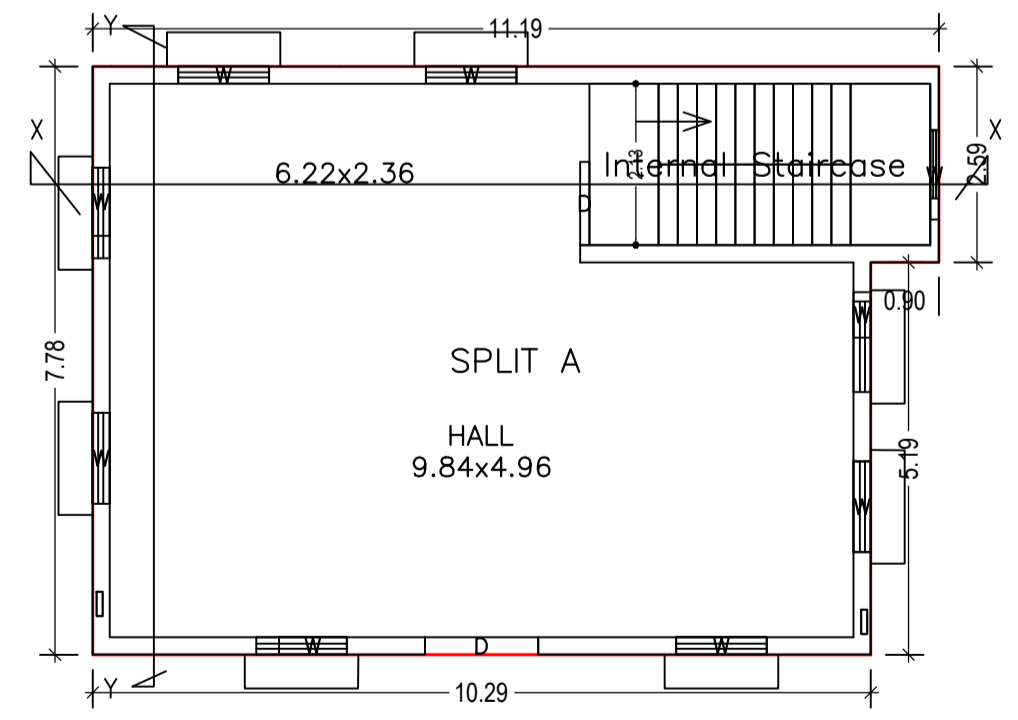

GROUND FLOOR PLAN (Proposed)
SCALE 1:100

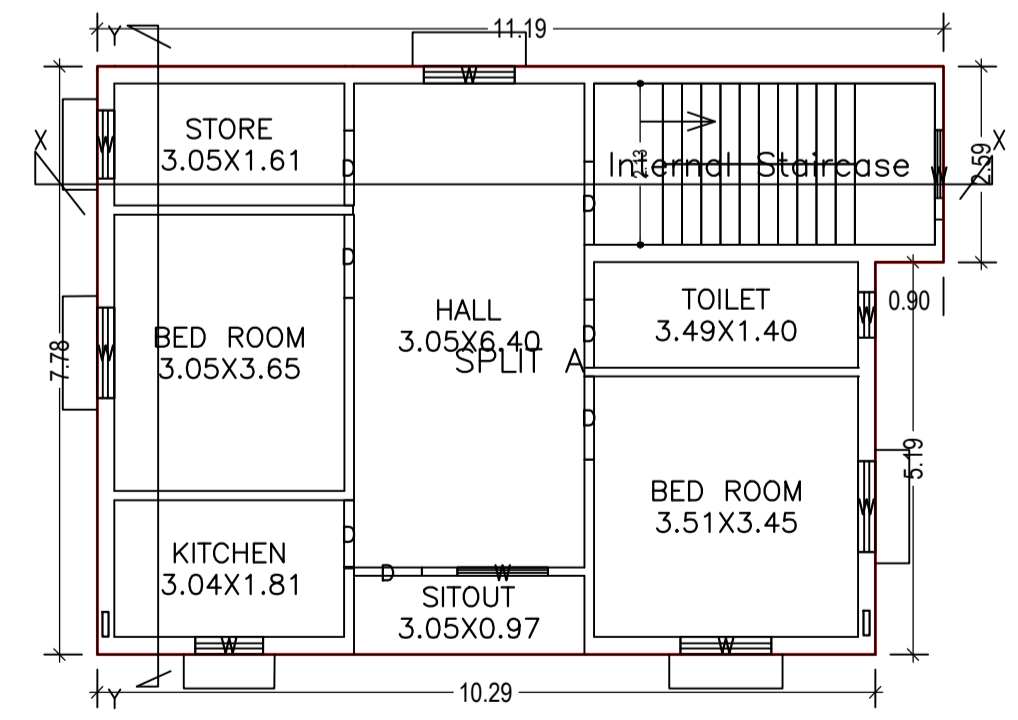

TYPICAL - 1, 2 FLOOR PLAN (Proposed)
SCALE 1:100

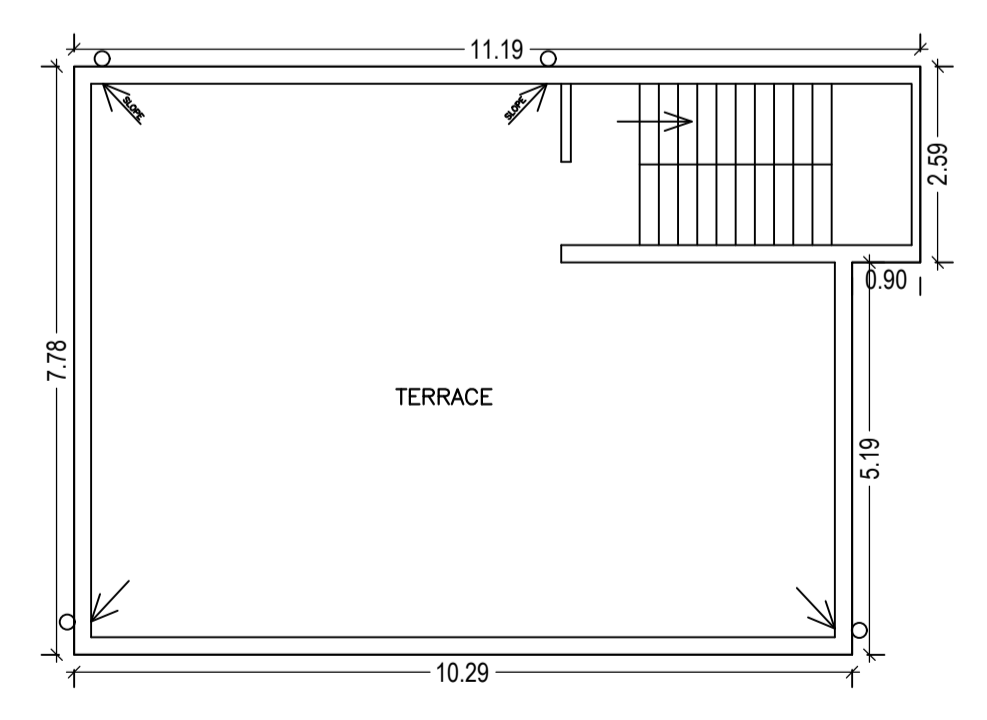

TERRACE FLOOR PLAN
SCALE 1:100

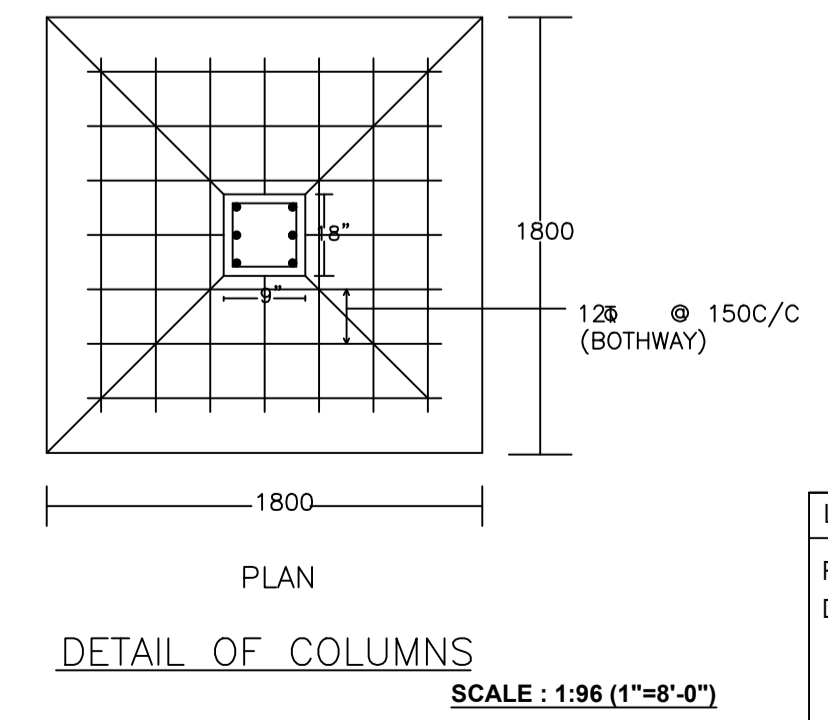
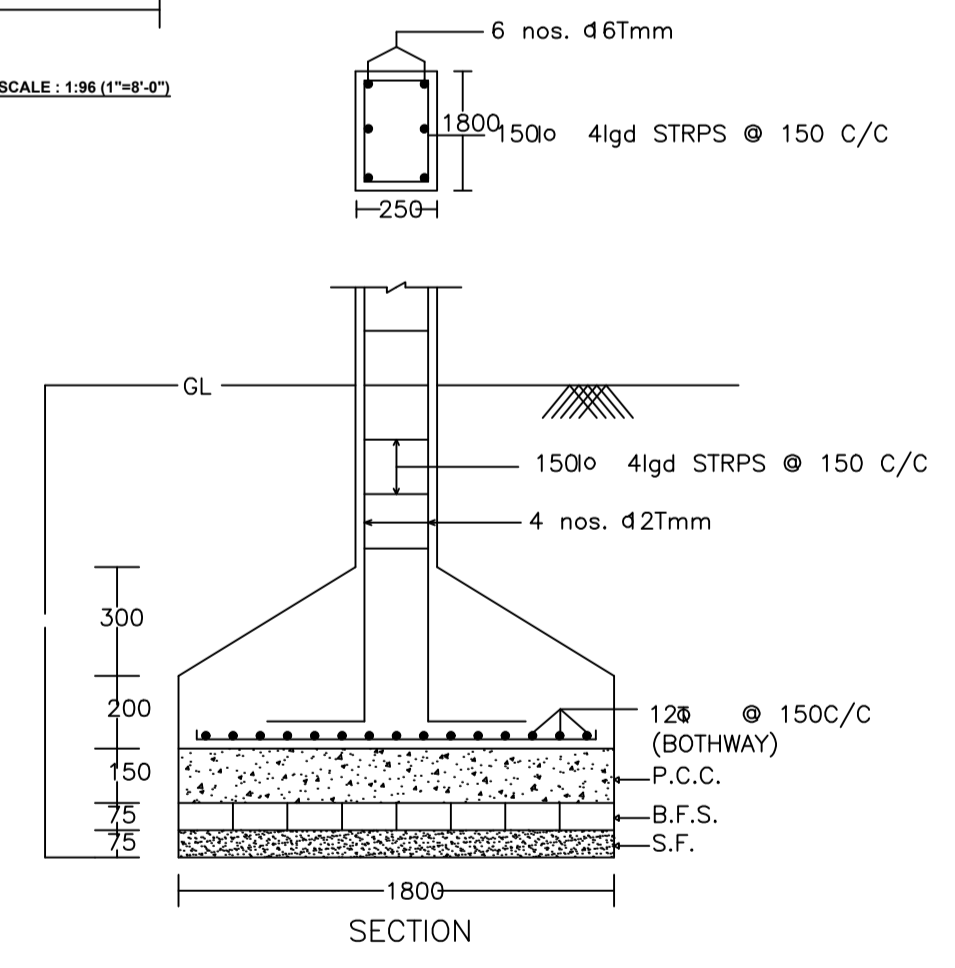

DETAIL OF COLUMNS
SCALE : 1:96 (1"=8'-0")

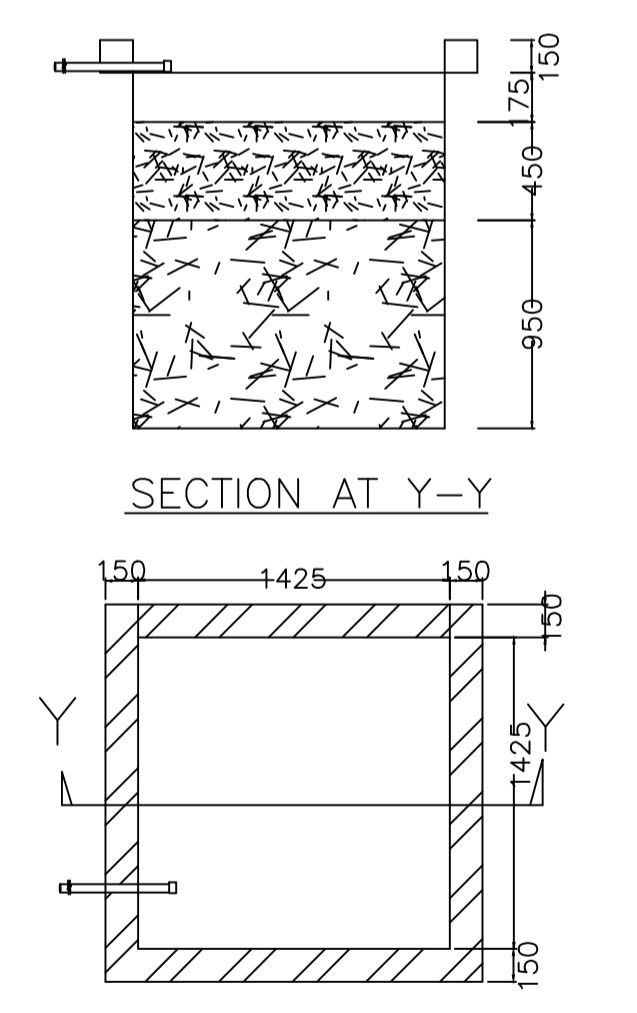

SECTION AT Y-Y
PLAN OF RECHARGE WELL WATER HARVESTING
SCALE : 1:96 (1"=8'-0")

| LTP NAME AND SIGNATURE | STRUCTURAL ENG'S NAME AND SIGNATURE | BUILDER NAME AND SIGNATURE | DIGITAL SIGNATURE |
|--|-------------------------------------|----------------------------|-------------------|
| RAJEEV RANJAN SINGH DMC/ENG/0032/2017 | | | |