

Project Title - SMT. PINKI KUMARI

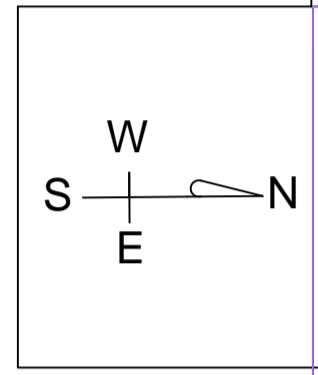
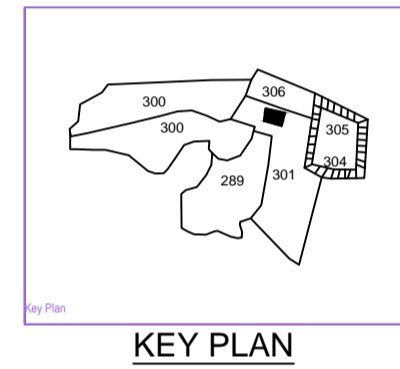
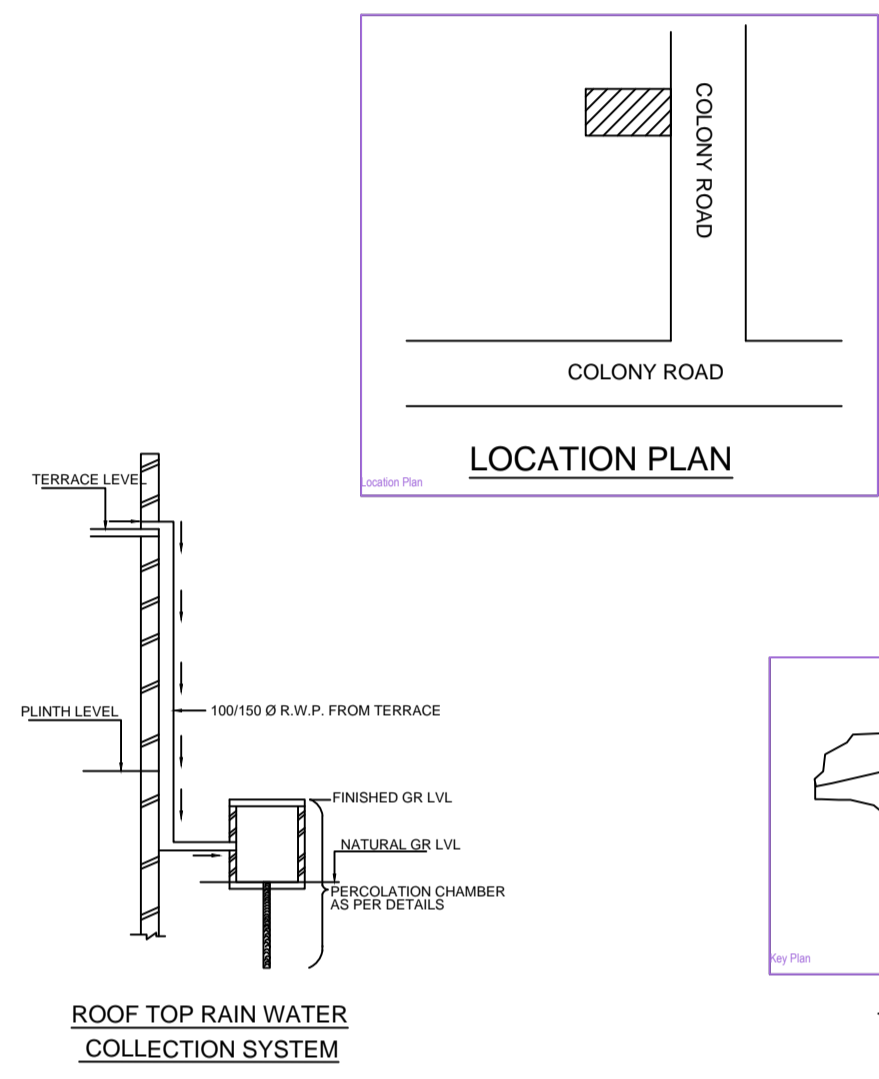
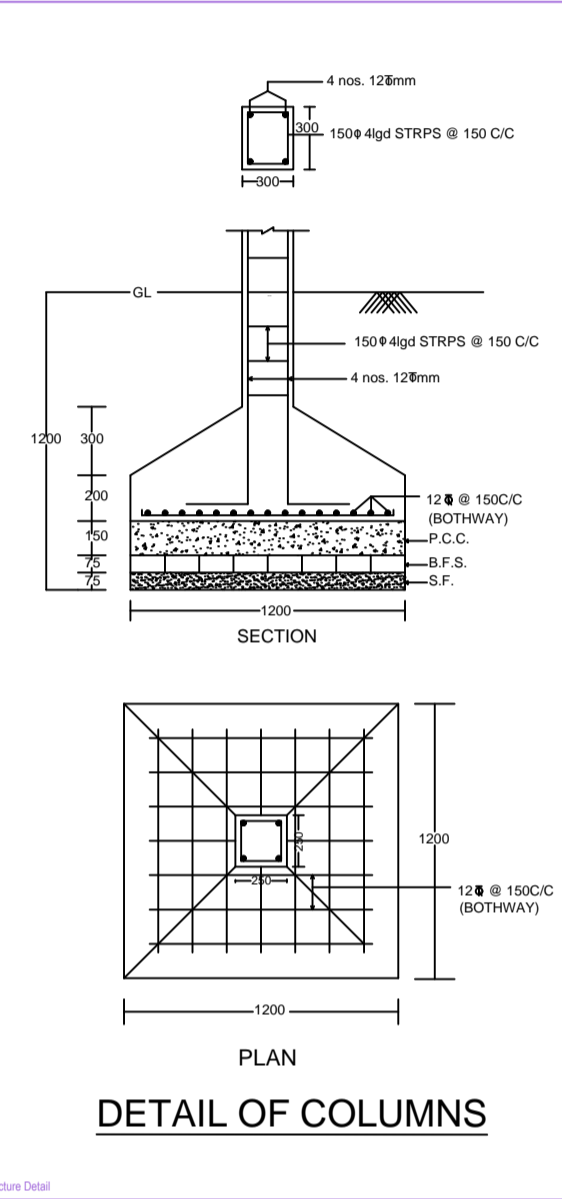
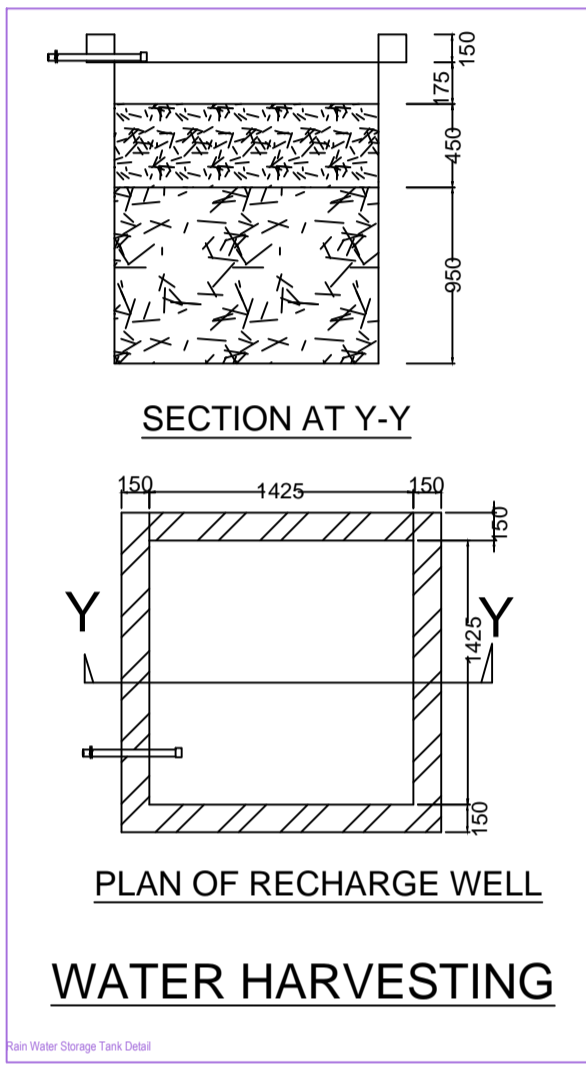
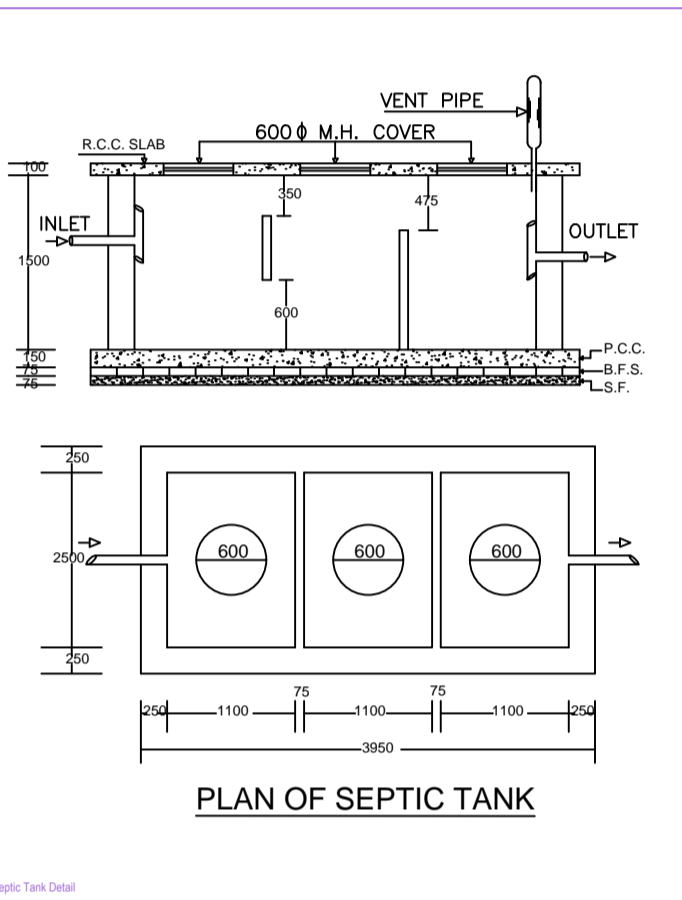
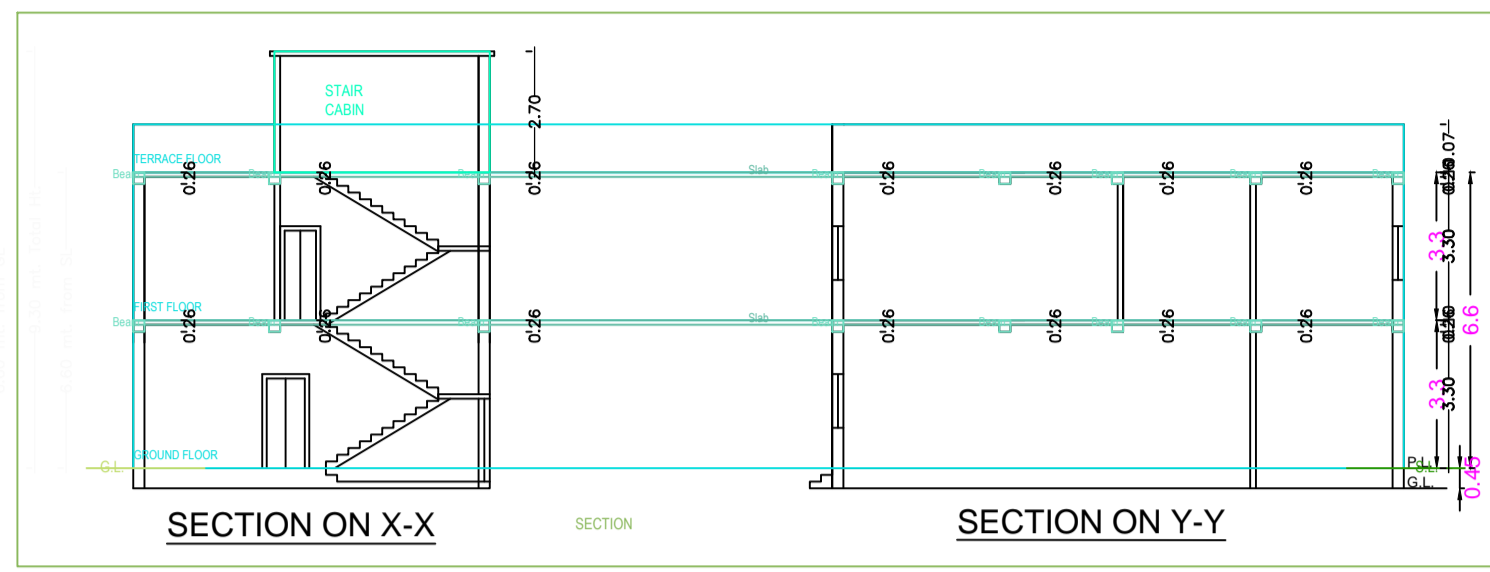
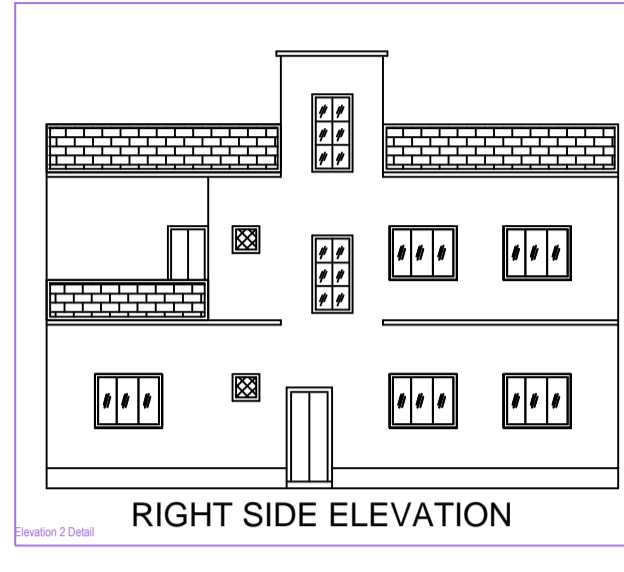
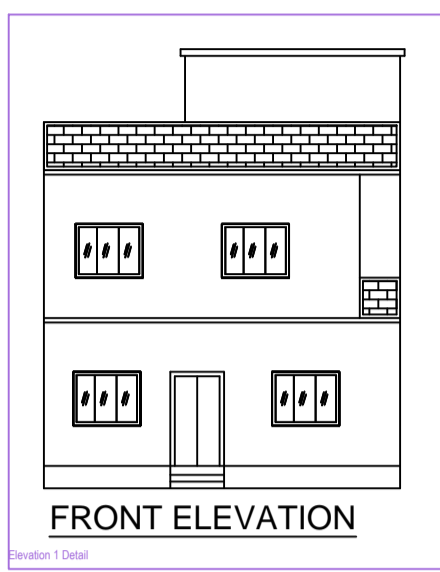

BRIEF SPECIFICATION
 FOUNDATION----- CEMENT CONCRETE (1:1.5:3)
 BRICK WORK IN FOUNDATION & SUPERSTRUCTURE
 FIRST CLASS BRICK WORK IN CEMENT MORTAR (1:6)
 D.P.C.-----25 D.P.C. IN CEMENT CONCRETE (1:2:4)
 FLOOR-----25 I.P.S. OVER 75 P.C.C.
 ROOF-----100 THK. R.C.C. ROOF (1:1.5:3)
 LINTEL-----150 THK. R.C.C. LINTEL (1:1.5:3)
 STAIRS----- RISE-- 150, TREAD-- 250

DETAILS OF AREA

TOTAL AREA (AS PER DEED)	150.50 SQM.
TOTAL AREA (AS PER SITE)	150.19 SQM.
GROUND FLOOR AREA	101.36 SQM.
FIRST FLOOR AREA	101.36 SQM.
TOTAL COVERED AREA	203.72 SQM.
% PLINTH AREA	67.48 %
FAR	1.35

SCHEDULE

D = 1.200X2.100	W1 = 1.500X1.200
D1 = 1.050X2.100	W2 = 1.200X1.200
D2 = 0.900X2.100	V = 0.600X0.600

TITLE OF DRAWING
 PLAN OF PROPOSED RESIDENTIAL BUILDING OF SMT. PINKI KUMARI W/O DHARMENDRA KUMAR OF BHISTIPARA, HIRAPUR, DHANBAD, UNDER MOUZA BARAMURI, NO.- 03, KHATA NO.- 35, PLOT NO.- 301 IN THE DISTT. OF DHANBAD (JHARKHAND).

SIGNATURE OF OWNER

SIGNATURE OF ENGINEER

SCALE ALL DIMENSION ARE IN METRE

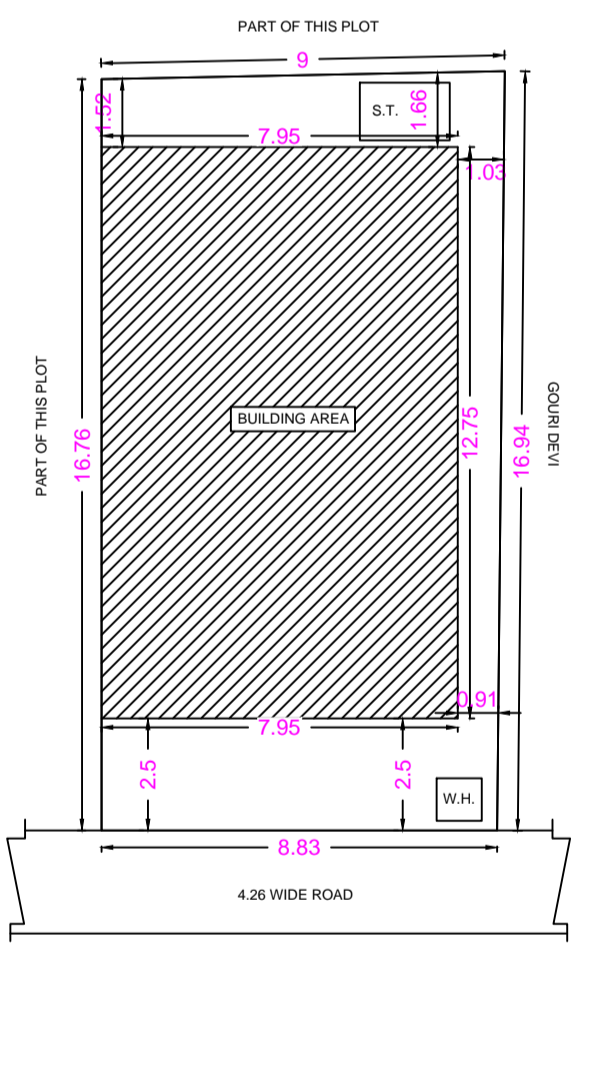
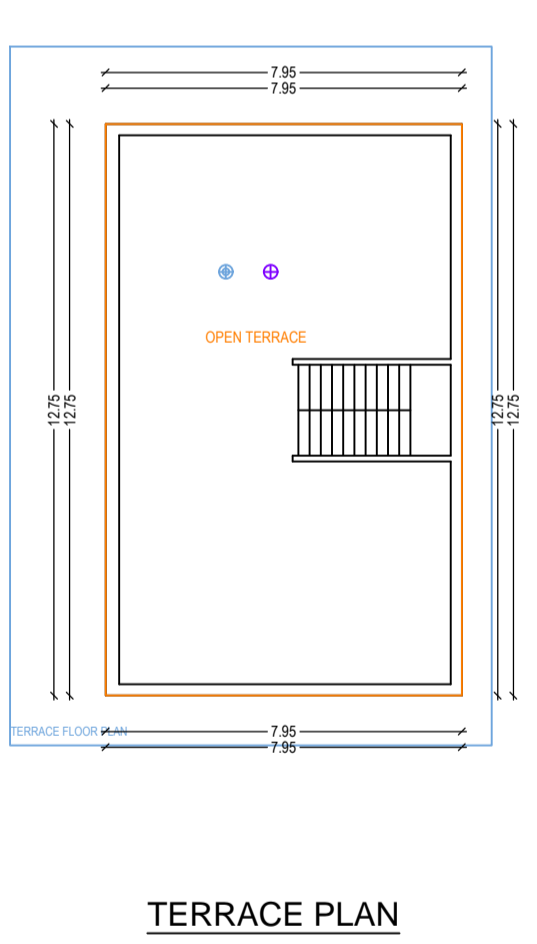
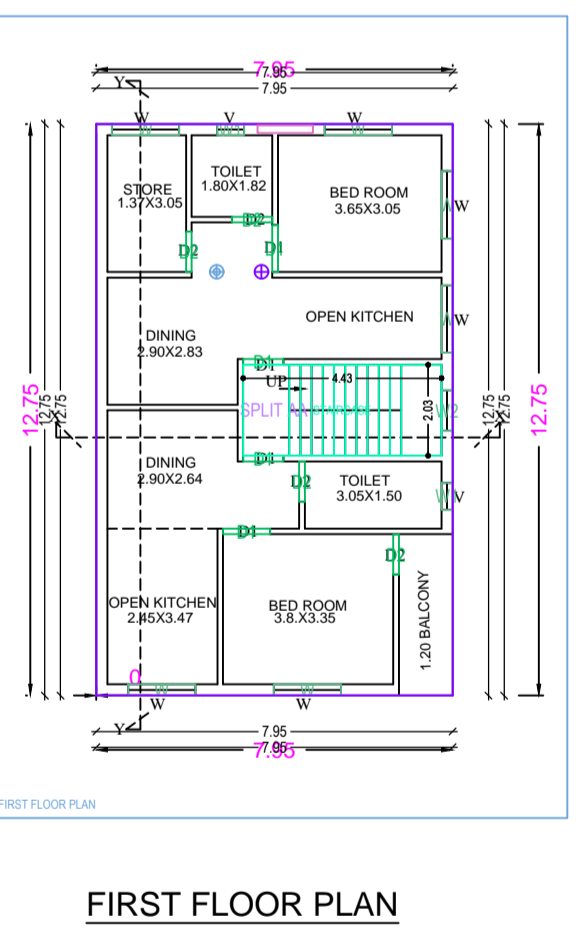
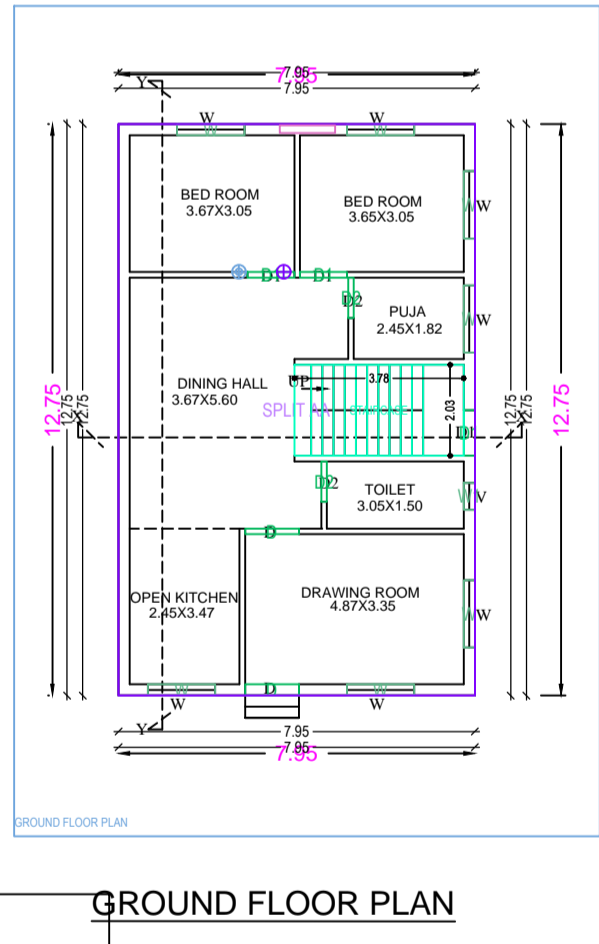
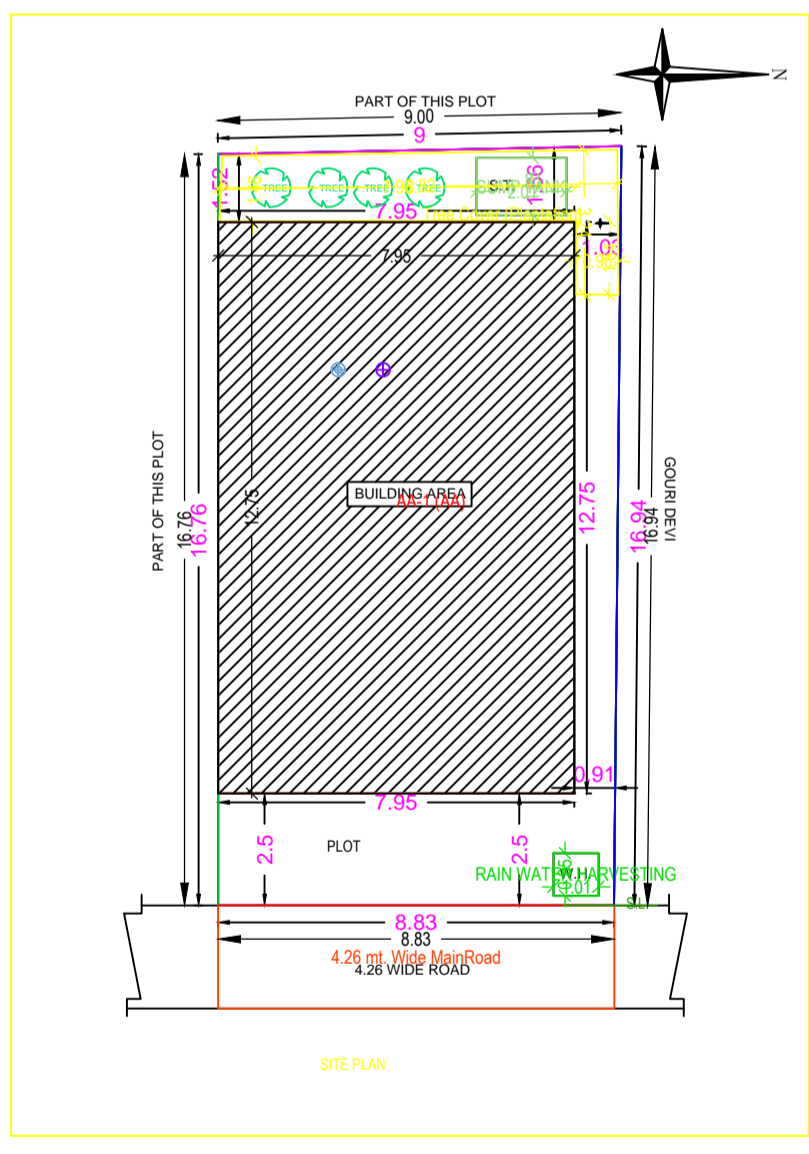

Building -AA (AA)

Floor Name	Total Built Up Area (Sq.mt)	Proposed FAR Area (Sq.mt)	Total FAR Area (Sq.mt)	Terrace (No)
Ground Floor	101.36	101.36	101.36	01
First Floor	101.36	101.36	101.36	01
Terrace Floor	0.00	0.00	0.00	00
Total	202.72	202.72	202.72	01
Total Number of Same Buildings	1	-	-	-
Total	202.72	202.72	202.72	01

SCHEDULE OF JOINERY:

BUILDING NAME	NAME	LENGTH	HEIGHT	NO
AA (AA)	W1	0.60	2.10	06
AA (AA)	D1	0.90	2.10	09
AA (AA)	D2	1.01	2.10	09
AA (AA)	D3	1.05	2.10	04
AA (AA)	D4	1.20	2.10	02
Total	-	-	-	17

SCHEDULE OF JOINERY:

BUILDING NAME	NAME	LENGTH	HEIGHT	NO
AA (AA)	W1	0.60	1.20	03
AA (AA)	W2	0.90	1.20	01
AA (AA)	W	1.00	1.20	13
Total	-	-	-	17

UnBUSA Table for Building -AA (AA)

FLOOR	Name	UNBUSA Type	UNBUSA Area	Carpet Area	No. of Rooms	No. of Terrace
GROUND FLOOR PLAN	SPLIT AA	FLAT	202.72	202.30	4	1
Total	-	-	202.72	202.30	14	1

AREA STATEMENT: DHANBAD MUNICIPAL CORPORATION
 VERSION NO. 1.034
 VERSION DATE: 01/01/2019

PROJECT DETAIL:	Plot No.:	Plot Use:	Residential
Region:	JHARKHAND URBAN LOCAL BODIES	Plot Subtype:	Single Dwelling / Non Apartment
Location:	Distt: Dhanbad	Local Use Zone:	Residential
Project Type:	General Proposal	Abutting Road Width:	
Nature of Development:	House	Reference Survey No/Survey No.:	
Location:	Distt Area	Thana No.:	
Plot Location:	Yes	Ward No.:	
Village/Muza Name:		Khata No.:	
Ward No.:		East:	
Road/Street:		East:	
		West:	

COLOR INDEX

Color	Description
Black	Plot Boundary
Red	Abutting Road
Green	Proposed Work Coverage Area
Blue	Existing (To be retained)
Yellow	Existing (To be demolished)

MARGIN DETAIL:

Building / W/O	Road Name	Front Margin	Rear Margin	Side Margin	Sold Margin
AA (AA)	4.26 WIDE ROAD	2.50	1.51	0.90	0.00

DETAILS OF AREA

Building	No. of Same Bldg	Total Built Up Area (Sq.mt)	Proposed FAR Area (Sq.mt)	Total FAR Area (Sq.mt)
AA (AA)	1	202.72	202.72	202.72
Grand Total	1	202.72	202.72	202.72

SCHEDULE

D = 1.200X2.100	W1 = 1.500X1.200
D1 = 1.050X2.100	W2 = 1.200X1.200
D2 = 0.900X2.100	V = 0.600X0.600

TITLE OF DRAWING
 PLAN OF PROPOSED RESIDENTIAL BUILDING OF SMT. PINKI KUMARI W/O DHARMENDRA KUMAR OF BHISTIPARA, HIRAPUR, DHANBAD, UNDER MOUZA BARAMURI, NO.- 03, KHATA NO.- 35, PLOT NO.- 301 IN THE DISTT. OF DHANBAD (JHARKHAND).

SIGNATURE OF OWNER

SIGNATURE OF ENGINEER

SCALE ALL DIMENSION ARE IN METRE