

Building USE/SUBUSE Details

Building Name	Building Use	Building SubUse	Building Structure
A (A)	Residential	Residential Bldg/Apartment	Non-Highrise

SCHEDULE OF DOOR:

BUILDING NAME	NAME	LENGTH	HEIGHT	NOS
A (A)	d	0.90	2.10	13

SCHEDULE OF WINDOW/VENTILATION:

BUILDING NAME	NAME	LENGTH	HEIGHT	NOS
A (A)	w	1.00	1.20	04
A (A)	w	1.02	1.20	02
A (A)	w	1.80	1.20	09
A (A)	w	3.16	1.20	02

Building :A (A)

Floor Name	Total Built Up Area (Sq.mt.)	Deductions (Area in Sq.mt.)	Proposed FAR Area (Sq.mt.)	Total FAR Area (Sq.mt.)	Total Consumed Additional FAR Area (Sq.mt.)	Tnmt (No.)
Ground Floor	110.40	16.42	93.98	93.98	93.98	01
First Floor	110.46	0.00	110.46	110.46	110.46	00
Terrace Floor	0.00	0.00	0.00	0.00	0.00	00
Total:	220.86	16.42	204.44	204.44	204.44	01
Total Number of Same Buildings	1	-	-	-	-	-
Total:	220.86	16.42	204.44	204.44	204.44	01

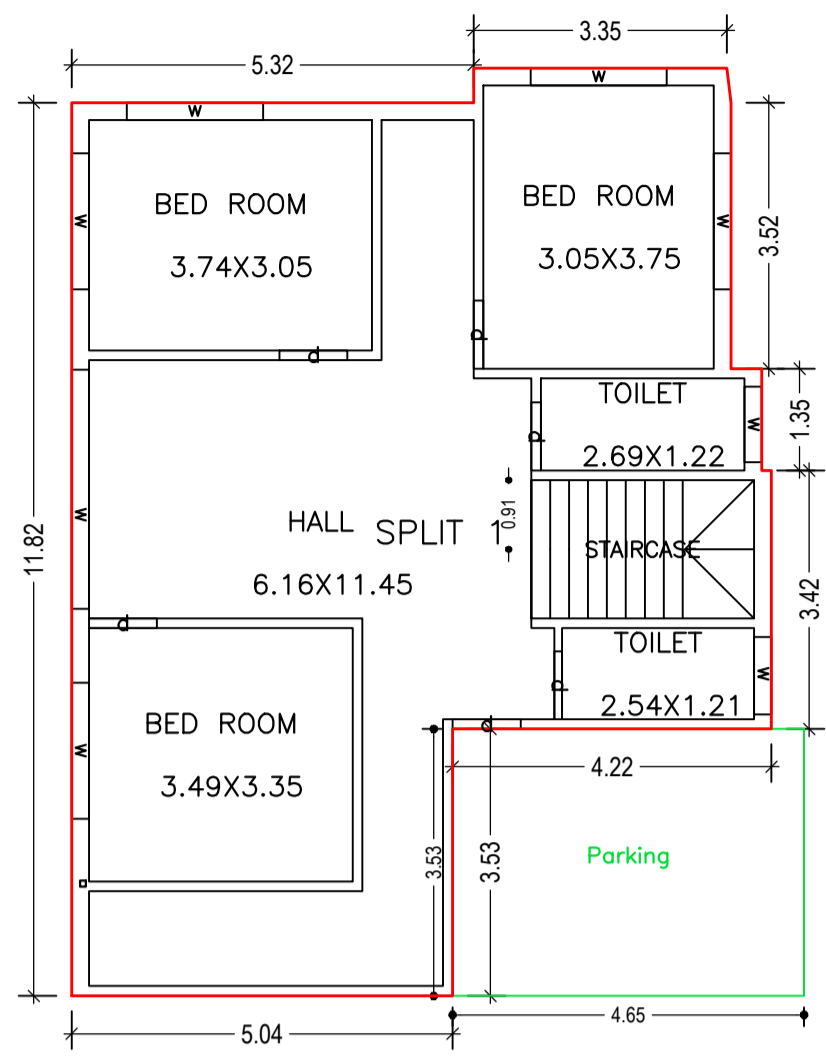

GROUND FLOOR PLAN (Proposed) (SCALE 1:100)

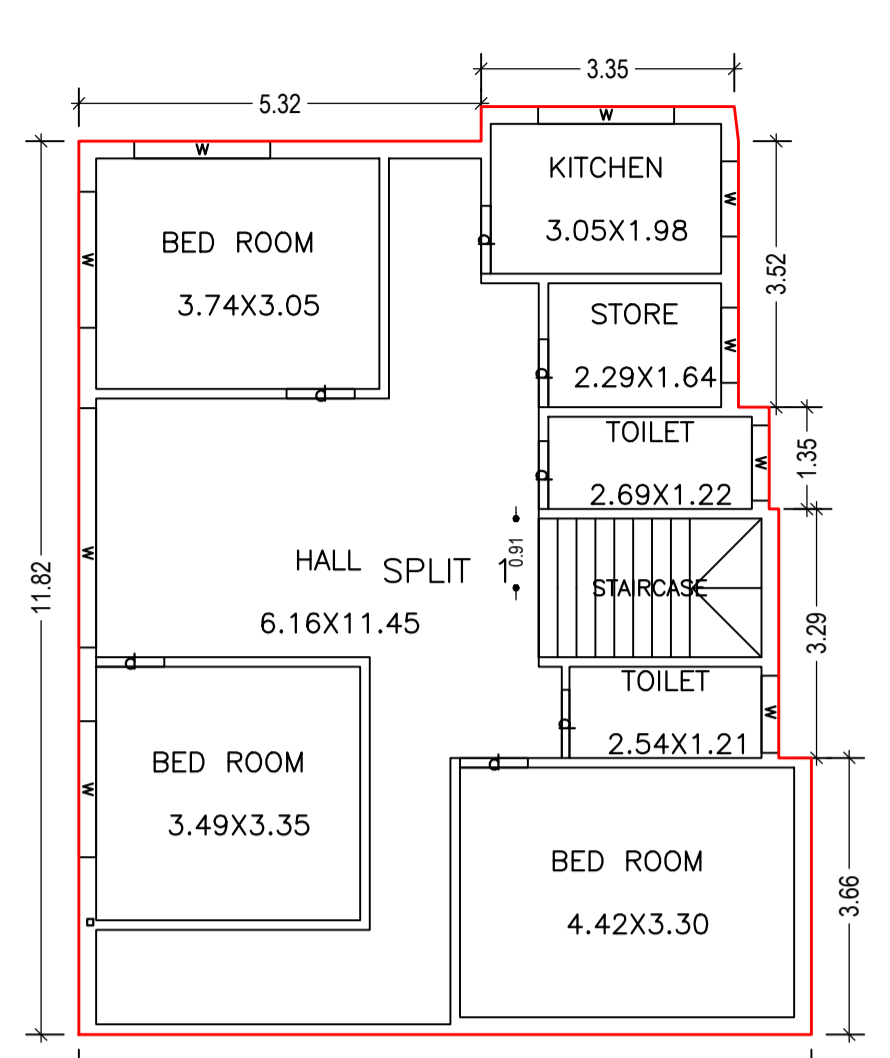

FIRST FLOOR PLAN (Proposed) (SCALE 1:100)

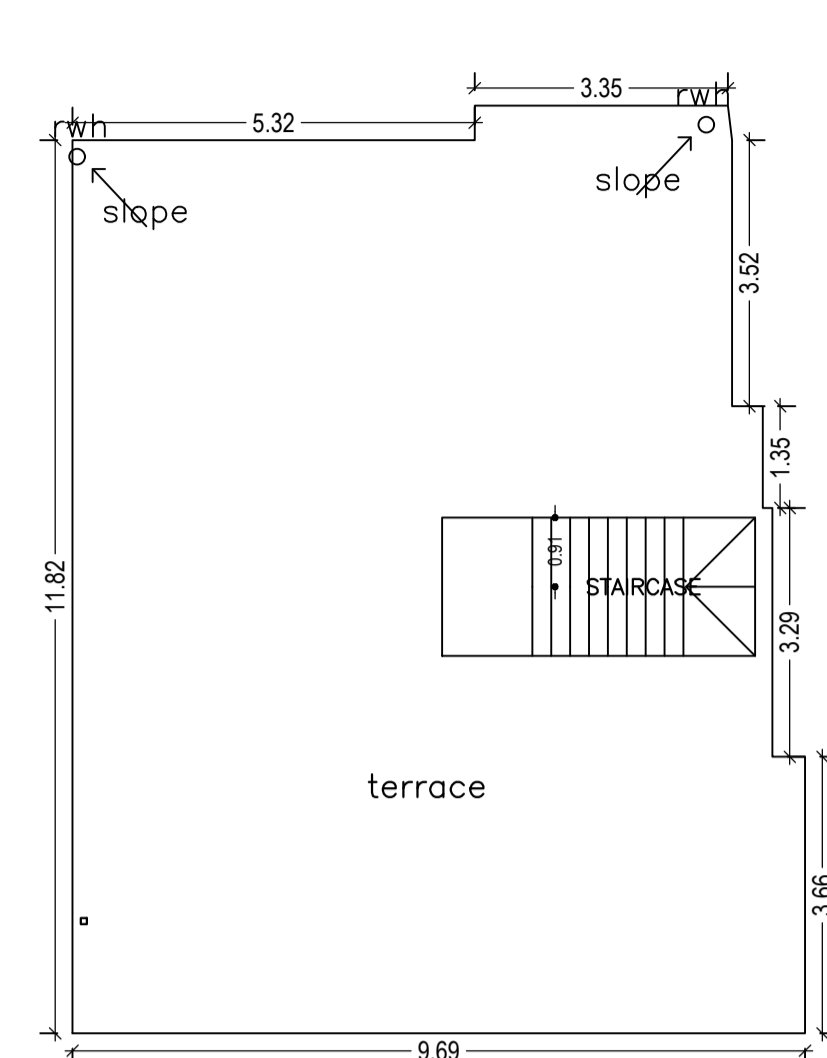

TERRACE FLOOR PLAN (SCALE 1:100)

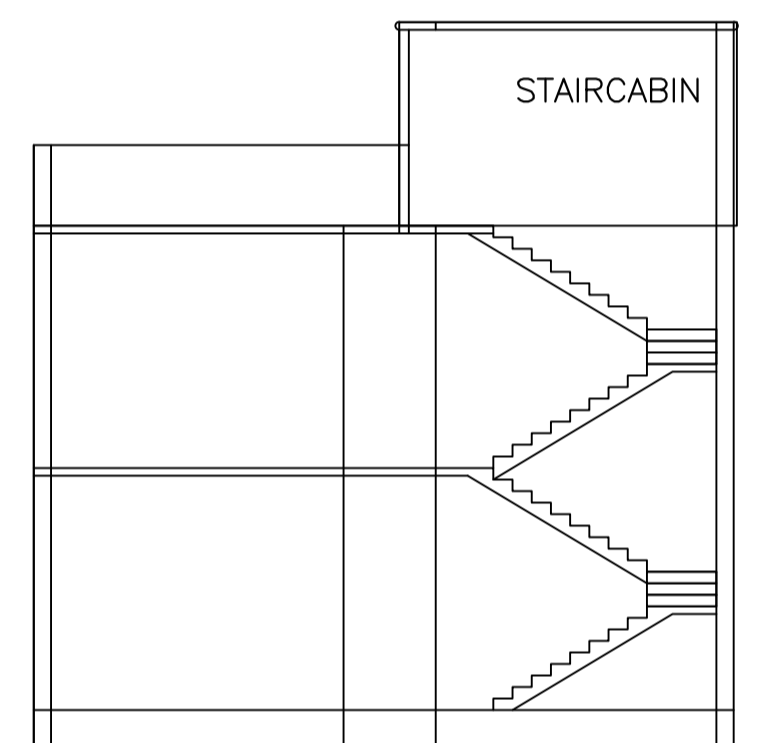

SECTION ON X-X

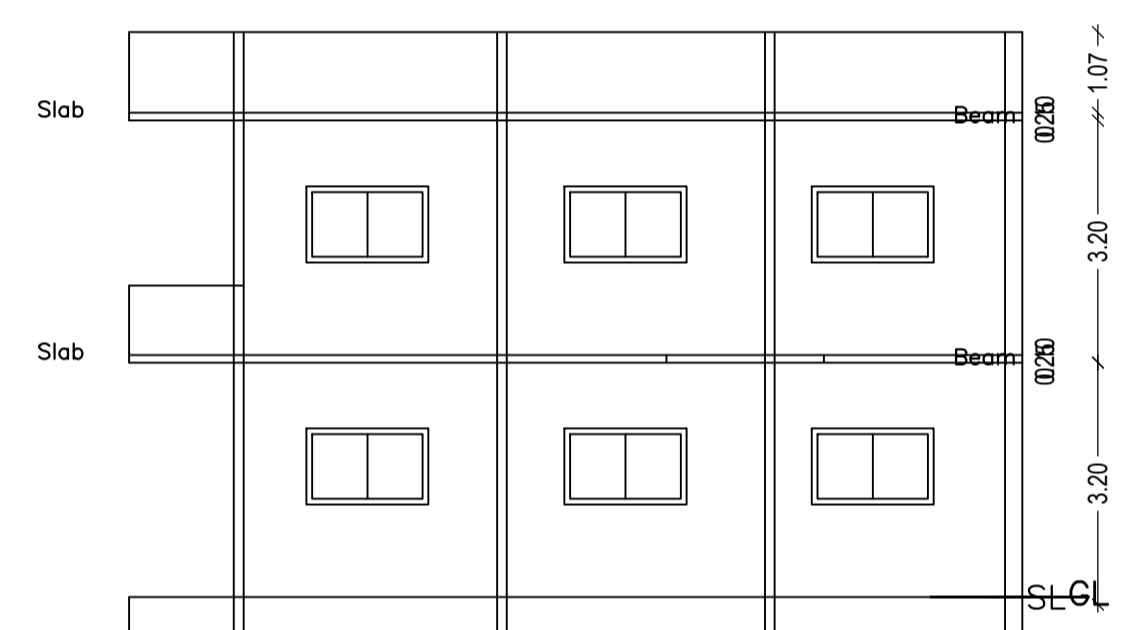

SECTION ON Y-Y

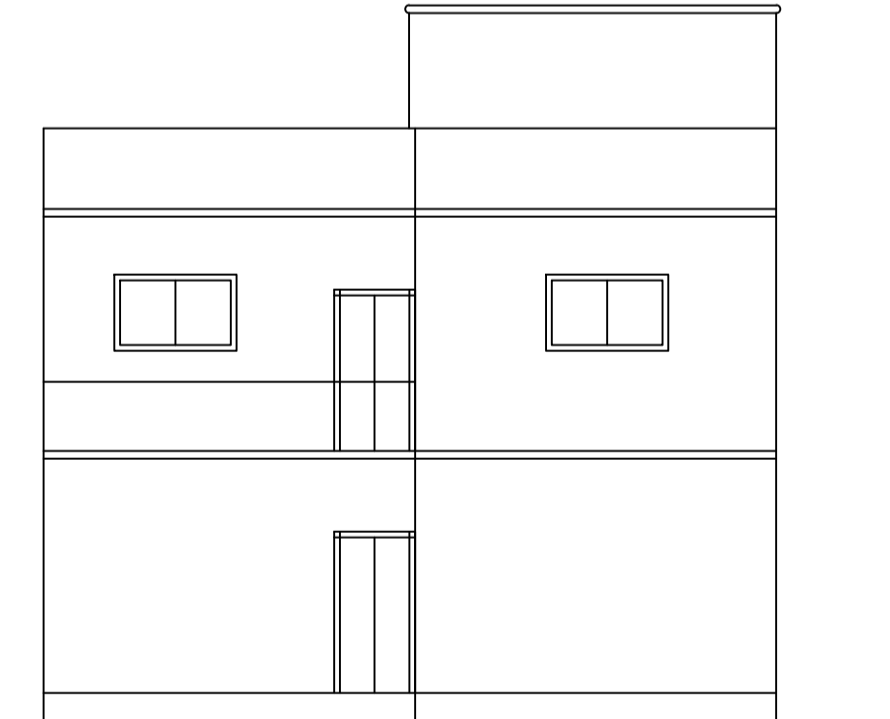

FRONT ELEVATION

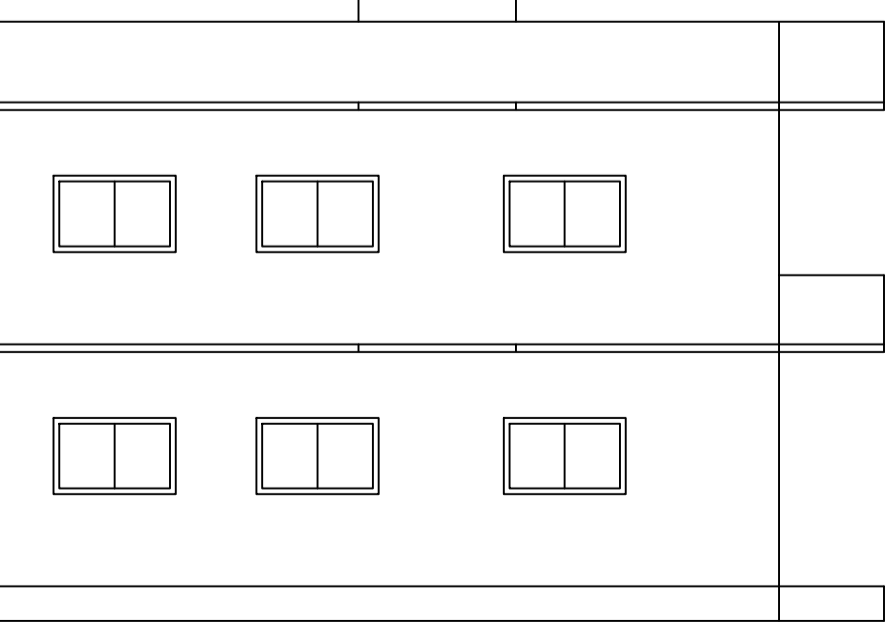

LEFT SIDE ELEVATION

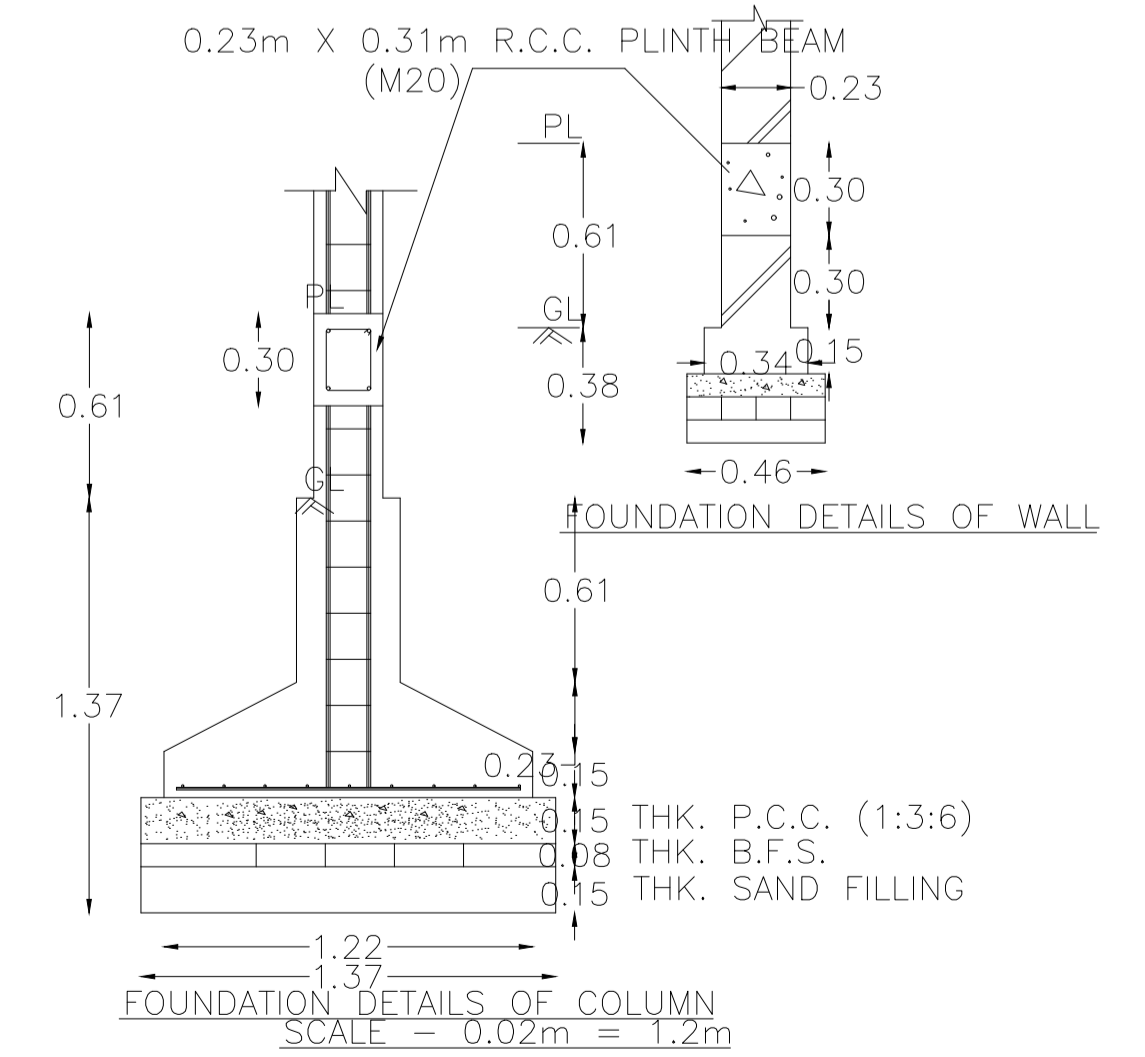

FOUNDATION DETAILS OF COLUMN SCALE = 0.02m = 1.2m

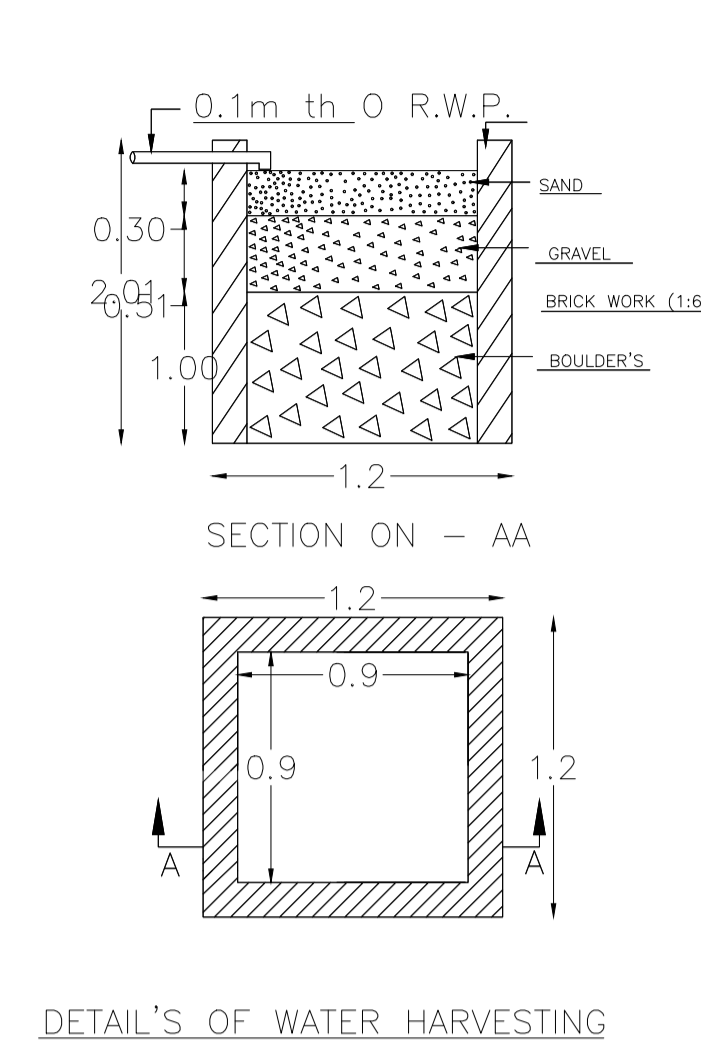

DETAILS OF WATER HARVESTING

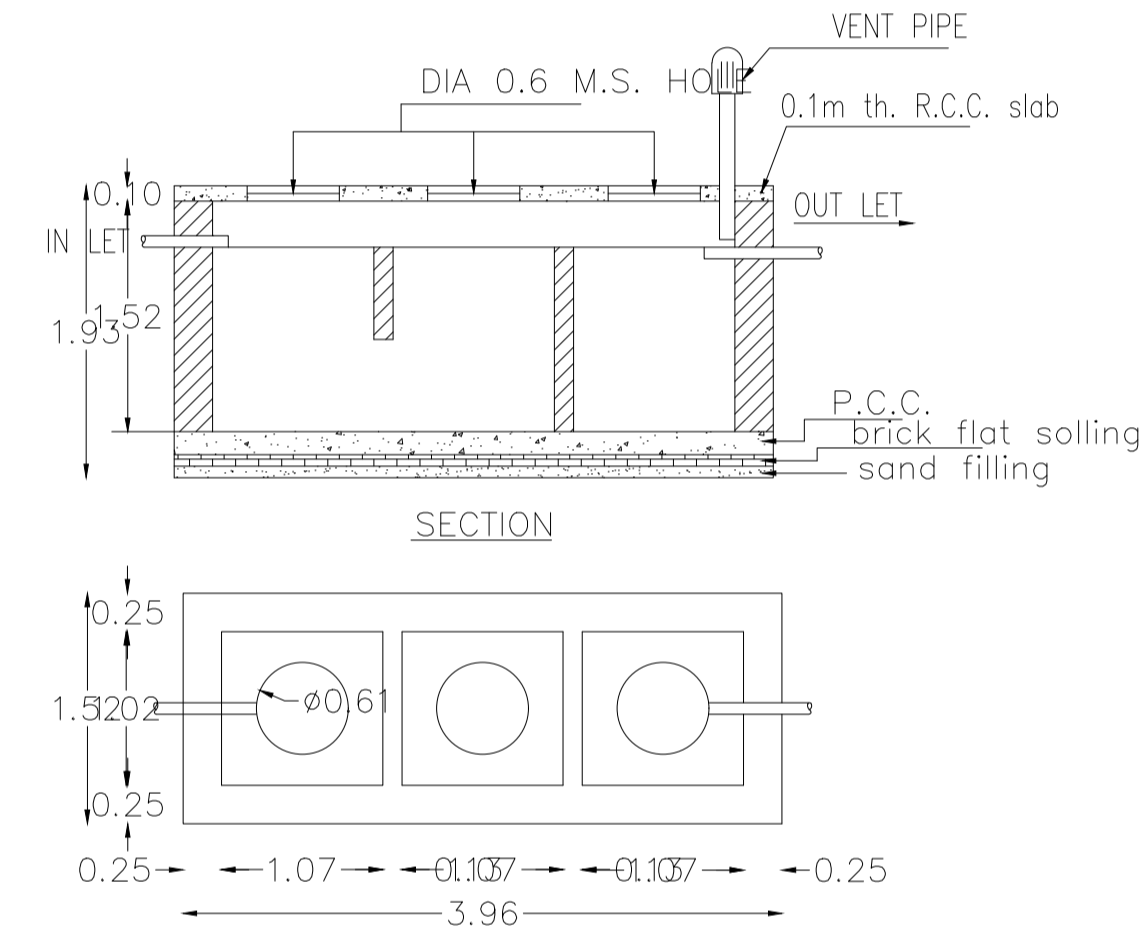

DETAILS OF SEPTIC TANK

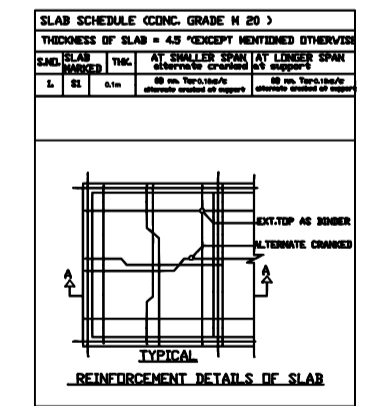

TYPICAL REINFORCEMENT DETAILS OF SLAB

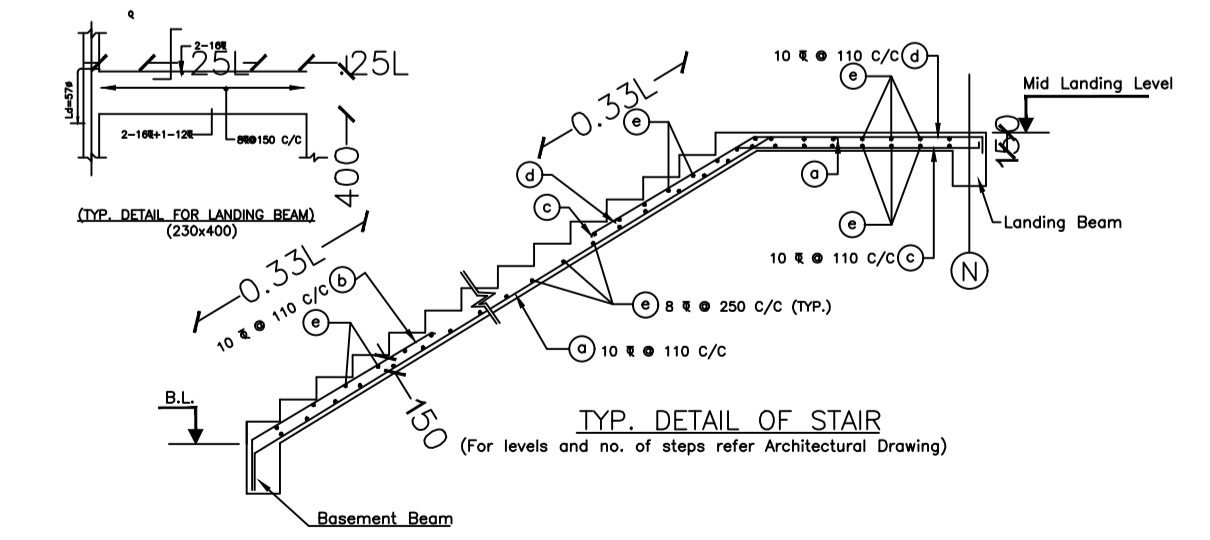

TYP. DETAIL OF STAIR (For levels and no. of steps refer Architectural Drawing)

Proposal Basic Information

Proposal File No.	DMC/BP/0160/W20/2020
Owner Name	SAROJ DEVI
Khata No	OLD - 35, NEW - 99
Plot No	OLD - 301, NEW - 624
Village Name	Baramuri
Use	Residential
SubUse	Bungalow/ Dwelling / Non Apartment

COLOR INDEX

PLOT BOUNDARY	Black
ABUTTING ROAD	Red
PROPOSED CONSTRUCTION	Green
COMMON PLOT	Yellow
ROAD WIDENING AREA	Blue
EXISTING (To be retained)	Orange
EXISTING (To be demolished)	Purple

AREA STATEMENT

AREA DETAILS:	VERSION NO.:	SQ.MT.
AREA OF PLOT (Minimum)	1.0.48	184.58
NET AREA OF PLOT (Gross Plot Area - Deduction from Gross Plot Area)	22/06/2020	184.58
Deduction for Balance Plot Area (from Gross Plot Area)		18.96
Common Plot		18.96
BALANCE AREA OF PLOT (Net Plot Area - Recreational/Amenity space)	(A-Deductions)	165.62
PLOT AREA FOR COVERAGE (Net Plot Area + Road/Widening Area)	(A-Deductions)	184.58
Plot Area for FAR (Net Plot Area + Road/Widening Area)	(A-Deductions)	184.58
COVERAGE CHECK		
Permissible Coverage area (70.00 %)		129.21
Proposed Coverage Area (59.81 %)		110.40
Total Prop. Coverage Area (59.81 %)		110.40
Balance coverage area (10.19 %)		18.81
FAR CHECK		
Perm. FAR Area (1.50)		276.87
Total Perm. FAR area		276.87
Residential FAR		204.44
Proposed FAR Area		204.44
Total Proposed FAR Area		204.44
Consumed FAR (Factor)		1.11
Balance FAR Area		72.43
BUILT UP AREA CHECK		
Total Proposed BuiltUp Area		220.86
ARCHITECT (Regd)	HARSH NANDAN KUMAR	
ENGINEER (Regd)		
SUPERVISOR (Regd)		
OWNER (Regd)	SAROJ DEVI	
DEVELOPMENT AUTHORITY	LOCAL BODY	

Buildingwise Floor FAR Details

Floor Name	Building Name		Total	
	Proposed Built Up Area (Sq.mt.)	Proposed FAR Area (Sq.mt.)	Total Proposed Built Up Area (Sq.mt.)	Total FAR Area (Sq.mt.)
Ground Floor	110.40	93.98	110.40	93.98
First Floor	110.46	110.46	110.46	110.46
Terrace Floor	0.00	0.00	0.00	0.00
Total:	220.86	204.44	220.86	204.44

FAR & Tenement Details (Table 4c-1)

Building	No. of Same Bldg	Total Built Up Area (Sq.mt.)	Deductions (Area in Sq.mt.)	Proposed FAR Area (Sq.mt.)	Total FAR Area (Sq.mt.)	Total Consumed Additional FAR Area (Sq.mt.)	Tnmt (No.)
A (A)	1	220.86	16.42	204.44	204.44	204.44	01
Grand Total:	1	220.86	16.42	204.44	204.44	204.44	01

UnitBUA Table for Building :A (A)

FLOOR	Name	UnitBUA Type	UnitBUA Area	Carpet Area	No. of Rooms	No. of Tenement
GROUND FLOOR PLAN	SPLIT 1	FLAT	204.44	204.42	6	1
FIRST FLOOR PLAN	SPLIT 1	FLAT	0.00	0.00	8	0
Total:	-	-	204.44	204.42	14	1

LTP NAME AND SIGNATURE	STRUCTURAL ENG'S NAME AND SIGNATURE	BUILDER NAME AND SIGNATURE	DIGITAL SIGNATURE
HARSH NANDAN KUMAR DMC/ENG/0001/2018			