

SITE PLAN

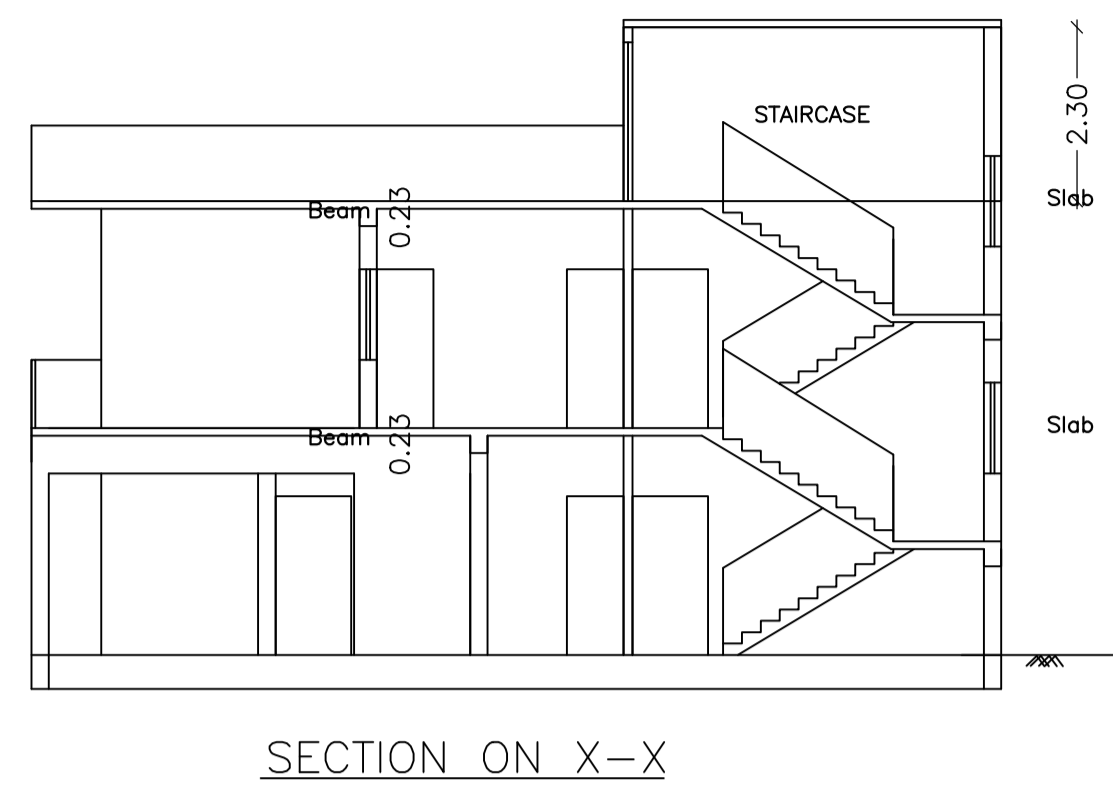

SECTION ON X-X

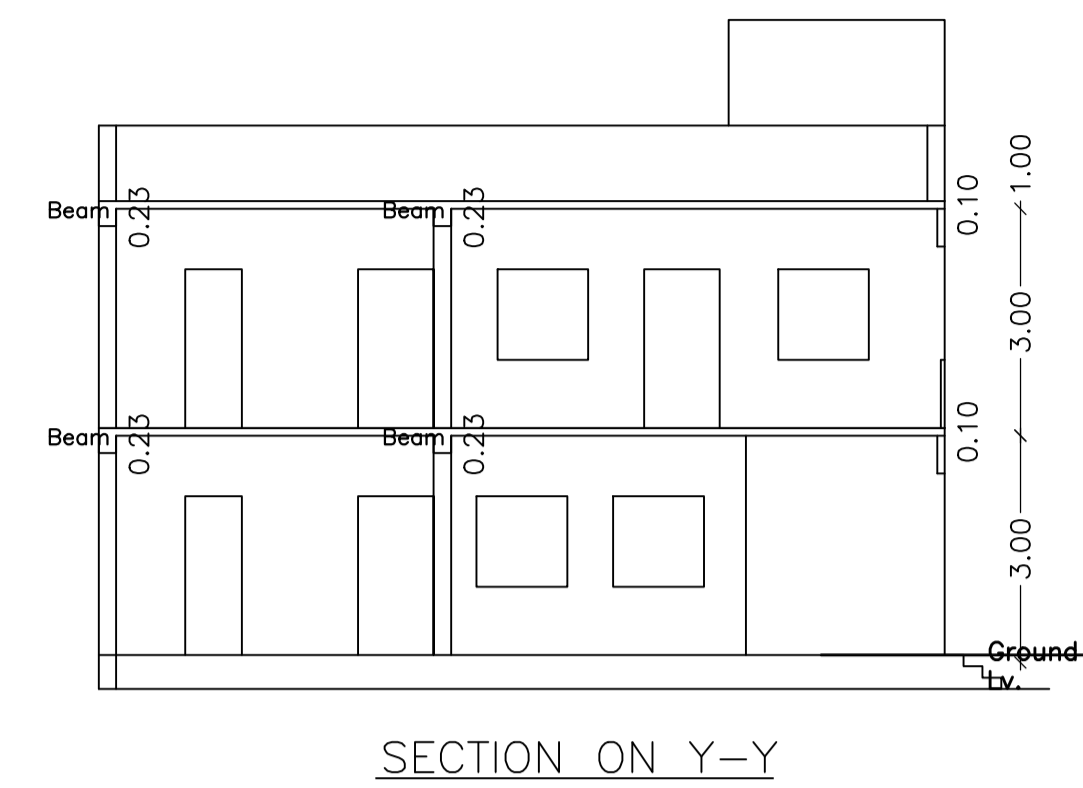

SECTION ON Y-Y

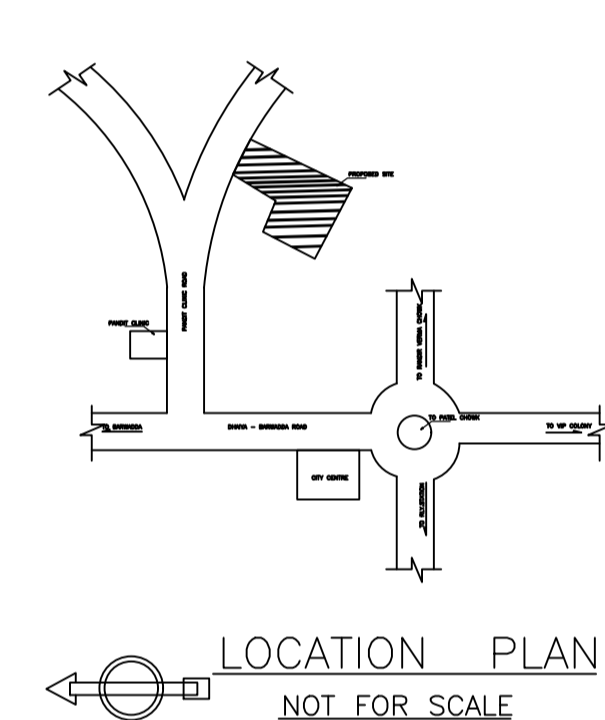

LOCATION PLAN NOT FOR SCALE

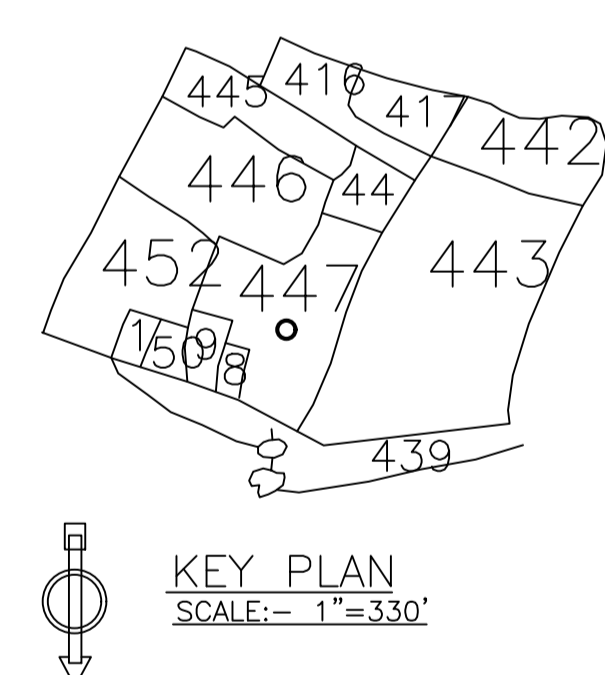

KEY PLAN SCALE:- 1"=330'

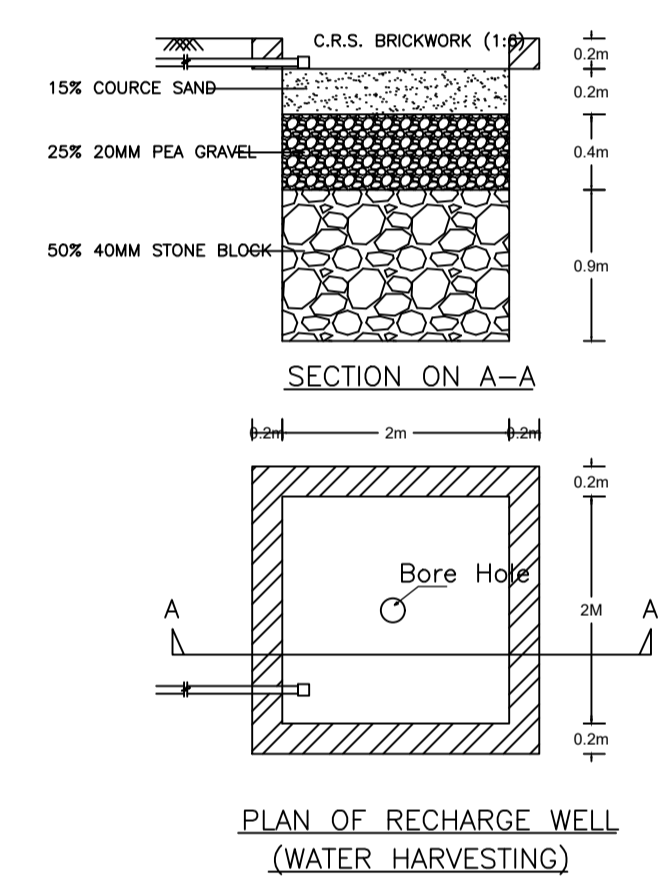

PLAN OF RECHARGE WELL (WATER HARVESTING)

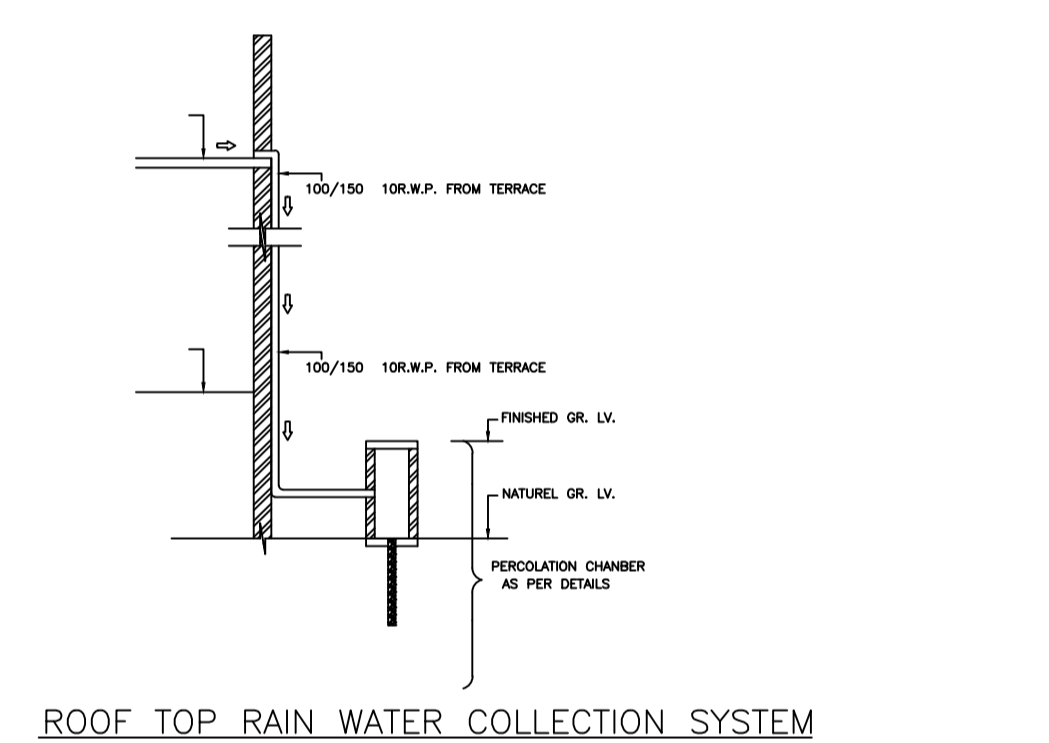

ROOF TOP RAIN WATER COLLECTION SYSTEM

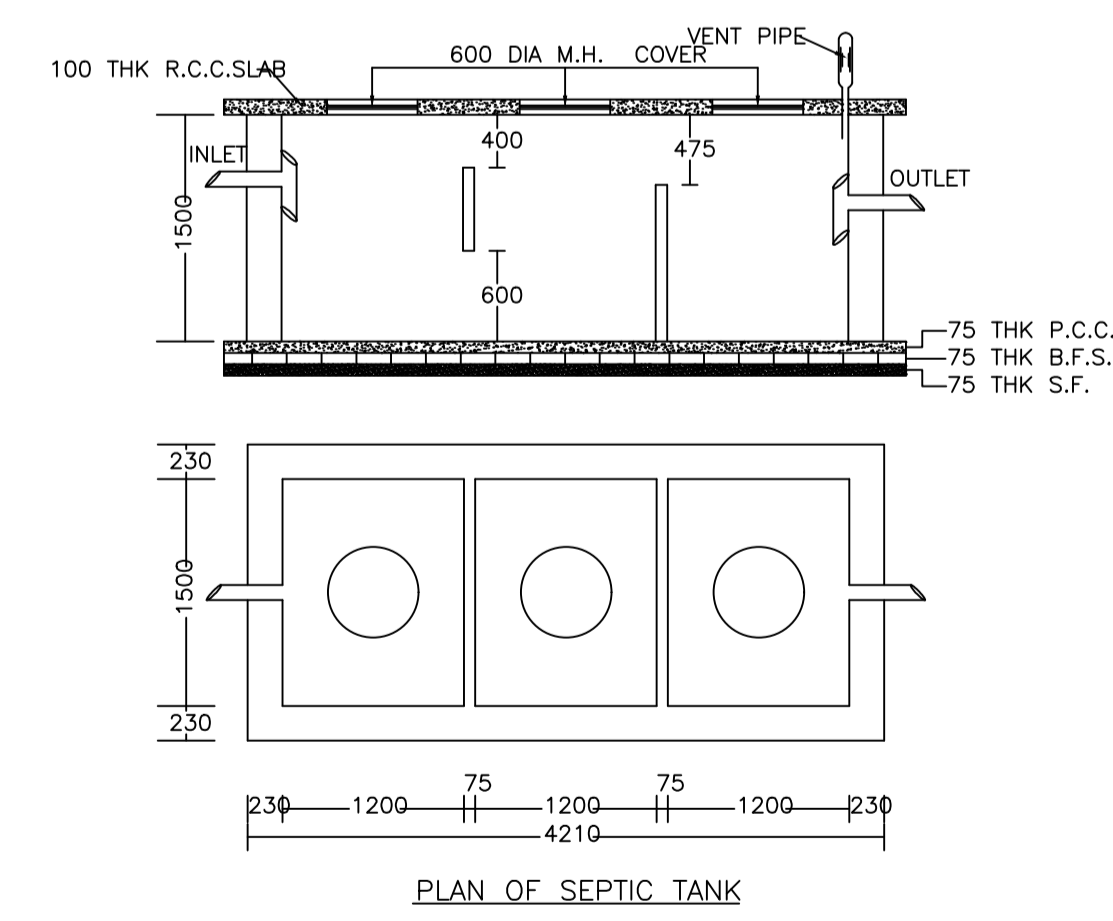

PLAN OF SEPTIC TANK

Proposal Basic Information

Proposal File No.	DMC/BP/0177/W28/2020
Owner Name	Smt. Rashmi Sinha
Khata No	68
Plot No	447
Village Name	Hirapur
Use	Residential
SubUse	Bungalow/ Dwelling / Non Apartment

AREA STATEMENT

VERSION NO.:	1.0.46
VERSION DATE:	22/06/2020
Region:	JHARKHAND
Urban Local Bodies:	Plot Use: Residential
District:	DHANBAD
Authority:	DHANBAD MUNICIPAL CORPORATION
Inward No.:	DMC/BP/0177/W28/2020
Application Type:	General Proposal
Project Type:	Building Permission
Nature of Development:	New
Location of Development Area:	Old Area
AREA OF PLOT (Minimum)	(A) 485.03
Deduction for NetPlot Area	
Surrender Free of Cost	6.87
Total	6.87
NET AREA OF PLOT (Gross Plot Area - Deduction from Gross Plot area)	(A-Deductions) 478.16
Deduction for Balance Plot Area (from Gross Plot Area)	
Surrender Free of Cost	6.87
Total	6.87
BALANCE AREA OF PLOT (Net Plot Area - Recreational/Amenity space)	(A-Deductions) 397.44
PLOT AREA FOR COVERAGE (Net Plot Area)	(A-Deductions) 478.16
Plot Area for FAR (Net Plot Area + Road Widening Area)	(A-Deductions) 485.03
COVERAGE CHECK	
Permissible Coverage area (60.00 %)	286.90
Proposed Coverage Area (29.12 %)	139.26
Total Prop. Coverage Area (29.12 %)	139.26
Balance coverage area (30.88 %)	147.64
FAR CHECK	
Perm. FAR Area (1.20)	582.04
Total Perm. FAR area	582.04
Residential FAR	278.51
Proposed FAR Area	278.51
Total Proposed FAR Area	278.51
Consumed FAR (Factor)	0.57
Balance FAR Area	303.53
BUILT UP AREA CHECK	
Total Proposed BuiltUp Area	278.52
ARCHITECT (Regd)	PIYUSH KANTI SINGH
ENGINEER (Regd)	
SUPERVISOR (Regd)	
OWNER (Regd)	Smt. Rashmi Sinha
DEVELOPMENT AUTHORITY	LOCAL BODY

FAR & Tenement Details (Table 4c-1)

Building	No. of Same Bldg	Total Built Up Area (Sq.mt.)	Proposed FAR Area (Sq.mt.)	Total FAR Area (Sq.mt.)	Total Consumed Additional FAR Area (Sq.mt.)	Tnmt (No.)
A (MRS RASHMI SINHA)	1	278.52	278.52	278.52	278.52	01
Grand Total :	1	278.52	278.52	278.52	278.52	01

SCHEDULE OF DOOR:

BUILDING NAME	NAME	LENGTH	HEIGHT	NOS
A (MRS RASHMI SINHA)	D2	0.75	2.10	07
A (MRS RASHMI SINHA)	D1	0.90	2.10	01
A (MRS RASHMI SINHA)	D	1.00	2.10	07

Building USE/SUBUSE Details

Building Name	Building Use	Building SubUse	Building Structure
A (MRS RASHMI SINHA)	Residential	Bungalow/ Dwelling / Non-Apartment	Non-Highrise

SCHEDULE OF WINDOW/VENTILATION:

BUILDING NAME	NAME	LENGTH	HEIGHT	NOS
A (MRS RASHMI SINHA)	V	0.60	0.60	05
A (MRS RASHMI SINHA)	W1	0.90	1.20	01
A (MRS RASHMI SINHA)	W	1.20	1.20	21

UnitBUA Table for Building :A (MRS RASHMI SINHA)

FLOOR	Name	UnitBUA Type	UnitBUA Area	Carpet Area	No. of Rooms	No. of Tenement
GROUND FLOOR PLAN	SPLIT 1	FLAT	278.51	278.35	8	1
FIRST FLOOR PLAN	SPLIT 1	FLAT	0.00	0.00	6	0
Total:	-	-	278.51	278.35	14	1

Floor Name	Total Built Up Area (Sq.mt.)	Proposed FAR Area (Sq.mt.)	Total FAR Area (Sq.mt.)	Total Consumed Additional FAR Area (Sq.mt.)	Tnmt (No.)
Ground Floor	139.26	139.26	139.26	139.26	01
First Floor	139.26	139.26	139.26	139.26	00
Terrace Floor	0.00	0.00	0.00	0.00	00
Total :	278.52	278.52	278.52	278.52	01
Total Number of Same Buildings	1				
Total :	278.52	278.52	278.52	278.52	01

COLOR INDEX

PLOT BOUNDARY	Black
ABUTTING ROAD	Green
PROPOSED CONSTRUCTION	Red
COMMON PLOT	Yellow
ROAD WIDENING AREA	Blue
EXISTING (To be retained)	Light Blue
EXISTING (To be demolished)	Light Yellow

Buildingwise Floor FAR Details

Floor Name	Building Name A (MRS RASHMI SINHA)		Total	
	Proposed Built Up Area (Sq.mt.)	Proposed FAR Area (Sq.mt.)	Total Proposed Built Up Area (Sq.mt.)	Total FAR Area (Sq.mt.)
Ground Floor	139.26	139.26	139.26	139.26
First Floor	139.26	139.26	139.26	139.26
Terrace Floor	0.00	0.00	0.00	0.00
Total :	278.52	278.52	278.52	278.52

LTP NAME AND SIGNATURE	STRUCTURAL ENG'S NAME AND SIGNATURE	SEAL AND SIGNATURE	DEVELOPER'S NAME AND SIGNATURE
PIYUSH KANTI SINGH DMC/ENG/0020/2016			

Proposal Basic Information	
Proposal File No	DMC/EP/0177/W28/2020
Owner Name	Smt. Rashmi Sinha
Khata No	68
Plot No	447
Village Name	Hirapur
Use	Residential
SubUse	Bungalow/ Dwelling / Non Apartment

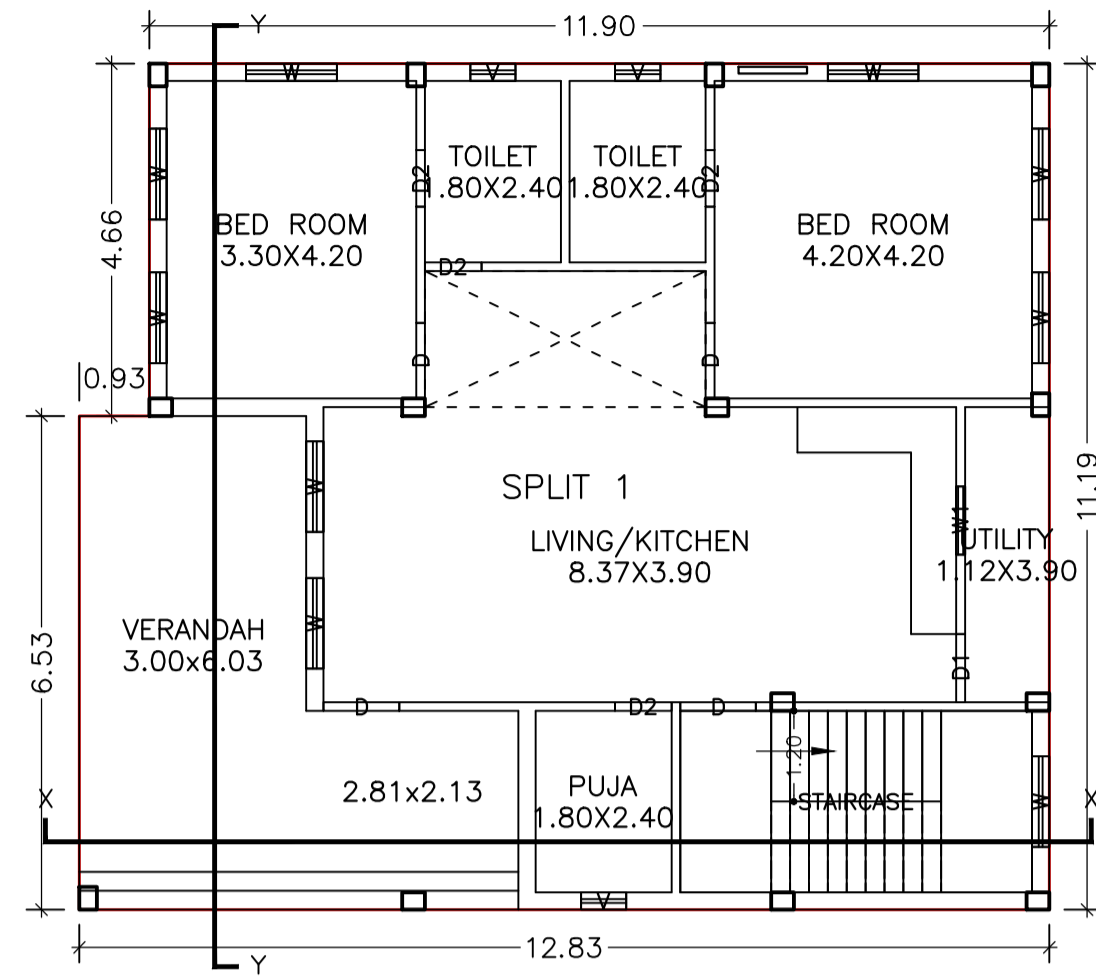

GROUND FLOOR PLAN
(Proposed)
(SCALE 1:100)

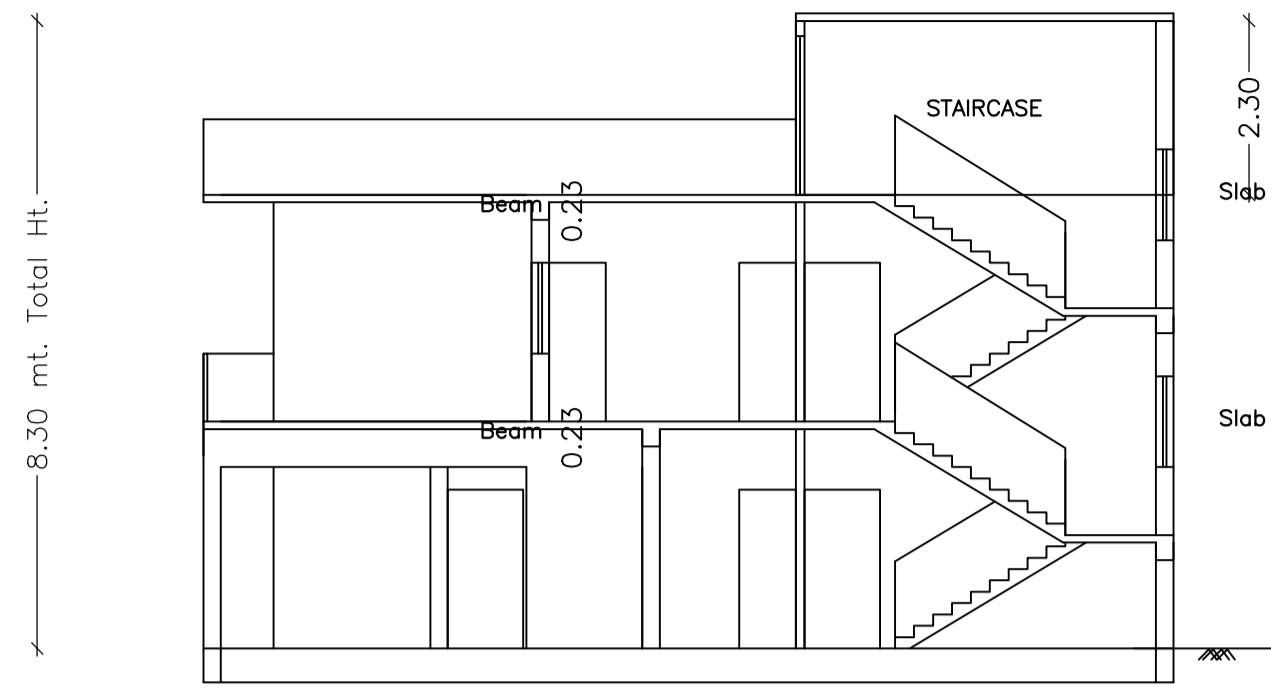

SECTION ON X-X

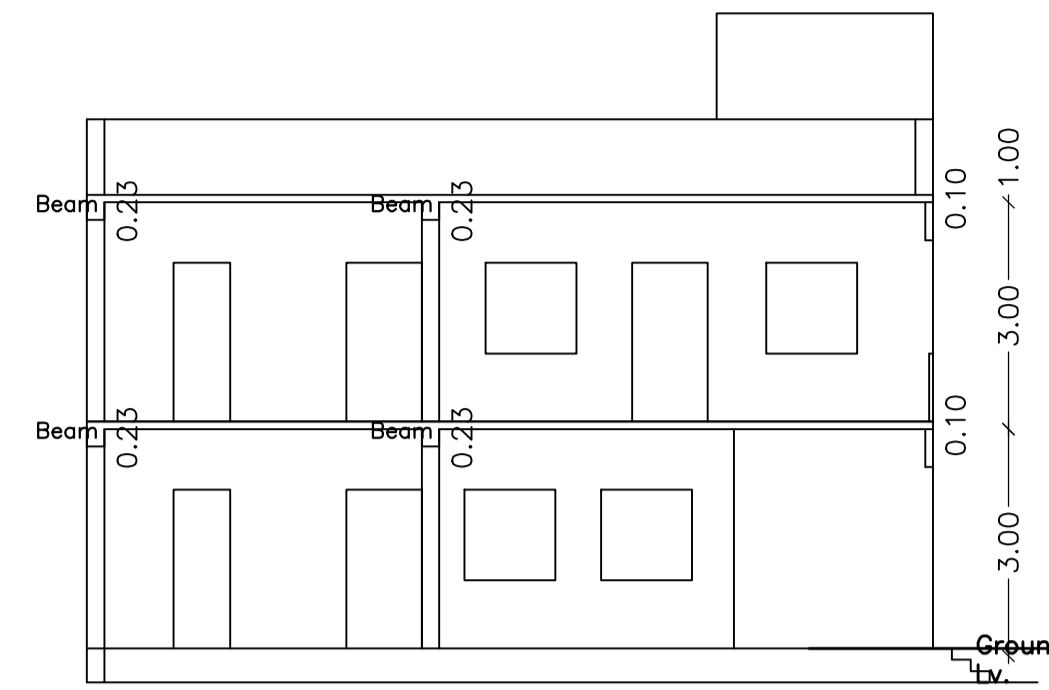

SECTION ON Y-Y

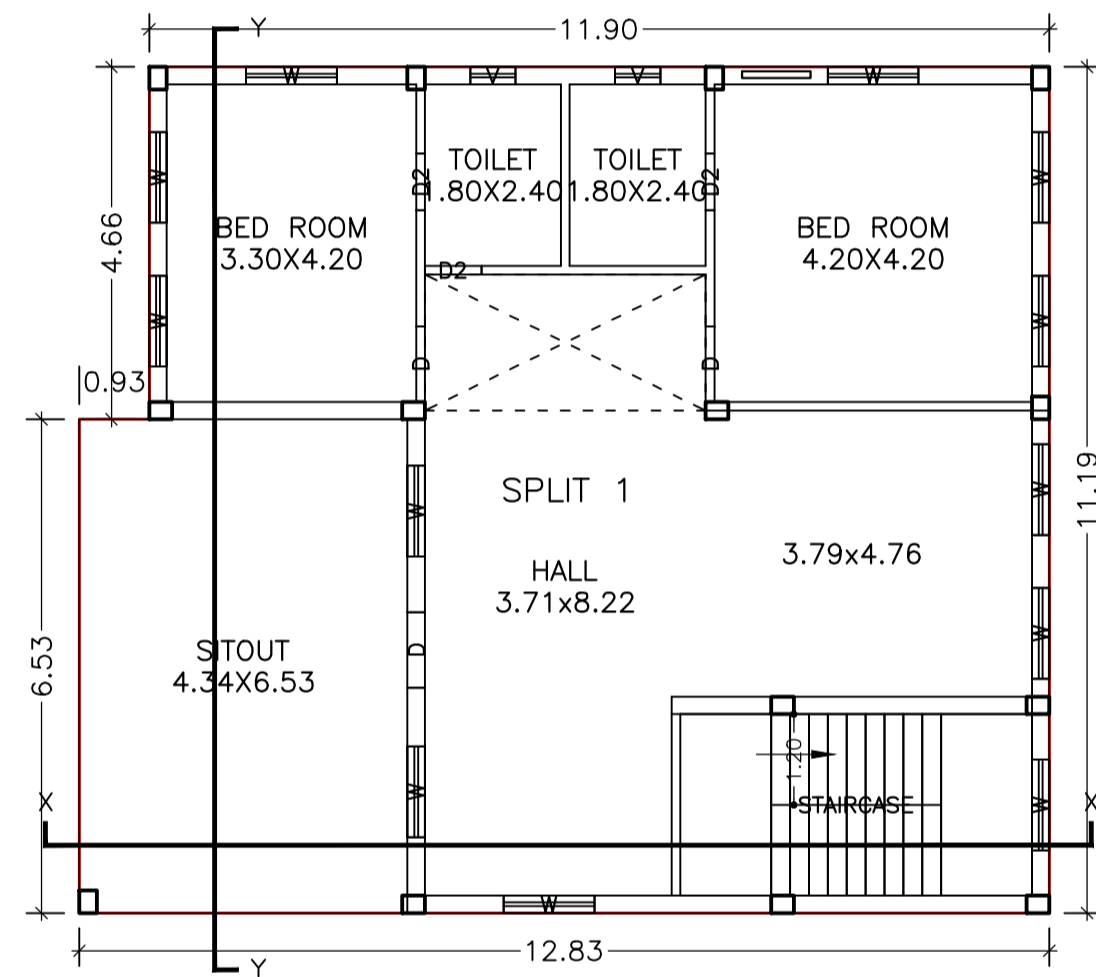

FIRST FLOOR PLAN
(Proposed)
(SCALE 1:100)

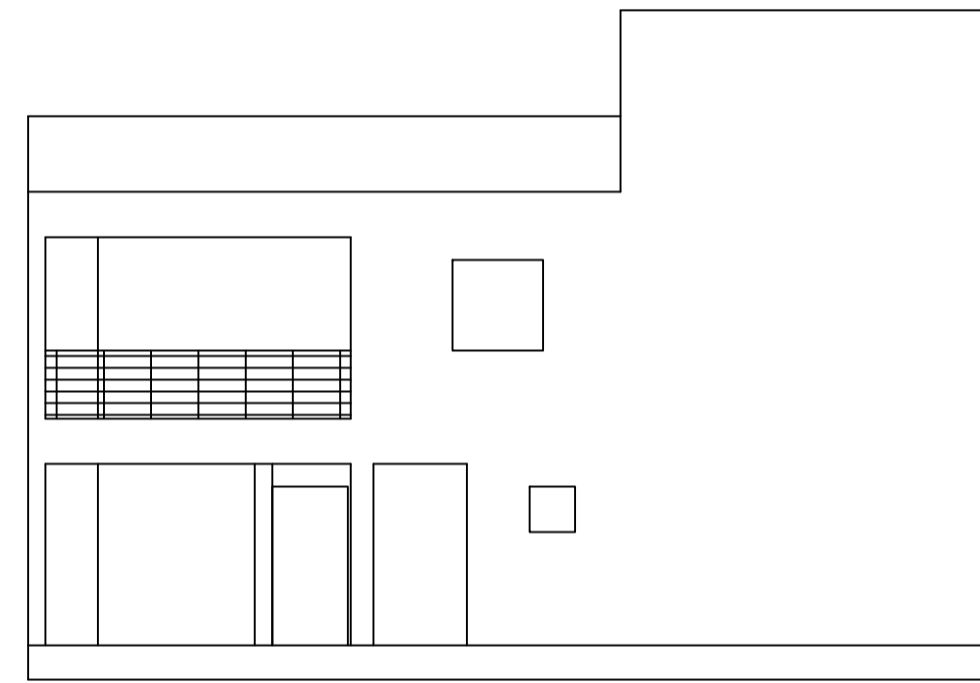

FRONT ELEVATION

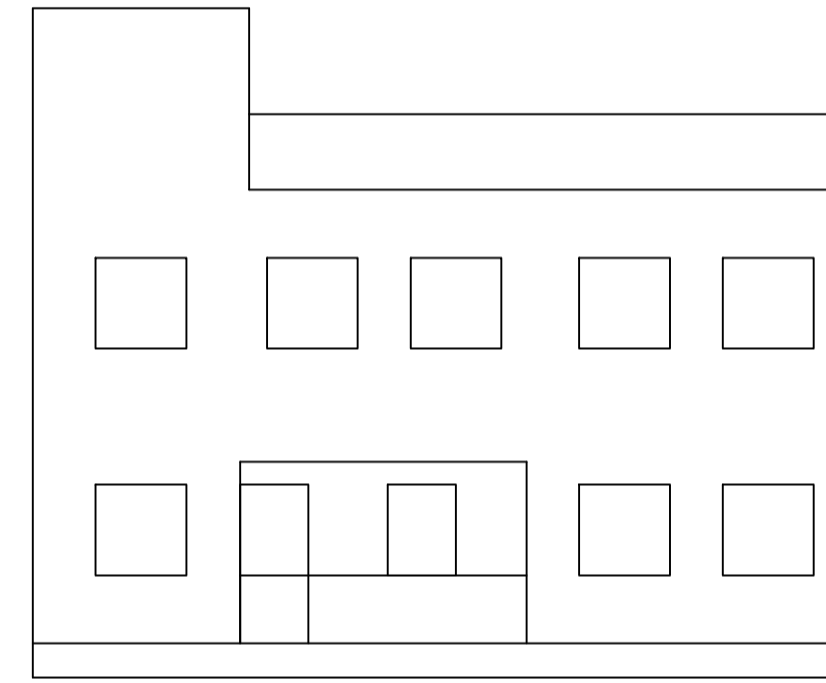

RIGHT SIDE ELEVATION

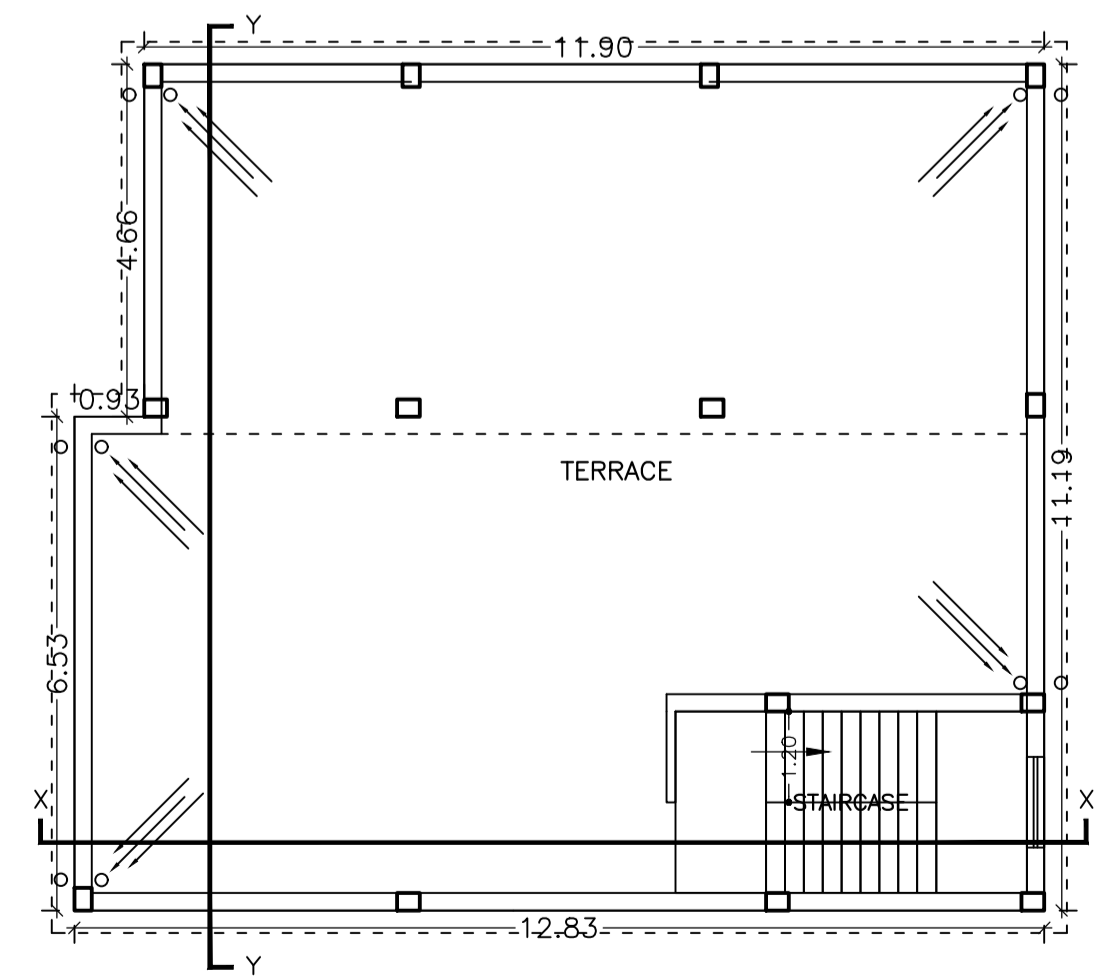

TERRACE FLOOR PLAN
(SCALE 1:100)

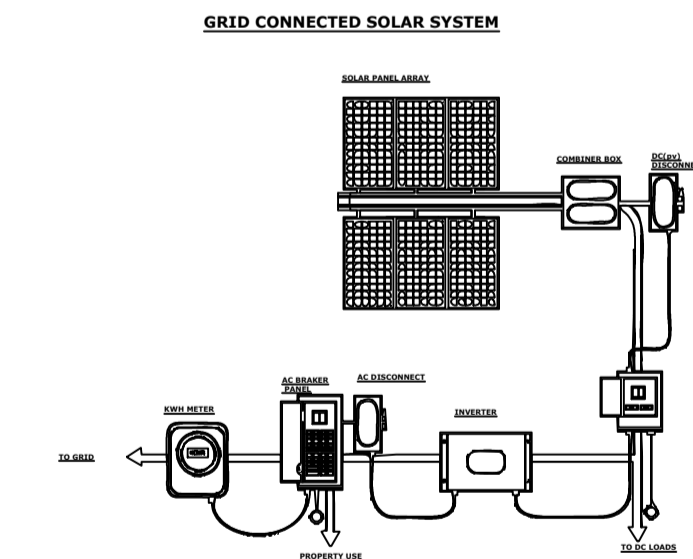
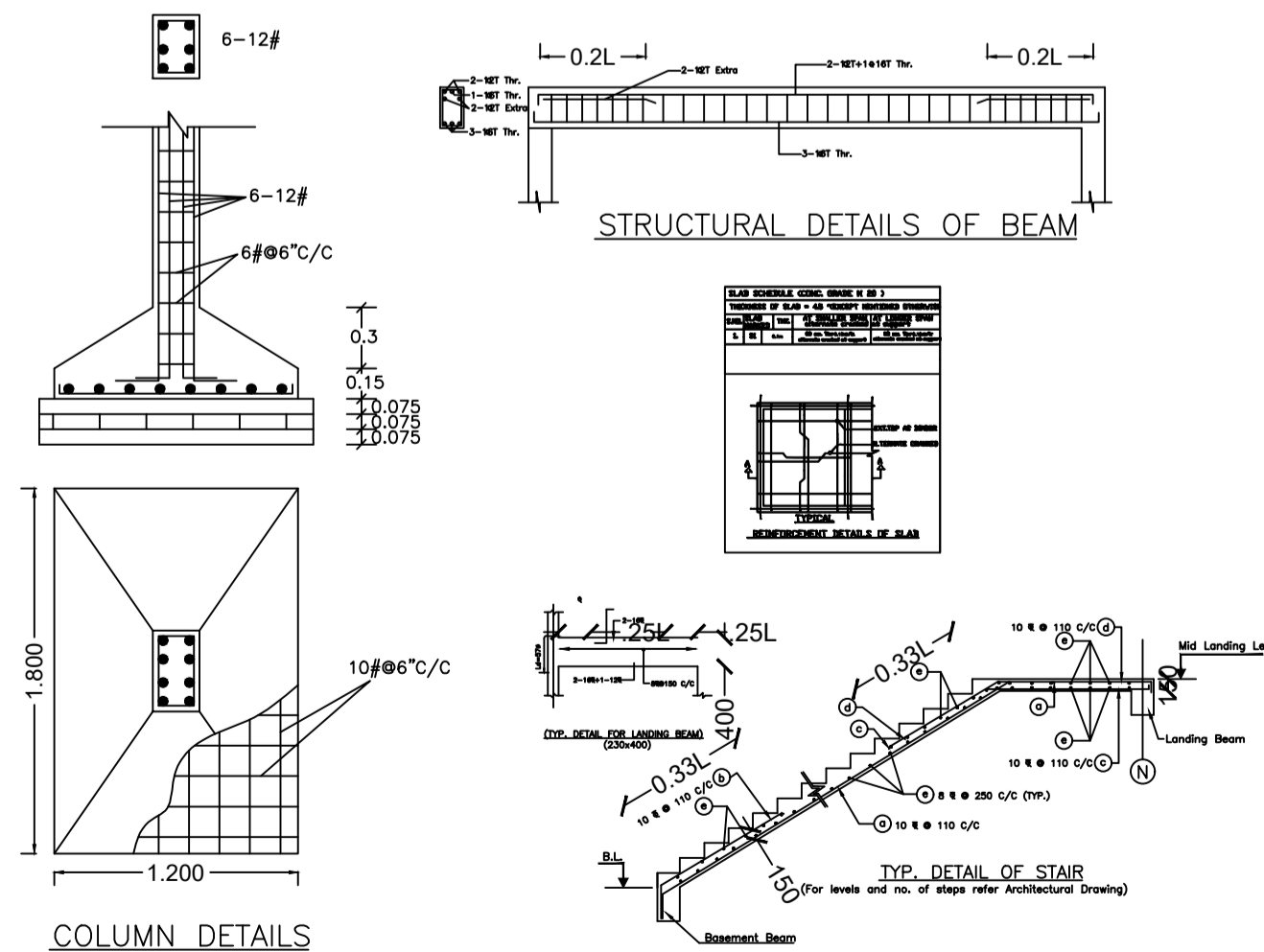

LTP NAME AND SIGNATURE	STRUCTURAL ENG'S NAME AND SIGNATURE	SIENNA/DERNAME AND SIGNATURE	DUREAL SIGNATURE
PIYUSH KANTI SINGH DMC/ENG/0020/2016			