

SECTION ON = X-X

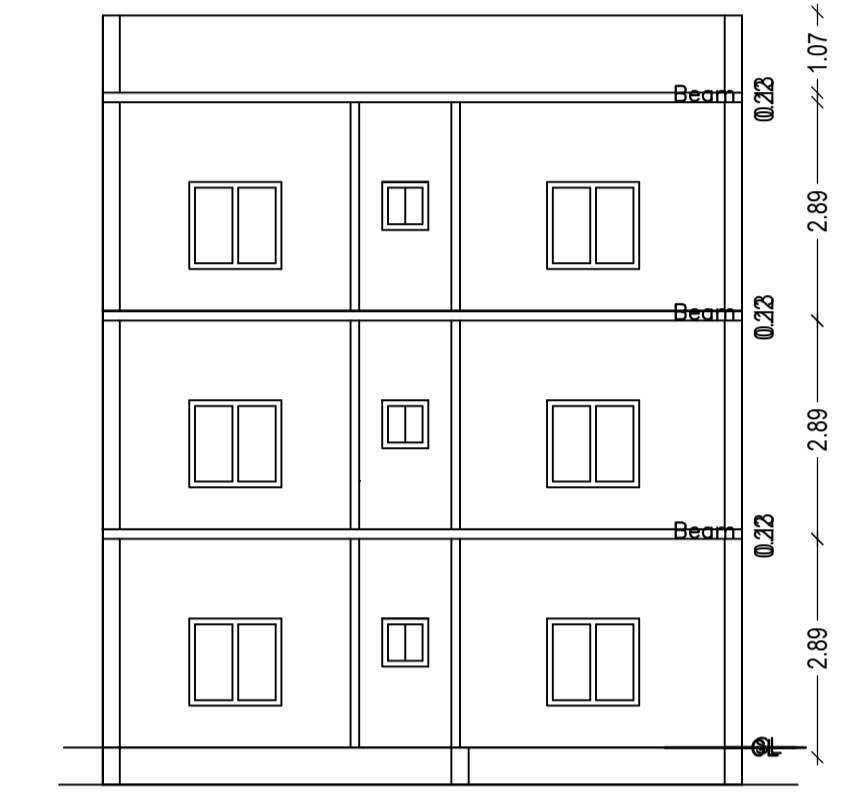

SECTION ON = Y-Y

Proposal Basic Information	
Proposal File No.	DMC/BP/0139/W20/2020
Owner Name	ABHILASHA KUMARI
Khata No	OLD - 01 & NEW - 111
Plot No	OLD - 76, 84 & NEW - 116
Village Name	Bisanpur
Use	Residential
SubUse	Bungalow/ Dwelling / Non Apartment

SITE PLAN

AREA STATEMENT		VERSION NO. : 1.0.50
DHANBAD MUNICIPAL CORPORATION		VERSION DATE: 16/10/2020
PROJECT DETAIL:		
Region: JHARKHAND URBAN LOCAL BODIES	Plot Use: Residential	
District: DHANBAD	Plot SubUse: Bungalow/ Dwelling / Non Apartment	
Authority: DHANBAD MUNICIPAL CORPORATION	PlotNearbyReligiousStructure: NA	
Inward No: DMC/BP/0139/W20/2020	Plot/SubPlot No: OLD - 76, 84 & NEW - 116	
Application Type: General Proposal	North: CTS No. - SMT. BEBY DEVI	
Project Type: Building Permission	South: Plot No. - OLD PLOT NO - 76	
Nature of Development: New	East: Road Width - 4.88	
Location of Development Area: Old Area	West: CTS No. - SMT. ASHA DEVI	
AREA DETAILS:		
AREA OF PLOT (Minimum)	(A)	SQ.MT. 126.96
Deduction for NetPlot Area		
Surrender Free of Cost		8.25
Total		8.25
NET AREA OF PLOT(Gross Plot Area - Deduction from Gross Plot area)	(A-Deductions)	118.71
Deduction for Balance Plot Area(from Gross Plot Area)		
Surrender Free of Cost		8.25
Common Plot		22.31
Total		30.56
BALANCE AREA OF PLOT(Net Plot Area - Recreational/Amenity spaces)	(A-Deductions)	96.40
PLOT AREA FOR COVERAGE(Net Plot Area)	(A-Deductions)	118.71
Plot Area for FAR (Net Plot Area + RoadWidening Area)	(A-Deductions)	126.96
COVERAGE CHECK		
Permissible Coverage area ( 70.00 % )		83.10
Proposed Coverage Area ( 62.17 % )		73.80
Total Prop. Coverage Area ( 62.17 % )		73.80
Balance coverage area ( 7.83 % )		9.30
FAR CHECK		
Perm. FAR Area ( 1.50 )		190.44
Total Perm. FAR area		190.44
Residential FAR		175.21
Proposed FAR Area		175.21
Total Proposed FAR Area		175.21
Consumed FAR (Factor)		1.38
Balance FAR Area		15.23
BUILT UP AREA CHECK		
Total Proposed BuiltUp Area		175.21
ARCHITECT (Regd)	PREM KUMAR SINGH	
ENGINEER (Regd)		
SUPERVISOR (Regd)		
OWNER (Regd)	ABHILASHA KUMARI	
DEVELOPMENT AUTHORITY		LOCAL BODY

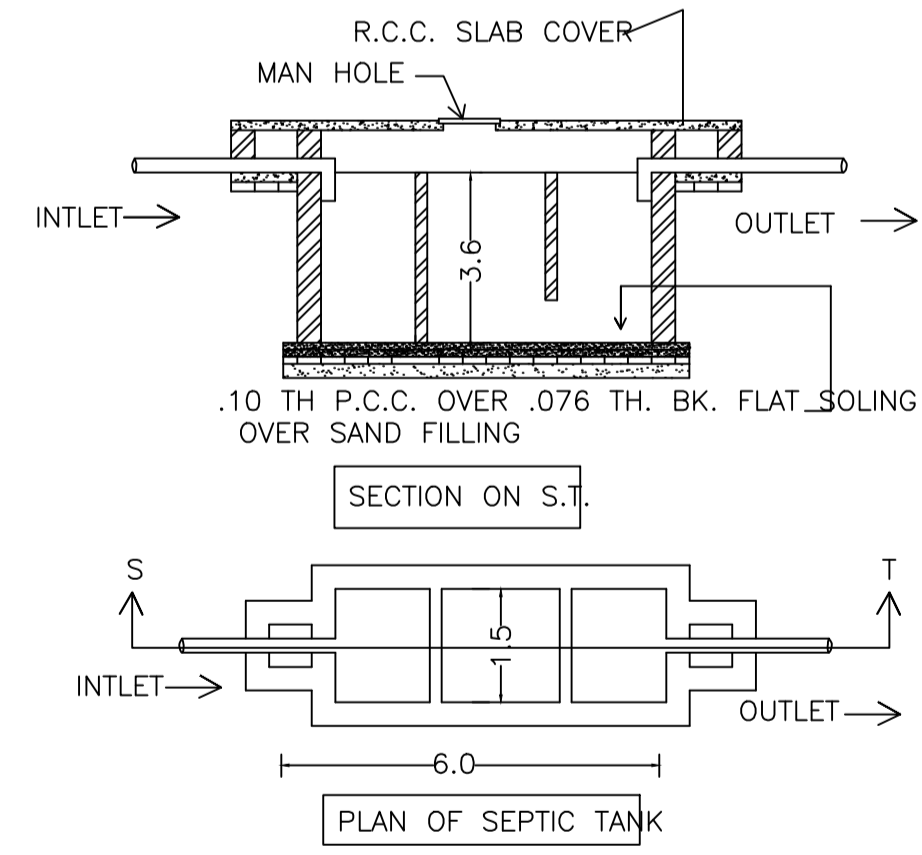

Building USE/SUBUSE Details

Building Name	Building Use	Building SubUse	Building Structure
A (SMT ABHILASHA KUMARI)	Residential	Bungalow/ Dwelling / Non Apartment	Non-Highrise

Buildingwise Floor FAR Details

Floor Name	Building Name A (SMT ABHILASHA KUMARI)		Total	
	Proposed Built Up Area (Sq.mt.)	Proposed FAR Area (Sq.mt.)	Total Proposed Built Up Area (Sq.mt.)	Total FAR Area (Sq.mt.)
Ground Floor	73.80	73.80	73.80	73.80
First Floor	73.80	73.80	73.80	73.80
Second Floor	27.61	27.61	27.61	27.61
Terrace Floor	0.00	0.00	0.00	0.00
Total	175.21	175.21	175.21	175.21

COLOR INDEX

PLOT BOUNDARY	Black
ABUTTING ROAD	Green
PROPOSED CONSTRUCTION	Red
COMMON PLOT	Yellow
ROAD WIDENING AREA	Orange
EXISTING (To be retained)	Blue
EXISTING (To be demolished)	Light Blue

FAR & Tenement Details (Table 4c-1)

Building	No. of Same Bldg	Total Built Up Area (Sq.mt.)	Proposed FAR Area (Sq.mt.)	Total FAR Area (Sq.mt.)	Total Consumed Additional FAR Area (Sq.mt.)	Tnmt (No.)
A (SMT ABHILASHA KUMARI)	1	175.21	175.21	175.21	175.21	01
Grand Total :	1	175.21	175.21	175.21	175.21	01

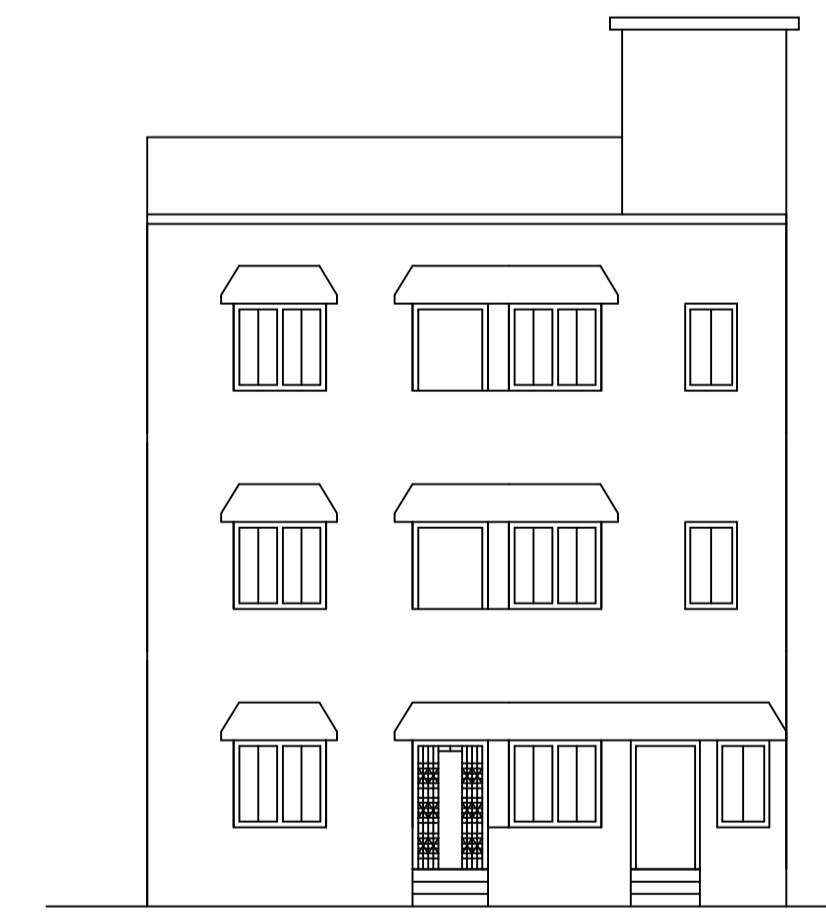
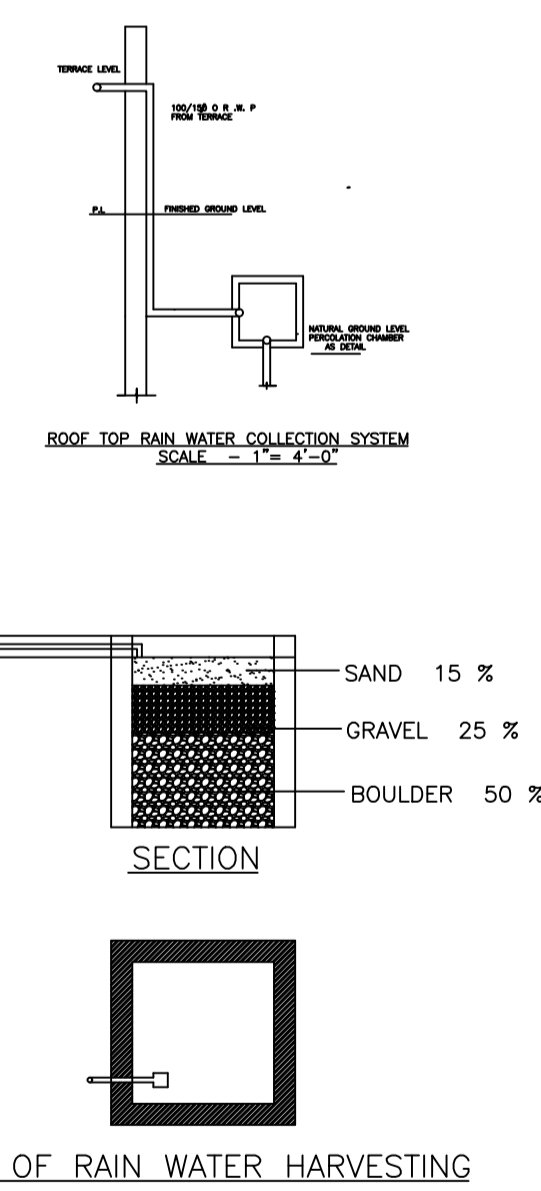

FRONT ELEVATION

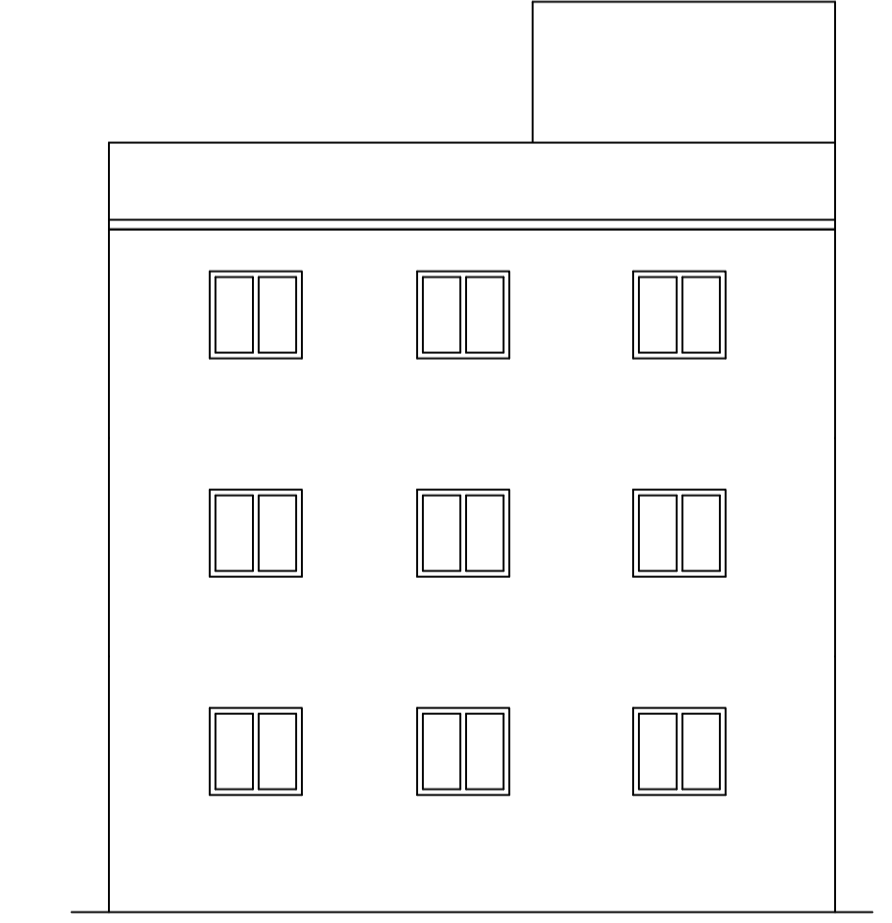

LEFT SIDE ELEVATION

LTP NAME AND SIGNATURE	STRUCTURAL ENG'S NAME AND SIGNATURE	BUILDER NAME AND SIGNATURE	DIGITAL SIGNATURE
PREM KUMAR SINGH DMC/ENG/0018/2016			

Proposal Basic Information

Proposal File No.	DMC/BP/0139/W20/2020
Owner Name	ABHILASHA KUMARI
Khata No	OLD - 01 & NEW - 111
Plot No	OLD - 76 , 84 & NEW - 116
Village Name	Bisanpur
Use	Residential
SubUse	Bungalow/ Dwelling / Non Apartment

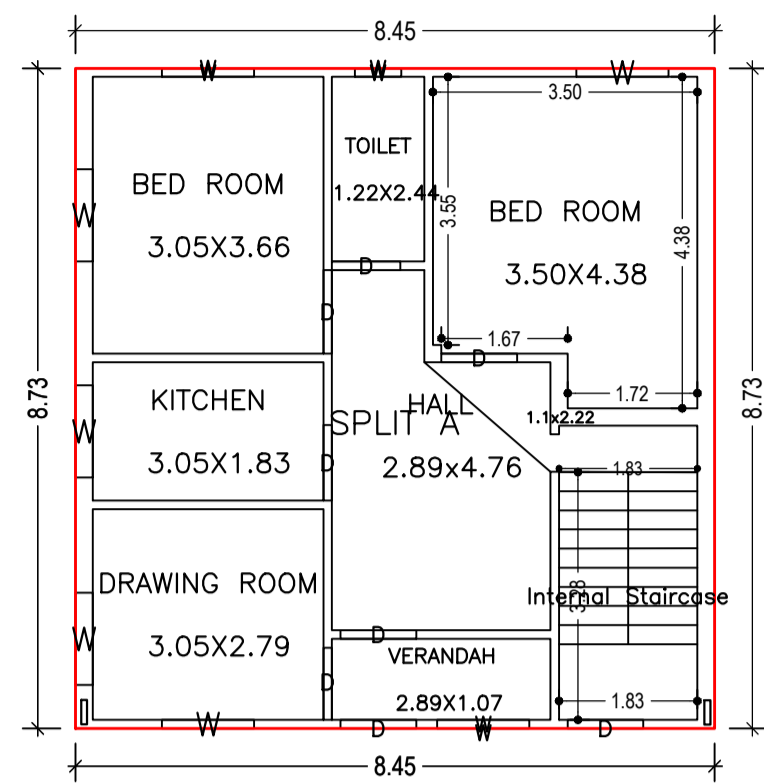

GROUND FLOOR PLAN  
(Proposed)  
(SCALE 1:100)

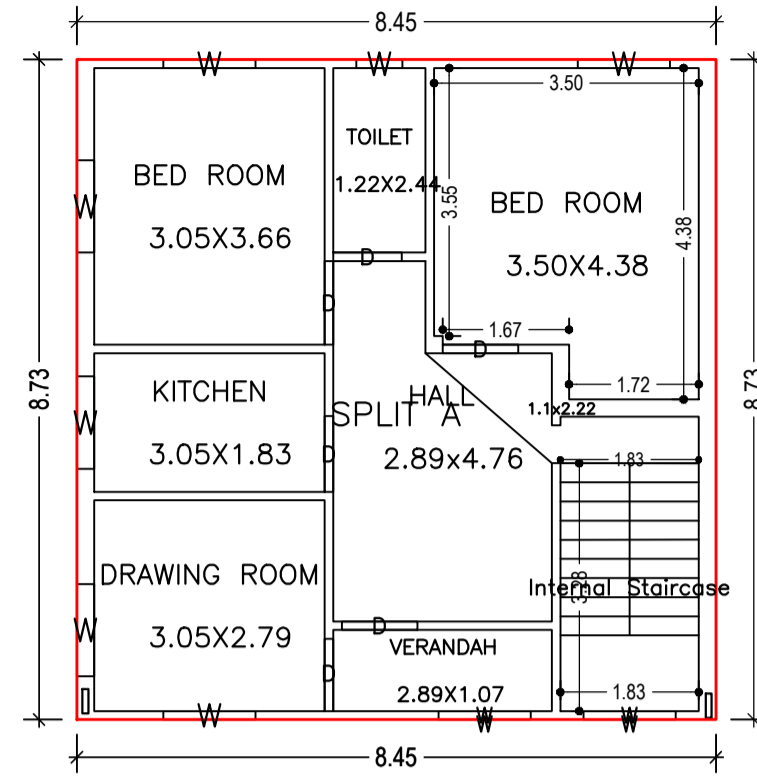

FIRST FLOOR PLAN  
(Proposed)  
(SCALE 1:100)

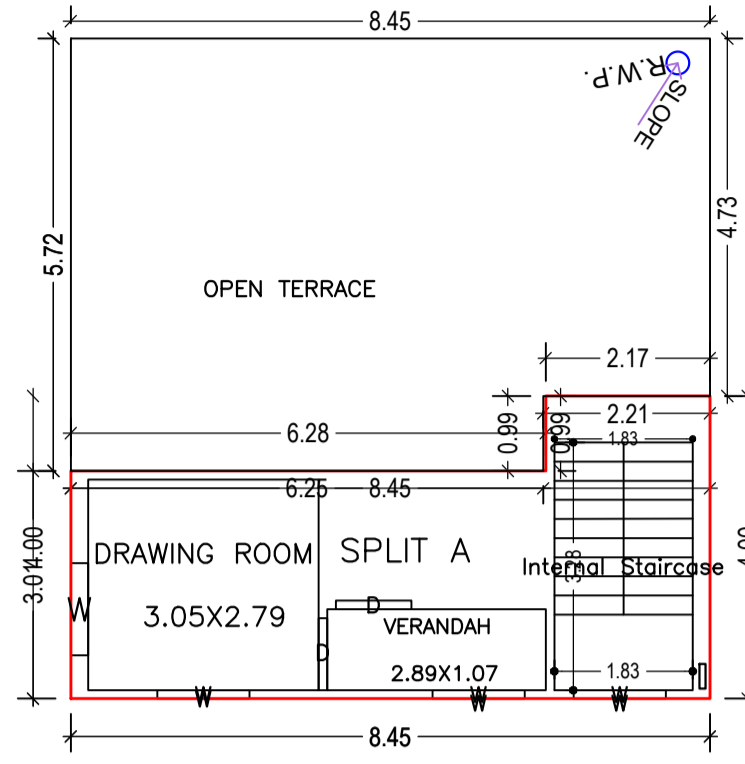

SECOND FLOOR PLAN  
(Proposed)  
(SCALE 1:100)

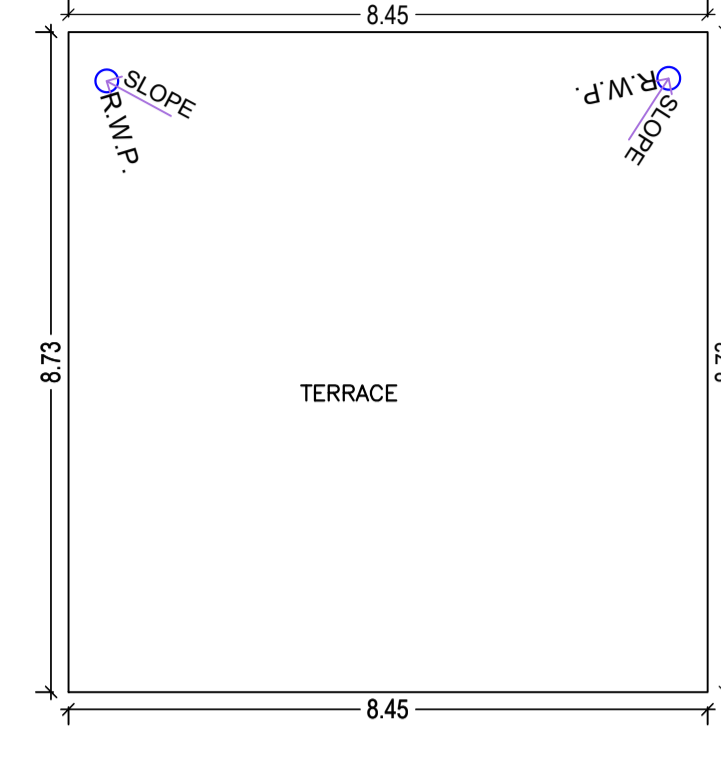

TERRACE FLOOR PLAN  
(SCALE 1:100)

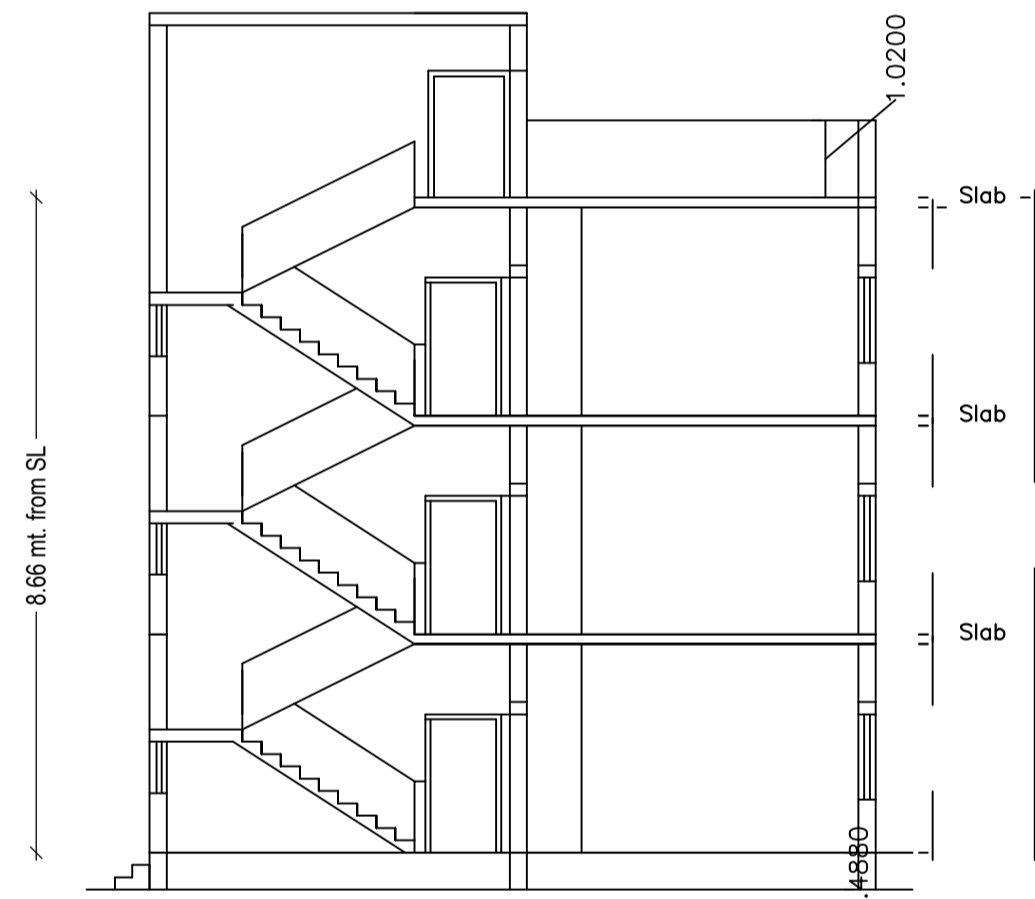
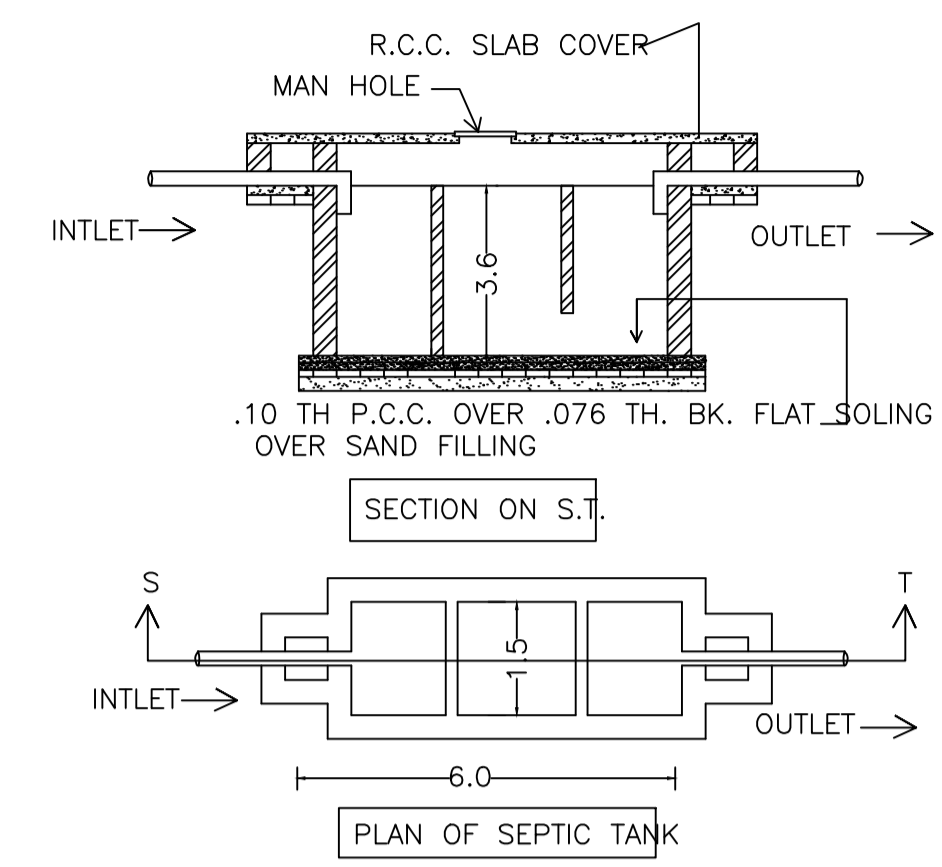

SECTION ON = X-X

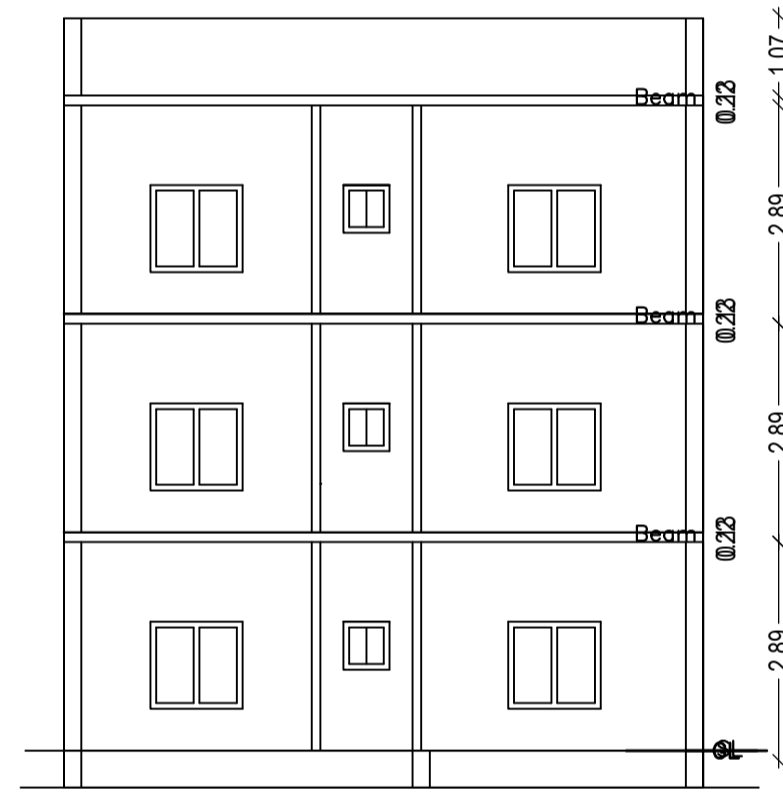

SECTION ON = Y-Y

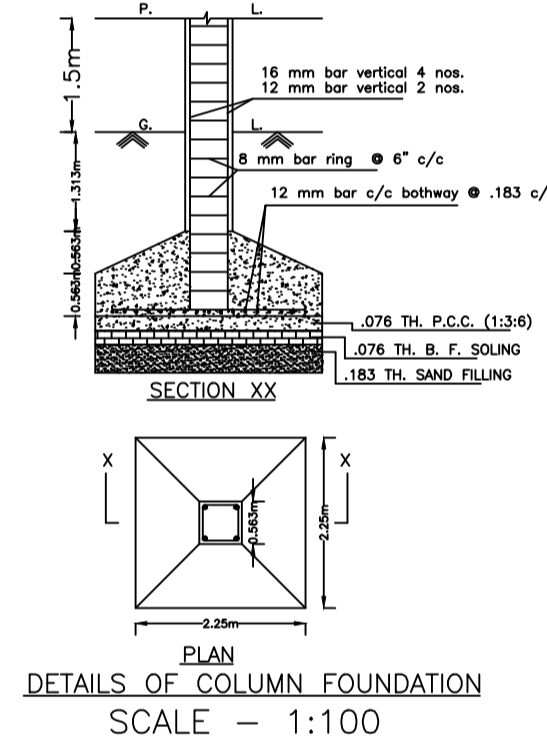

DETAILS OF COLUMN FOUNDATION  
SCALE - 1:100

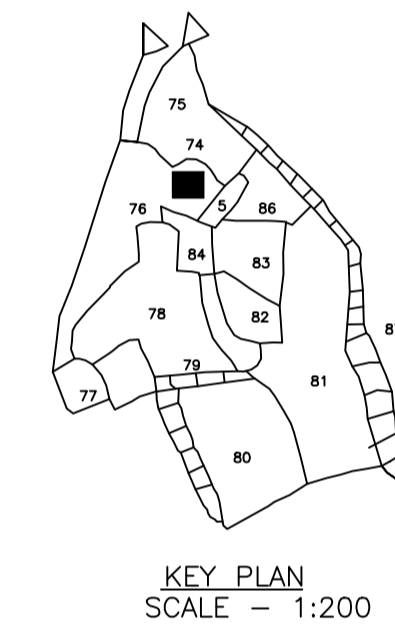

KEY PLAN  
SCALE - 1:200

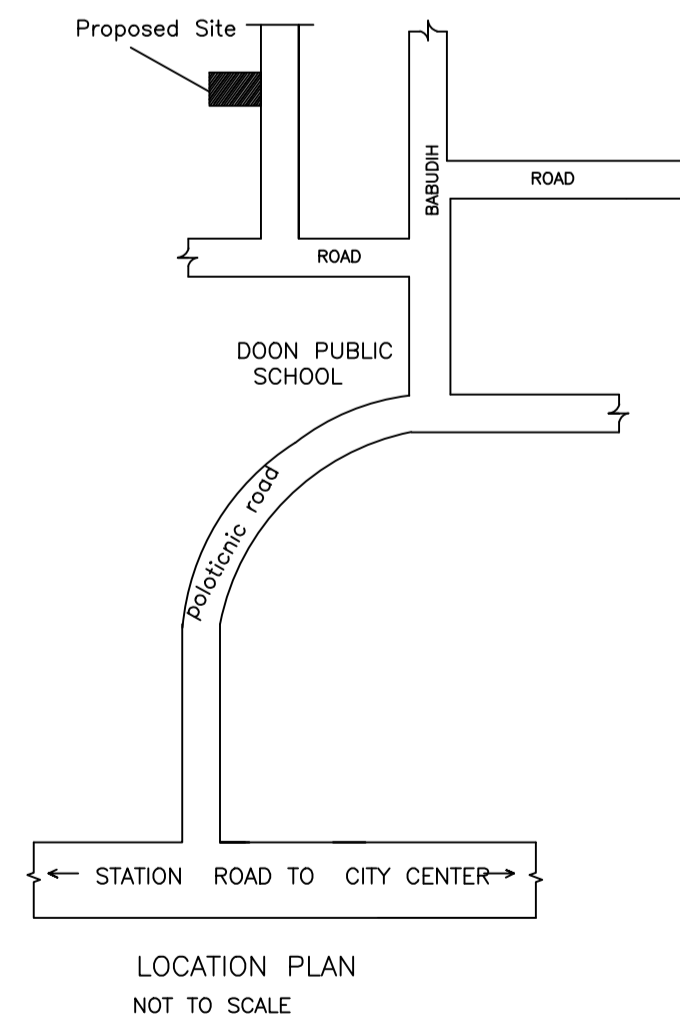

LOCATION PLAN  
NOT TO SCALE

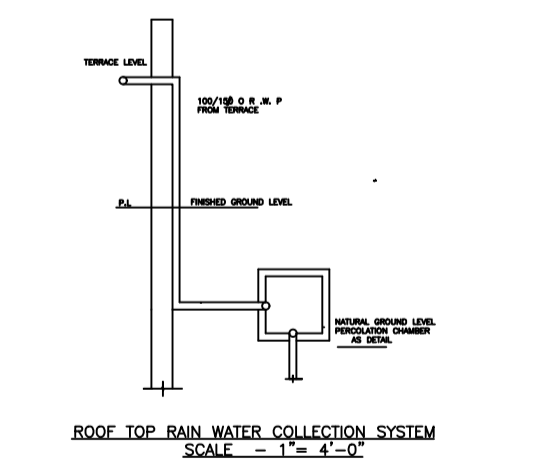

ROOF TOP RAIN WATER COLLECTION SYSTEM  
SCALE - 1"= 4'-0"

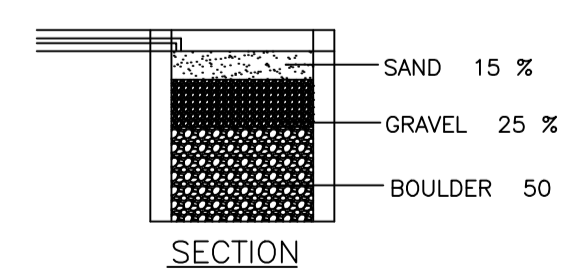

SECTION

PLAN OF RAIN WATER HARVESTING

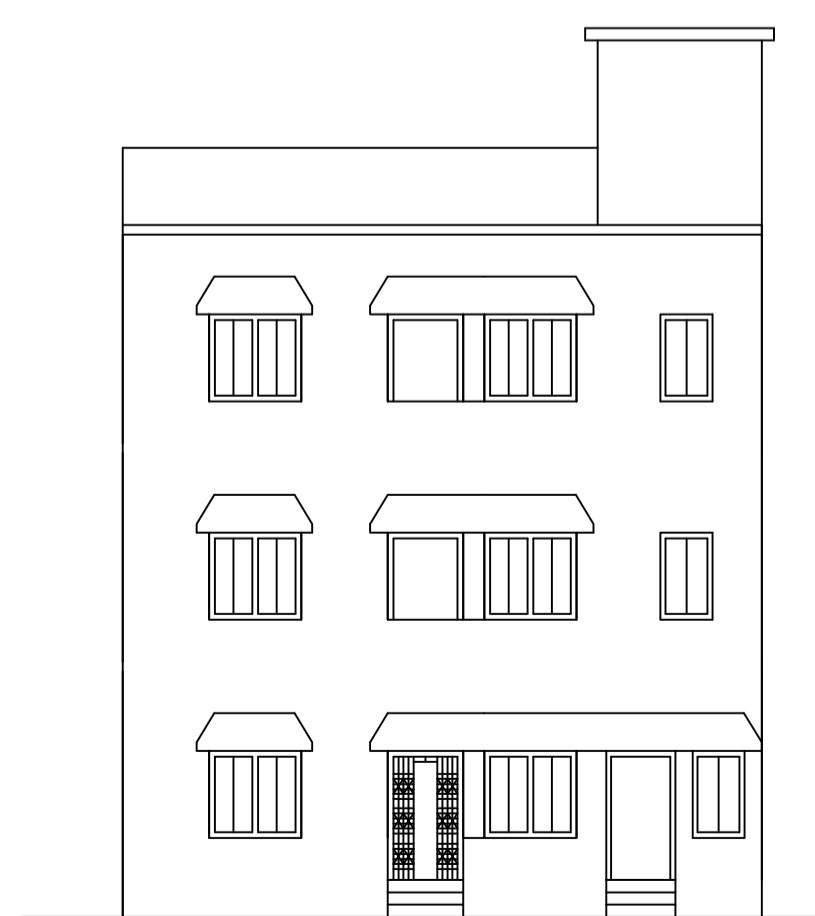

FRONT ELEVATION

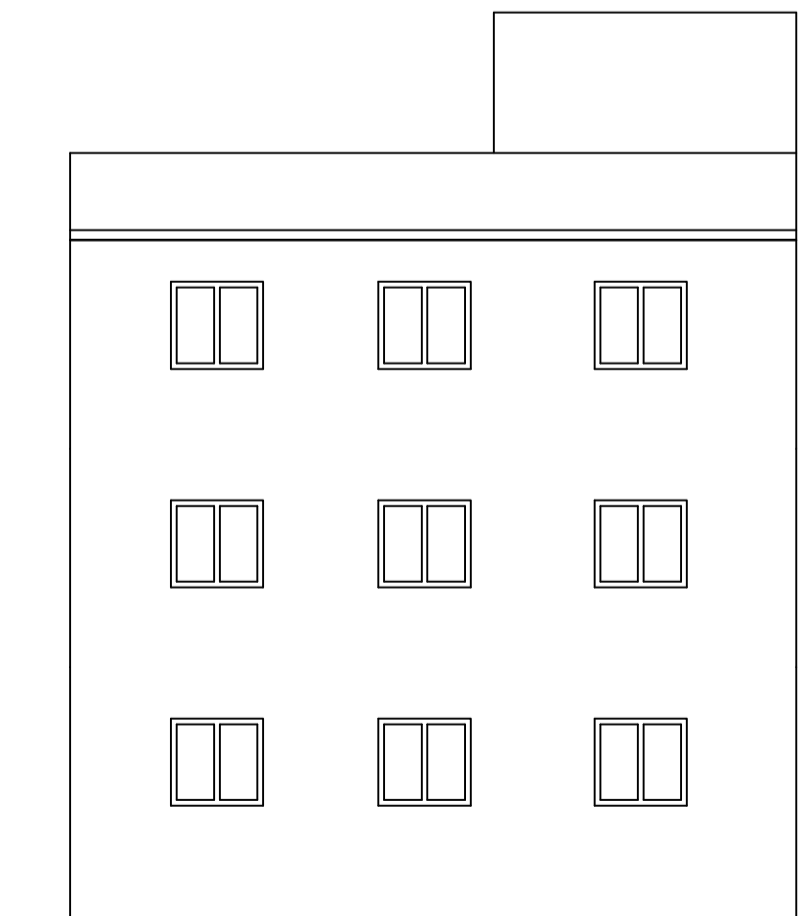

LEFT SIDE ELEVATION

Building :A (SMT ABHILASHA KUMARI)

Floor Name	Total Built Up Area (Sq.mt.)	Proposed FAR Area (Sq.mt.) Resi.	Total FAR Area (Sq.mt.)	Total Consumed Additional FAR Area (Sq.mt.)	Tnmt (No.)
Ground Floor	73.80	73.80	73.80	73.80	01
First Floor	73.80	73.80	73.80	73.80	00
Second Floor	27.61	27.61	27.61	27.61	00
Terrace Floor	0.00	0.00	0.00	0.00	00
Total :	175.21	175.21	175.21	175.21	01
Total Number of Same Buildings	1				
Total :	175.21	175.21	175.21	175.21	01

SCHEDULE OF DOOR:

BUILDING NAME	NAME	LENGTH	HEIGHT	NOS
A (SMT ABHILASHA KUMARI)	D	0.91	2.10	02
A (SMT ABHILASHA KUMARI)	D	0.95	2.10	03
A (SMT ABHILASHA KUMARI)	D	1.00	2.10	08
A (SMT ABHILASHA KUMARI)	D	1.11	2.10	02

SCHEDULE OF WINDOW/VENTILATION:

BUILDING NAME	NAME	LENGTH	HEIGHT	NOS
A (SMT ABHILASHA KUMARI)	W	0.61	1.20	02
A (SMT ABHILASHA KUMARI)	W	1.22	1.20	19

UnitBUA Table for Building :A (SMT ABHILASHA KUMARI)

FLOOR	Name	UnitBUA Type	UnitBUA Area	Carpet Area	No. of Rooms	No. of Tenement
GROUND FLOOR PLAN	SPLIT A	FLAT	175.21	175.09	7	1
FIRST FLOOR PLAN	SPLIT A	FLAT	0.00	0.00	7	0
SECOND FLOOR PLAN	SPLIT A	FLAT	0.00	0.00	2	0
Total:	-	-	175.21	175.09	16	1

LTP NAME AND SIGNATURE	STRUCTURAL ENG'S NAME AND SIGNATURE	BUILDER NAME AND SIGNATURE	DIGITAL SIGNATURE
PREM KUMAR SINGH DMC/ENG/0018/2016			