

SITE PLAN

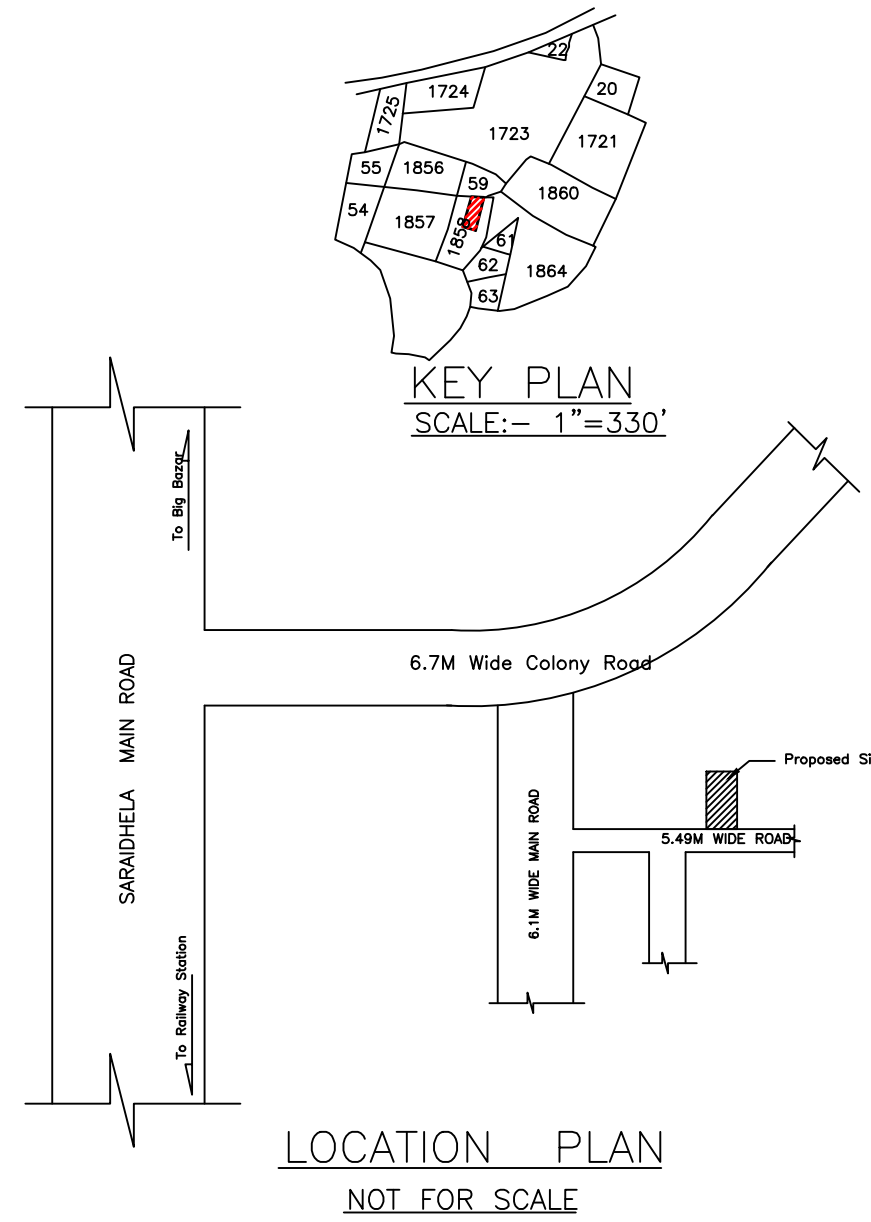

LOCATION PLAN
NOT FOR SCALE

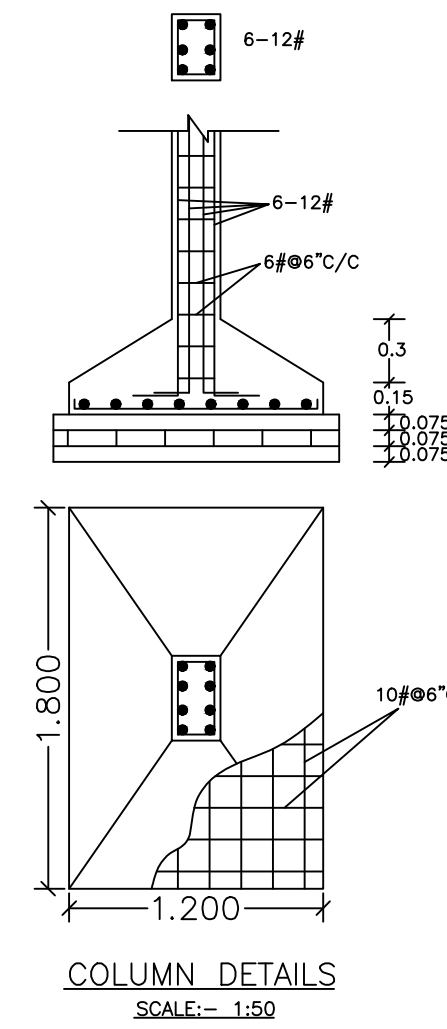

COLUMN DETAILS
SCALE:- 1/50

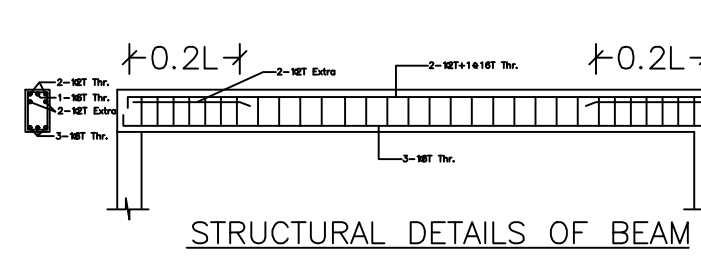

STRUCTURAL DETAILS OF BEAM

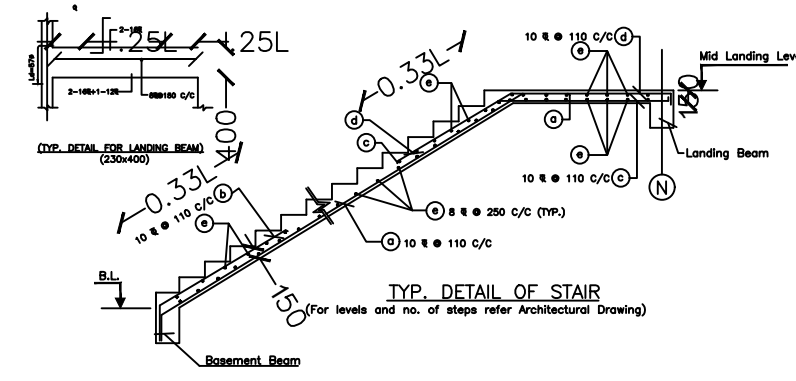

TYP. DETAIL OF STAIR

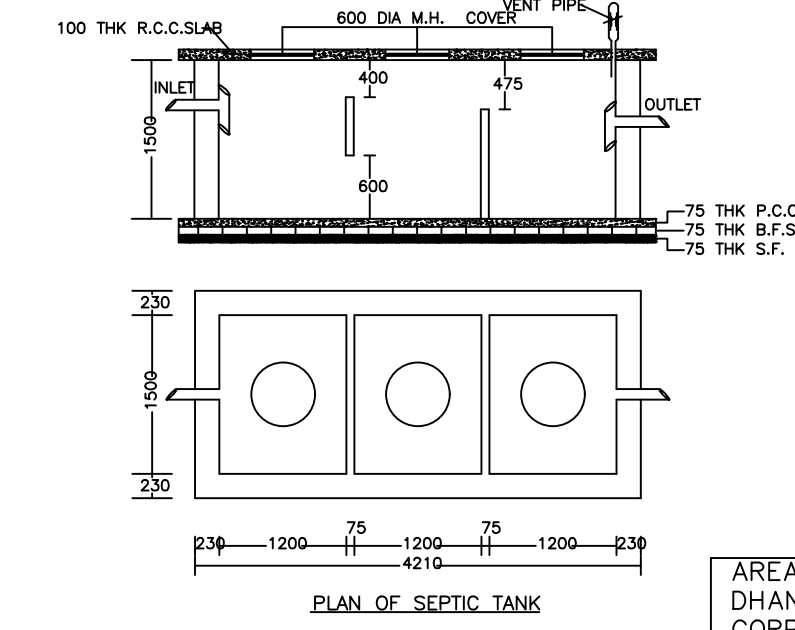

PLAN OF SEPTIC TANK

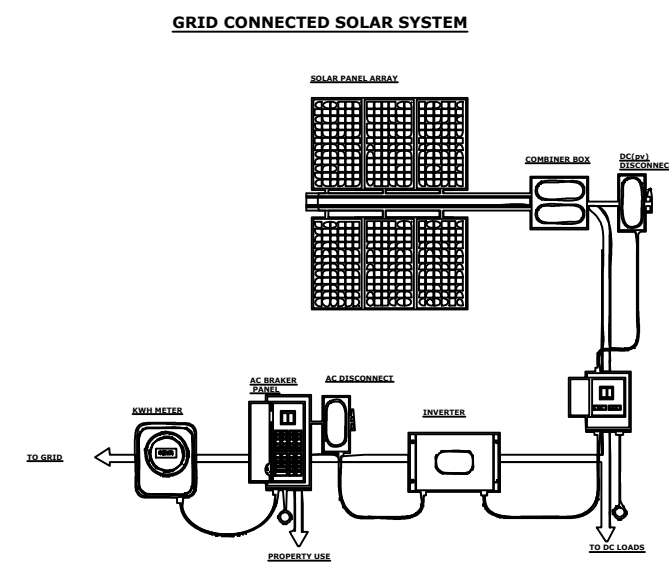

GRID CONNECTED SOLAR SYSTEM

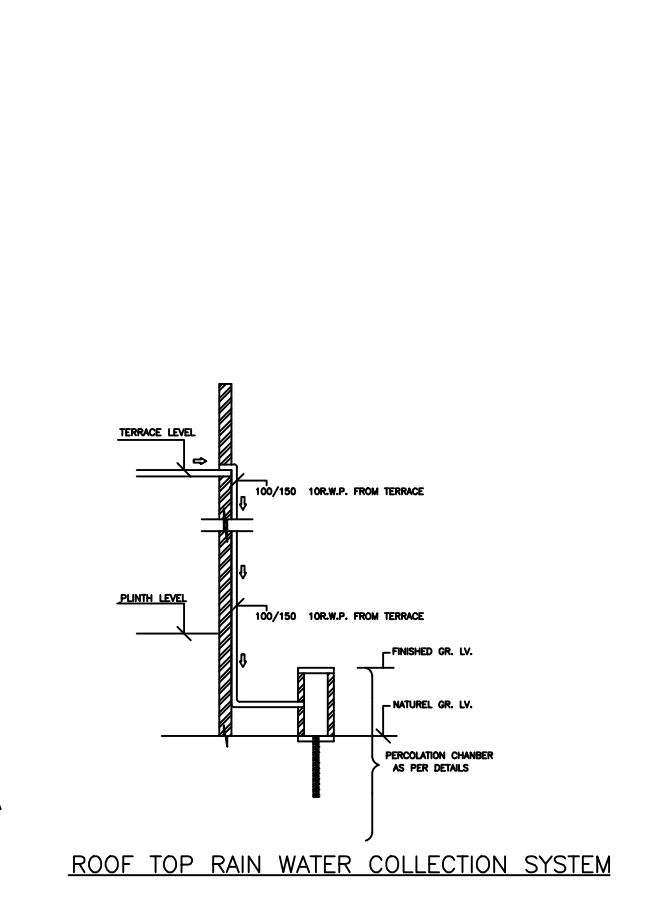

ROOF TOP RAIN WATER COLLECTION SYSTEM

Color and Basic Information	
Plot Boundary	DMC/BP/0170/W23/2020
Plot No	1858 (Old), New Plot No. - 2419
Village Name	Kolikusma
Use	Residential
SubUse	Bungalow/ Dwelling / Non Apartment

AREA STATEMENT	VERSION NO.: 1.0.48
DHANBAD MUNICIPAL CORPORATION	VERSION DATE: 22/06/2020
PROJECT DETAIL:	
Region: JHARKHAND URBAN LOCAL BODIES	Plot Use: Residential
District: DHANBAD	Plot SubUse: Bungalow/ Dwelling / Non Apartment
Authority: DHANBAD MUNICIPAL CORPORATION	PlotNearby/ReligiousStructure: NA
Inward_No: DMC/BP/0170/W23/2020	Plot/SubPlot No: 1858 (Old), New Plot No. - 2419
Application Type: General Proposal	North: Plot No. - OLD PLOT NO. 1859
Project Type: Building Permission	South: Road Width - 4.88 M WIDE ROAD
Nature of Development: New	East: Plot No. - PART OF OLD PLOT NO 1858
Location of Development Area: Old Area	West: Plot No. - PART OF OLD PLOT NO 1858
AREA DETAILS:	
AREA OF PLOT (Minimum)	(A) 87.60
NET AREA OF PLOT(Gross Plot Area - Deduction from Gross Plot area)	(A-Deductions) 87.60
Deduction for Balance Plot Area(from Gross Plot Area)	
Common Plot	15.04
Total	15.04
BALANCE AREA OF PLOT(Net Plot Area - Recreational/Amenity space)	(A-Deductions) 72.56
PLOT AREA FOR COVERAGE(Net Plot Area)	(A-Deductions) 87.60
Plot Area for FAR (Net Plot Area + RoadWidening Area)	(A-Deductions) 87.60
COVERAGE CHECK	
Permissible Coverage area (70.00 %)	61.32
Proposed Coverage Area (61.70 %)	54.05
Total Prop. Coverage Area (61.7 %)	54.05
Balance coverage area (8.30 %)	7.27
FAR CHECK	
Perm. FAR Area (1.80)	157.68
Total Perm. FAR area	157.68
Residential FAR	108.10
Proposed FAR Area	108.10
Total Proposed FAR Area	108.10
Consumed FAR (Factor)	1.23
Balance FAR Area	49.58
BUILT UP AREA CHECK	
Total Proposed BuiltUp Area	108.10
ARCHITECT (Regd)	PIYUSH KANTI SINGH
ENGINEER (Regd)	
SUPERVISOR (Regd)	
OWNER (Regd)	Sri. Shankar Prasad Singh and Others
DEVELOPMENT AUTHORITY LOCAL BODY	

UnitBUA Table for Building :A (SHANKAR PRASAD SINGH AND OTHERS)

FLOOR	Name	UnitBUA Type	UnitBUA Area	Carpet Area	No. of Rooms	No. of Tenement
GROUND FLOOR PLAN	SPLIT 1	FLAT	108.10	103.61	5	1
FIRST FLOOR PLAN	SPLIT 1	FLAT	0.00	0.00	6	0
Total:	-	-	108.10	103.61	11	1

Buildingwise Floor FAR Details

Floor Name	Building Name A (SHANKAR PRASAD SINGH AND OTHERS)		Total	
	Proposed Built Up Area (Sq.mt.)	Proposed FAR Area (Sq.mt.)	Total Proposed Built Up Area (Sq.mt.)	Total FAR Area (Sq.mt.)
Ground Floor	54.05	54.05	54.05	54.05
First Floor	54.05	54.05	54.05	54.05
Terrace Floor	0.00	0.00	0.00	0.00
Total :	108.10	108.10	108.10	108.10

FAR & Tenement Details (Table 4c-1)

Building	No. of Same Bldg	Total Built Up Area (Sq.mt.)	Proposed FAR Area (Sq.mt.) Resi.	Total FAR Area (Sq.mt.)	Total Consumed Additional FAR Area (Sq.mt.)	Tnmt (No.)
A (SHANKAR PRASAD SINGH AND OTHERS)	1	108.10	108.10	108.10	108.10	01
Grand Total :	1	108.10	108.10	108.10	108.10	01

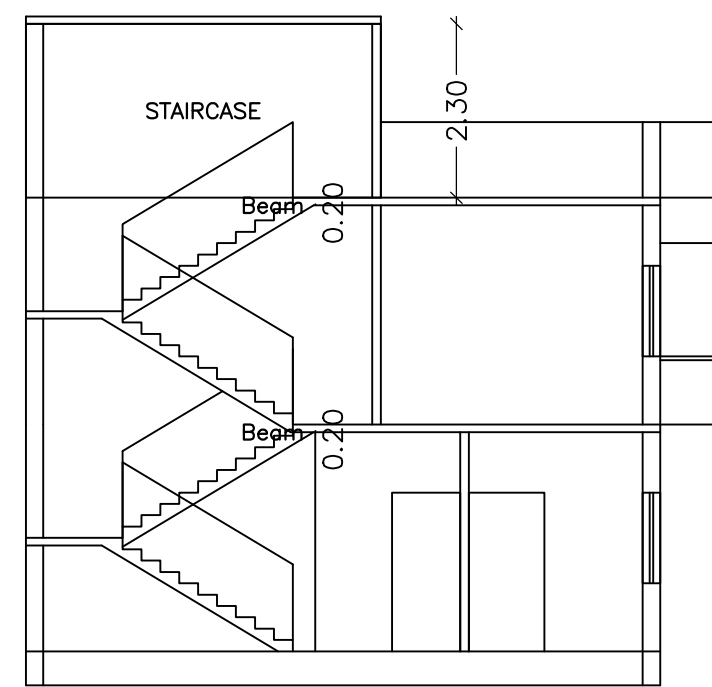

Section on X-X

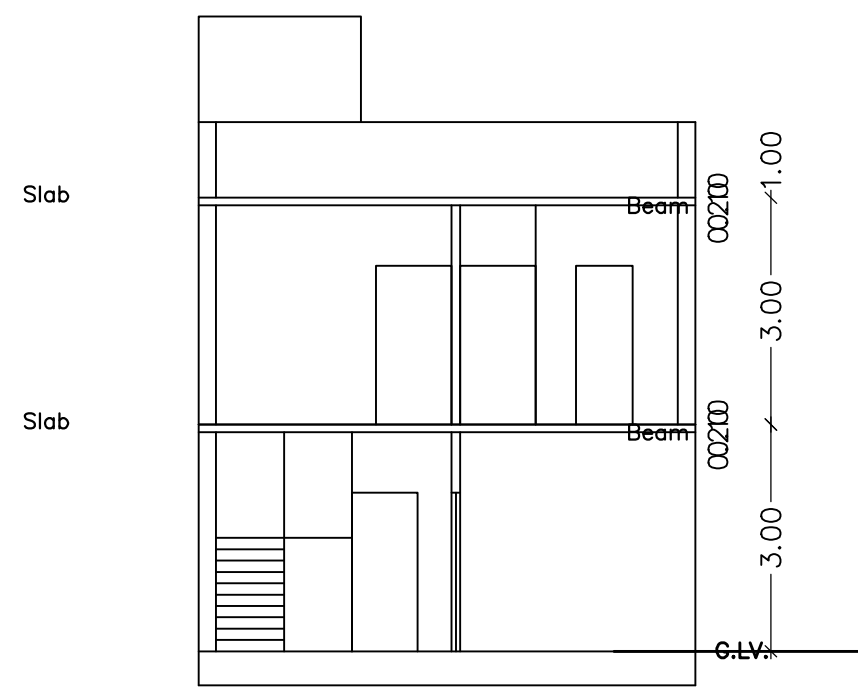

Section on Y-Y

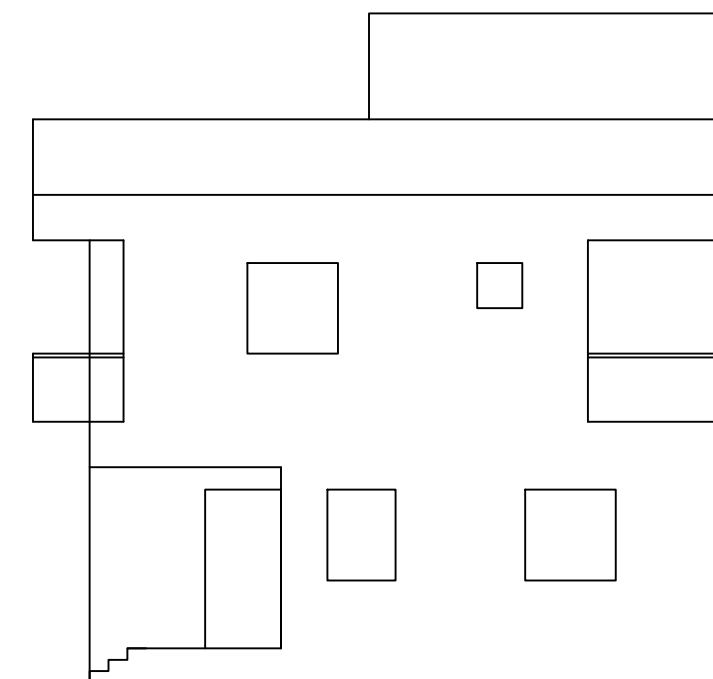

Right Side Elevation

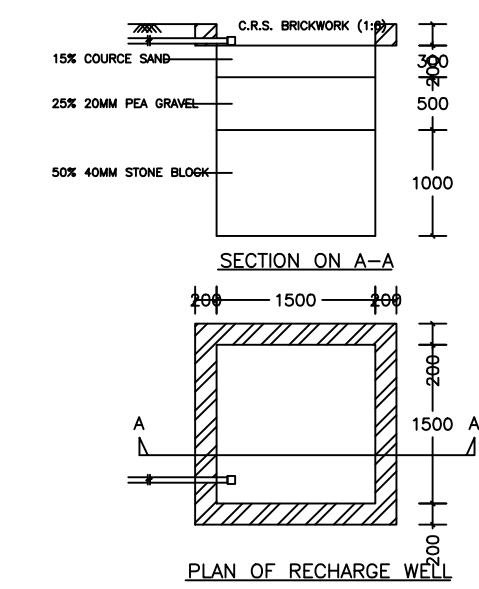

SECTION ON A-A

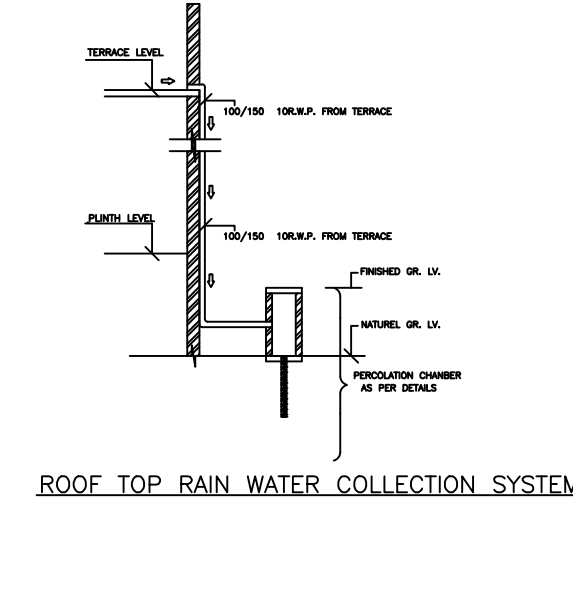

PLAN OF RECHARGE WELL

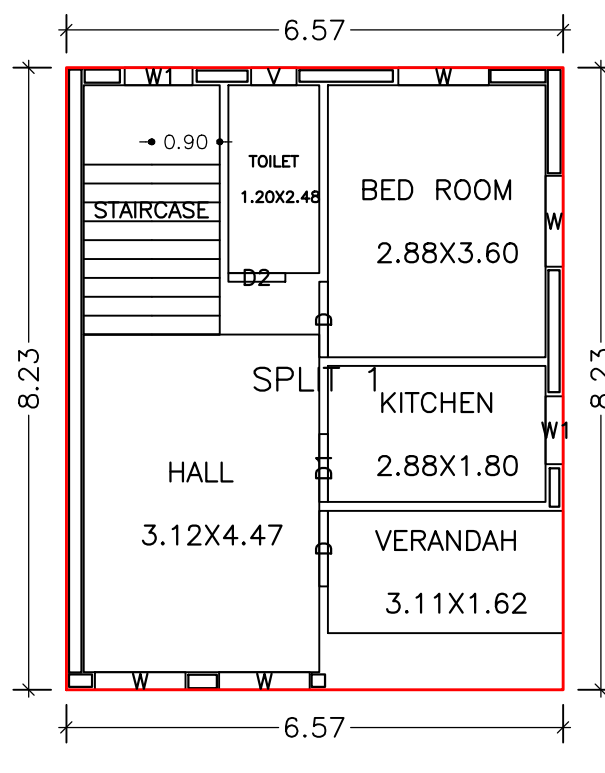

GROUND FLOOR PLAN (Proposed)
SCALE 1:100

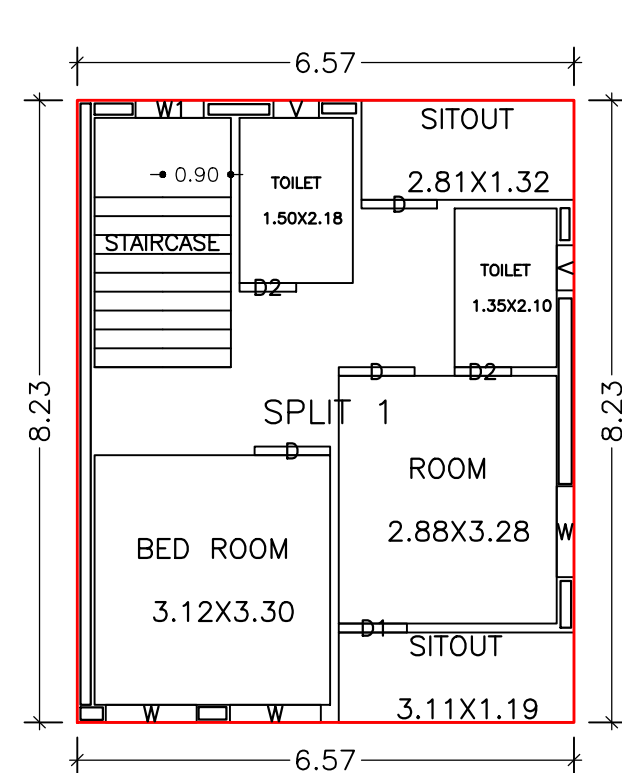

FIRST FLOOR PLAN (Proposed)
SCALE 1:100

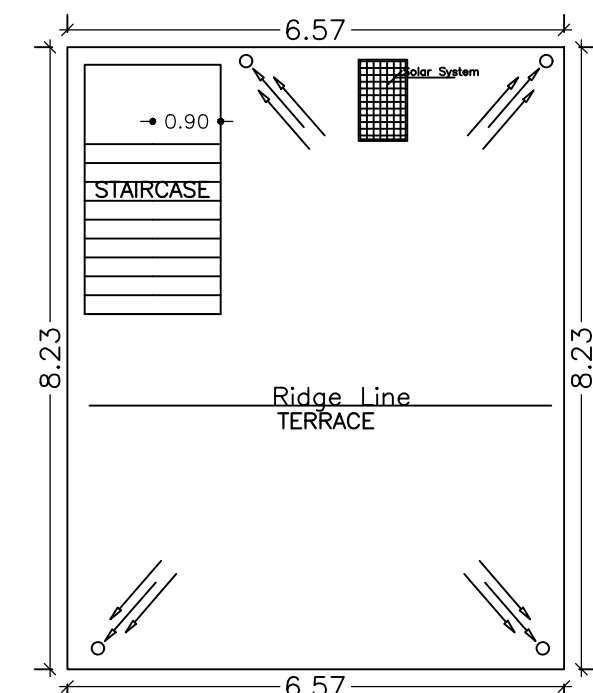

TERRACE FLOOR PLAN (Proposed)
SCALE 1:100

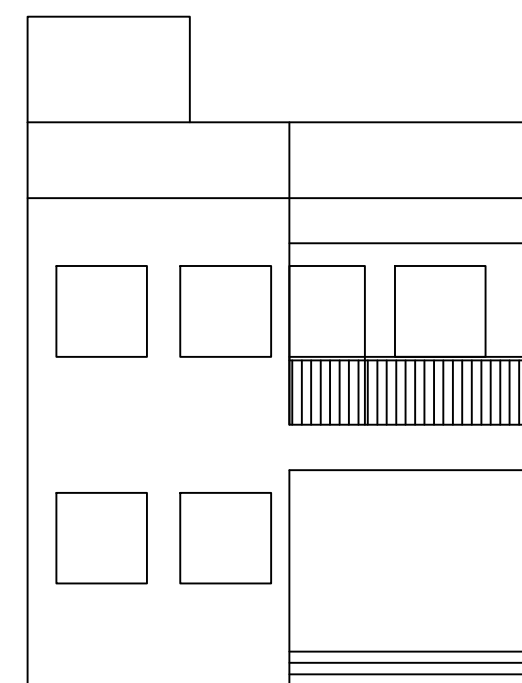

Front Elevation

SCHEDULE OF DOOR:

BUILDING NAME	NAME	LENGTH	HEIGHT	NOS
A (SHANKAR PRASAD SINGH AND OTHERS)	D2	0.75	2.10	03
A (SHANKAR PRASAD SINGH AND OTHERS)	D1	0.90	2.10	02
A (SHANKAR PRASAD SINGH AND OTHERS)	D	1.00	2.10	05

SCHEDULE OF WINDOW/VENTILATION:

BUILDING NAME	NAME	LENGTH	HEIGHT	NOS
A (SHANKAR PRASAD SINGH AND OTHERS)	V	0.60	0.60	03
A (SHANKAR PRASAD SINGH AND OTHERS)	W1	0.90	1.20	03
A (SHANKAR PRASAD SINGH AND OTHERS)	W	1.20	1.20	07

Building :A (SHANKAR PRASAD SINGH AND OTHERS)

Floor Name	Total Built Up Area (Sq.mt.)	Proposed FAR Area (Sq.mt.) Resi.	Total FAR Area (Sq.mt.)	Total Consumed Additional FAR Area (Sq.mt.)	Tnmt (No.)
Ground Floor	54.05	54.05	54.05	54.05	01
First Floor	54.05	54.05	54.05	54.05	00
Terrace Floor	0.00	0.00	0.00	0.00	00
Total :	108.10	108.10	108.10	108.10	01
Total Number of Same Buildings :	1				
Total :	108.10	108.10	108.10	108.10	01

Building USE/SUBUSE Details

Building Name	Building Use	Building SubUse	Building Structure
A (SHANKAR PRASAD SINGH AND OTHERS)	Residential	Bungalow/ Dwelling / Non Apartment	Non-Highrise

LTP NAME AND SIGNATURE PIYUSH KANTI SINGH DMC/ENG/0020/2016	STRUCTURAL ENG'S NAME AND SIGNATURE	BUILDER NAME AND SIGNATURE	OWNER'S NAME AND SIGNATURE
---	-------------------------------------	----------------------------	----------------------------