

FAR & Tenement Details (Table 4c-1)

Building	No. of Same Bldg	Total Built Up Area (Sq.mt.)	Proposed FAR Area (Sq.mt.) Resi.	Total FAR Area (Sq.mt.)	Total Consumed Additional FAR Area (Sq.mt.)	Tnmt (No.)
A (A)	1	162.08	162.08	162.08	162.08	01
Grand Total:	1	162.08	162.08	162.08	162.08	01

Proposal Basic Information

Proposal File No.	DMC/BP/0125/W26/2020
Owner Name	BABITA DEVI
Khata No	80
Plot No	2713
Village Name	Hirapur
Use	Residential
SubUse	Bungalow/ Dwelling / Non Apartment

AREA STATEMENT		VERSION NO. : 1.0.46
DHANBAD MUNICIPAL CORPORATION		VERSION DATE: 22/06/2020
PROJECT DETAIL:		
Region: JHARKHAND URBAN LOCAL BODIES	Plot Use: Residential	
District: DHANBAD	Plot SubUse: Bungalow/ Dwelling / Non Apartment	
Authority: DHANBAD MUNICIPAL CORPORATION	PlotNearbyReligiousStructure: NA	
Inward No: DMC/BP/0125/W26/2020	PlotSubPlot No: 2713	
Application Type: General Proposal	North: Plot No. - 2716	
Project Type: Building Permission	South: Road Width - 4.54	
Nature of Development: New	East: Plot No. - CAHAR DWARI	
Location of Development Area: Old Area	West: Plot No. - 2715	
AREA DETAILS:		
AREA OF PLOT (Minimum)	(A)	SQ.MT. 133.03
NET AREA OF PLOT(Gross Plot Area - Deduction from Gross Plot area)	(A-Deductions)	133.03
Deduction for Balance Plot Area(from Gross Plot Area)		
Common Plot		18.76
Total		18.76
BALANCE AREA OF PLOT(Net Plot Area - Recreational/Amenity space)	(A-Deductions)	114.27
PLOT AREA FOR COVERAGE(Net Plot Area)	(A-Deductions)	133.03
Plot Area for FAR (Net Plot Area + RoadWidening Area)	(A-Deductions)	133.03
COVERAGE CHECK		
Permissible Coverage area ( 70.00 % )		93.12
Proposed Coverage Area ( 60.92 % )		81.04
Total Prop. Coverage Area ( 60.92 % )		81.04
Balance coverage area ( 9.08 % )		12.08
FAR CHECK		
Perm. FAR Area ( 1.50 )		199.54
Total Perm. FAR area		199.54
Residential FAR		162.08
Proposed FAR Area		162.08
Total Proposed FAR Area		162.08
Consumed FAR (Factor)		1.22
Balance FAR Area		37.46
BUILT UP AREA CHECK		
Total Proposed BuiltUp Area		162.08
ARCHITECT (Regd)	MANOJ KUMAR SINGH	
ENGINEER (Regd)		
SUPERVISOR (Regd)		
OWNER (Regd)	BABITA DEVI	
DEVELOPMENT AUTHORITY LOCAL BODY		

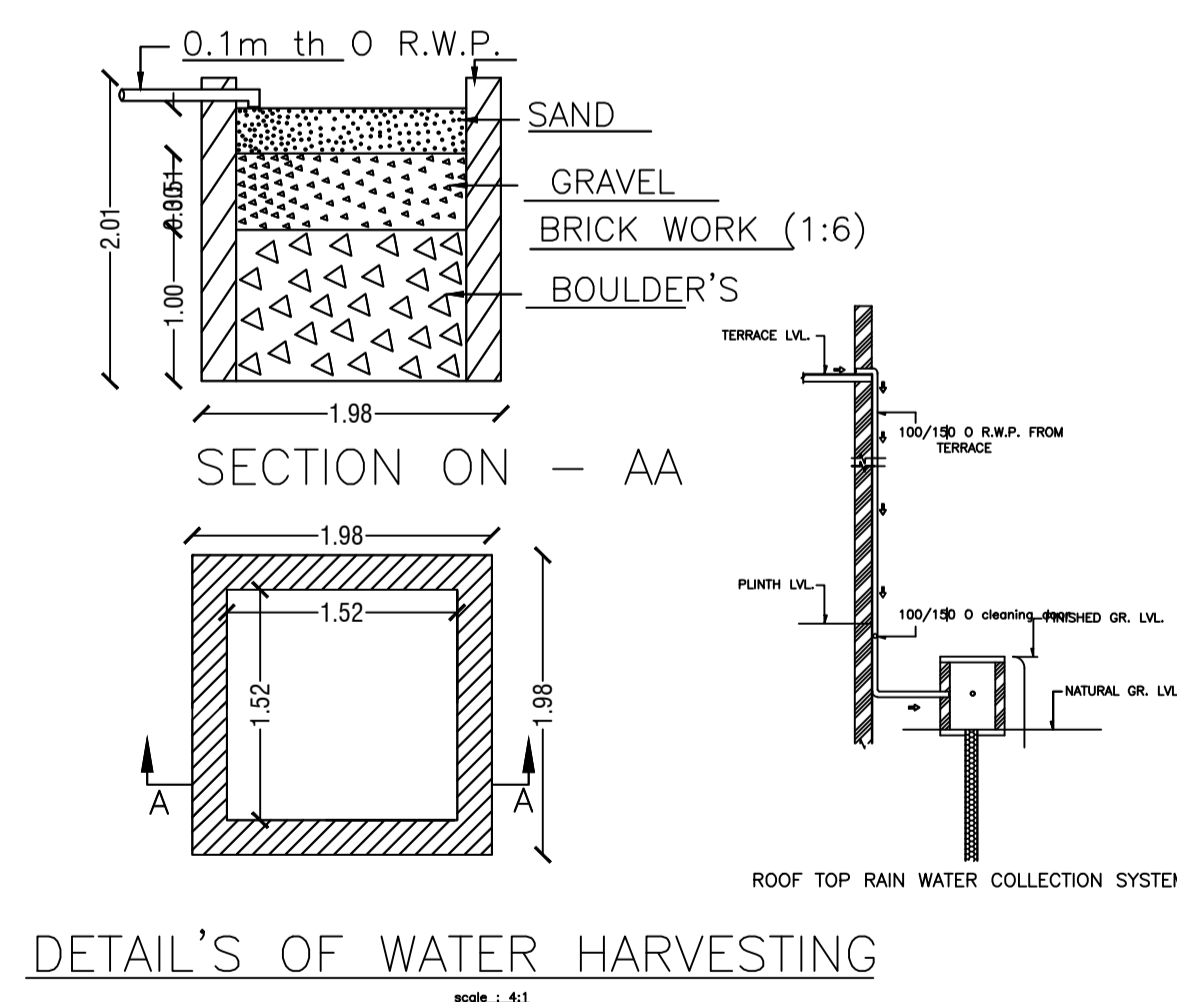
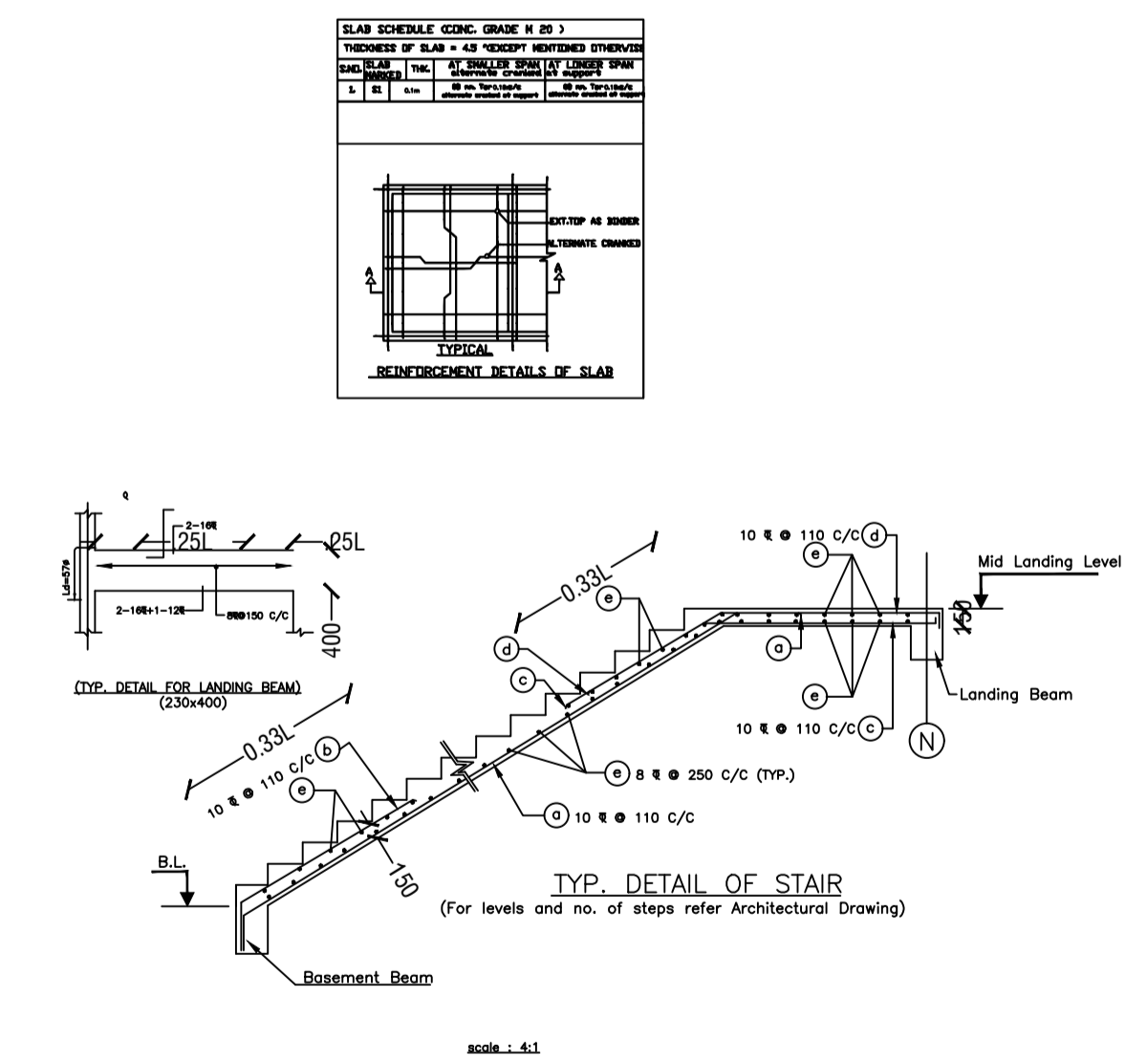
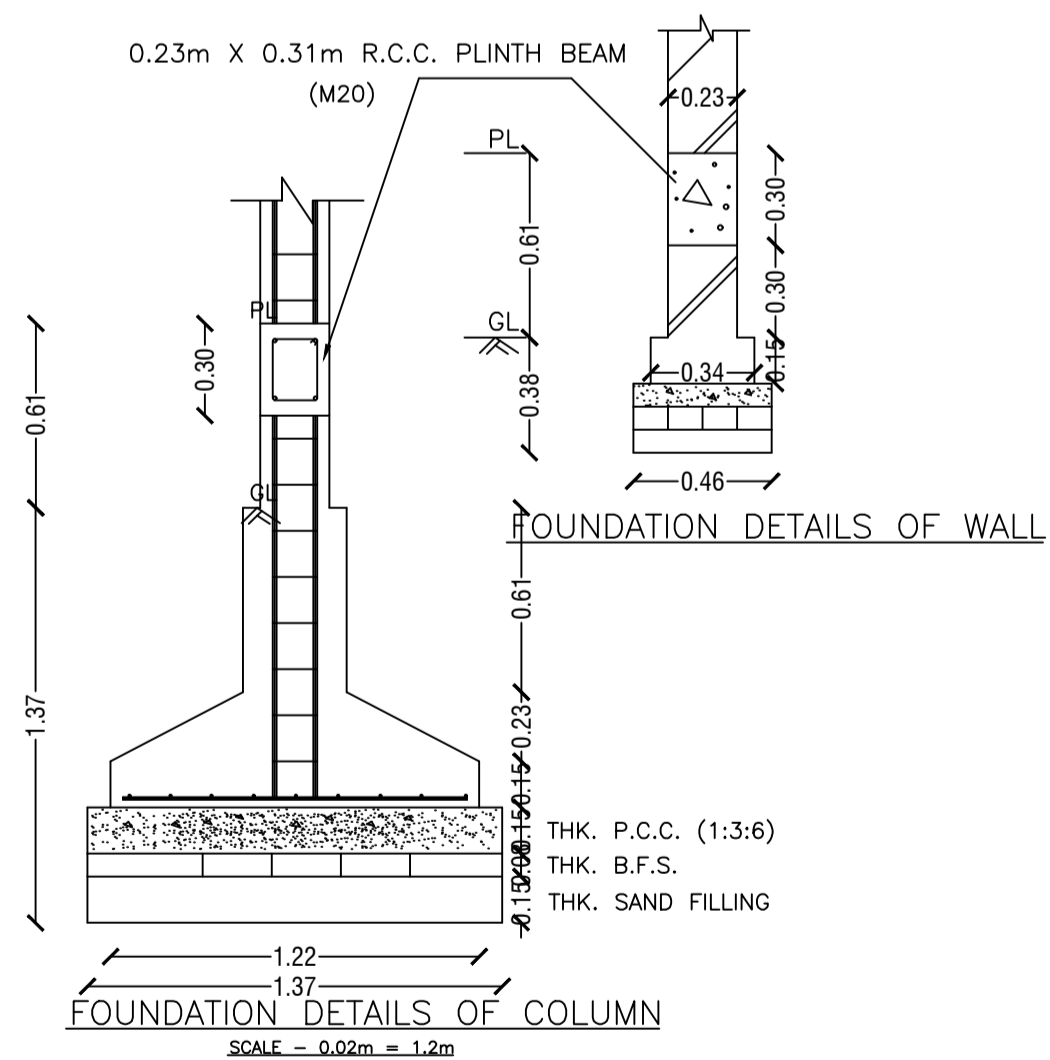
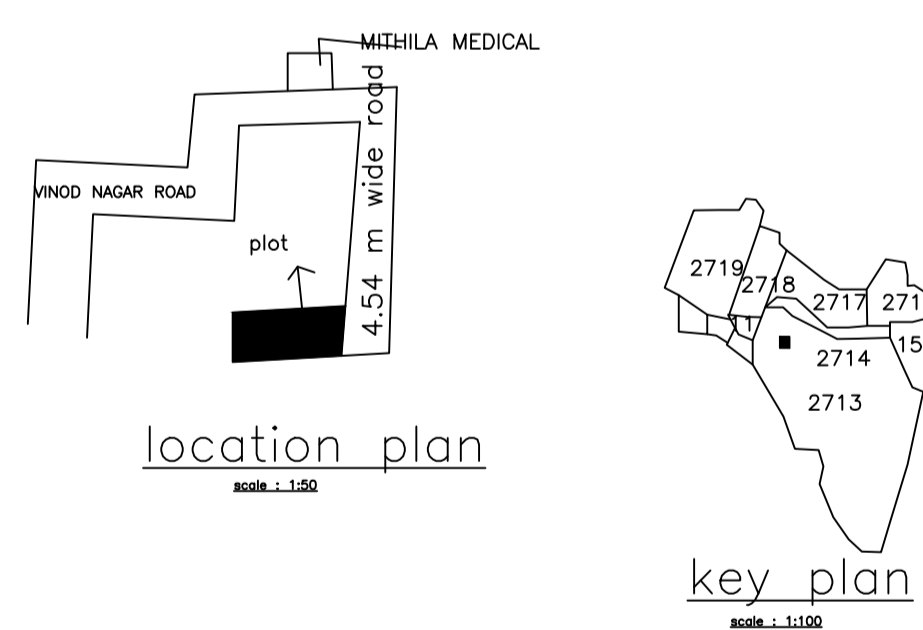
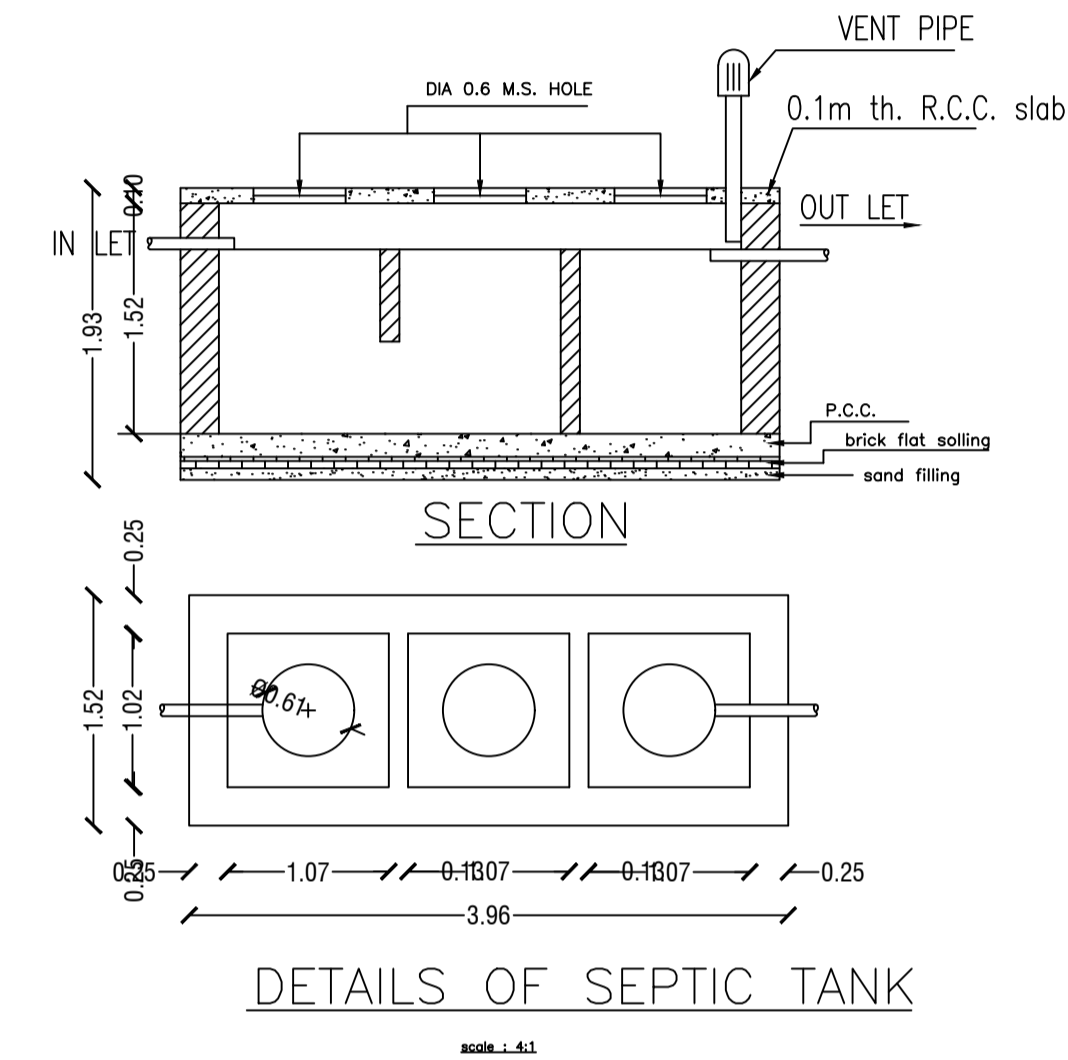

COLOR INDEX

PLOT BOUNDARY	Black
ABUTTING ROAD	Green
PROPOSED CONSTRUCTION	Red
COMMON PLOT	Yellow
ROAD WIDENING AREA	Orange
EXISTING (To be retained)	Blue
EXISTING (To be demolished)	Light Blue

Buildingwise Floor FAR Details

Floor Name	Building Name A (A)		Total	
	Proposed Built Up Area (Sq.mt.)	Proposed FAR Area (Sq.mt.)	Total Proposed Built Up Area (Sq.mt.)	Total FAR Area (Sq.mt.)
Ground Floor	81.04	81.04	81.04	81.04
First Floor	81.04	81.04	81.04	81.04
Terrace Floor	0.00	0.00	0.00	0.00
Total:	162.08	162.08	162.08	162.08

Building USE/SUBUSE Details

Building Name	Building Use	Building SubUse	Building Structure
A (A)	Residential	Residential Bldg/Apartment	Non-Highrise

Building :A (A)

Floor Name	Total Built Up Area (Sq.mt.)	Proposed FAR Area (Sq.mt.) Resi.	Total FAR Area (Sq.mt.)	Total Consumed Additional FAR Area (Sq.mt.)	Tnmt (No.)
Ground Floor	81.04	81.04	81.04	81.04	01
First Floor	81.04	81.04	81.04	81.04	00
Terrace Floor	0.00	0.00	0.00	0.00	00
Total:	162.08	162.08	162.08	162.08	01
Total Number of Same Buildings	1				
Total:	162.08	162.08	162.08	162.08	01

SCHEDULE OF DOOR:

BUILDING NAME	NAME	LENGTH	HEIGHT	NOS
A (A)	D	0.90	2.10	08

SCHEDULE OF WINDOW/VENTILATION:

BUILDING NAME	NAME	LENGTH	HEIGHT	NOS
A (A)	W	1.80	1.20	18

UnitBUA Table for Building :A (A)

FLOOR	Name	UnitBUA Type	UnitBUA Area	Carpet Area	No. of Rooms	No. of Tenement
GROUND FLOOR PLAN	SPLIT 1	FLAT	162.08	162.05	5	1
FIRST FLOOR PLAN	SPLIT 1	FLAT	0.00	0.00	5	0
Total:	-	-	162.08	162.05	10	1

LTP NAME AND SIGNATURE	STRUCTURAL ENG'S NAME AND SIGNATURE	BUILDER NAME AND SIGNATURE	DIGITAL SIGNATURE
MANOJ KUMAR SINGH DMC/DFTM/0026/2017			

Proposal Basic Information

Proposal File No.	DMC/BP/0125/W26/2020
Owner Name	BABITA DEVI
Khata No	80
Plot No	2713
Village Name	Hirapur
Use	Residential
SubUse	Bungalow/ Dwelling / Non Apartment

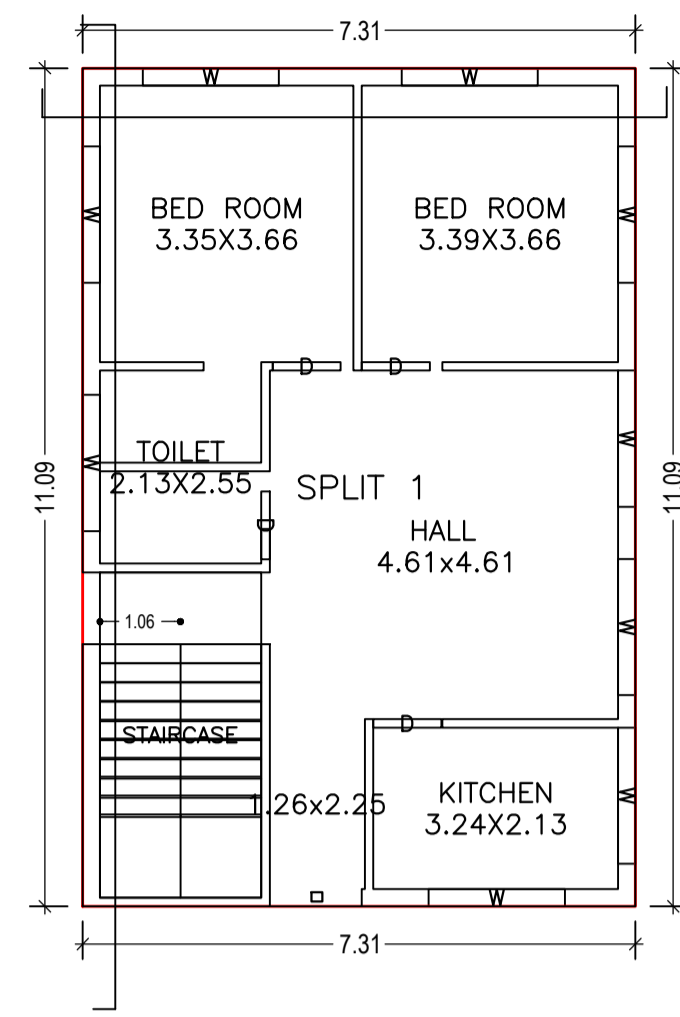

GROUND FLOOR PLAN (Proposed) (SCALE 1:100)

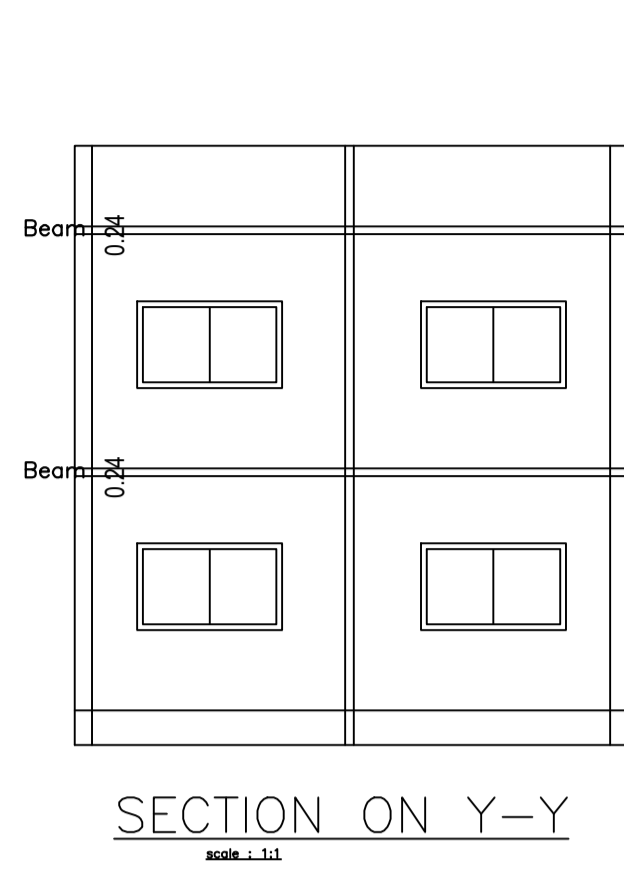

SECTION ON Y-Y

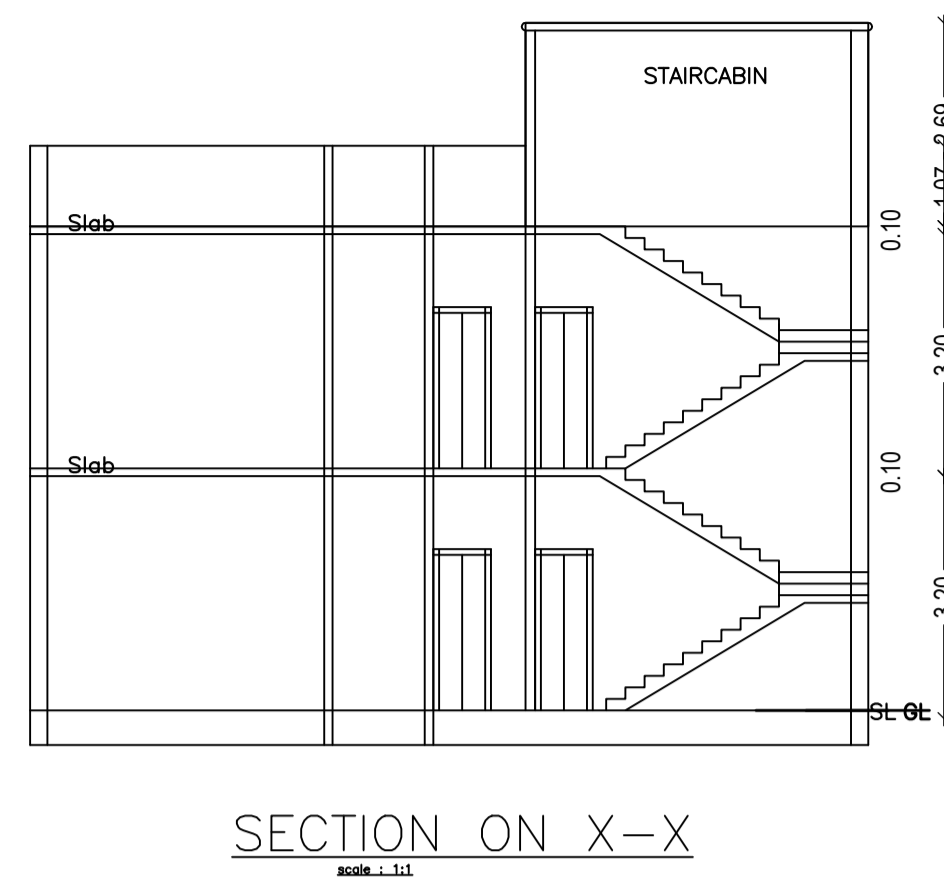

SECTION ON X-X

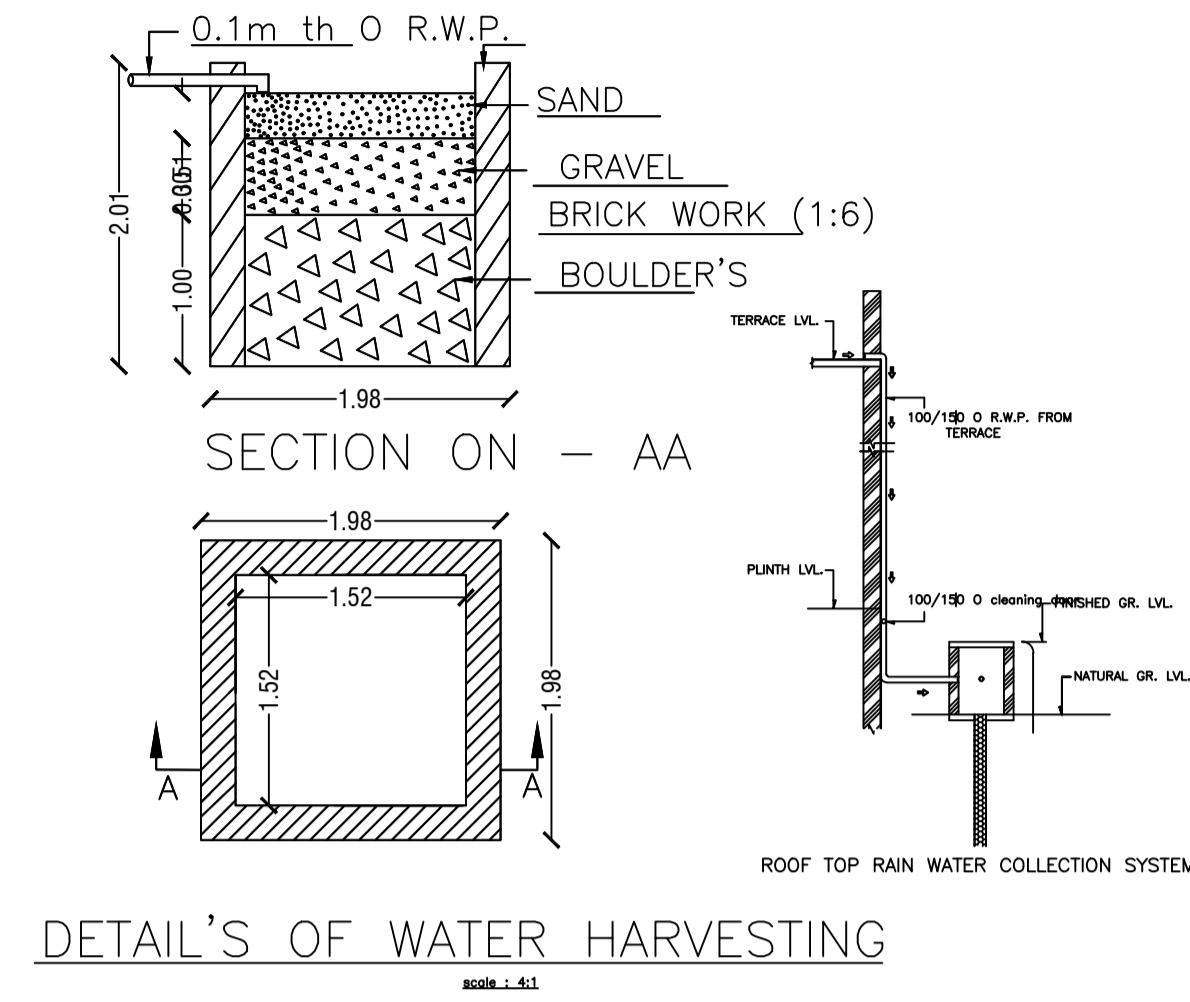

DETAIL'S OF WATER HARVESTING

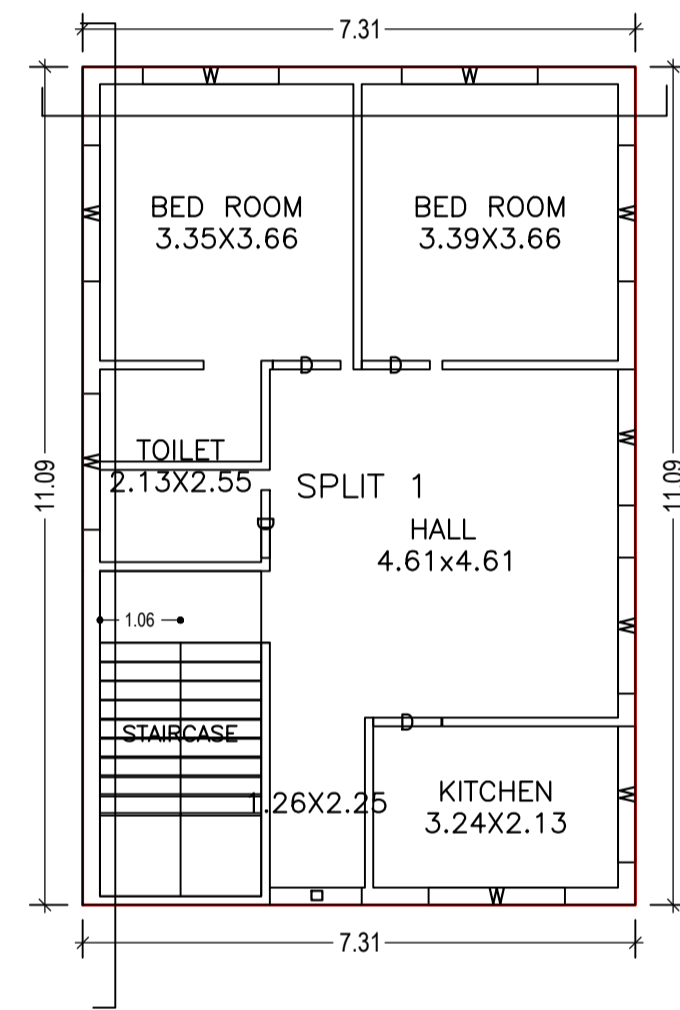

FIRST FLOOR PLAN (Proposed) (SCALE 1:100)

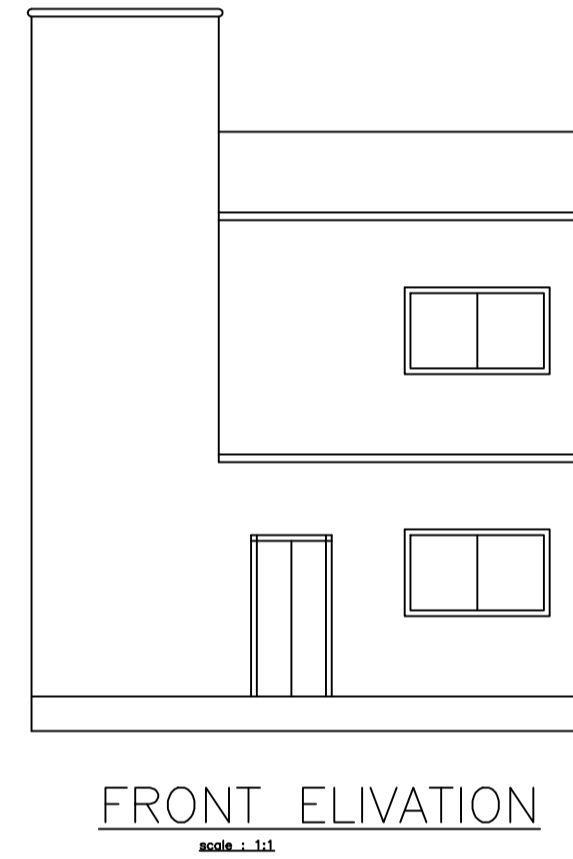

FRONT ELIVATION

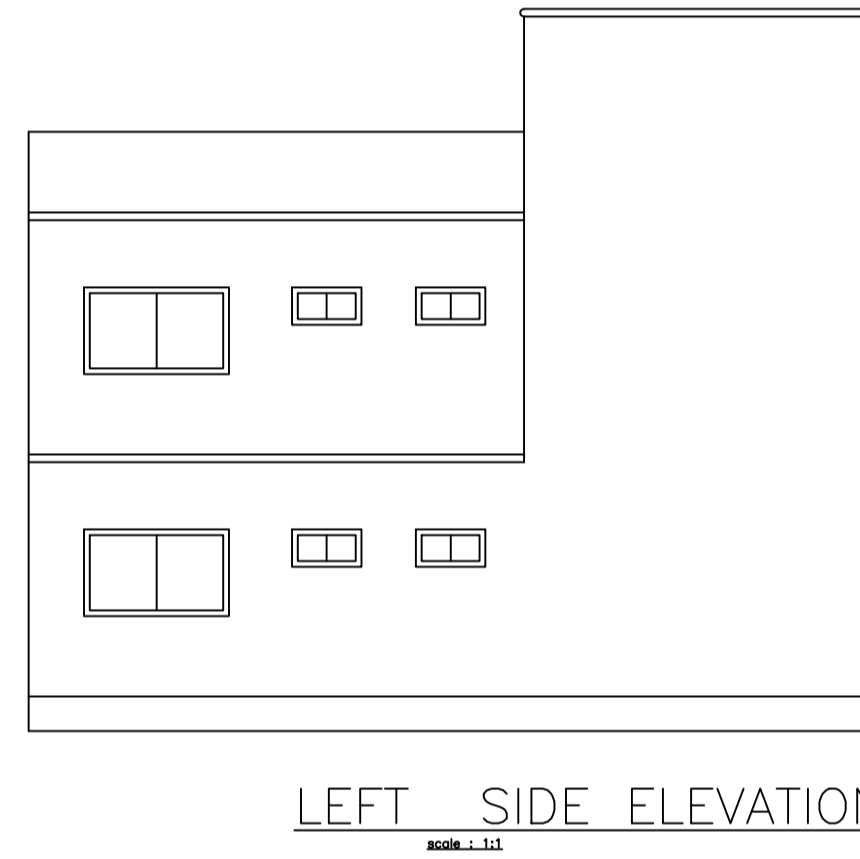

LEFT SIDE ELEVATION

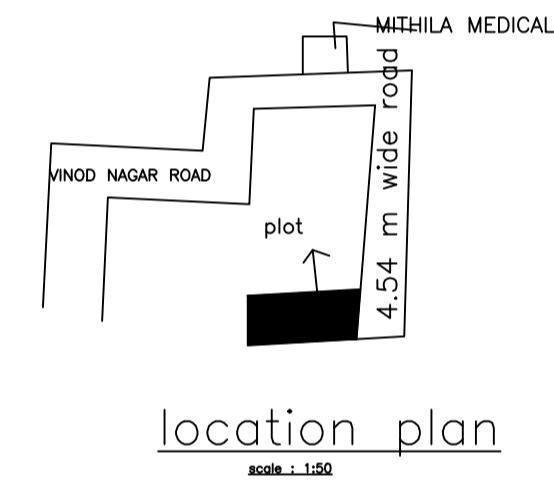

location plan



key plan

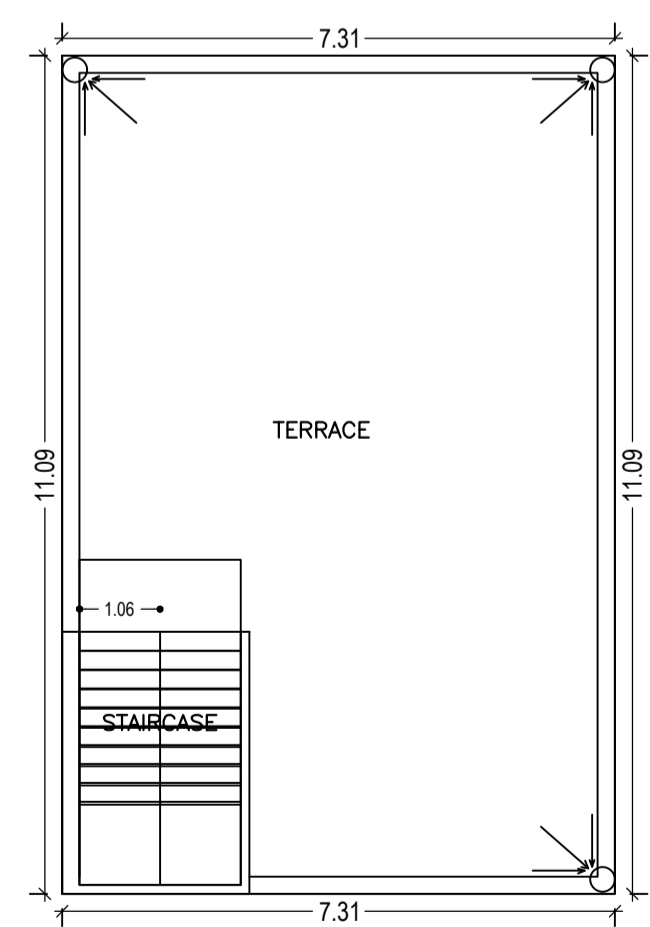

TERRACE FLOOR PLAN (SCALE 1:100)

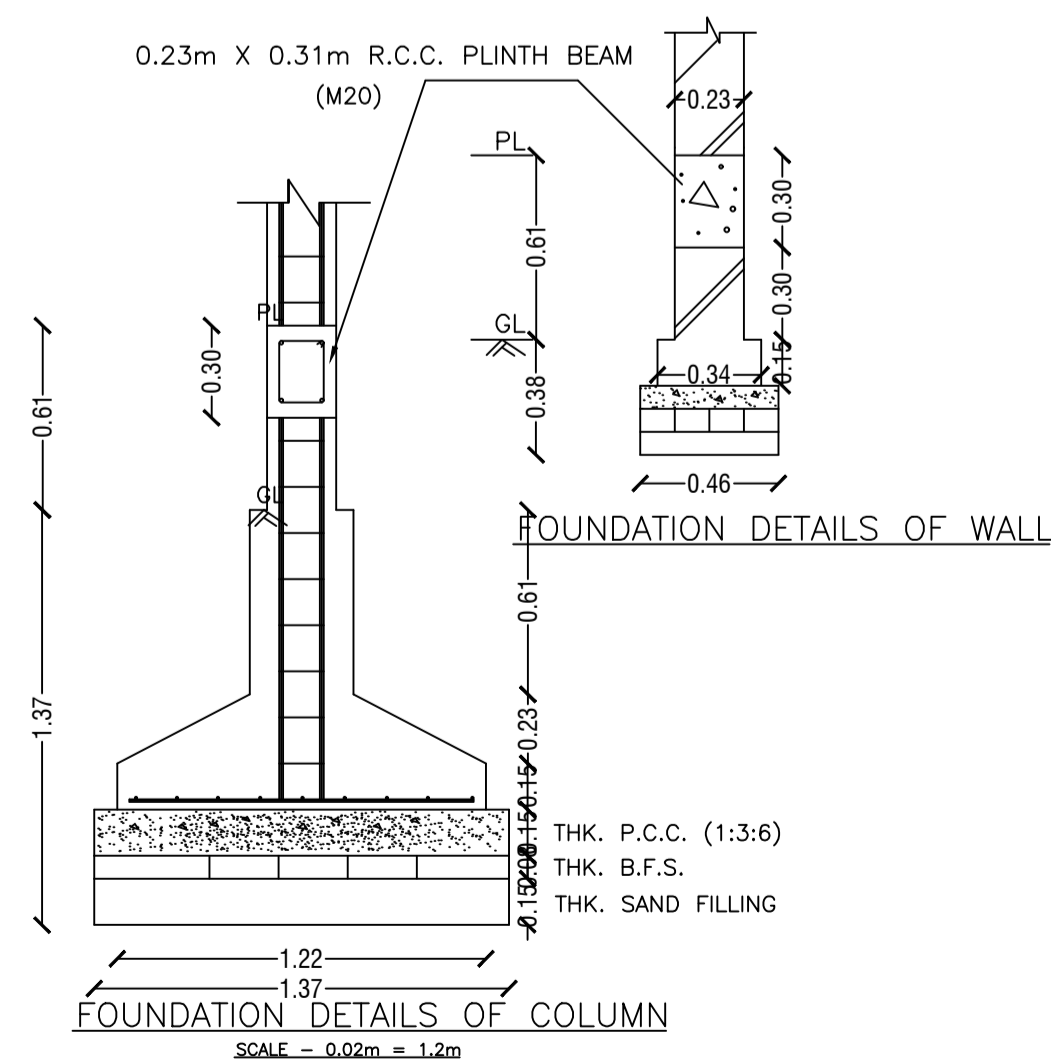

FOUNDATION DETAILS OF COLUMN

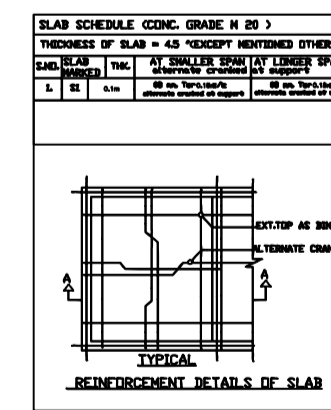

TYPICAL REINFORCEMENT DETAILS OF SLAB

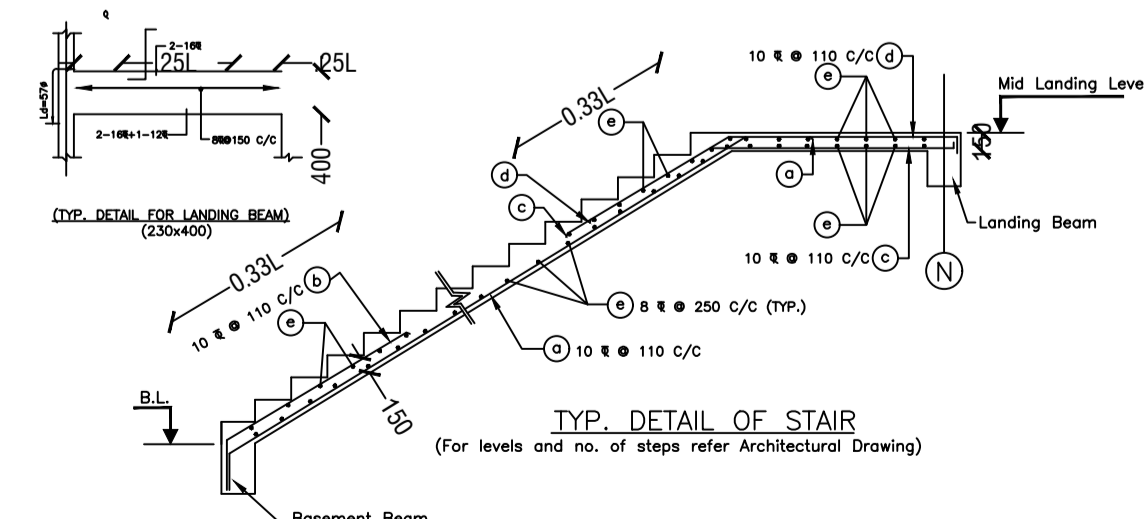

TYP. DETAIL OF STAIR

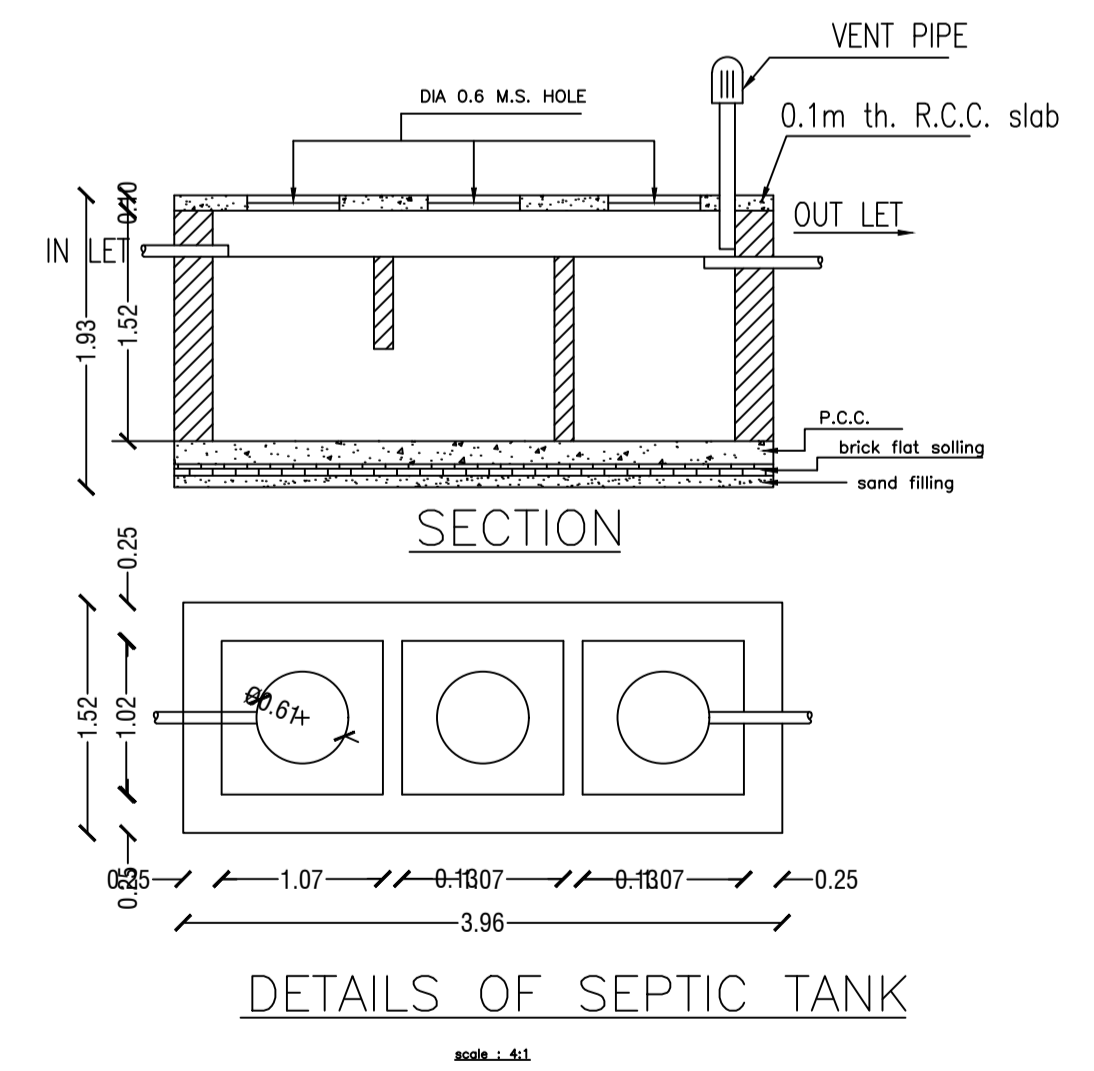

DETAILS OF SEPTIC TANK

LTP NAME AND SIGNATURE	STRUCTURAL ENG'S NAME AND SIGNATURE	BUILDER NAME AND SIGNATURE	DIGITAL SIGNATURE
MANOJ KUMAR SINGH DMC/DFTMN/0026/2017			