

Proposal Basic Information

Proposal File No.	DMC/BP/0136/W23/2020
Owner Name	SRI JAI KANT JHA & SMT. K. MOHINI
Khata No	OLD 09 / NEW 599
Plot No	old 3228 / new 3925
Village Name	Kolakusma
Use	Residential
SubUse	Bungalow/ Dwelling / Non Apartment

COLOR INDEX

PLOT BOUNDARY	Black
ABUTTING ROAD	Green
PROPOSED CONSTRUCTION	Red
COMMON PLOT	Yellow
ROAD WIDENING AREA	Orange
EXISTING (To be retained)	Blue
EXISTING (To be demolished)	Light Blue

AREA STATEMENT	VERSION NO.: 1.0.47
DHANBAD MUNICIPAL CORPORATION	VERSION DATE: 22/06/2020
PROJECT DETAIL:	
Region: JHARKHAND URBAN LOCAL BODIES	Plot Use: Residential
District: DHANBAD	Plot SubUse: Bungalow/ Dwelling / Non Apartment
Authority: DHANBAD MUNICIPAL CORPORATION	PlotNearbyReligiousStructure: NA
Inward No: DMC/BP/0136/W23/2020	PlotSubPlot No: old 3228 / new 3925
Application Type: General Proposal	North: Plot No. - part of plot 3228
Project Type: Building Permission	South: Plot No. - part of plot 3229
Nature of Development: New	East: Road Width - 5.48
Location of Development Area: Old Area	West: Plot No. - 3230

AREA DETAILS:		SQ.MT.
AREA OF PLOT (Minimum)	(A)	265.38
NET AREA OF PLOT(Gross Plot Area - Deduction from Gross Plot area)	(A-Deductions)	265.38
Deduction for Balance Plot Area(from Gross Plot Area)		
Common Plot		13.85
Total		13.85
BALANCE AREA OF PLOT(Net Plot Area - Recreational/Amenity space)	(A-Deductions)	251.53
PLOT AREA FOR COVERAGE(Net Plot Area + Road/Widening Area)	(A-Deductions)	265.38
Plot Area for FAR (Net Plot Area + Road/Widening Area)	(A-Deductions)	265.38
COVERAGE CHECK		
Permissible Coverage area (60.00 %)		159.23
Proposed Coverage Area (39.04 %)		103.60
Total Prop. Coverage Area (39.04 %)		103.60
Balance coverage area (20.96 %)		55.63
FAR CHECK		
Perm. FAR Area (1.80)		477.68
Total Perm. FAR area		477.68
Residential FAR		268.57
Proposed FAR Area		268.57
Total Proposed FAR Area		268.57
Consumed FAR (Factor)		1.01
Balance FAR Area		209.11
BUILT UP AREA CHECK		
Total Proposed BuiltUp Area		268.56
ARCHITECT (Regd)	ASHOK KUMAR	
ENGINEER (Regd)		
SUPERVISOR (Regd)		
OWNER (Regd)	SRI JAI KANT JHA & SMT. K. MOHINI	
DEVELOPMENT AUTHORITY	LOCAL BODY	

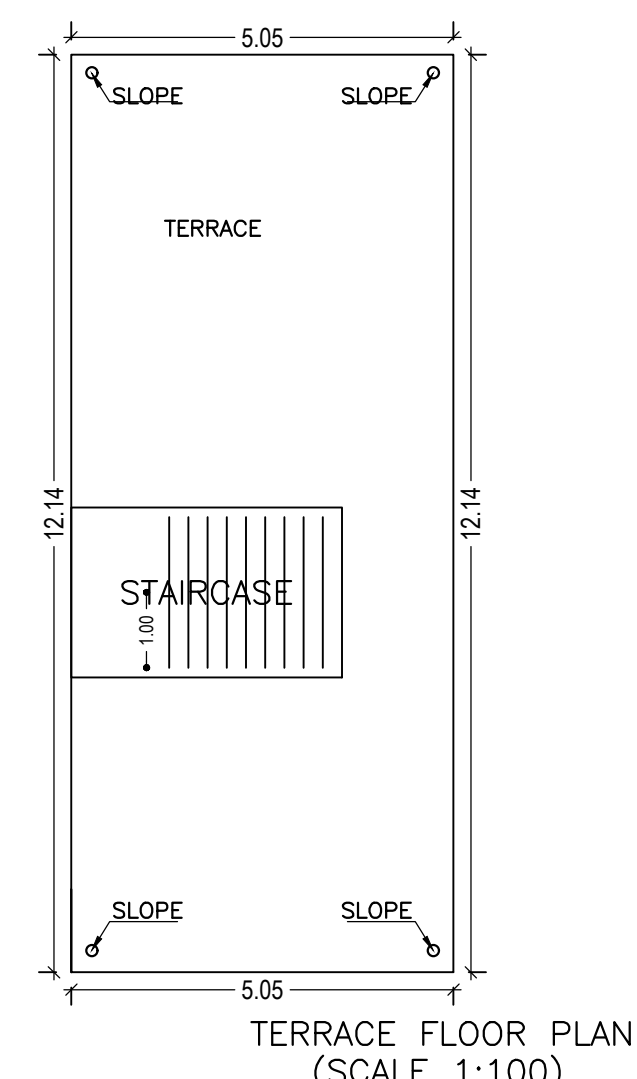
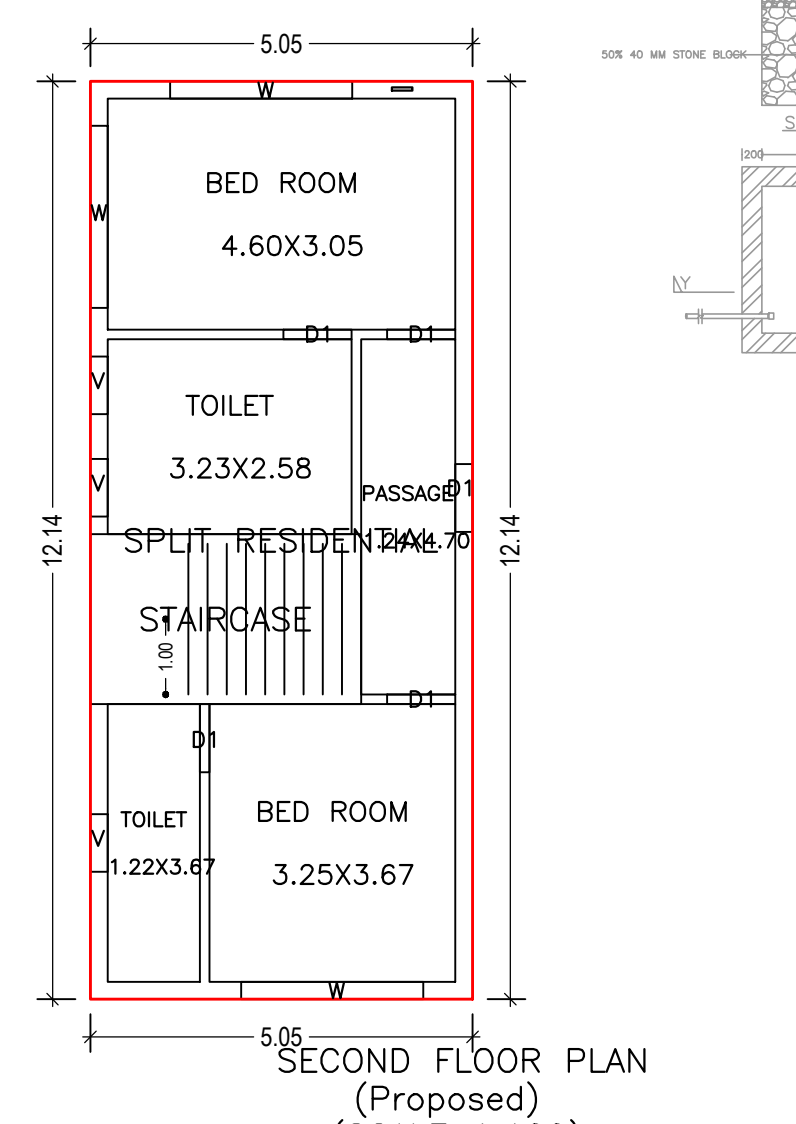
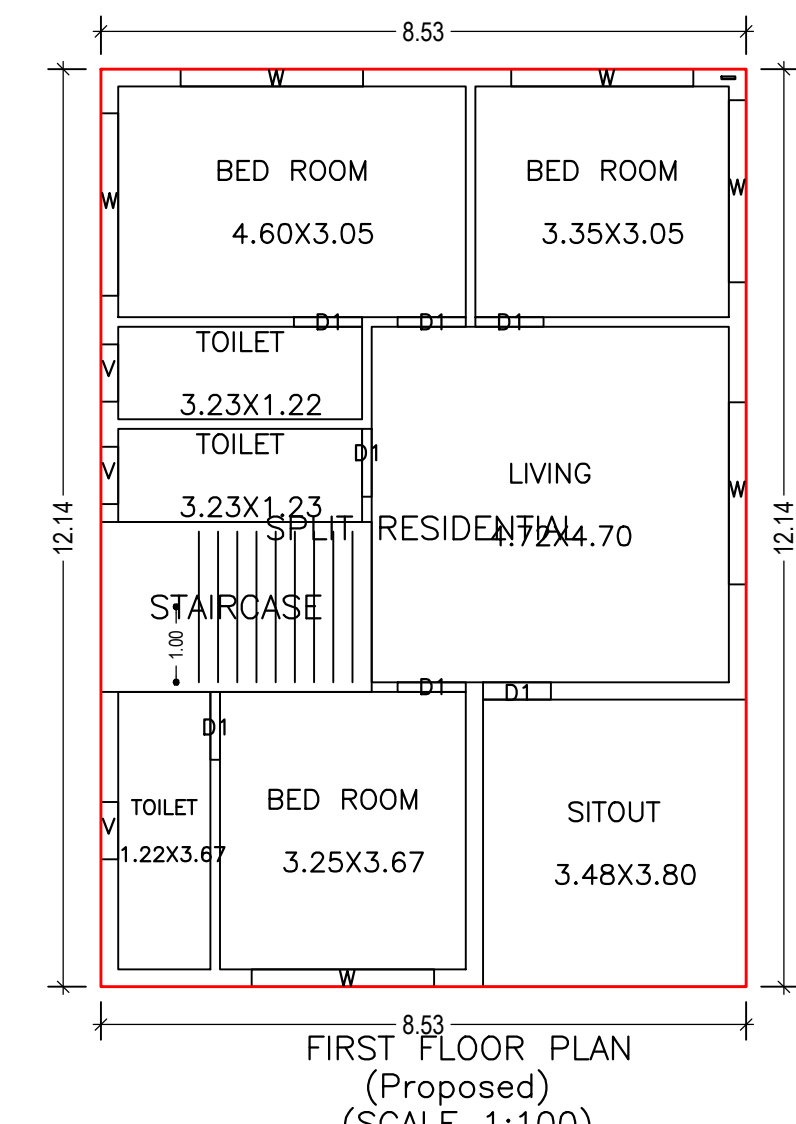
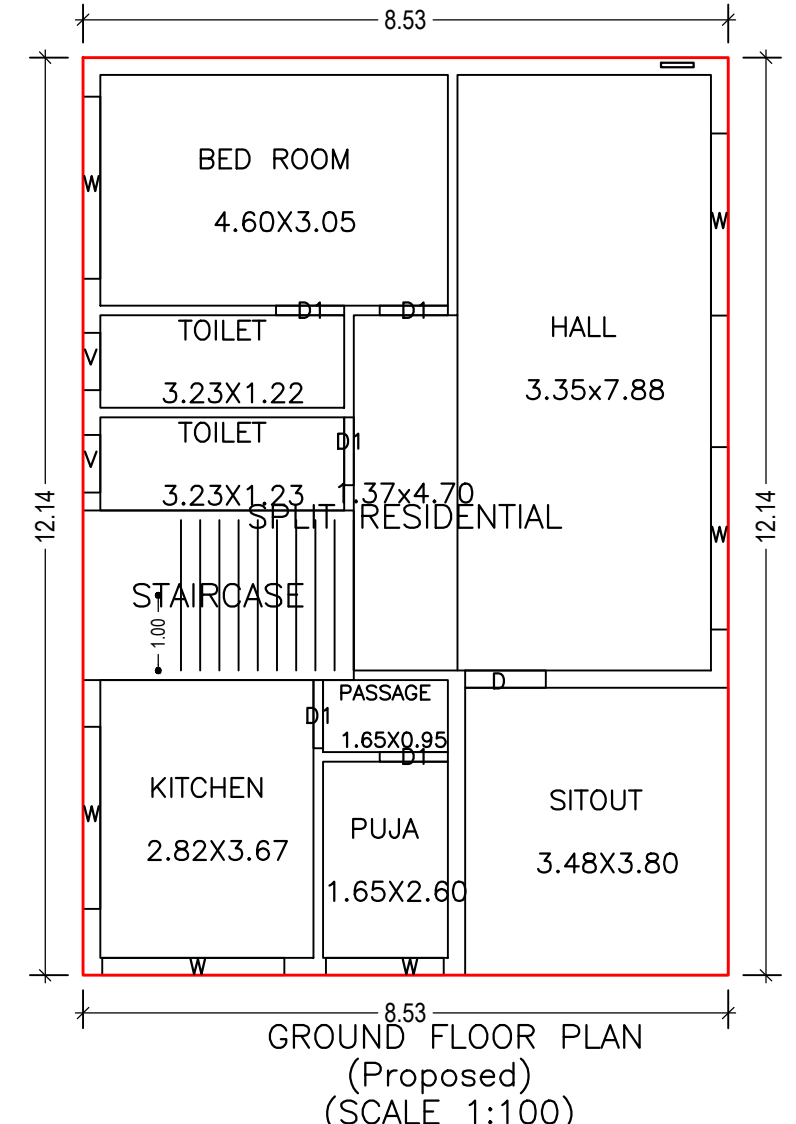
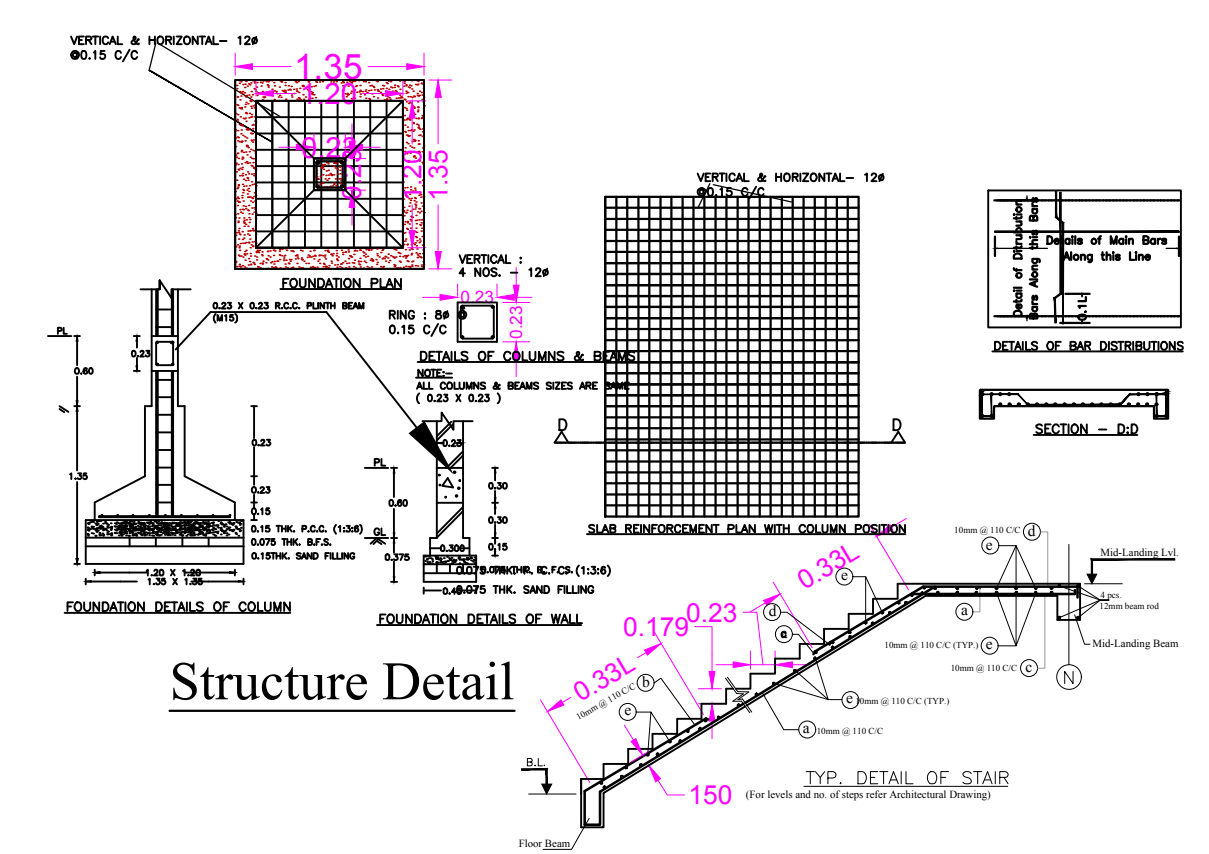
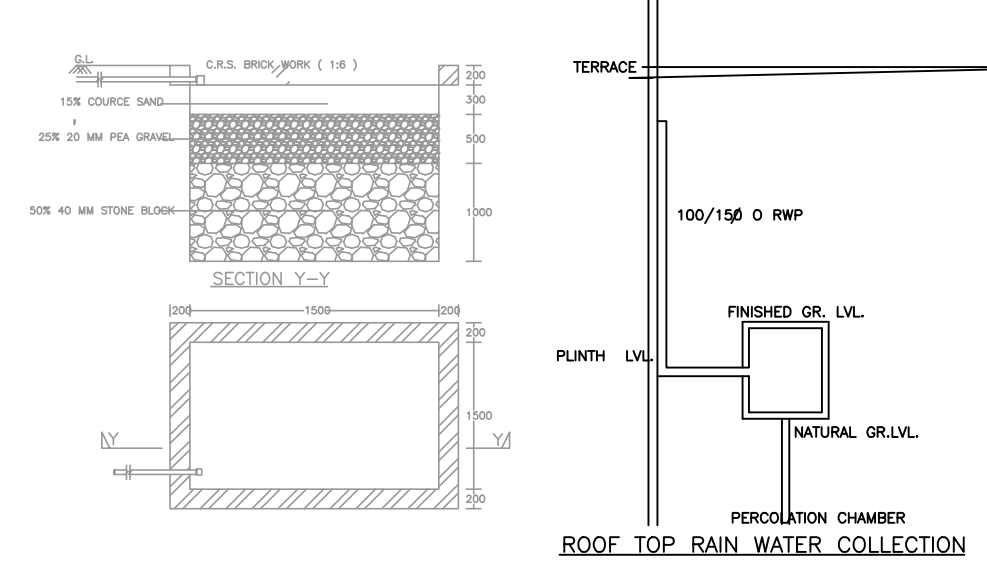
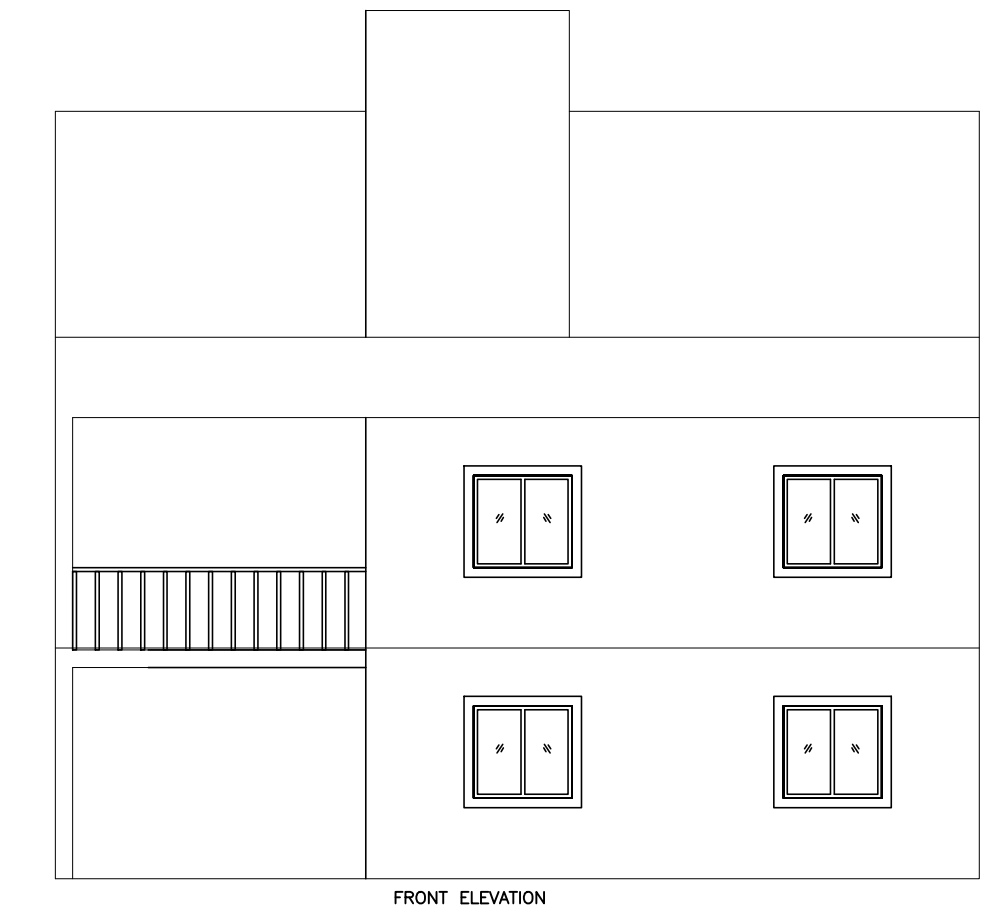
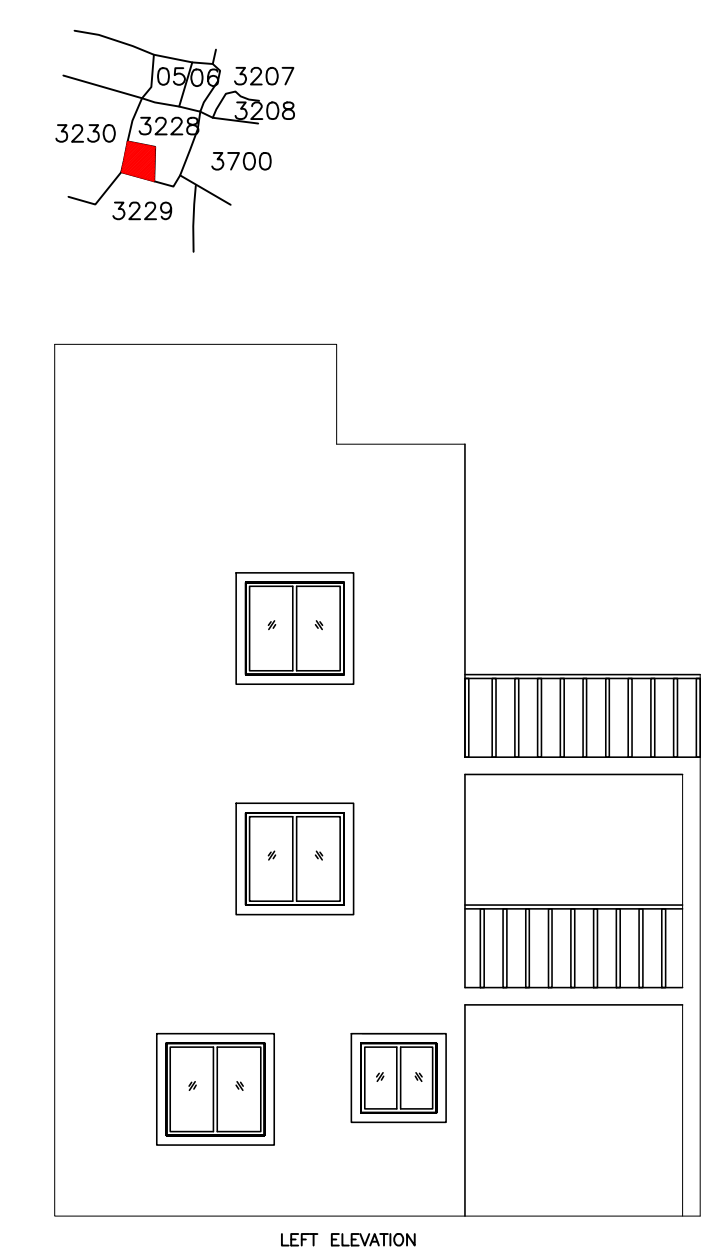
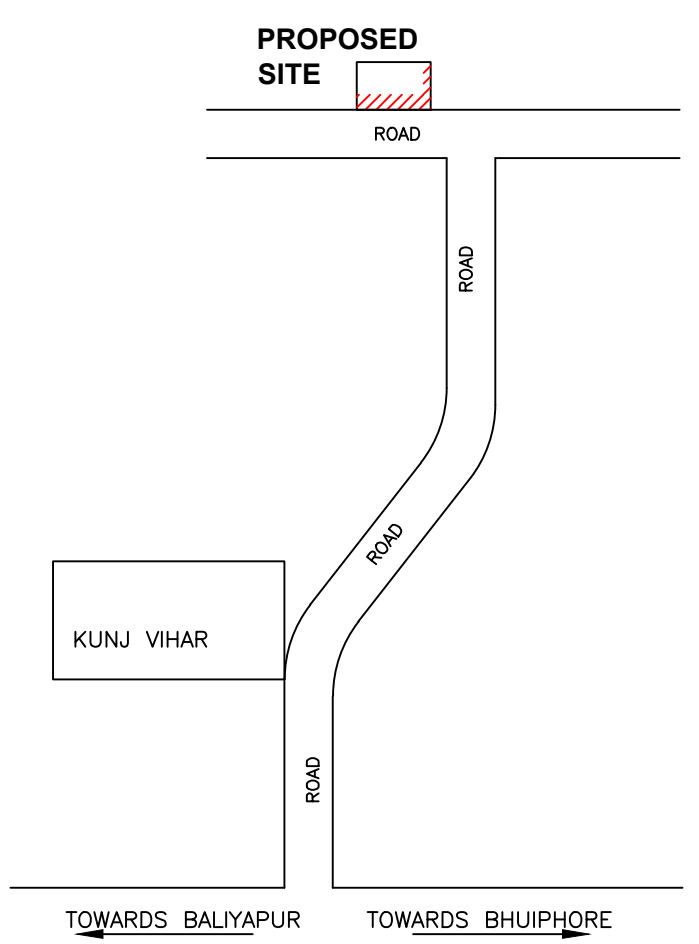
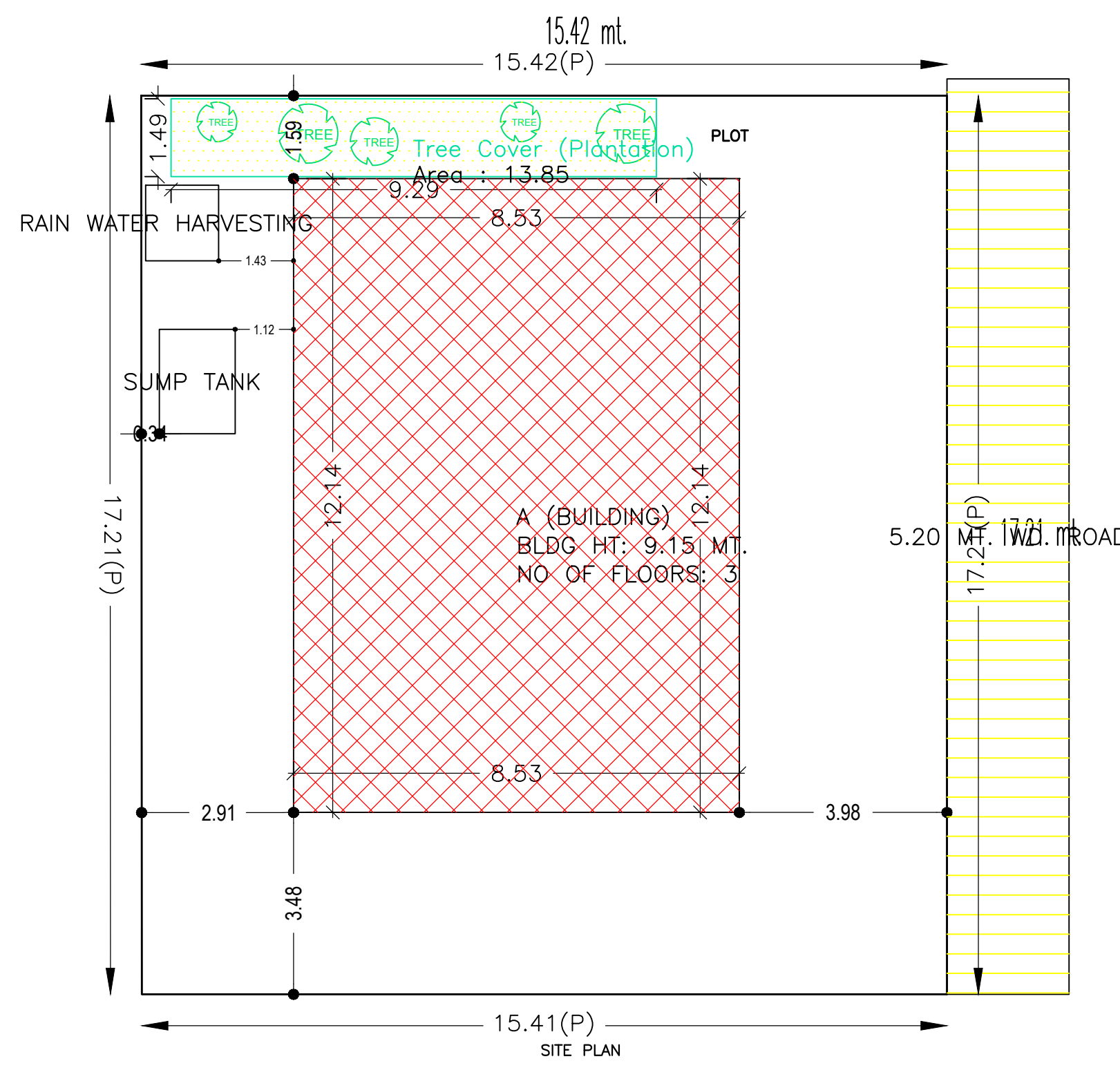

SCHEDULE OF DOOR:

BUILDING NAME	NAME	LENGTH	HEIGHT	NOS
A (BUILDING)	D1	0.90	2.10	17
A (BUILDING)	D	1.07	2.10	01

SCHEDULE OF WINDOW/VENTILATION:

BUILDING NAME	NAME	LENGTH	HEIGHT	NOS
A (BUILDING)	V	0.76	1.20	08
A (BUILDING)	W	1.56	1.20	01
A (BUILDING)	W	2.41	1.20	14

UnitBUA Table for Building :A (BUILDING)

FLOOR	Name	UnitBUA Type	UnitBUA Area	Carpet Area	No. of Rooms	No. of Tenement
GROUND FLOOR PLAN	SPLIT RESIDENTIAL	FLAT	268.57	268.53	8	1
FIRST FLOOR PLAN	SPLIT RESIDENTIAL	FLAT	0.00	0.00	8	0
SECOND FLOOR PLAN	SPLIT RESIDENTIAL	FLAT	0.00	0.00	5	0
Total:	-	-	268.57	268.53	21	1

Building :A (BUILDING)

Floor Name	Total Built Up Area (Sq.mt.)	Proposed FAR Area (Sq.mt.) Resi.	Total FAR Area (Sq.mt.)	Total Consumed Additional FAR Area (Sq.mt.)	Tnmt (No.)
Ground Floor	103.60	103.60	103.60	103.60	01
First Floor	103.60	103.60	103.60	103.60	00
Second Floor	61.36	61.36	61.36	61.36	00
Terrace Floor	0.00	0.00	0.00	0.00	00
Total:	268.56	268.56	268.56	268.56	01
Total Number of Same Buildings	1				
Total:	268.56	268.56	268.56	268.56	01

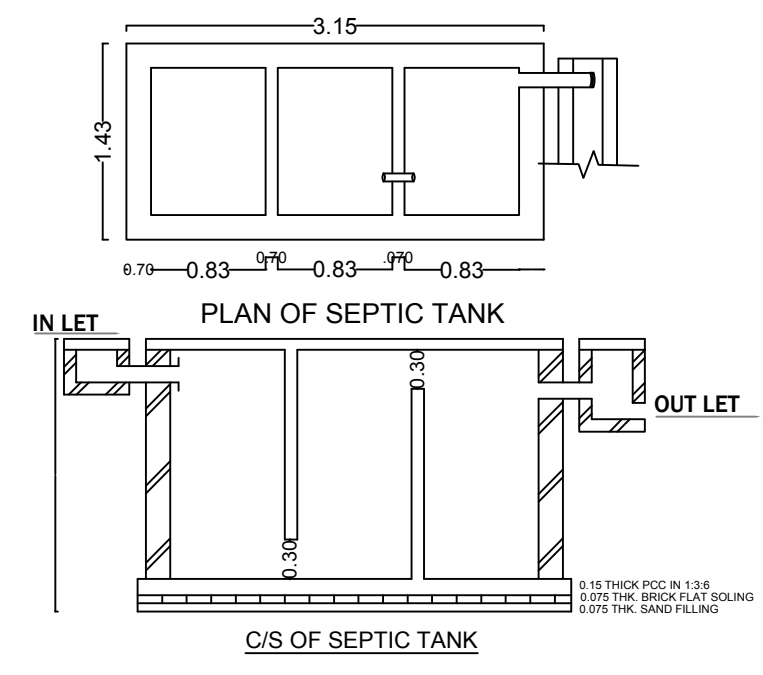
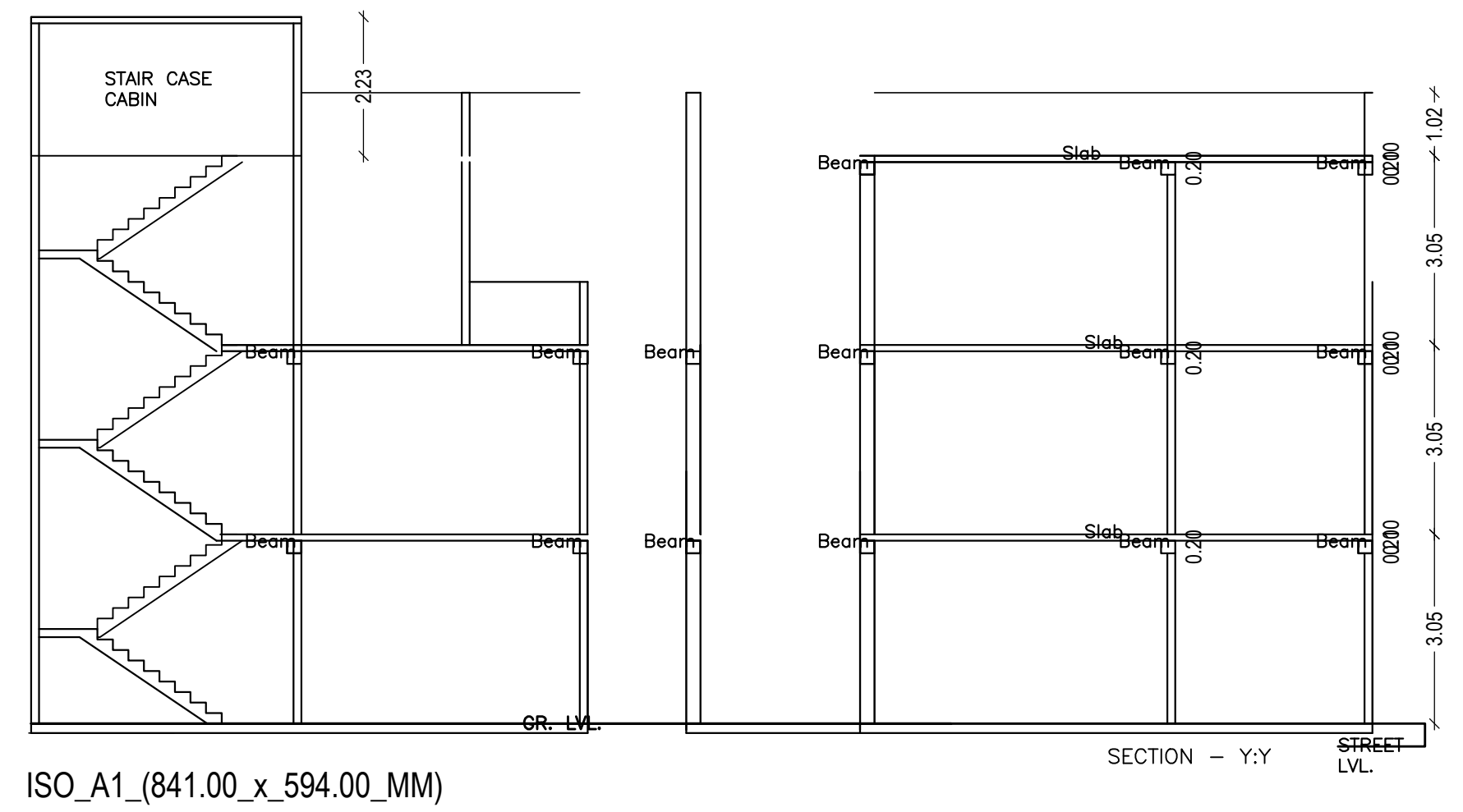

Buildingwise Floor FAR Details

Floor Name	Building Name		Total	
	Proposed Built Up Area (Sq.mt.)	Proposed FAR Area (Sq.mt.)	Total Proposed Built Up Area (Sq.mt.)	Total FAR Area (Sq.mt.)
Ground Floor	103.60	103.60	103.60	103.60
First Floor	103.60	103.60	103.60	103.60
Second Floor	61.36	61.36	61.36	61.36
Terrace Floor	0.00	0.00	0.00	0.00
Total:	268.56	268.56	268.56	268.56

Building USE/SUBUSE Details

Building Name	Building Use	Building SubUse	Building Structure
A (BUILDING)	Residential	Bungalow/ Dwelling / Non Apartment	Non-Highrise

FAR & Tenement Details (Table 4c-1)

Building	No. of Same Bldg	Total Built Up Area (Sq.mt.)	Proposed FAR Area (Sq.mt.) Resi.	Total FAR Area (Sq.mt.)	Total Consumed Additional FAR Area (Sq.mt.)	Tnmt (No.)
A (BUILDING)	1	268.56	268.56	268.56	268.56	01
Grand Total:	1	268.56	268.56	268.56	268.56	01

LTP NAME AND SIGNATURE	STRUCTURAL ENG'S NAME AND SIGNATURE	BUILDER NAME AND SIGNATURE	DIGITAL SIGNATURE
ASHOK KUMAR DMC/ENG/0011/2017			