

KEY PLAN

LOCATION

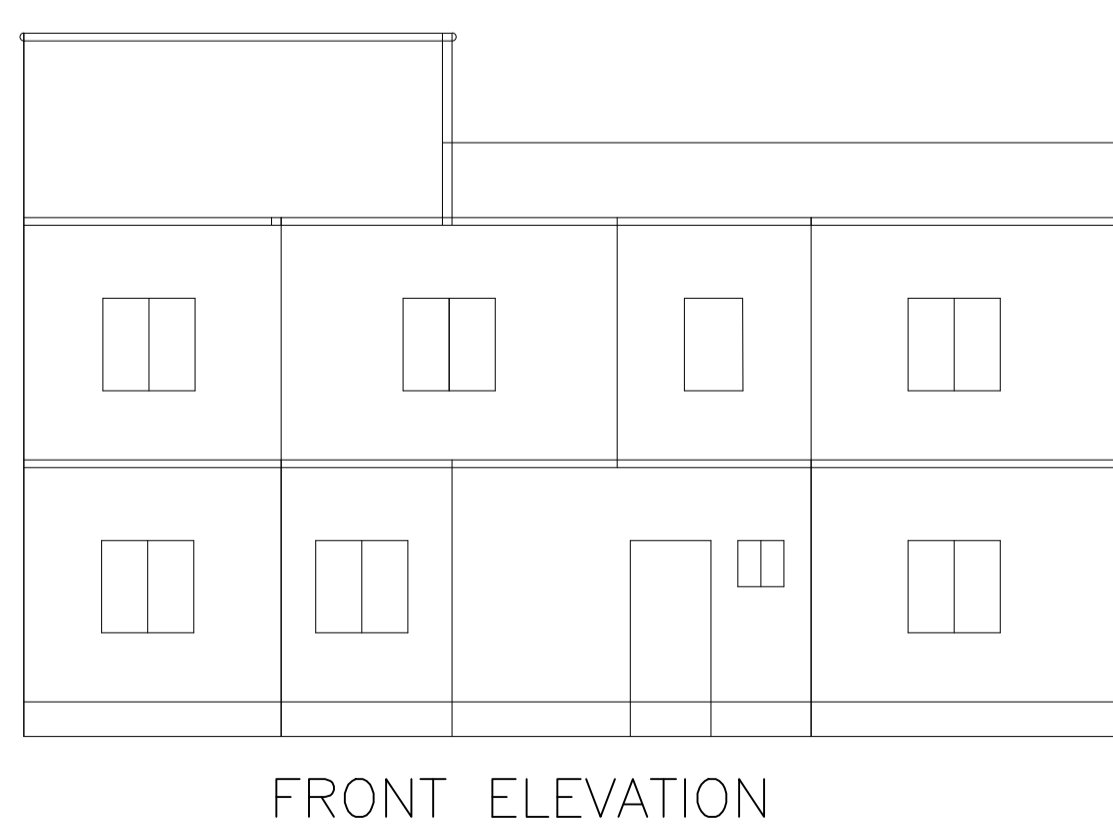
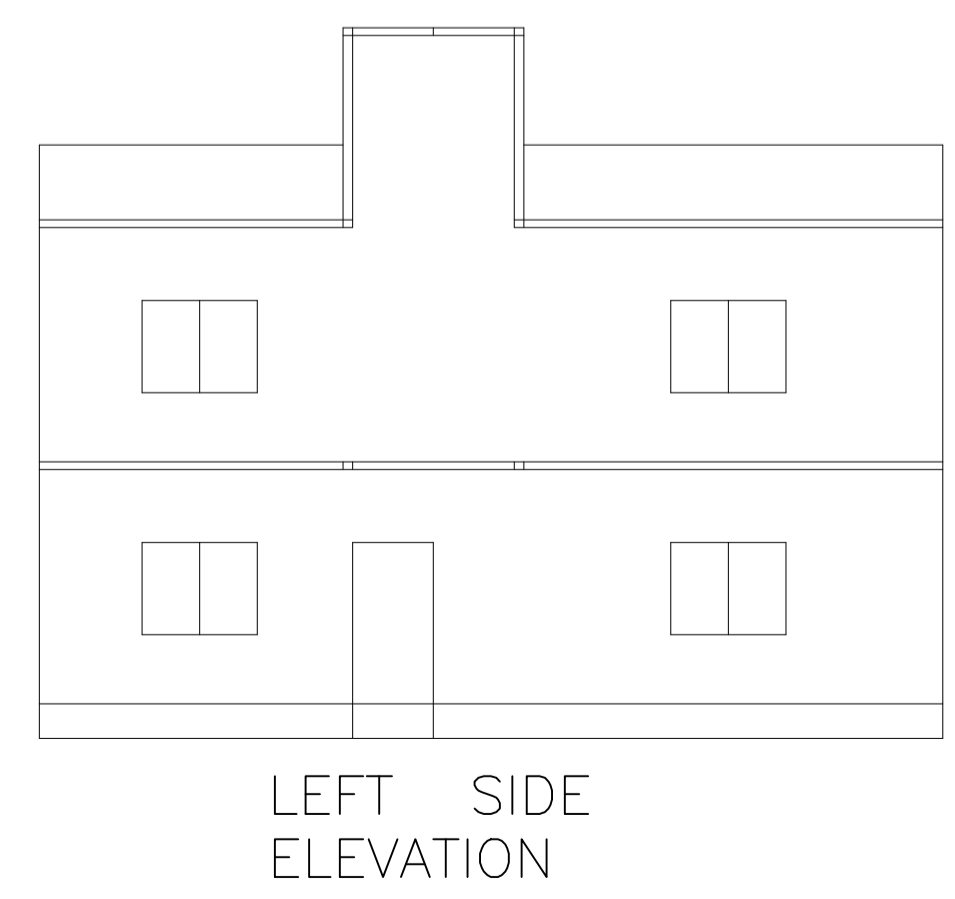

COLOR INDEX

PLOT BOUNDARY	Black
ABUTTING ROAD	Green
PROPOSED CONSTRUCTION	Red
COMMON PLOT	Yellow
ROAD WIDENING AREA	Blue
EXISTING (To be retained)	Light Blue
EXISTING (To be demolished)	Light Yellow

FAR & Tenement Details (Table 4c-1)

Building	No. of Same Bldg	Total Built Up Area (Sq.mt.)	Proposed FAR Area (Sq.mt.) Resi.	Total FAR Area (Sq.mt.)	Total Consumed Additional FAR Area (Sq.mt.)	Tnmt (No.)
A (A)	1	318.66	318.66	318.66	318.66	01
Grand Total :	1	318.66	318.66	318.66	318.66	01

Building :A (A)

Floor Name	Total Built Up Area (Sq.mt.)	Proposed FAR Area (Sq.mt.) Resi.	Total FAR Area (Sq.mt.)	Total Consumed Additional FAR Area (Sq.mt.)	Tnmt (No.)
Ground Floor	159.33	159.33	159.33	159.33	01
First Floor	159.33	159.33	159.33	159.33	00
Terrace Floor	0.00	0.00	0.00	0.00	00
Total :	318.66	318.66	318.66	318.66	01
Total Number of Same Buildings :	1				
Total :	318.66	318.66	318.66	318.66	01

Proposal Basic Information

Proposal File No.	DMC/BP/0274/W23/2020
Owner Name	SMT. REKHA KUMARI And SRI RANDHIR KUMAR
Khata No	05(NEW:235)
Plot No	556,555(NEW:1297)
Village Name	Saraidhela
Use	Residential
SubUse	Bungalow/ Dwelling / Non Apartment

Building USE/SUBUSE Details

Building Name	Building Use	Building SubUse	Building Structure
A (A)	Residential	Residential Bldg/Apartment	Non-Highrise

Buildingwise Floor FAR Details

Floor Name	Building Name A (A)		Total	
	Proposed Built Up Area (Sq.mt.)	Proposed FAR Area (Sq.mt.)	Total Proposed Built Up Area (Sq.mt.)	Total FAR Area (Sq.mt.)
Ground Floor	159.33	159.33	159.33	159.33
First Floor	159.33	159.33	159.33	159.33
Terrace Floor	0.00	0.00	0.00	0.00
Total :	318.66	318.66	318.66	318.66

SCHEDULE OF DOOR:

BUILDING NAME	NAME	LENGTH	HEIGHT	NOS
A (A)	d	0.90	2.10	18

SCHEDULE OF WINDOW/VENTILATION:

BUILDING NAME	NAME	LENGTH	HEIGHT	NOS
A (A)	w	1.19	1.20	01
A (A)	w	1.41	1.20	03
A (A)	w	1.80	1.20	25
A (A)	w	2.31	1.20	01
A (A)	w	2.46	1.20	01

UnitBUA Table for Building :A (A)

FLOOR	Name	UnitBUA Type	UnitBUA Area	Carpet Area	No. of Rooms	No. of Tenement
GROUND FLOOR PLAN	SPLIT 1	FLAT	318.66	318.57	12	1
FIRST FLOOR PLAN	SPLIT 1	FLAT	0.00	0.00	9	0
Total:	-	-	318.66	318.57	21	1

AREA STATEMENT	VERSION NO.: 1.0.51	SQ.MT.
DHANBAD MUNICIPAL CORPORATION	VERSION DATE: 16/10/2020	
PROJECT DETAIL:		
Region: JHARKHAND URBAN LOCAL BODIES	Plot Use: Residential	
District: DHANBAD	Plot SubUse: Bungalow/ Dwelling / Non Apartment	
Authority: DHANBAD MUNICIPAL CORPORATION	PlotNearby/ReligiousStructure: NA	
Inward_No: DMC/BP/0274/W23/2020	Plot/SubPlot No: 556,555(NEW:1297)	
Application Type: General Proposal	North: Plot No. - LOT NO. 51	
Project Type: Building Permission	South: Road Width - 6.0	
Nature of Development: New	East: Road Width - 6.0	
Location of Development Area: Old Area	West: Plot No. - LOT NO. 47	
AREA DETAILS:		
AREA OF PLOT (Minimum)	(A)	266.49
NET AREA OF PLOT(Gross Plot Area - Deduction from Gross Plot area)	(A-Deductions)	266.49
Deduction for Balance Plot Area(from Gross Plot Area)		
Common Plot		37.25
Total		37.25
BALANCE AREA OF PLOT(Net Plot Area - Recreational/Amenity space)	(A-Deductions)	229.24
PLOT AREA FOR COVERAGE(Net Plot Area)	(A-Deductions)	266.49
Plot Area for FAR (Net Plot Area + Road/Widening Area)	(A-Deductions)	266.49
COVERAGE CHECK		
Permissible Coverage area (60.00 %)		159.89
Proposed Coverage Area (59.79 %)		159.33
Total Prop. Coverage Area (59.79 %)		159.33
Balance coverage area (0.21 %)		0.56
FAR CHECK		
Perm. FAR Area (2.50)		666.22
Total Perm. FAR area		666.22
Residential FAR		318.66
Proposed FAR Area		318.66
Total Proposed FAR Area		318.66
Consumed FAR (Factor)		1.20
Balance FAR Area		347.56
BUILT UP AREA CHECK		
Total Proposed BuiltUp Area		318.66
ARCHITECT (Regd)	PARTHA - PAL	
ENGINEER (Regd)		
SUPERVISOR (Regd)		
OWNER (Regd)	SMT. REKHA KUMARI And SRI RANDHIR KUMAR	
DEVELOPMENT AUTHORITY LOCAL BODY		

LTP NAME AND SIGNATURE	STRUCTURAL ENG'S NAME AND SIGNATURE	BUILDER NAME AND SIGNATURE	DIGITAL SIGNATURE
PARTHA - PAL DMC/ENG/0021/2016			

Proposal Basic Information

Proposal File No.	DMC/BPI0274/W23/2020
Owner Name	SMT. REKHA KUMARI And SRI RANDHIR KUMAR
Khata No	05(NEW.235)
Plot No	556,555(NEW.1297)
Village Name	Saraidhela
Use	Residential
SubUse	Bungalow/ Dwelling / Non Apartment

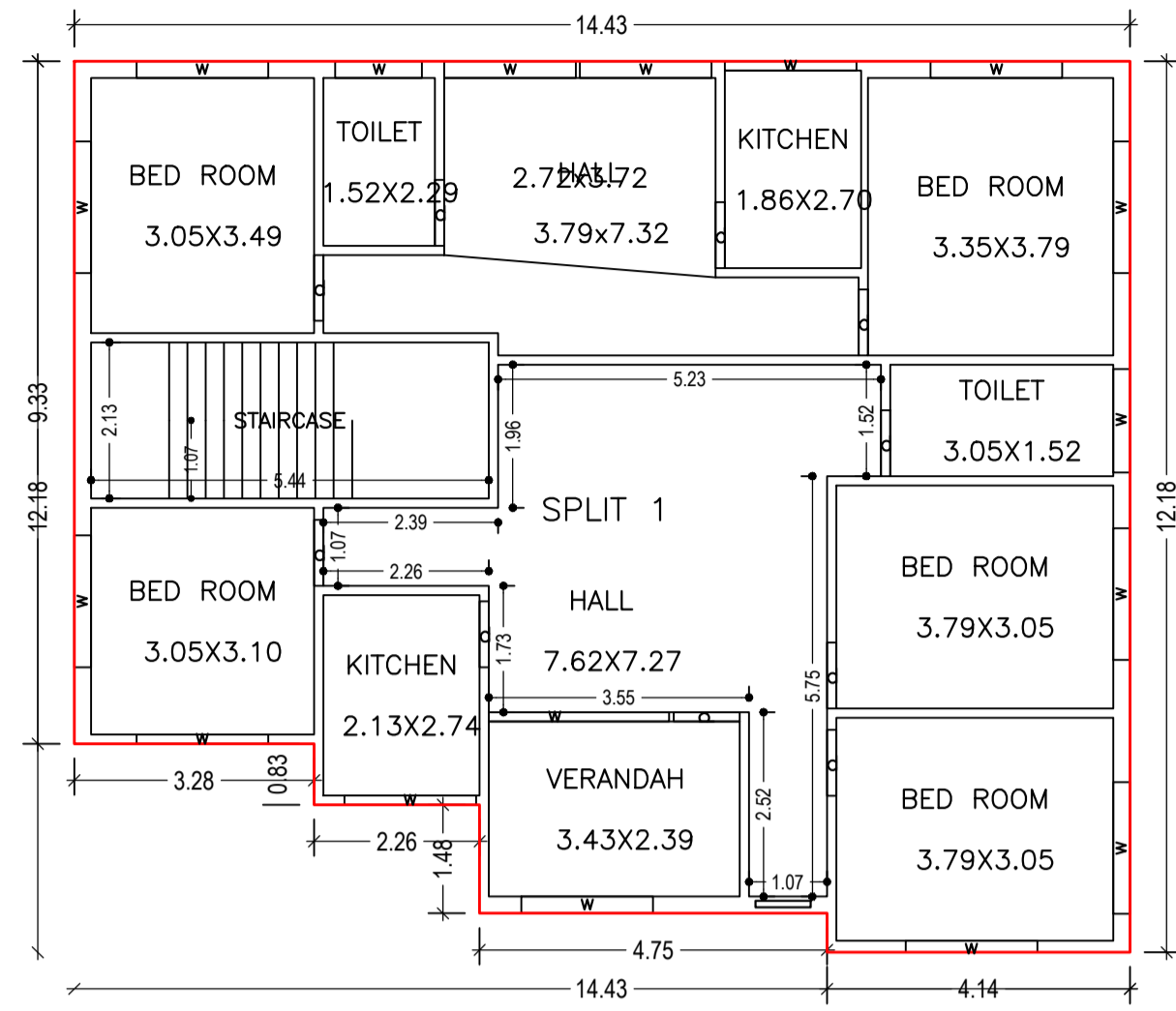

GROUND FLOOR PLAN
(Proposed)
(SCALE 1:100)

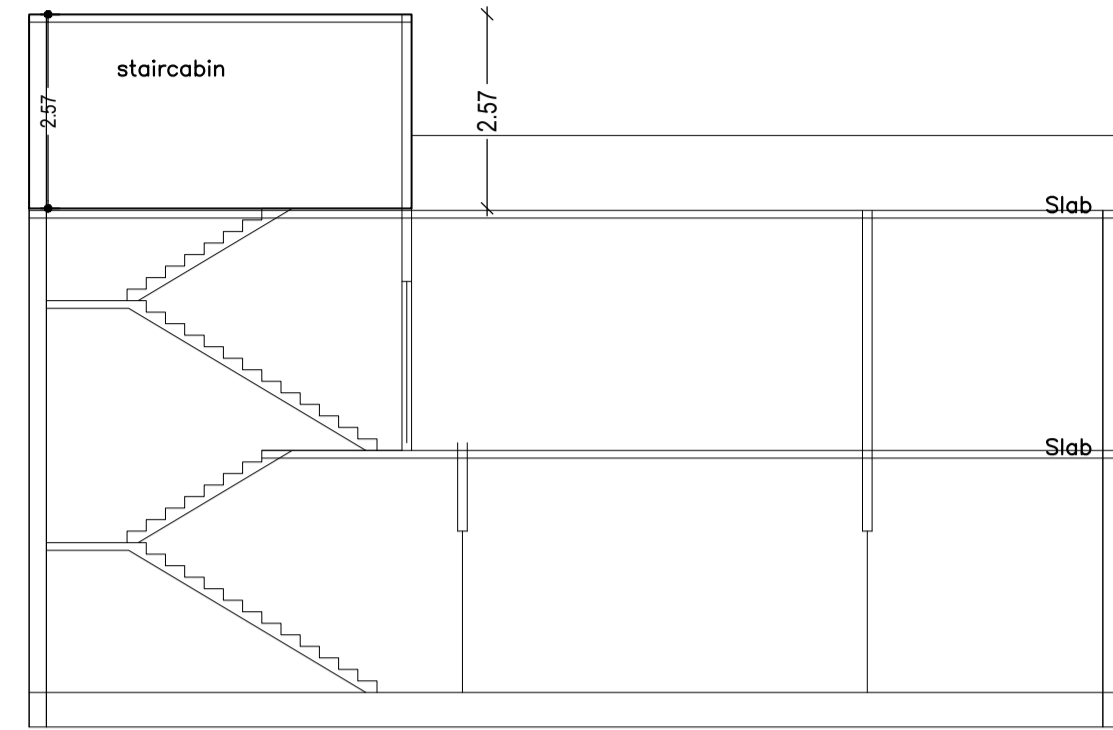

SECTION ON X-X

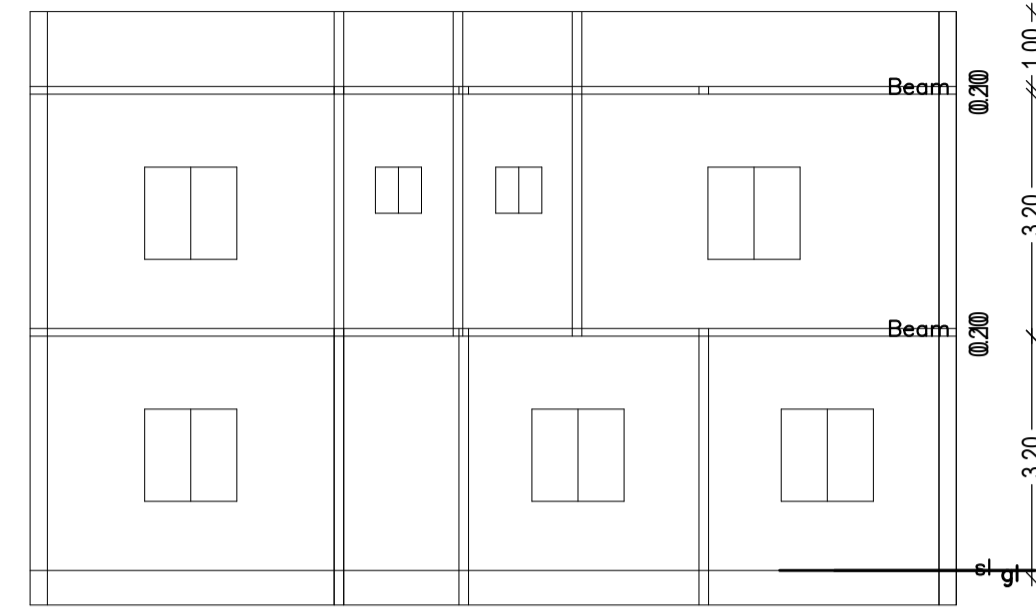

SECTION AT Y-Y

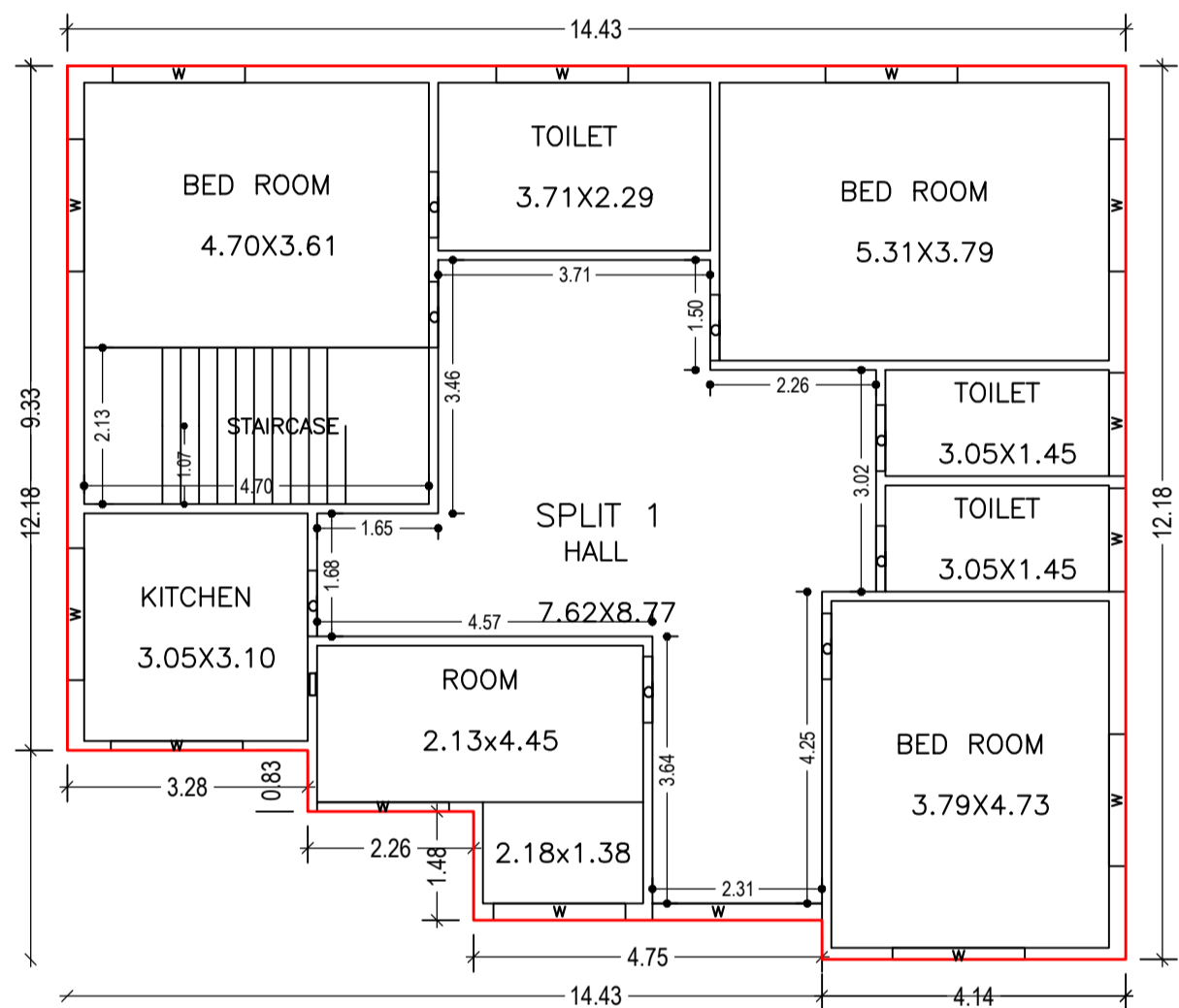
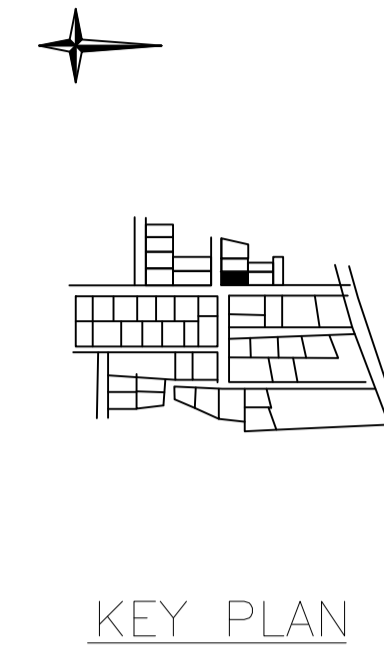

FIRST FLOOR PLAN
(Proposed)
(SCALE 1:100)

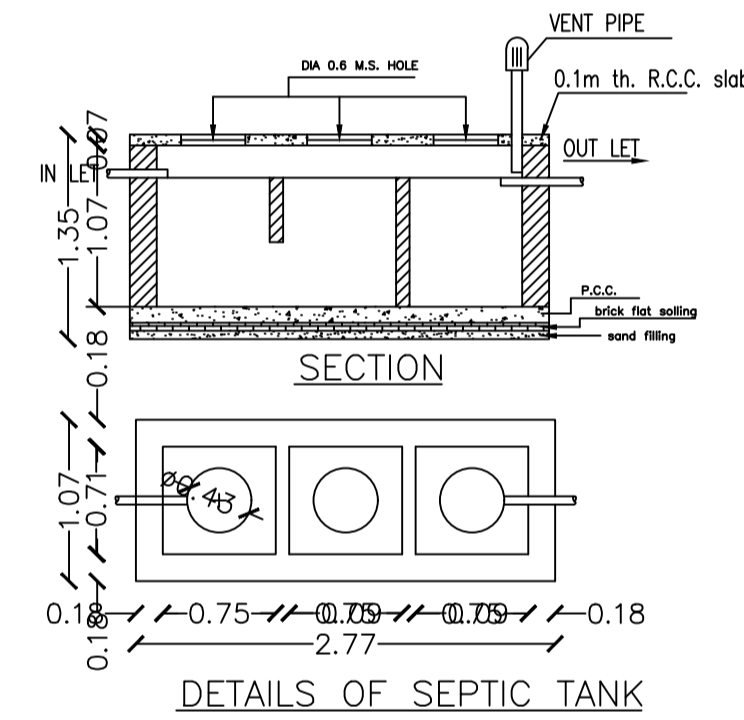

DETAILS OF SEPTIC TANK

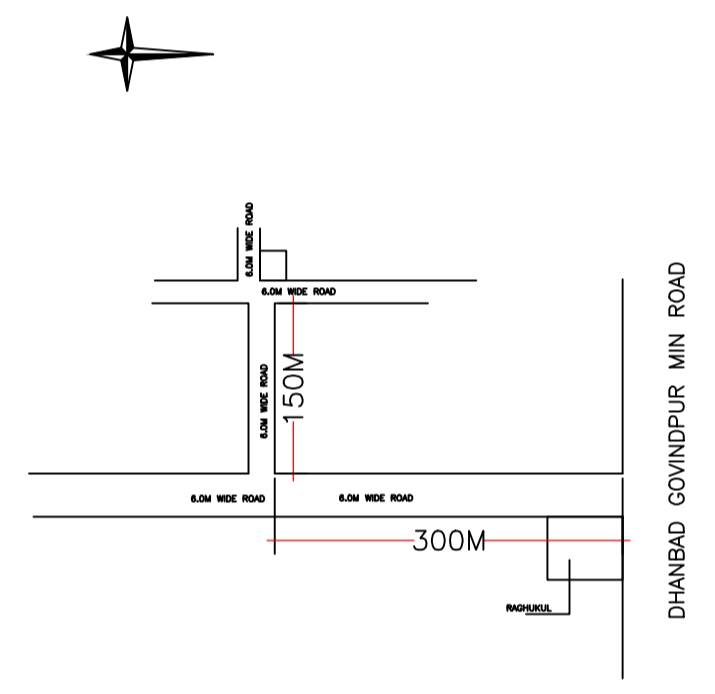

LOCATION

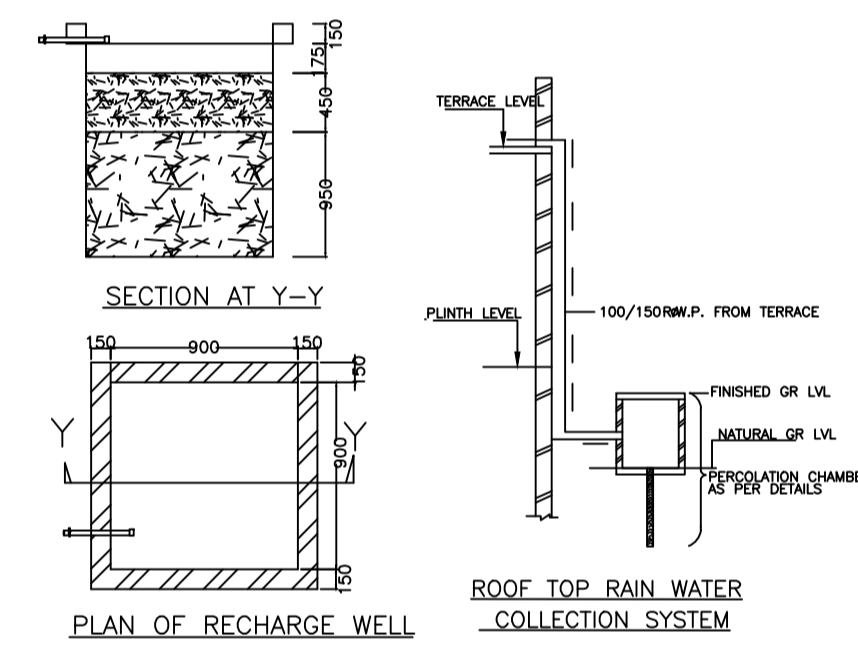

WATER HARVESTING

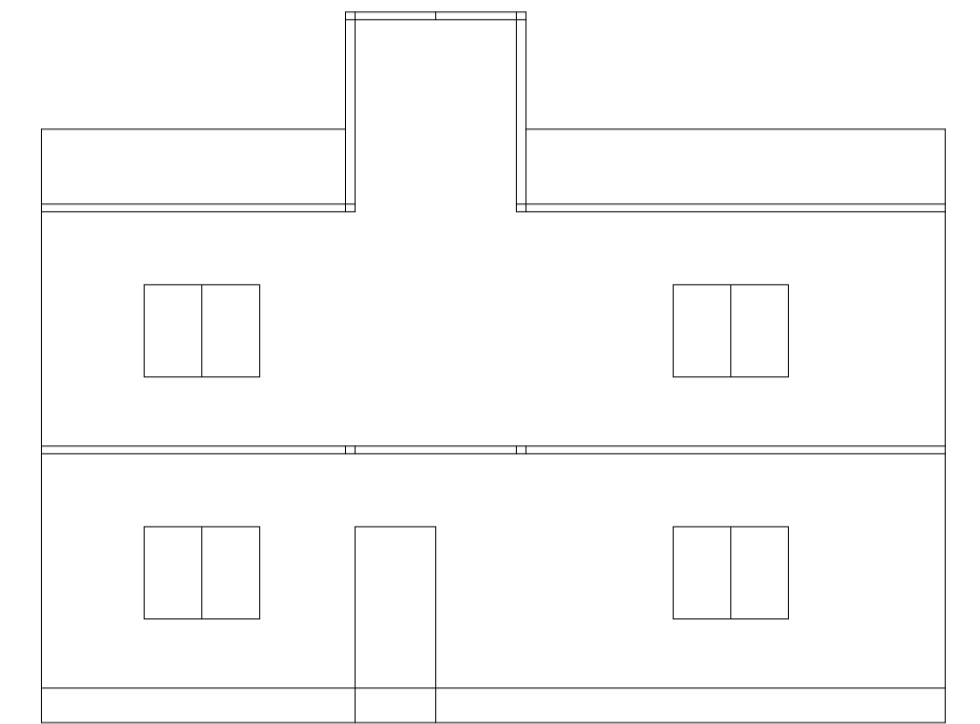

LEFT SIDE ELEVATION

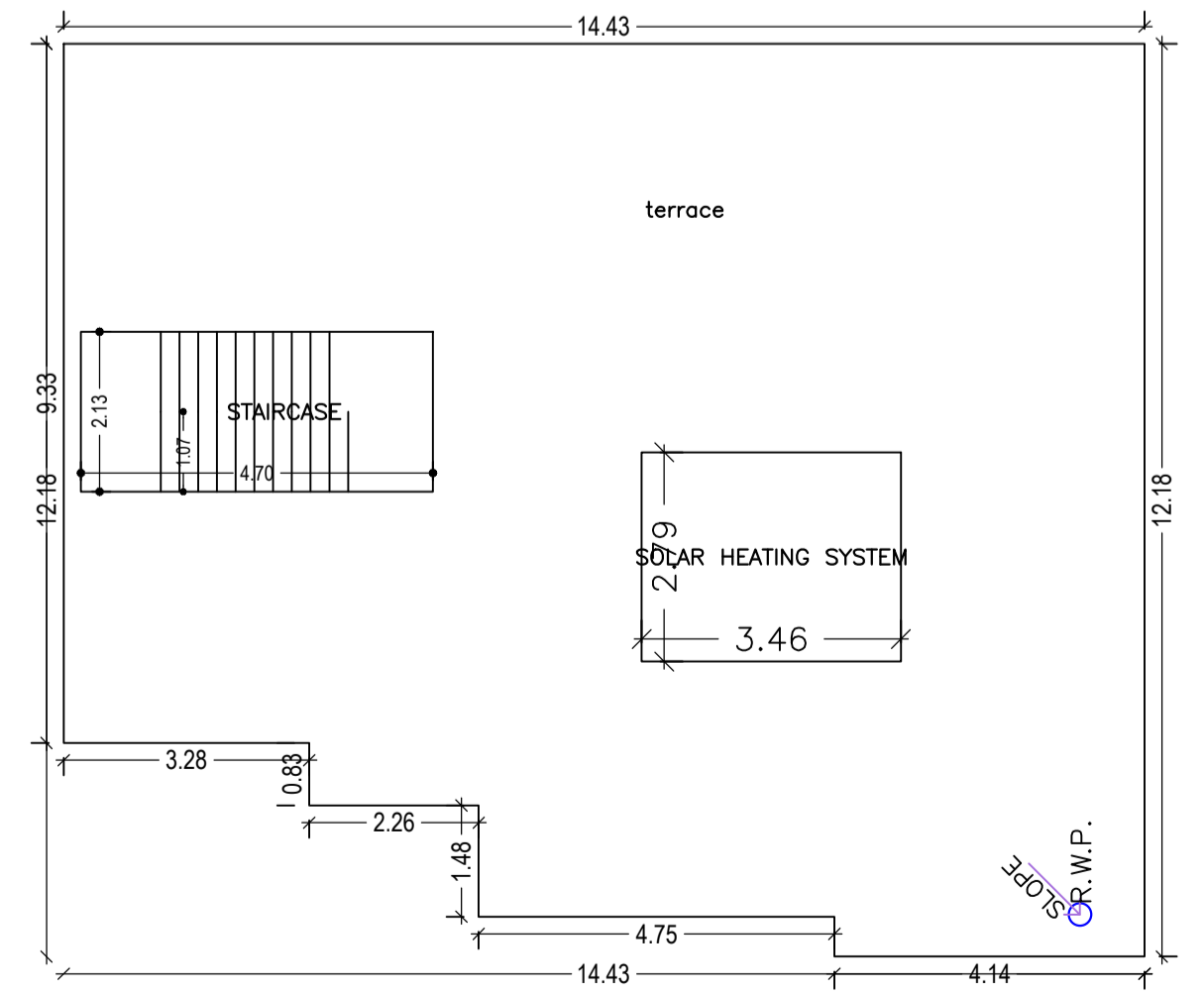

TERRACE FLOOR PLAN
(Proposed)
(SCALE 1:100)

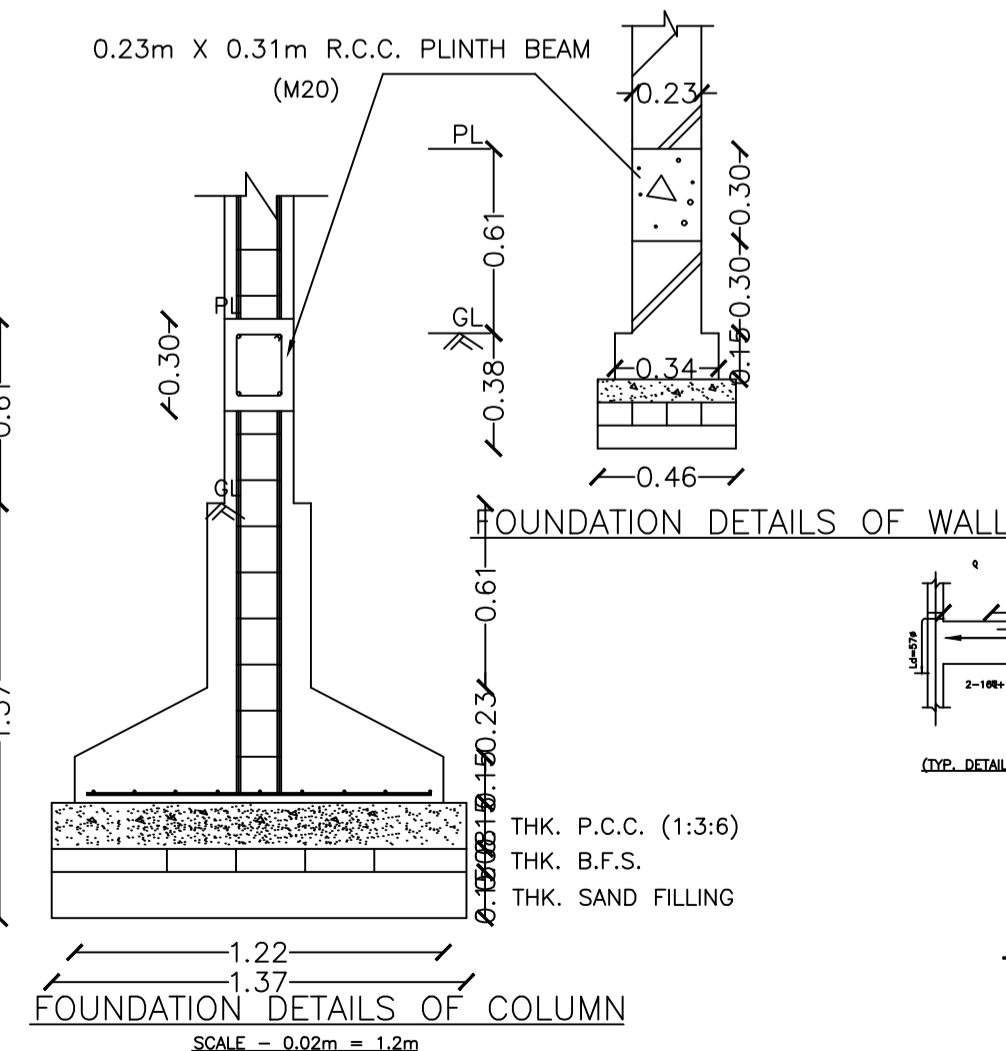

FOUNDATION DETAILS OF COLUMN
SCALE = 0.02m = 1cm

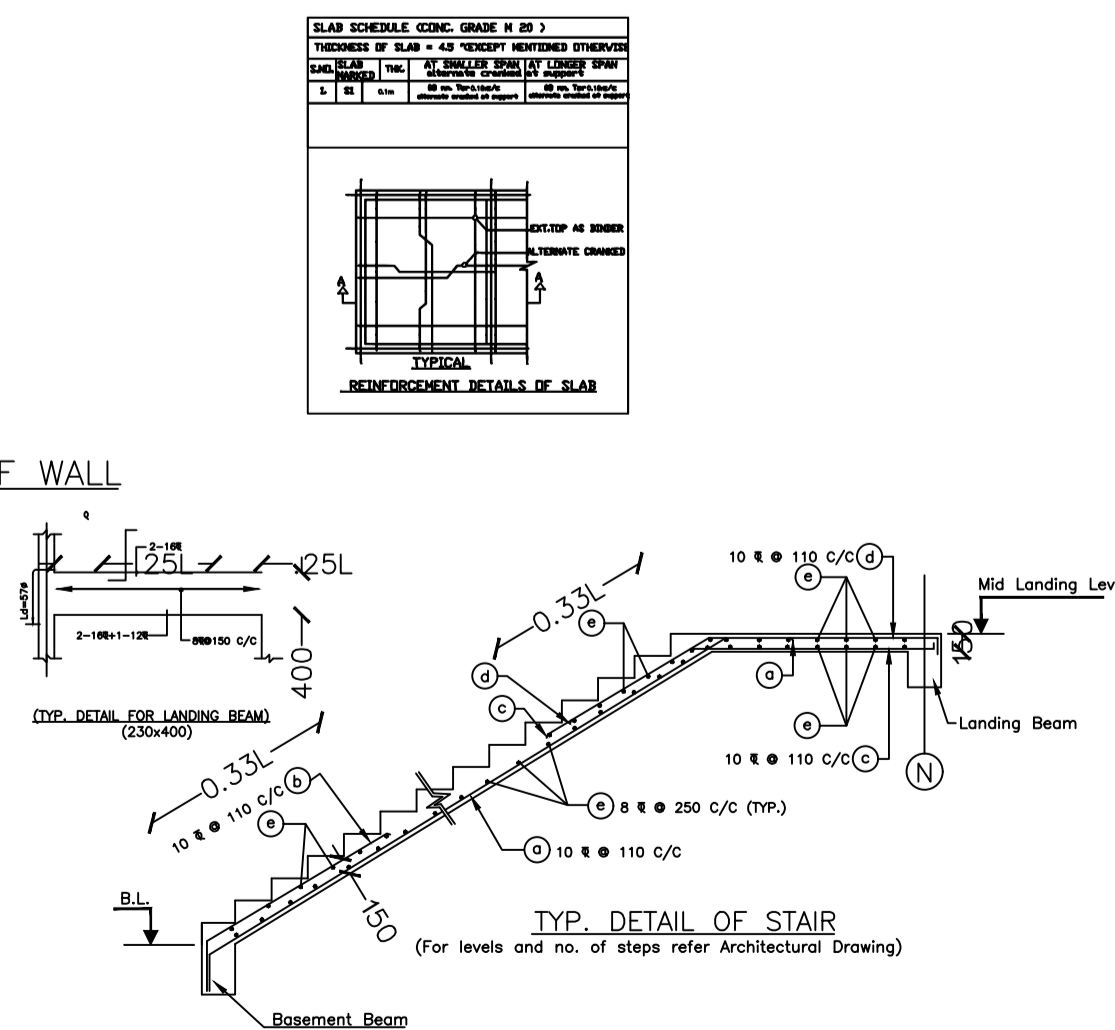

TYP. DETAIL OF STAIR
(For levels and no. of steps refer Architectural Drawing)

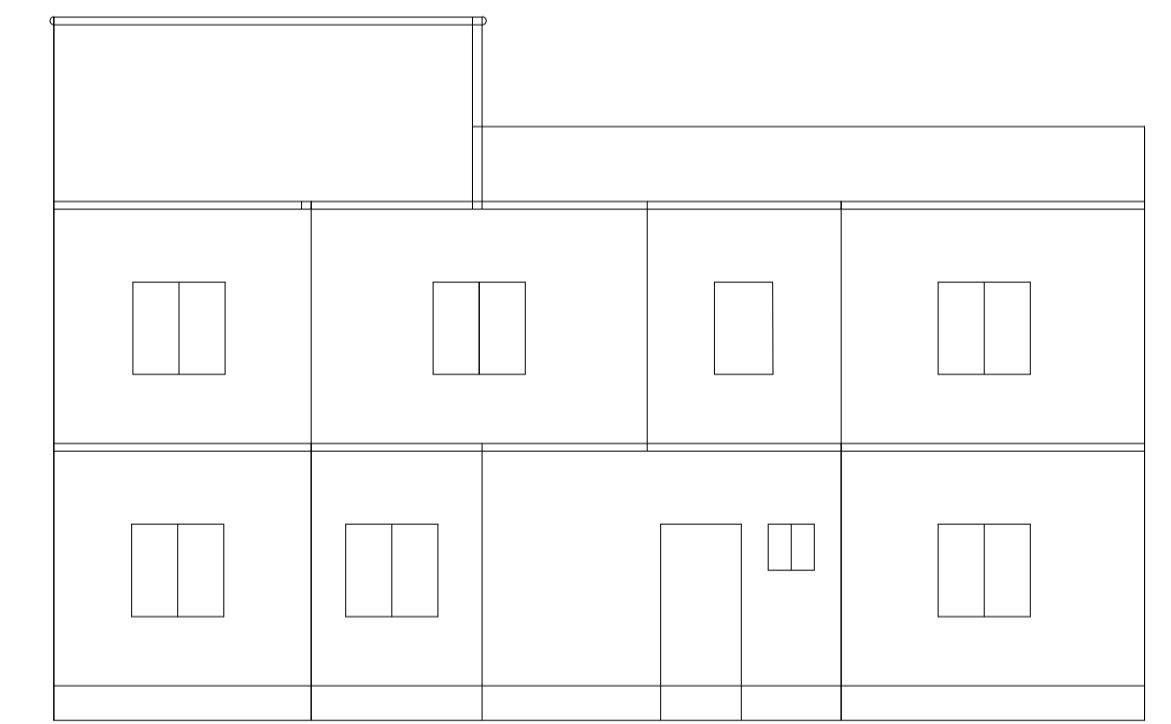

FRONT ELEVATION

LTP NAME AND SIGNATURE	STRUCTURAL ENG'S NAME AND SIGNATURE	BUILDER NAME AND SIGNATURE	DIGITAL SIGNATURE
PARTHA - PAL DMC/ENG/0021/2016			